

Your Owner's Manual

 Digital version available on the Internet

<http://go.skoda.eu/owners-manuals>



Tutorial videos

After reading in the following reference or the QR code, the website with the vehicle offer is displayed. By selecting the desired vehicle, the website with video instructions for selected vehicle functions is displayed.

 <http://go.skoda.eu/video-manuals>



ŠKODA KAROQ 11.2020
Angličtina/English
V1, R1, RoW, en_GB



57A012720AH

OWNER'S MANUAL

ŠKODA KAROQ



ŠKODA
SIMPLY CLEVER



Documentation of vehicle delivery

Vehicle Identification Number (VIN)

--	--	--	--	--	--	--	--	--	--	--	--	--	--	--	--	--	--	--	--

Date of vehicle delivery _____ / _____ / _____

ŠKODA Partner
Stamp and signature of the vendor

I confirm that I have taken delivery of the vehicle in good condition, have received information on how to operate it correctly, and have had the terms of the warranty explained to me.
Signature of the customer

Does the vehicle have an extended warranty?

YES

NO

Limitations of the ŠKODA extended warranty^{a)}

Years: _____

or

km: _____

or

Miles: _____

^{a)} Depending on which comes first.



Reprinting, reproduction or translation, either in whole or in part, is not permitted without the written consent of ŠKODA AUTO a.s..

ŠKODA AUTO a.s. expressly reserves all rights relating to copyright laws.

Subject to change.

Issued by: ŠKODA AUTO a.s.

© ŠKODA AUTO a.s. 2020

Vehicle owner

1. Vehicle owner

This vehicle with the official registration number

belongs to (Title, Name / Company)

Address:

Telephone:

ŠKODA Partner

Service consultant:

Telephone:

2. Vehicle owner

This vehicle with the official registration number

belongs to (Title, Name / Company)

Address:

Telephone:

ŠKODA Partner

Service consultant:

Telephone:



57A012720AH

Table of Contents

1	Vehicle owner	30	Sliding/tilting roof
5	About the Owner's Manual	31	Sunblind - with electrical operation
6	About the Owner's Manual	31	Sun visors
6	Tutorial videos	31	Boot lid - with manual operation
7	Explanations	31	Boot lid - with electrical control
7	Digital Instructions in Vehicle Infotainment	32	Electrically operated contactless boot lid
7	Application Quick Start Guide	33	Unlocking the boot lid
8	Vehicle overviews	34	Seats, steering wheel and mirror
8	Front vehicle area	34	Front seat - with manual operation
10	Rear vehicle area	34	Front seat - with electrical operation
11	Driver's seat	34	Memory function of the seat
11	Centre console and passenger seat	35	Rear seats
12	Engine compartment	36	Folding the backrests forward from the luggage compartment
12	Warning lights	36	Park position of rear seat belts
12	Functionality	36	VarioFlex rear seats
12	Warning lights overview	39	Headrests
16	Correct and safe	39	Front armrest
16	Introductory notes for correct use	39	Rear armrest
16	New vehicle or new parts	39	Load-through device
16	Regular checks	40	Steering wheel
16	Improper vehicle adjustments	41	Interior rear-view mirror
16	Keep sensors and cameras functional	41	Wing mirror
17	Engine compartment	42	Restraint systems and airbags
17	Handling operating fluids	42	Seat belts
17	12 volt vehicle battery	44	Child seat
17	Use electrical sockets in the vehicle	45	Fasteners for child seats
17	Before your journey	47	Airbags
18	Sitting safely	48	Key switch for the front passenger airbag
18	Correct belt webbing arrangement	49	Lighting, windscreen wipers and washers
18	Correct steering wheel position	49	Exterior lighting
18	Securing children properly	52	COMING HOME, LEAVING HOME exterior lighting
19	Transporting objects safely	52	Light Assist high-beam assist system
19	Safe driving	52	Replace light bulbs
20	Stop the vehicle safely!	55	Interior lighting
20	Exiting the vehicle	56	Interior ambient light
20	Deviating weather conditions	56	Windscreen wipers and washers
20	Emergency call	58	Heating and air conditioning system
21	After an accident	58	Manual air conditioning
23	Keys, locks and alarm system	59	Climatronic automatic air conditioning system
23	Key	61	Auxiliary heating and ventilation
24	Memory function of the key	63	Heated windscreen
24	Central locking	63	Seat heating
26	Keyless locking (KESSY)	64	Heated steering wheel
27	Alarm system	64	Driver information system
28	Doors, windows and boot lid	64	Analogue instrument cluster
28	Doors	65	Digital instrument cluster
28	Child safety lock on the rear doors	67	Driving data
28	Window - with electrical operation	68	Speed limit warning
		68	Vehicle status
		68	Stopwatch in the instrument cluster
		69	Stopwatch in the Infotainment Information Sport
		69	Information Sport

69	Personalization	157	Online Services
70	Infotainment Swing	157	ŠKODA Connect
70	Infotainment overview	158	ŠKODA Connect application
70	System	158	User registration and activation of the ŠKODA Connect services
71	Screen	159	Setting personal data protection
72	Infotainment keyboard	161	User management
73	Control centre	163	User account
73	Radio	163	Personalisation
75	Media	163	Management of online services
78	Mobile device management	164	eSIM data connection
80	Telephone	165	Online System Update
81	SmartLink	166	Shop
84	Infotainment Bolero	166	Information call
84	Infotainment overview	167	Breakdown call
84	System	167	Service schedules
85	Screen	167	Vehicle status report
86	Infotainment keyboard	168	Remote access to the vehicle
87	Voice control	168	Starting and driving
88	Control centre	168	Starting with the key
89	Radio	169	Start at the push of a button
92	Media	169	Starting issues
96	Images	170	START STOP
97	Mobile device management	170	Manual gearbox
98	Telephone	171	Automatic gearbox
101	Wi-Fi	172	Vehicle driving mode
103	SmartLink	173	Economical driving style
106	Infotainment Amundsen	174	Towing a trailer
106	Infotainment overview	175	Towing eye and towing procedure
106	System	176	Brakes
107	Screen	177	Electric parking brake
108	Infotainment keyboard	178	Auto Hold automatic holding function
109	Voice control	179	Driver assist systems
110	Control Centre	179	Braking and stabilising systems
110	Radio	180	Front Assist
114	Media	181	Pedestrian detection system
118	Images	181	Speed limiter
119	Mobile device management	182	Cruise control system
120	Telephone	183	Adaptive Cruise Control (ACC)
123	Wi-Fi	185	Lane Assist
125	SmartLink	186	Travel Assist
127	Navigation	187	Lane change assist system Side Assist
132	Infotainment Columbus	188	Traffic sign recognition
132	Infotainment overview	189	Crew Protect Assist proactive occupant protection
132	System	189	Driver Alert fatigue detection assistant
133	Screen	189	Emergency situation assist systemEmergency Assist
134	Keypad	190	Hill descent assistant
135	Voice control	191	Park Assist systems
136	Control centre	191	Park Pilot parking aid
136	Radio	192	Rear view camera
140	Media	192	Area View environment overview
144	Images	194	Rear Traffic Alert
145	Mobile device management	195	Park steering assistant
146	Telephone	196	Trailer assist trailer manoeuvring aid
149	Wi-Fi		
151	SmartLink		
153	Navigation		

198 Engine, exhaust system and fuel

- 198 Bonnet
- 198 Engine oil
- 199 Coolant
- 200 Engine electronics
- 201 Particle filter
- 201 Exhaust control system
- 201 Fuel filter
- 201 Radiator blinds
- 201 Fuel filler flap
- 202 AdBlue
- 202 Petrol
- 204 Diesel

205 12 volt vehicle battery and fuses

- 205 12 volt vehicle battery
- 206 Using the jump-starting cable
- 207 Fuses
- 208 Fuses in the dash panel
- 209 Fuses in the engine compartment

210 Wheels

- 210 Tyres and rims
- 211 All-season or winter tires
- 212 Snow chains
- 212 Spare and emergency spare wheel
- 213 Changing the wheel and raising the vehicle
- 214 Breakdown kit
- 215 Tyre pressure
- 216 Tyre pressure monitor
- 216 Wheel bolt cover caps
- 216 Full wheel frame

217 Storage space and interior equipment

- 217 Equipment in the boot
- 217 Emergency equipment
- 218 Tool kit
- 218 Storage compartment for the reflective vest
- 218 Fasteners in the boot
- 219 Bag hooks in the boot
- 219 Cargo elements in the luggage compartment
- 219 Fastening nets
- 219 Sliding hooks
- 220 Net partition
- 220 Double-sided floor covering
- 220 Rigid boot cover
- 220 Roll-up luggage compartment cover
- 221 Variable loading floor in the boot
- 221 Through-loading bag
- 222 Interior equipment front
- 223 Interior equipment rear
- 223 Car park ticket holder
- 223 Rubber band in the door trim
- 224 Bottle tray in the storage compartment of the front door
- 224 Bottle tray in the storage compartment of the rear door
- 224 USB-connections
- 225 Hook on the centre body pillar

- 225 Glasses compartment
- 225 Pen holder
- 226 Storage compartment for cards, coins and SD card
- 226 Storage compartment for cards in the storage area on the driver's side
- 226 Storage compartment for an umbrella
- 226 Phonebox
- 227 Cup holder
- 227 Cup holder Easy Open
- 227 Waste container
- 227 Ashtray and cigarette lighter
- 228 Folding table
- 228 Multifunction holder
- 228 Tablet holder
- 229 12-Volt power socket
- 229 230-Volt power socket
- 230 230 volt socket and USB connections
- 230 Storage compartment with air outlet nozzle

230 Roof rack and hitch

- 230 Roof rack
- 230 Swivelling hitch

233 Maintaining and cleaning

- 233 Service events
- 233 Service work, adjustments and technical changes
- 234 Interior
- 235 Exterior
- 236 Ice scraper

237 Technical data and specifications

- 237 Requirements for the technical data
- 237 Vehicle identification data
- 237 Maximum permissible weights
- 238 Operating weight
- 238 Vehicle dimensions
- 239 Engine specifications
- 240 Accident data recorder (Event Data Recorder)
- 241 Personal data
- 241 Information about the radio systems in the vehicle
- 242 Rights arising from defective performance, ŠKODA warranties

244 Index

About the Owner's Manual

General points

This Owner's Manual applies to all **chassis variants** of the vehicle, including all **models** and **trim levels**.

All possible **trim levels** are described here without identifying them as special trims, model variants or market-dependent equipment. This means that **not all the trim components** described in this Owner's Manual are available in your vehicle.

The **illustrations** in these operating instructions are purely illustrative and are to be understood as general information. The illustrations may differ from your vehicle.

ŠKODA AUTO is constantly working on the further development of all vehicles. It is therefore possible for changes to be made at any time to the scope of delivery in terms of shape, equipment and technology. The information contained in this Owner's Manual corresponds to the information available at the time of going to press.

No legal claims can therefore be derived from the technical data, illustrations and information in this Owner's Manual.

Digital version of the Owner's Manual

Keeping environmental protection in mind, the printed Owner's Manual only contains the most important information regarding vehicle operation and vehicle maintenance.

The digital version of the Owner's Manual includes full information regarding vehicle operation.

The digital version is available at the following places:

- ▶ On the ŠKODA web pages
- ▶ In the mobile application MyŠKODA
- ▶ In infotainment Bolero, Amundsen, Columbus

<http://go.skoda.eu/owners-manuals>



Digital version of the Owner's Manual in Infotainment

Applies to Infotainment Bolero, Amundsen and Columbus.

The digital version of the Owner's Manual can be displayed in the Infotainment in the menu **MENU** >  as follows.

Tutorial videos

After reading in the following reference or the QR code, the website with the vehicle offer is displayed. By selecting the desired vehicle, the website with video instructions for selected vehicle functions is displayed.

<http://go.skoda.eu/video-manuals>



About the Owner's Manual

General points

This Owner's Manual applies to all **chassis variants** of the vehicle, including all **models** and **trim levels**.

All possible **trim levels** are described here without identifying them as special trims, model variants or market-dependent equipment. This means that **not all the trim components** described in this Owner's Manual are available in your vehicle.

The **illustrations** in these operating instructions are purely illustrative and are to be understood as general information. The illustrations may differ from your vehicle.

ŠKODA AUTO is constantly working on the further development of all vehicles. It is therefore possible for changes to be made at any time to the scope of delivery in terms of shape, equipment and technology. The information contained in this Owner's Manual corresponds to the information available at the time of going to press.

No legal claims can therefore be derived from the technical data, illustrations and information in this Owner's Manual.

Digital version of the Owner's Manual

Keeping environmental protection in mind, the printed Owner's Manual only contains the most important information regarding vehicle operation and vehicle maintenance.

The digital version of the Owner's Manual includes full information regarding vehicle operation.

The digital version is available at the following places:

- ▶ On the ŠKODA web pages
- ▶ In the mobile application MyŠKODA

 <http://go.skoda.eu/owners-manuals>



Tutorial videos

After reading in the following reference or the QR code, the website with the vehicle offer is displayed. By selecting the desired vehicle, the website with video instructions for selected vehicle functions is displayed.

 <http://go.skoda.eu/video-manuals>



Tutorial videos

Tutorial videos

After reading in the following reference or the QR code, the website with the vehicle offer is displayed. By selecting the desired vehicle, the website with video instructions for selected vehicle functions is displayed.

 <http://go.skoda.eu/video-manuals>



Explanations

Terms used

- “Specialist garage”** - A workshop that carries out specialist service tasks for ŠKODA vehicles. A specialist can be a ŠKODA Partner, a ŠKODA Service Partner, or an independent workshop.
- “ŠKODA Service Partner”** - A workshop that has been contractually authorised by ŠKODA AUTO or its distribution partner to perform service work on ŠKODA vehicles and to sell ŠKODA Genuine Parts.
- “ŠKODA Partner”** - A company that has been contractually authorised by ŠKODA AUTO or its distribution partner to sell new ŠKODA vehicles and, when applicable, to service them using ŠKODA Genuine Parts and sell ŠKODA Genuine Parts.

Text notes

- “Press”** - short press (e.g. a button) within 1 second
- “Hold”** - long press (e.g. a button) for more than 1 second

Direction indications

All direction indications, such as “left”, “right”, “front”, “rear”, relate to the forwards direction of travel of the vehicle.

⚠ DANGER

Texts with this symbol indicate dangerous situations which, if the safety instructions are not observed, will result in death or serious injury.

⚠ WARNING

Texts with this symbol indicate dangerous situations which, if the safety instructions are not observed, could result in death or serious injury.

⚠ CAUTION

Texts marked with this symbol indicate dangerous situations which, if the safety instructions are not observed, could result in minor or moderate injury.

ⓘ NOTICE

Texts with this symbol indicate situations which, if the corresponding instructions are not observed, will result in damage to the vehicle.

i Texts with this symbol contain additional information.

Digital Instructions in Vehicle Infotainment

Application Quick Start Guide

Interactive images

In the pictures with the outside of the vehicle and the inside of the vehicle, there are touch points. Tapping a touch point displays a menu with topics or a detailed image.

Symbols

Information about symbols that can be shown on the instrument cluster display. By tapping the symbol, a detailed description is displayed.

Topics

The instruction content is organized according to topics.



Top bar of the displayed topic

- A** Title of the topic
- B** Type of information displayed / display menu with information
- C** Text search

About the instructions

Language selection for instructions and updates.

Vehicle overviews

Front vehicle area

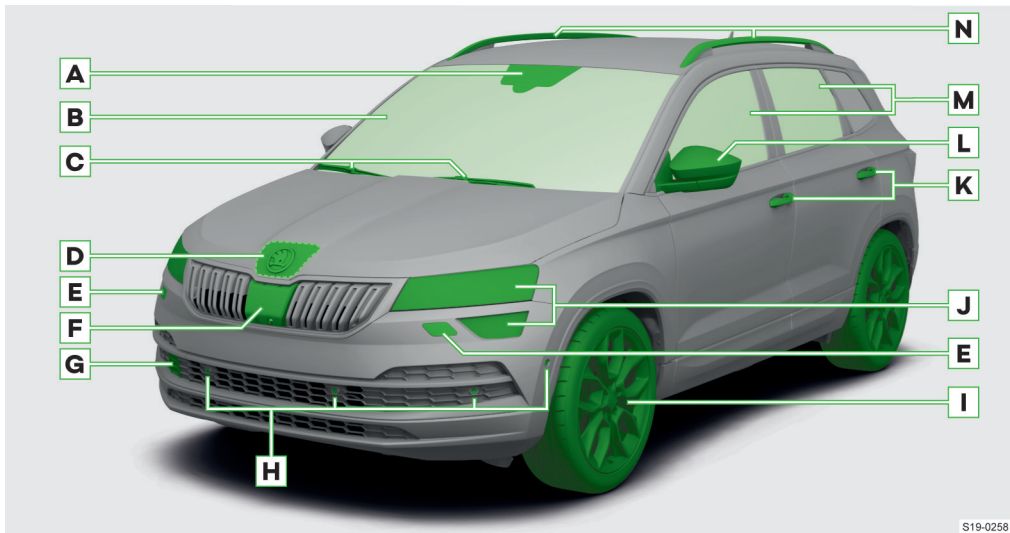

S19-0258

- A** Under the windscreen (depending on the vehicle equipment):
 - ▶ Camera for assist systems
 - ▶ Light sensor for automatic driving light circuit » [page 49](#)
 - ▶ Rain sensor for automatic wiping » [page 56](#)
- B** Windscreen - heating » [page 63](#)
- C** Windscreen wiper – operation » [page 56](#)
- D** Bonnet release lever (on the inside of the flap) » [page 198](#)
- E** Headlamp cleaning system » [page 56](#)
- F** Cover in the radiator grille (depending on the vehicle equipment):
 - ▶ Front radar sensor for assist systems
 - ▶ Camera for assist systems
- G** Cover for screw-in towing eye socket » [page 175](#)
- H** Ultrasonic sensors for assist systems
- I** Wheels:
 - ▶ Tyres and rims » [page 210](#)
 - ▶ Changing the wheel and raising the vehicle » [page 213](#)
 - ▶ Breakdown kit » [page 214](#).
 - ▶ Tyre pressure » [page 215](#)
 - ▶ Tyre pressure monitor » [page 216](#)
- J** Headlights (depending on vehicle equipment):
 - ▶ Operation » [page 50](#)
 - ▶ Light Assist high-beam assist system » [page 52](#)
 - ▶ Replace light bulbs » [page 52](#)
- K** Door handles (depending on vehicle equipment):
 - ▶ Open door » [page 28](#)
 - ▶ Keyless locking (KESSY) » [page 26](#).

L Exterior mirror (depending on vehicle equipment):

- ▶ Operation » [page 41](#)
- ▶ Camera for assist systems

M Side door windows - operation » [page 29](#).

N Roof rack » [page 230](#)

Functionality of the sensors and cameras

- › Keep the sensors and cameras for the assist systems clean » [page 16](#).

Rear vehicle area

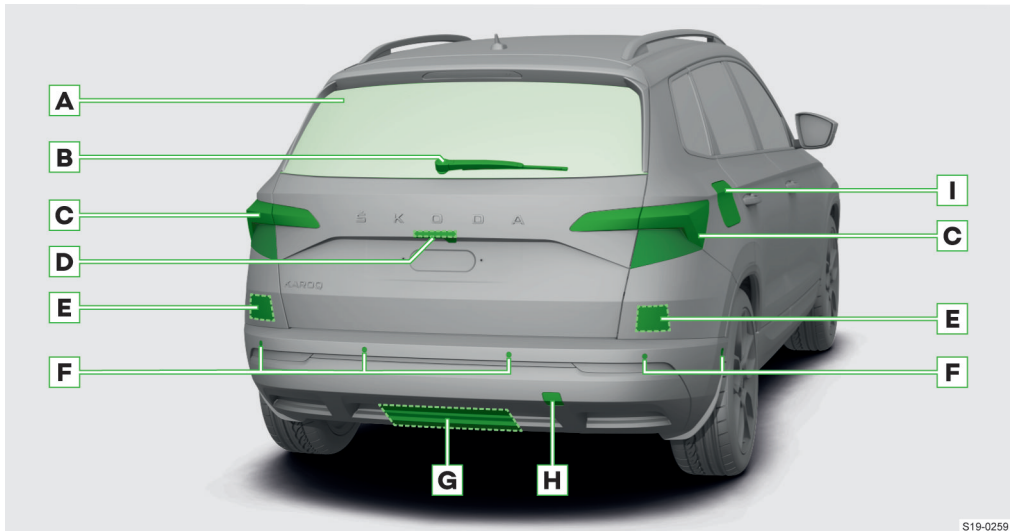

S19-0259

- A** Rear window - heating » page 63
- B** Rear window wiper and washer - Operation » page 56
- C** Tail lights:
 - ▶ Operation » page 50
 - ▶ Replace light bulbs » page 52
- D** Boot lid handle (depending on the vehicle equipment).
 - ▶ Manually operated boot lid » page 31
 - ▶ Electrically operated boot lid » page 31
 - ▶ Camera for assist systems
- E** Radar sensors for assist systems (in the bumper)
- F** Ultrasonic sensors for assist systems
- G** Depending upon vehicle equipment:
 - ▶ Swivelling tow coupling » page 230
 - ▶ Electrically operated contactless boot lid » page 33
- H** Cover for screw-in towing eye socket » page 175
- I** Fuel tank lid:
 - ▶ Opening » page 201
 - ▶ Sticker with tyre pressure values » page 215
 - ▶ Sticker with prescribed fuel
 - ▶ Ice scraper
 - ▶ Filler neck of the AdBlue* tank » page 202

Functionality of the sensors and cameras

- › Keep the sensors and cameras for the assist systems clean » page 16.

Driver's seat

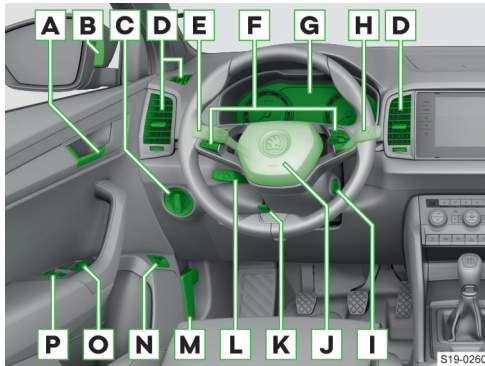

- A** Door opening lever » page 28
- B** Side Assist lane change assist system indicator light » page 187
- C** Light switch » page 50
- D** Air outlet nozzle
- E** Control lever (depending on vehicle equipment):
 - ▶ Turn signal and main beam » page 50
 - ▶ Speed regulating system » page 182
 - ▶ Speed limiter » page 181
 - ▶ High beam assist system » page 52
- F** Buttons/dials on the multifunction steering wheel » page 40
- G** Depending upon vehicle equipment:
 - ▶ Analogue instrument cluster » page 64
 - ▶ Digital instrument cluster » page 65
- H** Operating lever:
 - ▶ Windscreen wipers and washers » page 56
- I** Depending upon vehicle equipment:
 - ▶ Ignition lock » page 168
 - ▶ Starter button » page 169
- J** Steering wheel with horn/with driver's front air-bag » page 47
- K** Safety lever for steering wheel adjustment » page 40
- L** Operation of the automatic distance control » page 184
- M** Bonnet release lever » page 198
- N** Button for the electric boot lid » page 31
- O** Exterior mirror operation » page 41
- P** Window operation » page 29.

Centre console and passenger seat

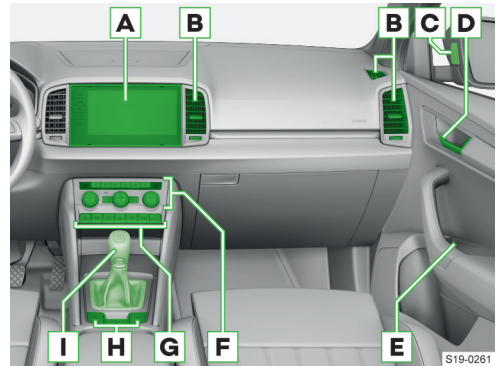

- A** Infotainment (depending on vehicle equipment):
 - ▶ Columbus » page 132
 - ▶ Amundsen » page 106
 - ▶ Bolero » page 84
 - ▶ Swing » page 70
- B** Air outlet nozzle
- C** Side Assist lane change assist system indicator light » page 187
- D** Door opening lever » page 28
- E** Window operation in the passenger door » page 29
- F** Operation (depending on vehicle equipment):
 - ▶ Climatronic » page 59
 - ▶ Manual air conditioning » page 58.
- G** Buttons and indicator lights (depending on the vehicle equipment):
 - Buttons:
 - ▶ START-STOP » page 170
 - ▶ Park Assist » page 195
 - ▶ Park Pilot » page 191
 - ▶ Hazard warning light system » page 50
 - ▶ Central locking » page 25
 - Indicator lights:
 - ▶ Front passenger airbag ON / OFF » page 48
- H** Keys (depending on vehicle equipment):
 - ▶ Driving mode selection » page 172
 - ▶ Auto Hold » page 178
 - ▶ Parking brake » page 177
 - ▶ Stabilisation Control ESC / Traction Control ASR » page 179
 - ▶ Offroad mode » page 172
- I** Depending upon vehicle equipment:
 - ▶ Gearshift lever (manual gearbox) » page 170
 - ▶ Selector lever (automatic gearbox) » page 171

Engine compartment

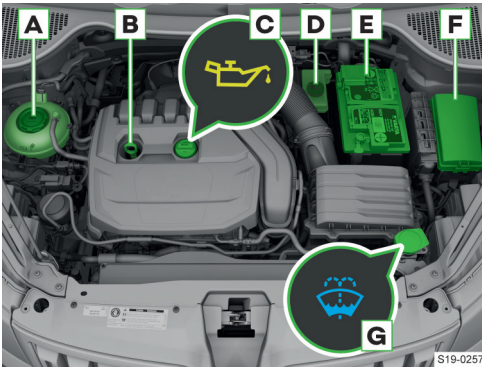

- A** Coolant expansion reservoir » page 199
- B** Engine oil dipstick » page 198
- C** Engine oil filler opening » page 198
- D** Brake fluid reservoir » page 176
- E** 12 volt vehicle battery » page 205
- F** Fuse box » page 209
- G** Windscreen washer fluid reservoir » page 57

Warning lights

Functionality

⚠ WARNING

Disregarding the lighting up of the warning lights and the associated messages on the display of the instrument cluster can lead to accidents, serious injuries or damage to the vehicle.

The warning lights in the instrument cluster indicate certain functions or faults.

The illumination of some of the indicator lights may be accompanied by acoustic signals and messages in the instrument cluster display.

Colour display of the indicator lights

Depending on the vehicle equipment, the colour scheme of the indicator lights may vary. The coolant indicator light can, e.g. be shown in colour as follows:

⬇ - coloured display

⬆ - black and white display

Additional indicator lights

The additional indicator light will also light up in the display along with some of the indicator lights:

⚠ - Hazard















⚠ - Warning















Warning lights overview

After switching on the ignition, some indicator lights light up briefly as a function test of the vehicle systems. If the tested systems are in order, the respective indicator lights go out a few seconds after the ignition is switched on or after the engine has been started.



















For further details » page 12, *Functionality*.























Symbol	Meaning
	Indicates a warning together with another warning light » page 12.
	Unfastened seat belts at the front and rear » page 43.
	12-volt vehicle battery is not charging » page 206.
	Along with ⬇ - Engine fault » page 200, » page 206.
	Engine oil pressure too low » page 199.
	Engine oil level too low » page 199.





















Symbol	Meaning
	Coolant level is too low » page 200.
	Coolant temperature too high » page 200.
	Brake fluid level is too low » page 177.
	Together with  - Brake system and ABS faulty » page 180.
	Parking on a slope with too much inclination » page 178.
	Parking brake on » page 177.
	illuminates - Power assisted steering faulty » page 40.
	Flashing - Steering lock faulty » page 41.
	Automatic gearbox impaired » page 172.
	Automatic gearbox overheated » page 172.
	Take control immediately » page 186.
	AdBlue® level too low » page 202.
	AdBlue® system impaired » page 202.
	Warning if there is a risk of a collision » page 180.
	ACC does not decelerate sufficiently » page 183, » page 183.
	Indicates a warning along with another warning light » page 12.
	The fuel supply has reached the reserve area. » page 204, » page 205.
	Windscreen washer fluid level too low » page 57.
	Bulb faulty » page 51.
	Rear fog light switched on » page 50.
	Engine oil level too high or engine oil level sensor impaired » page 199.
	Clogged particle filter » page 201.
	Parking brake error » page 177.
	ABS faulty » page 180.

Symbol	Meaning
	Worn brake pads » page 177.
	Automatic gearbox overheated » page 172.
	Automatic gearbox impaired » page 172.
	Water in the diesel fuel filter » page 201.
	AdBlue® system impaired » page 202.
	AdBlue® level too low » page 202.
	Tyre pressure control system faulty » page 216.
	Tyre pressure change » page 211, » page 216.
	illuminates - Power assisted steering faulty » page 40.
	Flashing - Steering lock not unlocked » page 41.
	Flashing - Steering lock faulty » page 41.
	KESY - starting problem » page 169.
	KESY - no key found » page 27.
	Adaptive suspension faulty » page 173.
EPC	Petrol engine control faulty » page 200.
	Emission control system faulty » page 201.
	illuminates , if relevant, does not illuminate after switching on the ignition - Diesel preheating system faulty » page 200.
	Flashing - Diesel engine control faulty » page 200.
	Front passenger airbag switched on » page 49.
ON	flashes together with OFF - Key switch for airbag deactivation is faulty » page 49.
OFF	Front passenger airbag switched off » page 49.

14 Warning lights › Warning lights overview

Symbol	Meaning
	Airbag system faulty » page 48. Crew Protect Assist faulty » page 189. Illuminates for 4 seconds and then flashes - Airbag or belt tensioner deactivated with diagnostic device » page 48.
	Ball rod not locked » page 231.
	ESC Offroad is activated » page 173.
	ESC Sports enabled » page 179.
	ASR deactivated » page 179.
	Illuminates - ESC or ASR faulty » page 180.
	Flashing - ESC or ASR is engaged » page 179.
	Front Assist deactivated » page 180, » page 180.
	ACC not available » page 185.
	Lane Assist intervenes » page 185.
	Lane Assist intervenes » page 185.
	Turn signal light, left » page 50, » page 51.
	Rear seat belt fastened » page 43.
	Turn signal light, right » page 50, » page 51.
	Trailer turn signal light » page 51.
	Front fog lights switched on » page 50.
	The selector lever is locked » page 171.
	Vehicle is secured by Auto Hold » page 178.
	Lane Assist is activated and ready to intervene » page 185.
	Lane Assist is activated and ready to intervene » page 185.
	ACC controls the driving speed » page 183.
	ACC controls the driving speed » page 183, » page 183.

Symbol	Meaning
	The cruise control system controls the driving speed » page 182.
	Travel Assist activated » page 186.
	Travel Assist activated - the cruise control is active » page 186.
	Travel Assist activated - the lane guidance is active » page 186.
	Low outside temperature » page 65.
	High beam or flasher activated » page 50.
	Unoccupied rear seat » page 43.
	Rear seat belt not fastened » page 43.
	A rear seat belt is not fastened » page 43.
	A rear seat belt is fastened » page 43.
	A rear seat belt is fastened » page 43.
	High beam Assist System switched on » page 52.
	No light is switched on » page 50.
	AdBlue® level too low » page 202.
	AdBlue® system impaired. » page 202.
	Take control » page 186.
	Adaptive suspension faulty » page 173.
	Service event » page 233.
	Engine was switched off automatically by START-STOP » page 170.
	Engine was not automatically switched off via START-STOP » page 170.
	Speed limiter faulty » page 182.
	Speed limiter activated » page 181.
	ACC » page 185.

Symbol	Meaning
	ACC activated » page 183 , » page 183 .
	ACC controls the driving speed according to the approaching roundabout » page 183 .
	ACC controls the driving speed according to the approaching junction » page 183 .
	ACC controls the driving speed according to the road » page 183 .
	ACC controls the driving speed according to the permissible speed » page 183 .
	Cruise control system faulty » page 183 .
	Cruise control activated » page 182 .
	The Hill Descent Assist System is activated » page 190 .
	Hill Descent Assist System intervenes » page 190 .
	Front Assist deactivated » page 180 , » page 180 .
	Front Assist is started » page 180 .
	Safety distance too small » page 180 .
	Consumption-friendly driving » page 174 .
	Break recommendation » page 189 .
	Driving mode Normal » page 173 .
	Driving mode Eco » page 173 .
	Comfort Driving Mode » page 173 .
	Driving mode Individual » page 173 .
	Offroad driving mode » page 173 .
	Driving mode Sport » page 173 .
	Snow Driving Mode » page 173 .

Correct and safe

Introductory notes for correct use

- ▶ Read this Owner's Manual carefully, as proceeding in accordance with this manual is a prerequisite for the correct use of the vehicle. This Owner's Manual should therefore always be in the vehicle.
- ▶ When using the vehicle, the generally binding legal provisions that are specific to the country must be observed. Such as those for transporting children, switching off airbags, using tyres, road traffic and the like.
- ▶ Do not exceed the maximum permissible weights and loads.
- ▶ Do not exceed the maximum permissible roof load.
- ▶ Use the specified fuel and operating fluids.
- ▶ Drive on roads that meet the technical vehicle parameters. Obstacles that exceed the ground clearance of the vehicle » [page 238](#) can damage the vehicle when driving over them.
- ▶ Care must be taken during operations related to operation, maintenance and self-help to avoid damage to the vehicle or injury. If required, seek the help of a specialised garage.
- ▶ All work on the vehicle's safety systems may only be carried out by a specialist garage. This concerns e.g. the seat belts or the airbag system.
- ▶ When using accessories, please note the instructions in the accessory manufacturer's instruction manual. These include child seats, roof racks, compressors etc.
- ▶ Please note the service intervals.

New vehicle or new parts

New vehicle - Running in the engine

Driving style during the first 1500 km determines the quality of the engine run-in process.

- ▶ During the first 1000 km, rev the engine to max. 3/4 of the highest permissible engine speed and avoid using a trailer.
- ▶ Over the next 500 km, the engine speed can be slowly increased.

Depending on driving style and operating conditions, the engine consumes some oil, up to 0.5 l/1000 km. Consumption may be higher over the next 5000 km.

New brake pads

New brake pads do not provide the optimum braking effect during the first 200 km, they have to be worn in first. Therefore, drive very carefully.

New tyres

New tyres do not have optimum grip for the first 500 km. Therefore, drive very carefully.

Regular checks

What should be taken into account before driving?

A vehicle with technical defects can increase the risk of accidents and injuries.

Eliminate any defects before driving. If required, seek the help of a specialised garage.

Pay special attention to the following points:

- ▶ Is the tyre undamaged?
- ▶ Is the tyre tread sufficient?
- ▶ Is the tyre pressure sufficient?
- ▶ Do the headlights, brake and turn signals work?
- ▶ Is the windscreen in good condition?
- ▶ Is the engine oil, brake fluid and coolant level OK?
- ▶ Is the air intake in the engine compartment free from obstruction?
- ▶ Are the air outlet nozzles or air intake in front of the windscreen free from obstruction?
- ▶ Are the windscreen wiper and washer system and windscreen wiper blades functional?
- ▶ Is the windscreen washer fluid level sufficient?
- ▶ Are the windscreen wiper blades in good condition?
- ▶ Are all seatbelt system components in good working order? Are the seatbelts clean and have the buckles been unclogged?
- ▶ Is the spoiler working properly?
- ▶ Are parts and components of the vehicle still visibly attached?
- ▶ Are there no oil stains or other operating fluids under the vehicle?

Improper vehicle adjustments

Improper changes and maintenance can cause malfunctions and affect safety-relevant and other functions of the vehicle.

- ▶ Adjustments, repairs and technical changes to the vehicle should only be carried out by a specialist garage.
- ▶ Never cover the engine with additional insulation material, e.g. with a cover.

Keep sensors and cameras functional

Some functions of your vehicle are supported by sensors and cameras inside and outside the vehicle.

Accessories additionally installed on the vehicle rear, such as bicycle carriers, can impair the functioning of the sensors and cameras.

- ▶ Do not cover or stick over the sensors and cameras and keep them clean.

- ▶ If you suspect damaged sensors or cameras, seek the help of a specialist company.

Engine compartment

Before opening the engine compartment flap

Risk of scalding! Do not open the engine compartment flap if steam or coolant comes out of the engine compartment.

- ▶ Stop the engine and allow it to cool.
- ▶ Remove the ignition key. On vehicles with a keyless locking system, open the driver's door.

When working in the engine compartment

- ▶ Keep children away from the engine compartment.
- ▶ Do not touch the radiator fan. The radiator fan can turn itself on, even when the ignition is off.
- ▶ Do not touch electrical cables. Avoid short circuits in the electrical system, especially on the 12 Volt vehicle battery.
- ▶ Do not smoke near the vicinity of the engine and refrain from handling open flames or sparks.
- ▶ If you need to work in the engine compartment with the engine running, be mindful of rotating engine parts and electrical equipment.
- ▶ Do not leave any objects in the engine compartment.

Handling operating fluids

Your vehicle uses various operating fluids to operate that can affect health or the environment when they are emitted. These are fuel, oils, battery acid from the 12-volt vehicle battery, coolant and brake fluid or AdBlue®.

- ▶ Only use operating fluids outdoors or in well-ventilated areas. If required, wear protective equipment.
- ▶ Do not use or check operating fluids with the engine running.
- ▶ In the event of contact with operating fluids, wash affected areas with warm water. If required, seek medical help.
- ▶ The leaked engine oil in the engine compartment can cause a fire, so wipe it off with a cloth.
- ▶ Store cloths soiled by brake fluids in a well-ventilated place until disposal. Cloths with residues of engine oil can ignite and cause a fire.

12 volt vehicle battery

Handling the 12-volt vehicle battery

The battery acid of the 12-volt vehicle battery is very caustic. Improper handling of the 12 volt vehicle battery can cause an explosion, fire, chemical burns or poisoning!

- ▶ When handling the 12-volt vehicle battery, eye and skin protection must be worn.
- ▶ Do not tilt the 12-volt vehicle battery, as it may leak battery acid.
- ▶ If battery acid comes into contact with skin, wash the affected areas with water for a few minutes. Seek medical assistance without delay.
- ▶ Do not charge a frozen or thawed 12-volt vehicle battery. Replace a frozen 12-volt vehicle battery.
- ▶ Do not use a damaged 12-volt vehicle battery.
- ▶ Short circuit! The battery poles of the 12-volt vehicle battery are not connected.

Use electrical sockets in the vehicle

Improper handling of the sockets may lead to life-threatening electric shock or a fire.

- ▶ The sockets can become warm during operation. Do not touch warm sockets.
- ▶ Protect sockets from liquids.
- ▶ If moisture does manage to get into the power socket, completely dry out the socket before re-use.
- ▶ Do not insert any objects into the socket contacts.

Before your journey

Adults and children, cargo and objects - everything has its place in the vehicle. Observe the following instructions so that all occupants are protected in the best possible way in the event of an accident.

Before you go

- ▶ Ensure that you have a good view of outside the vehicle. Attach external devices (e.g. navigation system) so that they do not restrict the view externally.
- ▶ Adjust the rearview mirrors.
- ▶ Close all doors and the engine compartment and boot flap.
- ▶ Take up the correct sitting position, adjust the seats correctly and fasten the seat belt properly. Ensure that passengers do likewise. Always leave the seat belt on while driving.
- ▶ Only one person can be secured with a seat belt.
- ▶ Make sure that the seat belts are not trapped, e.g. in the door or in the seat.
- ▶ Check seat belts, their locks and attachment points for damage.

Sitting safely

For the safety of the occupants and to reduce the risk of injury in the event of an accident, the following instructions must be observed:

- ▶ Stand the backrests upright. If the front passenger seat backrest has been folded forward, only the seat behind the driver's seat may be used for transporting passengers.
- ▶ Engage the rear seat backrests correctly.
- ▶ Adjust the height-adjustable headrest so that the top of the headrest is as close as possible to the top of the head.
- ▶ On the occupied rear seat, the headrest should not be in the lower position although the upper edge of the headrest should be at the same height as the top of the head.
- ▶ Keep your feet in the footwell.
- ▶ Use the entire seat.
- ▶ Do not lean forward or sit to the side.
- ▶ Do not hold your limbs out the window.

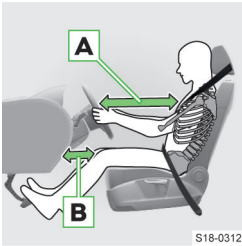

- ▶ Adjust the driver's seat in the longitudinal direction so that the pedals can be fully pushed through with slightly bent legs.
- ▶ Adjust the steering wheel so that the distance **A** between the steering wheel and sternum is at least 25

cm.

- ▶ For vehicles with driver's knee airbag, adjust the driver's seat longitudinally so that the distance **B** from the legs to the dash panel in the area of the knee airbag is at least 6 cm.
- ▶ Adjust the angle of the backrest so that the steering wheel can be reached at the top with your arms slightly bent.
- ▶ Move the passenger seat back as far as possible. The front passenger must maintain a minimum distance of 25 cm from the dash panel.

Correct belt webbing arrangement



The webbing arrangement is extremely important for the seat belts to offer the best possible protection.

- ▶ The shoulder strap must run over the middle of the shoulder, must never run over the neck, and must lie firmly against the body (it must not run over loose layers of clothing).
- ▶ The lap belt part must be placed in front of the pelvis and fit tightly.
- ▶ In pregnant women, the lap belt part must be as low as possible on the pelvis, so that no pressure is exercised on the abdomen.
- ▶ The webbing must not be pinched or twisted and rub against sharp edges.
- ▶ The webbing must not pass over solid or fragile objects in clothing, such as a key ring, etc.
- ▶ The tongue may only be inserted into the buckle of the associated seat.
- ▶ The webbing must be tight. Therefore, do not attach clamps or similar items to the webbing for adjusting the seat belt according to body size.

Correct steering wheel position



- ▶ Hold the steering wheel with both hands on the outer edge in the "9 o'clock" and "3 o'clock" position. Otherwise, you may experience serious injury to the arms, hands and head when deploying the airbag.

Securing children properly

- ▶ Do not carry a child on your lap, and secure the child and yourself with a seat belt.
- ▶ Only transport children in a suitable child seat » page 44.

Children under 150 cm tall will not be properly protected without a child seat. Children that have been inadequately secured can be thrown through the vehicle in the event of an accident or a sudden manoeuvre. You can cause life-threatening injuries to yourself and other occupants.

If children lean forward or assume a wrong sitting position while driving, they are more likely to be injured in the event of an accident. This is especially true for children who are carried in the passenger seat - when the airbag system triggers, they can be seriously injured or killed!

A child that has been incorrectly secured in the wrong sitting position - endangered by the side airbag



The child should not be in the deployment area of the side airbag.

A child that has been properly secured in a child seat



There must be enough room between the child and the exit area of the side airbag to offer the best possible protection.

Transporting objects safely

When moving heavy objects, there is a shift in emphasis. Thus, the driving behaviour of the vehicle changes.

- ▶ Adjust driving speed and driving style to this changed driving behaviour.

Unsecured or misplaced items may be thrown around in the event of an accident or sudden manoeuvre. There is a risk of serious injury and loss of control of the vehicle!

In a rear-end collision at 50 km/h unsecured objects are thrown forward with up to 50 times their weight. A 1.5 litre water bottle is thrown with up to 75 kg.

- ▶ Transport objects securely.
- ▶ Stow objects so they do not hinder the driver. Keep the driver footwell clear.
- ▶ Stow small items in the storage compartments.
- ▶ Do not leave lockable storage compartments open.
- ▶ Do not let items protrude out of the slots. This note does not apply to bottles in bottle trays.

- ▶ Do not place any objects on the dash panel or on the luggage compartment cover.
- ▶ Do not exceed the maximum permissible load of fasteners and shelves.
- ▶ Distribute the load evenly in the luggage compartment and secure it, so that it cannot slip.
- ▶ Place heavy objects in the luggage compartment as far forward as possible.

Safe driving

Introductory notes

- ▶ Pay attention when you are driving! As a driver, you are fully responsible for road safety.
- ▶ Always adjust driving speed to the road conditions as well as the traffic and weather conditions.

Paying attention to warning signals

The driver information system warns you with indicator lights and messages in the event of any faults. Failure to follow the warnings may increase the risk of accidents and injuries.

- ▶ If the vehicle issues a warning signal, then park the vehicle safely and follow the information in the instrument cluster, and in this Owner's Manual.

Use assistance systems

The assistance systems are only for support and do not absolve you from your responsibility for driving the vehicle.

The assistance systems are subject to physical and technical limitations. Therefore, in certain situations, system reactions may be perceived as undesirable or delayed.

- ▶ Stay alert and be ready to intervene.
- ▶ Familiarise yourself with the assistance systems, their limitations and operating conditions.
- ▶ Activate, deactivate and adjust the assistance systems so that you have full control of the vehicle in any traffic situation.

Driving with a substitute spare wheel or emergency wheel

A substitute spare wheel or emergency wheel is only used to reach the nearest specialist garage.

- ▶ Inflate the wheel with the max. prescribed inflation pressure.
- ▶ Follow the instructions on the warning label on the rim.
- ▶ Do not cover the warning sign.
- ▶ Avoid full accelerations, strong braking and fast cornering.
- ▶ Do not drive with more than one mounted spare wheel.
- ▶ Avoid using snow chains on the temporary spare wheel.

Driving with a loaded roof rack

When transporting objects on the roof rack, the vehicle's driving behaviour changes.

- ▶ Adapt your speed and driving style to this.

Towing a trailer

The vehicle's handling characteristics change with a trailer. The assistance systems may behave differently.

- ▶ Drive more slowly, excessive speed can lead to loss of control of the vehicle.
- ▶ Keep a larger distance from the vehicle in front.
- ▶ Do not exceed the max. vertical load and the permissible trailer load.

Driving through water

There must be no water ingress into the vehicle systems e.g. into the engine's air intake system!

- ▶ Therefore, determine the water depth before driving through water. The water level must not exceed the lower edge of the lower beam.
- ▶ Drive at max. walking speed. Otherwise, a wave may form in front of the vehicle, increasing the water level.
- ▶ Never stop in the water, do not drive backwards and never stop the engine.

Is something wrong?

- ▶ Pay attention to changes in vehicle handling.
- ▶ If in doubt about safety, stop driving and seek the help of a specialist garage.
- ▶ Unusual vibrations or the vehicle 'pulling' to the side may indicate a puncture.
- ▶ If tyre pressure loss is very quick, try to stop the vehicle carefully without heavy steering or heavy braking.
- ▶ Immediately remove foreign bodies stuck in the tyre tread.
- ▶ Do not remove foreign objects that have penetrated into the tyre. Check the tyre pressure and seek the help of a specialised garage.
- ▶ Immediately remove any objects jammed under the floor of the vehicle. These can damage the vehicle or ignite and cause a fire.

Stop the vehicle safely!

A vehicle that has not been secured may roll away and cause accidents.

- ▶ For parking, look for a place with suitable ground. Do not park the vehicle on flammable materials such as dried leaves, spilt fuel. Hot vehicle parts can cause a fire.

Carry out the following activities in the specified order when parking.

- › Stop the vehicle and keep the brake pedal depressed.
- › Secure the vehicle with the parking brake.
- › For vehicles with an automatic gearbox, put the selector lever in the **P** position.
- › Turn off the engine.
- › For vehicles with manual transmission, engage 1st gear or reverse gear.
- › Release the brake pedal.

Exiting the vehicle

Do not leave children unattended in the vehicle!

- ▶ Children may injure themselves when handling the seats, releasing the parking brake etc.
- ▶ In emergency situations, children are not able to leave the vehicle on their own or help themselves.
- ▶ At very high or very low temperatures, there is danger to life!
- ▶ When locking the vehicle, the SAFE function switches on. As a result, no doors or windows can be opened from the inside. Turn off the SAFE function if people are left behind in the locked vehicle » [page 24](#).

Deviating weather conditions

If you wish to operate your vehicle in countries with different weather conditions from those specified, please contact a ŠKODA partner. They will advise you if certain precautions need to be taken to ensure the full functioning of the vehicle or to prevent damage (e.g. coolant, 12 volt vehicle battery replacement, etc.).

Emergency call

What you should be mindful of

⚠ WARNING

Availability of a mobile network is indispensable for establishing a connection to the emergency number.

⚠ WARNING

This emergency service is only available in some countries.

⚠ WARNING

If the vehicle is located in an area without a functioning emergency call system infrastructure, no vehicle data shall be transmitted to the emergency call centre.

Functionality

After the start of the conversation, the emergency call centre also contains information as to the accident location and the severity of the accident, the number of occupants with seatbelts on and the vehicle identification number (VIN).

Once the connection has been established, communication with the emergency call centre takes place via the loudspeaker and microphone installed in the vehicle.

Serious accident - automatic call

In the event of an accident where the airbag or belt tensioner activates, a call is automatically started with the emergency call centre.

The automatic call to the emergency call centre is also started after the Emergency Assist assistant system has intervened.

Minor accident - call option

The Infotainment screen displays the option to set up a connection to the emergency call centre or breakdown service.

Indicator light

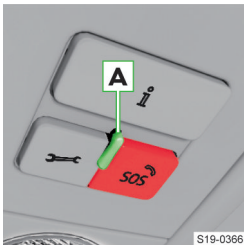

Version 1

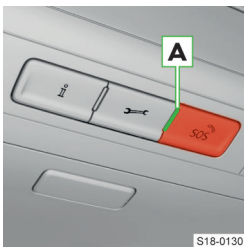

Version 2

The system status is displayed after the ignition is switched on, by the illumination of warning lamp **A**.

- ▶ Green - lit up - the system is functional
- ▶ Green - flashing - a call is being made to the emergency call centre
- ▶ Red - lit up - there is a system failure, immediately seek the help of a specialist garage
- ▶ Not lit up - the system is out of order due to a long term unavailable mobile network, if this circumstance persists, the system will require the assistance of a specialist garage

⚠ WARNING

If there is a system fault, no emergency call is possible.

Operation

Manual call



Version 1

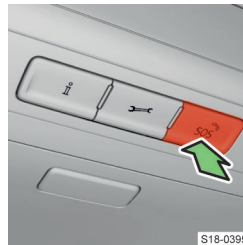

Version 2

- › Keep the SOS button pressed down.
- › Confirm the connection to the emergency call centre in the Infotainment screen.
- › To cancel the connection to the emergency call centre before starting the call, press the SOS button again or confirm the cancellation of the connection in the Infotainment screen.

Starting a manual conversation can then be used, for example, if you also report an accident in which you are not directly involved.

After an accident

What to do after an accident

Where possible, please observe the following instructions:

- › Switch off the ignition.
- › Turn on the hazard warning lights.
- › Put on the reflective vest.
- › Set up the warning triangle to warn other road users.
- › Stay at a safe distance from the vehicle, along with any passengers.
- › Report the accident to the emergency services.
- › Wait for the emergency services to arrive.

Safety systems

After an accident, the safety systems of the vehicle, e.g. seatbelts and airbag system, may be out of action.

- ▶ Have the vehicle's safety systems checked by a specialist garage, even if no load or trip has occurred.
- ▶ Have damaged, loaded or triggered components of the safety systems replaced by a specialist garage.

What to do in the event of a fire

Where possible, please observe the following instructions:

- › Switch off the ignition.
- › Turn on the hazard warning lights.

22 Correct and safe › After an accident

- › Put on the reflective vest.
- › Set up the warning triangle to warn other road users.
- › Stay at a safe distance from the vehicle, along with any passengers.
- › Report the fire to the emergency services.
- › Wait for the emergency services to arrive.

Keys, locks and alarm system

Key

Key Overview

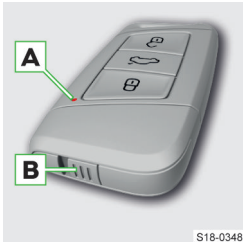

S18-0348

- Locking the vehicle
- Operating the boot lid
- Unlocking the vehicle
- A** Battery status warning light
- B** Locking tab for removal of the key bit

ⓘ NOTICE

- ▶ Protect the key from moisture and strong vibrations.
- ▶ Keep the grooves in the key clean.

i The effective range of the key signal is about 30 m. The effective range can be reduced, e.g. due to signal interference from other transmitters.

Removing the key bit

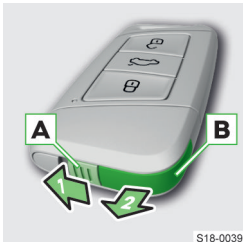

S18-0039

- › Unlock the securing tab **A**.
- › Remove the key bit **B**.



S18-0040

- ▶ A message stating it is necessary to change the battery will be displayed.
- › Replace the battery » page 23.

The vehicle cannot be unlocked or locked with the remote control

There may be the following reasons:

- ▶ The battery in the key is empty.
- › Replace the battery » page 23.
- ▶ The key is not synchronized.

Synchronize the key as follows:

- › Press any button on the key.
- › Unlock the door within 1 minute with the key via the locking cylinder » page 25.

i If necessary, the key must be synchronized if a favoured button on the key has been repeatedly pressed outside of the effective range of the remote control.

Changing the key battery

The new battery must comply with the specification of the original battery.

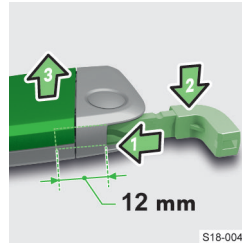

S18-0045

- › Remove the key bit and partially insert it into the opening.
- › Press down on the key fob to release the top cover.



S18-0046

- › Slide off the battery cover.

Troubleshooting

The battery in the key is almost empty

- ▶ After pressing a button on the key, the warning light does not flash.

Or:



S18-0047

- › Insert a thin screwdriver into the recess **A** and remove the battery.
- › Press any button on the remote key to re-set the key.
- › Insert the new battery.
- › Fit the battery cover and press until it clicks

into place.

⚠ WARNING

Risk of death!

If the battery is swallowed, serious or even fatal injuries can result from burns in the digestive tract.

- ▶ Always keep children away from the vehicle key and batteries.
- ▶ If the battery is swallowed, seek medical help immediately.

Memory function of the key

Functionality

Applies to vehicles that do not have the personalisation function.

Each time the vehicle is locked, the position of the driver's seat and rearview mirror are stored in the memory of the remote key being used to lock the vehicle.

Operation

Retrieve stored position

- › Unlock the vehicle and open the driver's door.

The driver's seat and the exterior mirrors occupy the position assigned in the memory to the key used to unlock the vehicle.

Stop position change

- › Press any button on the seat to be adjusted.

Or:

- › Press the button on the key.

Settings

Activate and deactivate the memory function of the key

The function is activated or deactivated in the following menu in the Infotainment system:

CAR > >

Or:

MENU > > >

Storing driver's seat and exterior mirror position for driving forwards

Storing takes place automatically every time the vehicle is locked.

ⓘ The seat position can be stored if the angle of inclination of the seat back relative to the seat surface is less than approximately 110° and the seat is not in any of the end positions.

Storing front passenger's exterior mirror position for reversing

- › Unlock the vehicle with the key.
- › Turn on the ignition.
- › Activate the folding function of the mirror in the Infotainment in the following menu:

CAR > >

Or:

MENU > > >

- › Turn the exterior mirror knob to the position **R**.
- › Engage reverse gear.
- › Adjust the mirror to the desired position.
- › Disengage reverse gear.

The set mirror position is saved.

Central locking

Functionality

Central locking system

The system unlocks and locks all doors, the fuel filler flap and the boot lid at the same time.

Unlock indicator: double flashing of the indicator lights.

Lock indicator: single flashing of the indicator lights.

The warning light in the driver's door will flash for about 2 seconds in quick succession after the vehicle is locked, then it will start flashing regularly at longer intervals.

ⓘ If none of the doors or the boot lid is opened within 45 seconds of unlocking, the vehicle automatically locks again.

SAFE function

Depending on the equipment, the central locking system can include the SAFE function.

The SAFE function prevents the doors from opening from the inside once the vehicle is locked.

The SAFE function is activated when the vehicle is locked from the outside.

In the display of the instrument cluster after the ignition is switched off, a message regarding the SAFE function is displayed.

⚠ DANGER

Risk of death!

- ▶ No people are allowed in the locked vehicle with the SAFE function.

Turn off the SAFE function

- ▶ By double locking within 2 seconds.

Or:

- ▶ Together with the deactivation of the interior monitoring » page 27, Settings.

The warning light in the driver's door will flash for about 2 seconds in quick succession after the vehicle is locked, then goes out and starts flashing regularly at longer intervals after about 30 secs.

When the SAFE function is switched off, the door can be opened from the inside by pulling once on the opening lever.

The SAFE function is switched on again after unlocking and locking the vehicle.

Operation**Ways in which central locking operates**

Depending upon vehicle equipment:

- ▶ Key » page 23
- ▶ Keyless locking (KESY) » page 26.
- ▶ Central locking button

Lock/unlock using the central locking button

- ▶ Press the  button in the centre console.

The  symbol in the button comes on when locked.

The button locks/unlocks all of the doors and the boot lid.

Unlocking of the vehicle also takes place when opening a door from the inside or when removing the key from the ignition.

⚠ WARNING

A locked vehicle with a central locking button makes it difficult for responders to enter the vehicle in an emergency.

Setting the unlocking and locking function

- ▶ In Infotainment, select the following menu:

CAR >  > 

Or:

MENU >  >  > 

All doors

Unlocking of all doors, the boot lid and the fuel filler flap.

Single door

Using the  button on the key, the driver's door and the fuel filler flap are unlocked.

In vehicles equipped with a keyless locking system, the door near to which the key is located and the fuel filler flap are unlocked by touching the door handle.

When unlocked again, the other doors and the boot lid are unlocked.

Doors on one side of the vehicle

Using the  button on the key, the doors on the driver's side and the fuel filler flap are unlocked.

In vehicles equipped with a keyless locking system, the doors on the passenger's side near to which the key is located and the fuel filler flap are unlocked by touching the door handle.

When unlocked again, the other doors and the boot lid are unlocked.

Automatic locking after starting

All doors and the boot lid are locked when a speed of 15 km/h is reached.

Unlocking of the vehicle takes place when opening a door from the inside or when removing the key from the ignition.

⚠ WARNING

An automatically locked vehicle makes it difficult for responders to enter the vehicle in an emergency.

Troubleshooting**Central locking fault**

- ▶ The warning light in the driver's door first flashes for 2 secs in quick succession.
- ▶ Then it lights up continuously.
- ▶ After 30 secs, it flashes slowly.
- ▶ Seek the help of a specialist garage.

Mechanically unlocking and locking the door**Unlocking and locking the door with the lock cylinder**

Remove the cover

- ▶ Pull on the door handle of the vehicle and hold it.
- ▶ Insert the key into the recess on the underside of the cover.
- ▶ Lift the cover in the direction of the arrow.
- ▶ Release the door handle.

S18-0037

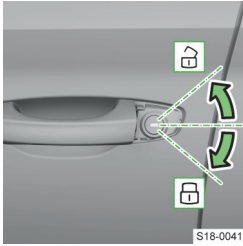

Locking and unlocking

- › Left-hand drive: Insert the key with the buttons facing **upwards** into the lock cylinder and unlock or lock.
- › Right-hand drive: Insert the key with the buttons facing **downwards** into the lock cylinder and unlock or

lock.

Install cover

- › Pull on the door handle and hold it.
- › Replace the cover.
- › Release the door handle.

Locking the door without the lock cylinder

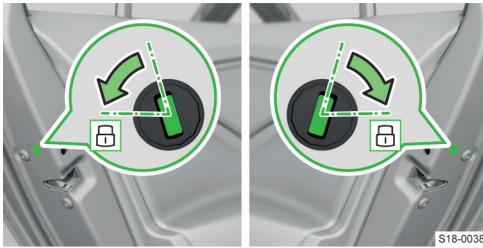

- › Open the door.
- › For vehicles with a panel over the opening, remove the panel.
- › Insert the key or a flat-head screwdriver into the slot.
- › Turn the key or flat-head screwdriver towards the outside of the vehicle (spring-loaded position).

After closing, the door is locked.

Keyless locking (KESSY)

Usage

The keyless locking system, KESSY, enables unlocking and locking of the vehicle without actively using the remote control key.

Operation

Keep the key with you when unlocking and locking.

The sensors on the handle are intended to be operated with bare hands, e.g. wearing gloves may affect the function of the sensors.

Release

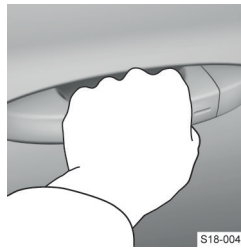

- › Grab the door handle.
- › Open the door.

Lock

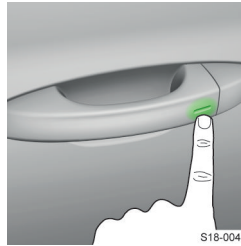

- › Touch the sensor.
- After locking, it is not possible to unlock within 2 seconds by touching the door handle. This can be used to check whether the vehicle is locked.

Unlocking the boot lid

- › Press the handle of the boot lid.

Protection against inadvertently locking the key in the vehicle

If the key is locked inside the vehicle, the vehicle will unlock itself automatically. If no door is opened within 45 seconds, the vehicle automatically locks again.

If the key is locked in the boot, the boot lid will automatically unlock itself.

Settings

Deactivate keyless locking

- › Lock the vehicle with the button  on the key.
- › Within 5 s, touch the sensor on the door handle with your finger.

Deactivation is confirmed by a single flash of the direction indicators.

- › To check the deactivation, wait at least 10 seconds and then pull the door handle.

The door must remain locked.

Keyless locking is automatically activated once again after the vehicle is unlocked.

Troubleshooting

The vehicle cannot be unlocked or locked using the sensors on the handle

- › Lock or unlock the vehicle with the button on the key.

- › Then try to unlock or lock the vehicle using the sensors on the handle.
- › If keyless locking does not work, seek the help of a specialist garage.

[i] If the vehicle is not unlocked for a longer period of time, the function can be deactivated automatically.

When the ignition was switched on, no key was found



illuminates

Message that no key was found in the vehicle

- › Insert the key into the vehicle.

Alarm system

Functionality

The alarm system triggers audible and visual signals during a break-in or towing attempt.

The alarm system is activated automatically approximately 30 seconds after the vehicle is locked.

The alarm system is automatically deactivated after the vehicle is unlocked.

Alarm triggering

The activated alarm system triggers an alarm when one of the following events occurs:

- ▶ Opening the bonnet
- ▶ Opening the boot lid
- ▶ Opening the door
- ▶ Manipulation of the ignition lock
- ▶ Towing the vehicle
- ▶ Movement in the vehicle
- ▶ Sudden and significant voltage drop of the electrical system
- ▶ Uncoupling the trailer
- ▶ Opening the door unlocked via the lock cylinder

Switching off the triggered alarm

- › Unlock the vehicle.

Or:

- › Turn on the ignition.

Operating conditions

For the correct functioning of the alarm system, all windows and the glasses compartment must be closed.

A trailer is integrated into the alarm system under the following conditions:

- ✓ The vehicle is factory-fitted with a towing device.
- ✓ The trailer is electrically connected to the vehicle via the trailer socket.

- ✓ The trailer is not equipped with LED taillights.

If the electrical connection to the trailer is interrupted on a vehicle with an activated alarm system, warning signals are triggered.

[i] Disable the alarm before connecting or disconnecting a trailer.

Settings

The following functions of the alarm system can be deactivated at the same time:

- ▶ Interior monitoring
- ▶ Towing protection

Deactivation will also switch off the SAFE function » page 24, *Functionality*.

Deactivation

- ▶ By double locking within 2 seconds.

Or:

- ▶ In infotainment in the menu **CAR** > > > Menu item for interior monitoring

Or:

- ▶ In infotainment in the menu **MENU** > > > > Menu item for interior monitoring

The deactivated functions are reactivated after the vehicle is unlocked and locked again.

[i] Deactivation is to be carried out if the vehicle is, for example, towed or transported.

Doors, windows and boot lid

Doors

Opening/closing the door

Opening from the outside

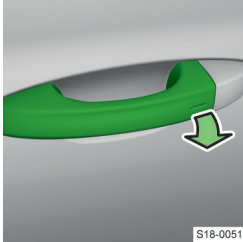

S18-0051

- › Unlock the vehicle and pull on the door handle.

Opening from the inside

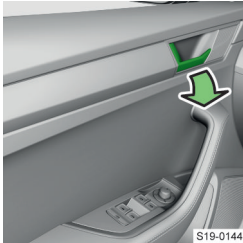

S19-0144

- › Pull the door opening lever and push the door away from you.

Closing from the inside

- › Grasp the pull handle and close the door.

Child safety lock on the rear doors

Operation

The child lock prevents the rear doors from being opened from the inside.

Switching on and off

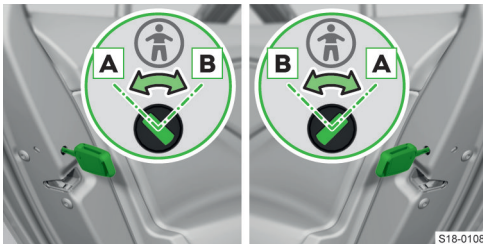

S18-0108

- › Turn the child lock with the vehicle key or a flat-head screwdriver.

A Child lock switched off

B Child lock switched on

Electrically operated child lock



- › Press the **left** button to switch on/off the child lock in the **left** rear door.

- › Press the **right** button to switch on/off the child lock in the **right** rear door.

The fact that the child lock is switched on can be seen by the illuminated  displayed in the button.

After switching on the child lock the electric window is also blocked in the respective door.

Window - with electrical operation

What you should be mindful of

Force limiter

To reduce the risk of pinch injuries when closing the windows, the vehicle has a force limiter.

If there is an obstacle, the window closing process is stopped and the pane retracts by several centimetres.

If the obstacle prevents it from being closed for the next 10 seconds, the closing process is interrupted once again and the window goes down by several centimetres.

If you attempt to close the window again within 10 seconds of the window being moved down for the second time, even though the obstacle was not yet been removed, the closing process is only stopped. During this time, it is not possible to automatically close the windows by pulling the button all the way. The force limiter is, however, switched on.

The force limiter is only not operational if you attempt to close the window again within the next 10 seconds – the window will now close with full force! If you wait longer than 10 seconds, the force limiter is switched on again.

⚠ CAUTION

Risk of injury!

- › Close the windows carefully, even though they have a force limiter.

Overview of the operating buttons on the driver's door

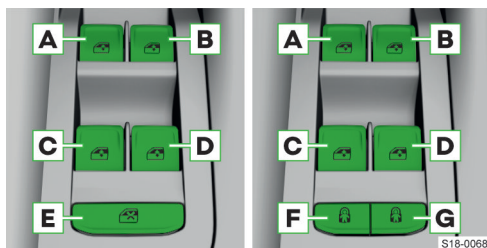

Depending upon vehicle equipment:

- A** Front left window
- B** Front right window
- C** Rear left window
- D** Rear right window
- E** Deactivation/activation of the buttons in the rear doors
- F** Deactivation/activation of the key in the left rear door (part of the child safety lock with electric operation) » [page 28, Operation](#)
- G** Deactivation/activation of the key in the right back door (part of the child safety lock with electric operation) » [page 28, Operation](#)

Operation

i When the windows are open, irritating noises may occur at certain speeds.

Opening

› Press the corresponding button slightly downwards and hold it until the window has reached the desired position.

Or:

› Press the corresponding button until it stops; the window opens automatically. Pressing the button again will stop the opening process.

Closing

› To close, pull gently upwards on the top edge of the corresponding button and hold until the window has reached the desired position.

Or:

› Pull the corresponding button until it stops; the window closes automatically. By pressing the button again, the closing process is stopped.

i After switching off the ignition, the windows can still open and close for about 10 minutes so long as none of the doors are opened.

Open all of the windows at the same time

› Press and hold the button on the key.

Or:

› Turn off the ignition, open the driver's door, and hold down the driver's window button until it stops.

Close all of the windows at the same time

› Press and hold the button on the key.

Or:

› Turn off the ignition, open the driver's door, and pull upwards on the driver's window button until it stops.

Or:

› For vehicles with a keyless locking system, hold one finger on the sensor on the outside of the handle on the front door.

Settings

The window operation is set in the following menu in the Infotainment system:

CAR › › › Menu item for window operation

Or:

MENU › › › Menu item for window operation

Troubleshooting

The window regulator has stopped working after repeated opening and closing

The window regulator mechanism could have overheated.

› Allow the window regulator mechanism to cool down.

The window operation does not work after disconnecting the 12 volt vehicle battery

› Enable window operation » [page 29](#).

Activation after disconnecting the 12-volt vehicle battery

Activate automatic window operation

› Turn on the ignition.

› Pull the corresponding button upwards and the window closes.

› Release the button.

› Pull up the respective button and hold for 1 second.

Sliding/tilting roof

What you should be mindful of

To reduce the risk of pinch injuries when closing the tilt/slide sunroof, the vehicle has a force limiter.

If the switch is held in the closed position and the closing process is hindered by an obstacle, the movement of the glass pane is stopped and the pane moves back a few centimetres.

If the obstacle is not removed, the power limit is deactivated when the switch is held again when the door is closed again (if the time span between the closing attempts is less than 5 s). The sliding/tilting roof will then close with full force.

⚠ CAUTION

Risk of injury!

- ▶ Close the sliding/tilting roof carefully, even though there is a force limiter.

🗨 NOTICE

- ▶ During winter time, if necessary, remove any ice and snow around the area of the sliding/tilting roof before opening.
- ▶ Always close the sliding/tilting roof before disconnecting the 12 volt vehicle battery.

Operating conditions

- ✓ Ignition is switched on.
- ✓ The outside temperature is higher than -20 °C (applicable for the opening of the sliding/tilting roof).

Operation

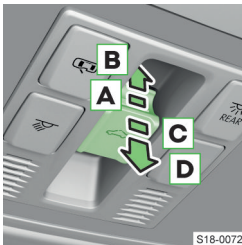

- A Gradual opening
- B Complete opening
- C Gradually reset
- D Fully reset

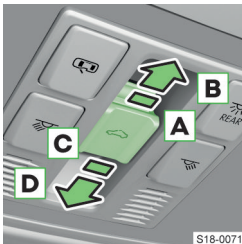

- A Gradual opening
- B Full opening
- C Gradual closing
- D Complete closing

1 After moving the switch to the position **B** the sliding/tilting roof is in the low-noise position (at a speed of about 80 km/h).

After another movement to position **B** the sliding/tilting roof opens completely.

1 After switching off the ignition, the sliding / tilting roof can be operated for about 10 minutes as long as none of the doors are opened.

Comfort operation of the tilting/sliding sunroof

The comfort operation makes it possible to lock the sliding/tilting roof with the key if necessary.

- › Press and hold the button to **turn it off**.
- › Press and hold the button to **close it**.

On vehicles with a keyless locking system, it is possible to **close** the sliding/tilting roof via the sensor in the door handle of the front door.

- › Hold one finger on the sensor on the outside of the handle on the front door » [page 26](#).

Troubleshooting

Operation of the sliding/tilting sunroof does not work after disconnecting the 12-volt vehicle battery

- › Activating operation of the sliding/tilting sunroof » [page 30](#).

Activation after disconnecting the 12-volt vehicle battery

Activating operation of the sliding/tilting sunroof



- › Turn on the ignition.
- › Pull the switch all the way down and hold it down.

After about 10 secs, the sliding/tilting roof opens and closes again.

- › Release the switch.

Sunblind - with electrical operation

Operation



- ☒ Opening
- ☒ Closing
- › Press or hold the button to **move** the roller blind.
- › Press or release the button to **stop** the roller blind from moving.

S19-0044

Activation after disconnecting the 12-volt vehicle battery

- › Turn on the ignition.
- › Keep the ☒ button pressed down. The sunblind opens and closes again.
- › Release the button.

Sun visors

Folding up and folding down

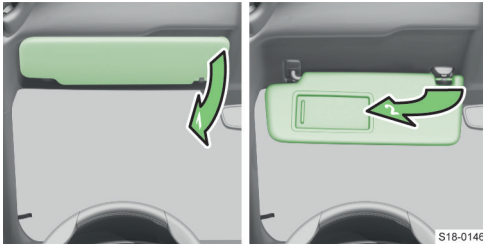

S18-0146

- 1 Swivel the front visor towards the windscreen
- 2 Swivel the visor towards the door

⚠ CAUTION

Objects attached to the sun visors can restrict the view to the outside. In the event of sudden braking or an impact, these can also cause injuries.

- ▶ Do not attach anything to the sun visor.

Boot lid - with manual operation

Operation

Opening

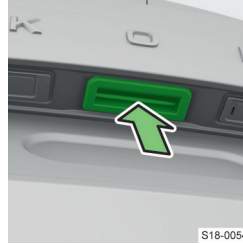

S18-0054

- › Press the handle and lift the lid.

The option to open by pressing the handle is deactivated once a speed of 5 km/h is reached. This is activated again after the vehicle has stopped and a door is opened.

Closing

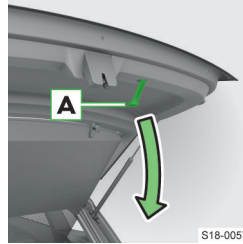

S18-0057

- › Grasp the fixture **A** and pull the lid down.

⚠ CAUTION

Danger of opening the tailgate while driving!

- ▶ Make sure that the latch engages after the flap is closed.

Set a delayed lid lock

If the lid is unlocked with the ☒ button on the key, the lid is automatically locked again after closing.

The period after which the lid is locked automatically can be extended by a specialist garage.

Boot lid - with electrical control

Operation

⚠ CAUTION

Risk of injury!

- ▶ Only operate the tailgate when there is nobody or no objects in the swivel area.

⚠ CAUTION

Danger of opening the tailgate while driving!

- ▶ Make sure that the latch engages after the flap is closed.

ⓘ NOTICE

- ▶ Do not manually close the tailgate when moving.
- ▶ Before operating the tailgate, check that there are no objects in the swivel area that could damage the tailgate. Also check that there are no objects within the immediate vicinity of the vehicle that could damage the vehicle interior and the transported objects.

ⓘ If the tailgate hits an obstacle when closing, it stops and an audible signal sounds.

ⓘ When automatically closing the tailgate, e.g. under the weight of snow, a broken beep sounds.

ⓘ The rear parking light flashing twice indicates that the flap is closed.

Handle in the tailgate



S18-0054

- ▶ Press the handle to open, close or stop the movement of the tailgate.

The option to open by pressing the handle is deactivated once a speed of 5 km/h is reached. This is activated again after the vehicle has stopped and a door

is opened.

Button in the tailgate

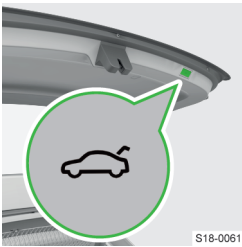

S18-0061

- ▶ Press the button to open, close or stop the movement of the tailgate.

Button in the door

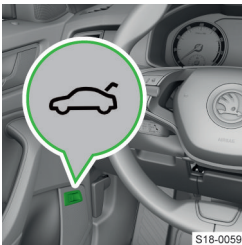

S18-0059

- ▶ To open the tailgate, pull and hold the button until the tailgate starts to open.
- ▶ To close the tailgate, pull and hold the button until the tailgate is fully closed.
- ▶ To stop the movement of the tailgate, pull or

release the button.

Button on the key



S19-0553

- ▶ Press the  button to open, close or stop the movement of the tailgate.

The option to lock exists only on vehicles with a keyless locking system. The key must not be in the vehicle and must be at a distance of max. 2 m from the tailgate.

ⓘ The tailgate can also be closed by pulling it briefly downwards.

Settings

Set the uppermost position of the tailgate and store it

It makes sense to set the top position of the tailgate, e.g. setting for the opening of the tailgate in a limited space due to the garage height.

- ▶ Stop the tailgate in the desired position.
- ▶ Press the  button and hold down on the lower edge of the tailgate until an audible signal sounds.

Re-adjusting the top starting position of the tailgate

- ▶ Carefully raise the tailgate manually to the limit.
- ▶ Press the  button and hold down on the lower edge of the tailgate until an audible signal sounds.

Troubleshooting

The tailgate does not react to the opening signal

- ▶ There is a possible obstacle, e.g. snow; remove it.

Or:

- ▶ Press the handle in the tailgate and lift the lid.

Or:

- ▶ Mechanically unlock the flap » page 33.

The tailgate does not react to the closing signal

- ▶ Close the tailgate manually.

ⓘ NOTICE

- ▶ Close the tailgate slowly, push down the tailgate and push in the lock on the centre of the rear edge of the tailgate.

Electrically operated contactless boot lid

Operating conditions

- ✓ Ignition off.
- ✓ You have the vehicle key with you.

- ✓ No trailer or other accessory is connected to the trailer socket.

- ▶ Maintenance and repair work in the back of the vehicle

Operation

Opening/closing the lid

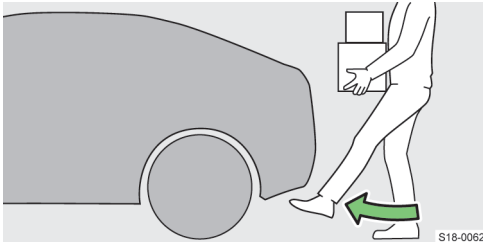

S18-0062

- › Stand in the middle behind the bumper.
- › Move one foot quickly under the bumper and remove it again.

If the lid doesn't move, wait a few seconds and repeat the swing motion.

Display of the opening/ closing process

The rear turn signal lights light up when the lid is opened and closed. When you close the lid, audible signals are additionally sounded.

Stopping/ restoring lid movement

The lid movement can be stopped by a rapid swinging motion with your foot. Lid movement is restored by a subsequent swinging motion with your foot.

Restriction

The system function may be restricted in the following cases:

- ▶ Downpour
- ▶ Dirty rear bumper

Settings

Activating and deactivating

The function is activated and deactivated in the following menu in the Infotainment:

CAR > >

Or:

MENU > > >

We recommend that the function is deactivated in the following cases:

- ▶ Installation of a roof rack
- ▶ Coupling a trailer or another accessory to the hitch
- ▶ Car wash

Unlocking the boot lid

Release

If the boot lid does not open, it can be unlocked manually by the following procedure.

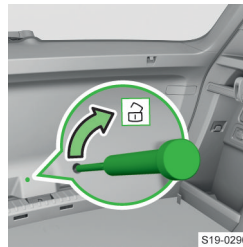

S19-0290

- › Insert a screwdriver into the opening in the panel.
- › Release the tailgate by moving it in the direction of the arrow.

Seats, steering wheel and mirror

Front seat - with manual operation

Controls on the seat

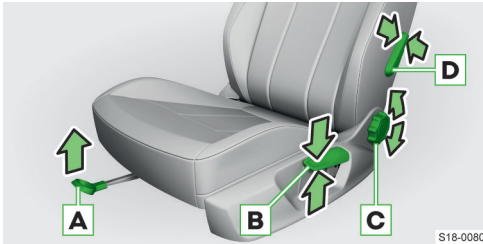

- A** Adjusting the seat in the longitudinal direction - after releasing the operating lever, the lock must audibly click into place
- B** Adjusting the height
- C** Adjusting the angle of the backrest - do not lean against the backrest during adjustment
- D** Adjusting the lumbar support: Extent of the curvature

After a certain time, play can develop within the adjustment mechanism of the backrest angle.

Folding passenger seat backrest

Folding down

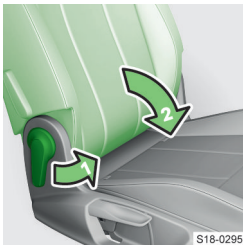

- › Pull on the operating lever.
- › Fold the backrest forwards until it clicks into place.

Folding back up

- › Pull on the operating lever.
- › Press the backrest backwards until it audibly clicks into place.

Front seat - with electrical operation

Controls on the seat

Adjusting the seat

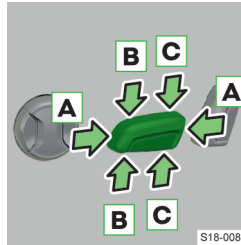

- A** Adjust in a longitudinal direction
- B** Adjust the inclination
- C** Adjusting the height

Adjusting the seat back

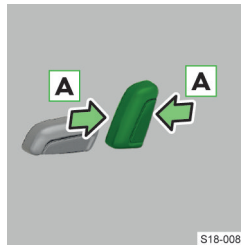

- A** Adjust the inclination

Adjusting the lumbar support

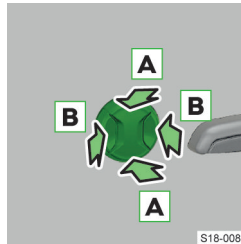

- A** Set the position of the curvature
- B** Set the extent of the curvature

Memory function of the seat

Functionality

Valid for vehicles with electrically adjustable driver's seat.

Each of the memory buttons on the driver's seat can be used to store and recall the set driver's seat and exterior mirror position.

Operation

Retrieve stored position

- › With the ignition off and the driver's door open, press the desired memory button.

- › In other instances, **hold** the button for example with the ignition switched on or the driver's door closed.

Stop position change

- › With the ignition off and the driver's door open, **press** any button on the seat to be adjusted.

Or:

- › Press the  button on the key.
- › In other cases, **release** the held memory button.

Settings

Storing driver's seat and exterior mirror position for driving forwards

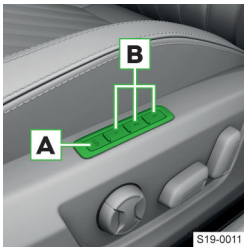

- › Turn on the ignition.
- › Adjust the seat and the exterior mirrors.
- › Press the button **A** and within 10 seconds one of the memory buttons **B**.

Storing is confirmed by an acoustic signal.



i The seat position can be stored if the angle of inclination of the seat back relative to the seat surface is less than approximately 110° and the seat is not in any of the end positions.

Storing front passenger's exterior mirror position for reversing

- › Turn on the ignition.
- › Activate the folding function of the mirror in the Infotainment in the following menu:

CAR >  > 

Or:

MENU >  >  > 

- › Turn the exterior mirror knob to the position **R**.
- › Engage reverse gear.
- › Adjust the mirror to the desired position.
- › Disengage reverse gear.

The set mirror position is saved.

i When changing the stored seat and exterior mirror position for forward driving, the passenger exterior mirror position for reverse driving must be re-stored.

Rear seats

Folding down the seat backs

Before folding down

- › Insert the rear headrests as far as they will go or remove them.
- › Adjust the position of the front seats in such a way that they are not damaged by the folded-down seat backrests.
- › Pull the outer seat belt to the side trim.

Folding forwards from the passenger compartment

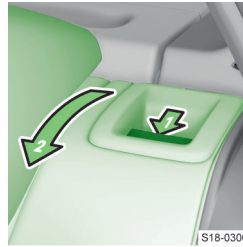

- › Press the release handle and fold the seat forwards.

Folding forwards from the boot



- › Pull on the lever. The seat back is unlocked and partly folded forwards.

Folding back up

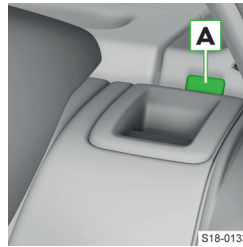

- › Pull the outer seat belt to the side trim.
- › Fold the seat backrest back up.

The release handle must audibly click into place.

- › Check that the seat backrest has locked in place. The pin **A** must not be visible.

Folding the backrests forward from the luggage compartment



Park position of rear seat belts

Applies to Varioflex seats.



VarioFlex rear seats

What you should be mindful of

Plugs and sockets under the seats

Depending on the equipment, plugs may be located on the underside of the seats and sockets with hinged protective plates may be located under the seats.

ⓘ NOTICE

Risk of damage or restriction to functionality of the plugs and sockets!

- ▶ Check the plugs or sockets for dirt before installing the seats. Remove dirt using a vacuum cleaner; clean the plugs and contacts with a cloth moistened in alcohol.
- ▶ If the seats are folded up or removed, carefully stack the items in the luggage compartment and do not load the sockets point by point.

Folding up the seat with the seat heating switched on

If the outer seat is folded up when the seat heating is switched on, the heater is interrupted. The heating can be switched on again after switching the ignition on and off.

Adjusting the seats

Move seats in a longitudinal direction

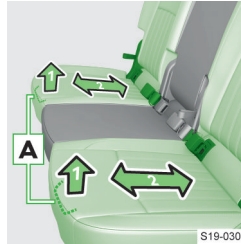

- ▶ Pull the lever **A** and move the seat.

The seat must audibly click into place.

Adjusting the inclination of the seat backrests

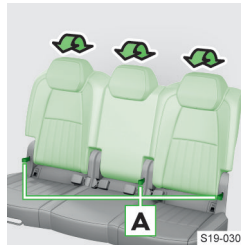

- ▶ Pull on the loop **A** and adjust the inclination of the seat backrests.

The rest must click into place.

Folding the backrests forwards and folding up the seats

Before folding the backrests forwards



- ▶ Insert the belt buckle of the seat belt into the opening in the side panel.
- ▶ Move the seats backwards as far as they will go.
- ▶ Insert the headrests as far as they will go.

Fold the backrests forwards

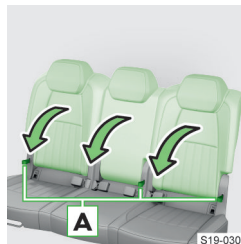

- ▶ Pull on the loop **A** and hold.
- ▶ Fold the backrest forwards until it clicks into place.
- ▶ Let go off the loop.

ⓘ The middle seat back, which is folded forwards, can be used as an armrest.

Before folding up the outer seat

- ▶ Move the seat back as far as it will go and fold the seat back.

- › Switch off the seat heating.

Fold up the outer seat

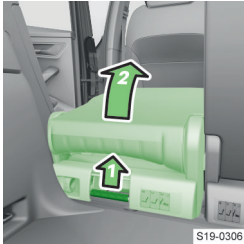

S19-0306

- › Pull the lever and carefully fold up the seat.

Before folding up the middle seat

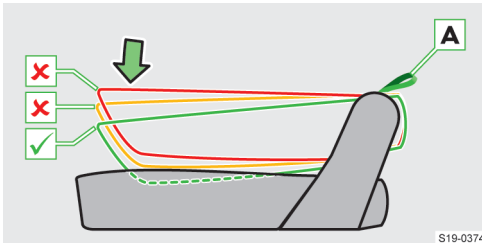

S19-0374

- › Removing the headrest.
- › Pull on the loop **A** and press the seat back into the position shown in green, about 4 cm deep into the seat.
- › Let go off the loop.

ⓘ NOTICE

Risk of damage to centre console components!
If the seat touches the centre console when folded up, the seat back is in the yellow or red position.

- ▶ Fold the seat back and push the seat back again into the position shown in green.

Folding up the middle seat

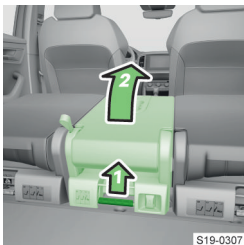

S19-0307

- › Pull the lever and carefully fold up the seat.

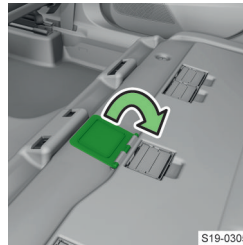

S19-0305

- › Close the cover cap for the socket in the floor.

Fold up the upholstered seats

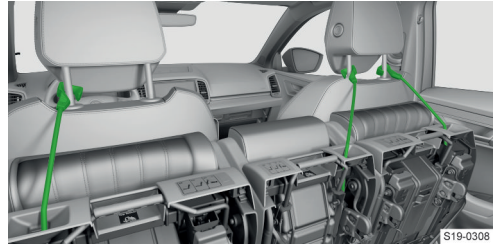

S19-0308

- › Lock the seats to the front headrest guide bar with the fastening strap.

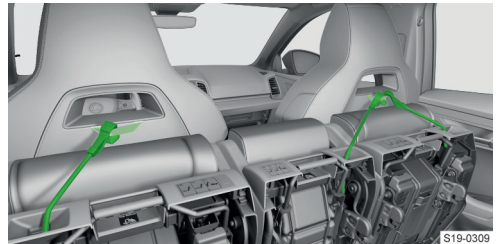

S19-0309

- › Lock the seats with the fastening strap on the loop at the rear of the front seat backrest.

⚠ WARNING

If one of the rear seats is folded up, passengers cannot be carried in the remaining rear seats.

ⓘ NOTICE

Risk of damage to the front seat backrests!

- ▶ Only keep the seats folded for as long as necessary.

Folding back seats

- › Before folding back the middle seat, open the cover cap for the socket outlet in the floor.
- › Carefully fold the raised seat into the horizontal position until it clicks into place.

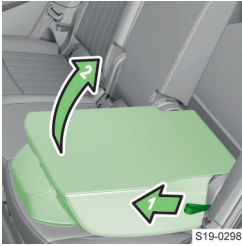

- › Pull on the loop.
- › Press the backrest backwards until it audibly clicks into place.

Insert and lock



- › Place the seat on the guide rods and lock in place using the seat locks.
- › Make sure that the seat cannot be removed.

Removing and inserting seats

Before removal

- › Move the outer seat backwards as far as it will go and fold up.
- › On the centre seat, remove the headrest and fold up the seat.

Unlock and remove

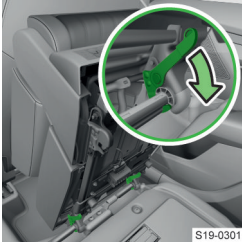

- › Unlock the seat by pressing on the seat locks.
- › Remove the seat from the carrying handle.

Folding back seats

- › Carefully fold the raised seat into the horizontal position until it clicks into place.

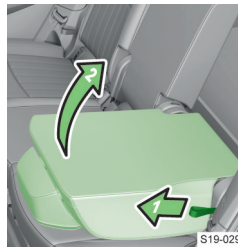

- › Pull on the loop.
- › Press the backrest backwards until it audibly clicks into place.



- › After removing the middle seat, close the cover cap for the socket outlet in the floor.

Move outer seats in the transverse direction

Before moving

- › Take out the middle seat.
- › Close the cover cap for the socket in the floor.

Moving

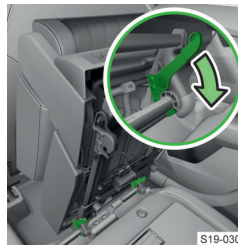

- › Fold up the outer seat and release it by pressing the seat locks.
- › Move seat on the guide rods towards the middle of the vehicle up to the stop.

Before inserting

The outer seats are not mutually interchangeable.

- › Insert the seat marked with the letter L in the rear on the left and the seat marked with the letter R in the rear on the right.
- › Before inserting the middle seat, open the cover cap for the socket outlet in the floor.



- › Lock the seat at the end of the guide rods by pressing the seat locks.
- › Make sure that the seat cannot be removed.
- › Carefully fold the raised seat into the horizontal position until it clicks into place.

Folding back into the starting position is accomplished in the reverse order.

Headrests

Adjusting the headrests

Front headrests

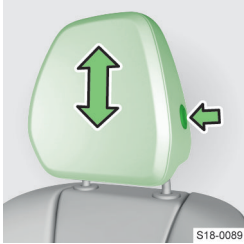

- › Hold the safety button and move the headrest in the desired direction.

Rear headrests

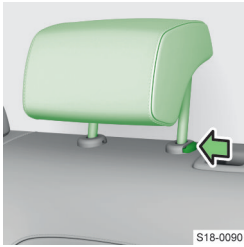

- › Move the headrest in the desired direction. When pushing down, press and hold the safety button.

Removing and inserting the rear headrests

Removing

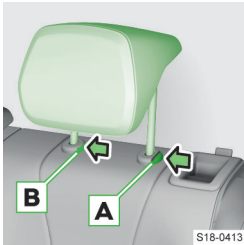

- › Move the headrest up to the stop.
- › Hold safety button **A** and, at the same time, push safety button **B** into the opening with a flat-head screwdriver and remove the headrest.

› To remove the support for the middle VarioFlex seat, press the safety button **A** and remove the support.

Inserting

- › Insert the headrest into the seat backrest. The safety button must click into place.

Front armrest

Settings

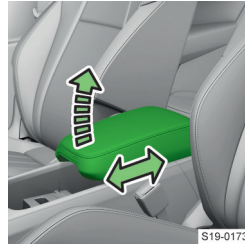

- Adjusting the height
 - › Raise the backrest to one of the locked positions.
- Folding down
 - › Raise the backrest beyond the highest locked position and fold it down again.
- Adjust in a longitudinal

direction

- › Move the backrest to the desired position.

Rear armrest

Settings



- › Fold down the armrest. The folded-down armrest can be used as a storage table.

Load-through device

Open and close

Open from the passenger compartment



- › Press the lid in the upper area and pull on the handle.
- › Open the lid.

Open from the luggage compartment

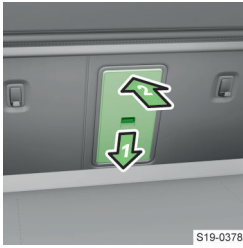

S19-0378

- › Press the store button.
- › Open the lid.

Closing

- › Fold back the lid from the passenger compartment until it clicks into place.

After closing, the red mark on the back of the cover above the safety button must not be visible.

⚠ WARNING

- ▶ The through-loading channel is only intended for transporting skis in a secured through-loading bag.

Steering wheel

Buttons/dials on the multifunction steering wheel

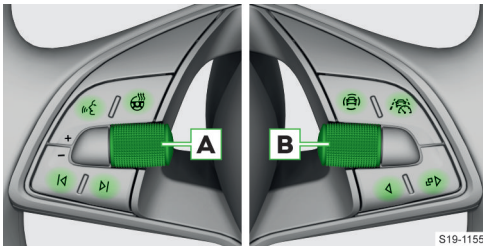

S19-1155

- Ⓜ Switch voice control on/off
- 🔥 Heated steering wheel » page 64
- A** **Rotate** - Adjust the volume
- Press** - Switch the sound off/on
- ⏪ Switch to the next track/station played
- ⏩ Switch to the previous track/station played
- ☰ Show menu of assistance systems
- 🚗 Switching the Travel Assist assistance system on / off » page 186
- B** Depending upon vehicle equipment:
 - ▶ Operating an analogue instrument cluster » page 65
 - ▶ Operating a digital instrument cluster » page 66
- Ⓜ Depending upon vehicle equipment:
 - ▶ Operating an analogue instrument cluster » page 65

- ▶ Operating a digital instrument cluster » page 66
- ⏪ Depending upon vehicle equipment:
 - ▶ Operating an analogue instrument cluster » page 65
 - ▶ Operating a digital instrument cluster » page 66

Setting the steering wheel position

⚠ WARNING

Risk of an accident!

- ▶ Do not adjust the steering wheel while driving.



S18-0092

- › Swing the safety lever downwards.



S18-0093

- › Adjust the steering wheel to the desired position.



S18-0094

- › Press the safety lever as far as it will go.

Troubleshooting

Power assisted steering faulty

! illuminates - total failure of the power assisted steering, failure of steering assistance

- › Turn off the ignition, start the engine and drive a few meters.
- › If the indicator light **!** does not go out, do not continue driving. Seek the help of a specialist garage.

! illuminates - partial failure of the power assisted steering, possible reduction in power steering

- › Turn off the ignition, start the engine and drive a few meters.
- › If the indicator light **!** does not go out, you can drive on, exercising appropriate caution. Seek the help of a specialist garage.

Steering column lock faulty

 flashes
Message regarding a fault in the steering column lock

- › Stop the vehicle.
- › Seek the help of a specialist garage.

After switching off the ignition, it is then no longer possible to switch on the ignition, to lock the steering and to switch on the electrical components.

 flashes
Message regarding a fault in the steering lock

- › You may continue driving, exercising appropriate caution. Seek the help of a specialist garage.

Steering column lock not unlocked

 flashes
Message concerning the required steering wheel movement

- › Move the steering wheel slightly back and forth.
- › If the steering does not unlock, stop the vehicle and seek the help of a specialist garage.

Interior rear-view mirror

Operation

Interior mirror with manual darkening



A Mirror is not darkened

B Mirror darkens

Interior mirror with automatic darkening

Darkening of the mirror is automatically controlled through the sensors in the mirror once the engine is started.

⚠ CAUTION

Risk of an accident!

A glowing display e.g. a mobile phone or navigation device may affect the function of the automatic mirror darkening.

- ▶ Do not attach these devices close to the mirror.



Wing mirror

Operation

Depending on the equipment, the mirrors can be folded in manually or electrically.

Positions of the rotary knob



- L** Adjust the left-hand exterior mirror
- O** Switch off operation
- R** Adjust the right-hand exterior mirror
-  **I** Fold mirror in electrically (to fold back out, select a different position)
-  Heat the mirror

when the engine is running

Adjusting the mirror surface

- › Select position **L** or **R**.
- › Turn the rotary knob in the direction of the arrows.

Folding electrically folding mirrors automatically

If this function is activated, the mirrors are folded in when the vehicle is locked and folded back when it is unlocked.

 Locking of the vehicle is not indicated by the fact that the mirrors fold in. Locking of the vehicle is indicated by the turn signal lights flashing.

Manually foldable mirrors

- › Fold the mirror towards the side window by applying pressure with your hand.

Setting the mirror surfaces synchronously

If this function is activated, the mirror surface of the passenger mirror is also set when the mirror surface of the driver's mirror is set.

Mirror with memory function

Valid for vehicles with electrically adjustable driver's seat.

The current setting for the exterior mirror surfaces can be stored in the memory of the driver's seat » [page 35](#) or the remote key » [page 24](#).

Lower the passenger mirror surface when reversing

Valid for vehicles with electrically adjustable driver's seat.

The mirror surface of the passenger mirror takes in the memory of the driver's seat » [page 35](#) or the remote key » [page 24](#) stored position to improve visibility when reversing.

Operating conditions

- ✓ The function can be activated in Infotainment.
- ✓ The mirror position is saved.
- ✓ The reverse gear is engaged.
- ✓ The adjustment knob is in the **R** position.

The mirror automatically resumes the home position when driving forward at speeds above 15 km/h or after the ignition is switched off.

⚠ WARNING

Risk of an accident!

The exterior mirrors make objects appear farther away.

- ▶ Use the rear-view mirror to determine the distance from vehicles behind.

ⓘ NOTICE

Danger of mirror damage!

- ▶ If the electrically foldable mirror is swung out by external influences (e.g. due to an impact during manoeuvring), fold the mirror in using the rotary knob and wait for an audible folding sound.

Settings

Activation or deactivation of the automatic folding of the exterior mirrors, the synchronous adjustment of the mirror surfaces as well as the lowering of the passenger-side mirror surface when reversing are carried out in the Infotainment in the following menu:

CAR >  > 

Or:

MENU >  >  > 

Troubleshooting**Electric mirror operation impaired**

- ▶ Adjust the mirror surface by pressing it lightly with your finger.

⚠ CAUTION

Risk of burns!

- ▶ Do not touch heated exterior mirror surfaces.

Restraint systems and airbags**Seat belts****Functionality**

Seat belts that are fastened correctly offer very good protection in the event of an accident. They reduce the risk of an injury and increase the chance of survival in the event of a major accident.

⚠ WARNING

- ▶ The seat belts must not be removed or altered in any other way.
- ▶ If the driver's seat belt is damaged, stop driving.
- ▶ If another seat belt is damaged, the seat must not be occupied.
- ▶ Do not repair damaged seat belts yourself.
- ▶ Have a damaged seat belt replaced immediately by a specialist garage.

Automatic belt retractor

The automatic retractor locks the belt in the event of a jerky pull on the belt. The belts lock, for example, when full braking, when the car accelerates, when driving downhill and when cornering.

⚠ WARNING

- ▶ If the seat belt does not lock when pulled jerkily, have the retractor checked by a specialist garage.

Belt tensioners

The safety of the driver, front passenger and passengers on the outer rear seats **who are wearing their seat belts** is enhanced by the belt tensioners fitted to the inertia reels on the front and rear external seat belts.

If there is a collision with a certain severity, the seat belt is tightened by the belt tensioner so that unwanted body movement is prevented.

The belt tensioner can also be deployed when the seat belt is not fastened.

Belt tensioners are **not activated** in the event of a roll-over, **minor** collisions or in accidents in which no major forces are produced.

[!] Smoke is released when the belt tensioner is deployed. This does not indicate a vehicle fire.







Reversible belt tensioner

Vehicles with a proactive occupant protection system include reversible belt tensioners » [page 189](#).

The reversible belt tensioners increase safety for the belted driver and front passenger by automatically tightening the seat belt tightly over the body in critical driving situations and then releasing it again.

Status display in the instrument cluster display

Depending on the type of display, the display can be as follows:

-  illuminated – a front or rear seat belt is not fastened
-  lights up - rear seat not occupied
-  illuminated – a rear seat belt is not fastened
-  illuminated – a rear seat belt is not fastened
-  illuminated – a rear seat belt is fastened.
-  illuminated – a rear seat belt is fastened.
-  illuminated – a rear seat belt is fastened.

- › Insert the buckle latch **A** into the buckle until there is an audible click.
- › Use the buckle latch **B** to slowly pull the belt over your chest and pelvis.
- › Insert the buckle latch **B** into the second buckle until there is an audible click.
- › Pull on the belt to ensure that the buckle latch is securely fastened.
- › **To take it off** take the buckle latch **A** and release by pressing the red button.
- › Grasp the buckle latch **A** and release it by pressing the red button.
- › Hold the belt so it does not twist when rolling up.

Operation

Fastening the seat belt

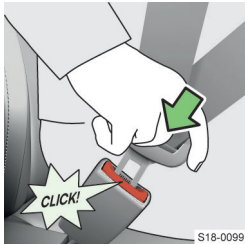

- › Grasp the buckle latch and slowly pull the belt over the chest and pelvis towards the buckle.
- › Insert the buckle latch into the buckle until there is an audible click.
- › Pull on the belt to ensure that the buckle is securely fastened.

Unfastening the seat belt

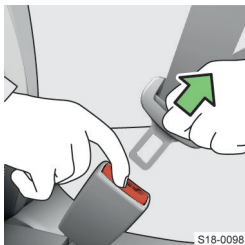

- › Grasp the buckle latch and release it by pressing the red button.
- › Hold the belt so it does not twist when rolling up.

Settings

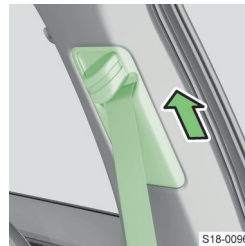

- › Move the seat belt height adjuster upwards to increase the height.

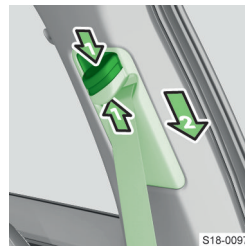

- › Press the safety button and move the seat belt height adjuster down to reduce the height.
- › After adjustment, firmly pull on the belt to ensure that the seat belt height adjuster has correctly locked in place and that the belt is locked securely.

Put on belt with two buckle latches and put down

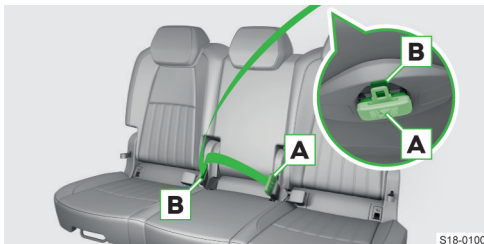

- › Pull the belt slowly by the buckle latch **A** to put it on.

Troubleshooting

Blocked belt retractor



- › Grasp the strap in the middle and pull quickly.
- › Hold the strap and let it roll up slowly.
- › Pull on the strap to see if the retractor is working properly.
- › If the strap is still blocked, repeat the unlocking procedure once or twice.
- › If the strap is still blocked, seek the help of a specialist garage.

Child seat

What you should be mindful of

For how to install and use the child seat, please note the instructions in this Owner's Manual as well as the instructions of the child seat manufacturer.

For safety reasons, we always recommend that children are transported on the back seats. Carry children on the front passenger seat only in exceptional cases.

Use child seats according to standard ECE-R 44 and ECE-R 129 of the European Economic Commission.

Child seats according to standard ECE-R 44 and ECE-R 129 are marked with the test symbol: large E in a circle, with the test number below.

We recommend using child seats from the ŠKODA Original Accessories range. These child seats have been developed and tested for use in ŠKODA vehicles. They satisfy the standard ECE-R 44 or ECE-R 129.

⚠ WARNING

- ▶ When installing the child seat on the rear seat, adjust the front seat so that there is no contact between the front seat and the child seat or the child carried in the child seat.
- ▶ Before installing a forward-facing child seat, adjust the headrest so that it is as low as possible.
- ▶ If the headrest prevents the child seat from being fitted, adjust the headrest to the highest position.
- ▶ When installing the child seat, avoid contact between the roof and the rear pillar. If the head airbag is deployed, there is a risk of injury.
- ▶ If using a separate child seat cushion, adjust the headrest so that the child's head is flush with, but not protruding above the height of the top edge of the headrest.

Using a child seat on the front passenger seat

When using a child seat on the passenger seat, any country-specific regulations must be observed.

Never use a child seat in which the child is carried with his or her back to the direction of travel on a seat protected by an active airbag placed in front of the seat. This could cause serious injury to the child, even death.

Recommended child seats

Grouping of child seats according to standard ECE-R 44.

This is also indicated by the following stickers:



- Ⓐ Sticker on the passenger sun visor
- Ⓑ Sticker on the central body pillar on the passenger side

The following instructions must be followed when using a child seat on the front passenger seat:

- ▶ It is essential to deactivate the front passenger airbag if using a child seat in which the child is transported with its back facing the direction of travel » page 48.
- ▶ If possible, adjust the front passenger seat backrest so that it is vertical, to ensure that there is secure contact between the backrest and the child seat.
- ▶ If possible, move the front passenger seat backwards so that there is no contact between the front passenger seat and the child seat behind it.
- ▶ Adjust the height-adjustable front passenger seat as much as possible.
- ▶ Set the front passenger seat belt as high up as possible.

⚠ WARNING

Risk of the seat belt causing a neck injury to the transported child!

- ▶ For child seats in groups 2 and 3, ensure that the guide fitting attached to the child seat headrest is positioned in front of or at the same height as the seat belt height adjuster on the central body pillar.
- ▶ Adjust the height of the front passenger seat belt so that the belt passes through the guide fitting without kinking and is not bent over the edge of the guide fitting.

⚠ WARNING

- ▶ As soon as the rear-facing child seat is no longer being used on the front passenger seat, activate the front passenger airbag again.

Group	Weight of the child
0	up to 10 kg
0+	up to 13 kg
1	9-18 kg
2	15-25 kg
3	22-36 kg

Recommended child seats

Group	Manufacturer	Type	Attachment	Order number	Approval number (E1 ...)
0+ (up to 13 kg)	Britax Römer	Baby Safe Plus	Isofix base frame	1ST019907	04 301146
1 (9-18 kg)	Britax Römer	Duo Plus TT	ISOFIX and TOP TETHER	DDA000006	04 301133
2-3 (15-36 kg)	Britax Römer	Kidfix XP ^{a)}	ISOFIX	000019906K	04 301198
	Britax Römer	Kidfix II XP	ISOFIX	000019906L	04 301323

^{a)} For optimum protection, especially in the event of a side impact, it is recommended that you use this child seat complete with the backrest.

Fasteners for child seats

Use of child seats

Overview of usability of child seats according to standard ECE-R 16.

Child seats with the ISOFIX system

Group	Size category of child seat ^{a)}	Front passenger's seat		Rear seats	
		With activated front airbag ^{b)}	With deactivated front airbag ^{b)}	Outer seats ^{c)}	Centre seat
0 (up to 10 kg)	E	X	X	IL	X
0+ (up to 13 kg)	E D C	X	X	IL	X
1 (9-18 kg)	D C B B1 A	X	X	IL IUF	X
2 (15-25 kg)	-	X	X	IL	X
3 (22-36 kg)	-	X	X	IL	X

^{a)} The size category of the child seat is indicated on the child seat plate.
^{b)} If the passenger seat is equipped with ISOFIX system holding eyelets, it is suitable for the installation of an ISOFIX child seat with "Semi-Universal" approval.
^{c)} The seat is suitable for the fixing system ISO/R3.

IL The seat is suitable for the ISOFIX child seats with "Semi-Universal" approval.

IUF The seat is suitable for forward-facing child seats and is permitted for use in this weight category.

X The seat is not equipped with eyelets for the ISOFIX system.

i-Size

Front passenger's seat		Rear seats	
With activated front air-bag	With deactivated front airbag	Outer seats	Centre seat
X	X	i-U	X

i-UF The seat is suitable for forward- and backward-facing i-Size child seats of the "Universal" category.

X The seat is not suitable for i-Size child seats of the "Universal" category.

Child seat fastened with a safety belt

Group	Front passenger's seat		Rear seats	
	With activated front airbag	With deactivated front airbag	Outer seats	Centre seat ^{a)}
0 (up to 10 kg)	X	U ^{b)}	U	U
0+ (up to 13 kg)	X	U ^{b)}	U	U
1 (9-18 kg)	UF	U	U	U
2 (15-25 kg)	UF	U	U	U
3 (22-36 kg)	UF	U	U	U

^{a)} It is forbidden to install a child seat with a support foot in the middle rear seat.
^{b)} Adjust the height-adjustable front passenger seat as much as possible.

U The seat is suitable for the child seat category "Universal" and is permitted for use in this weight group.

UF The seat is suitable for forward-facing child seats in the "Universal" category and is permitted for use in this weight group.

X The seat is not suitable for children in this weight group.

Overview

ISOFIX

⚠ WARNING

- ▶ On the retaining eyelets that are used to install the child seat with the ISOFIX system provided, do not attach any other child seats, belts or objects.

The ISOFIX system allows for the fast and secure installation of the child seat. The eyelets for installing the child seat using the ISOFIX system are located on the outer rear seats and possibly on the front passenger seat.

A child seat that uses the ISOFIX system can only be installed in the vehicle if it is approved for this vehicle type. Further information can be obtained from a ŠKODA partner or from a list of vehicles enclosed with the child seat.



Holding eyes for installing the child seat using the ISOFIX system.

S18-0114

TOP TETHER

⚠ WARNING

- ▶ Child seats with the TOP TETHER- Only use the system on the seats with the eyelets TOP TETHER-Symbol are provided.
- ▶ Only attach one belt from the child seat to a locking eye TOP TETHER-Fasten the system.
- ▶ When attaching the child seat with the TOP TETHER- No other object may be attached to the eyelet TOP TETHERSystem.

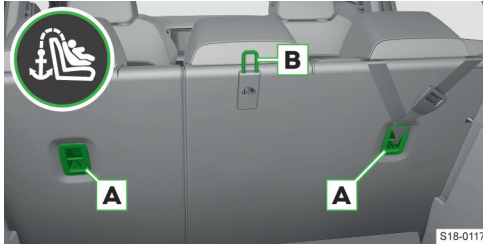

Holding eyelets on the rear seats



Holding eyelets on the VarioFlex rear seats

The belt fastened into the TOP TETHER system restricts the movement of the upper part of the child seat.

The holding eyelets for attaching the belt are located on the outer rear seats **A**, as well as on the middle rear seat **B** when necessary.

Airbags

Usage

The airbag system provides, as a supplement to the seat belts, additional occupant protection during severe frontal and side-on collisions.

The best possible protective effect of the airbag is achieved only when the seat belt is also worn. The airbag system is no substitute for the seat belts.

What you should be mindful of

Airbag systems can only properly protect if all occupants have been secured and they are in the correct seating position.

No persons, animals or objects such as cup holders or hangers for clothes may be in the deployment area of the airbags » page 47.

- ▶ Do not cover or stick anything over the steering wheel or the dash panel. The front airbags were not able to deploy.

The front passenger airbag should be switched off in some situations » page 48.

Functionality

When sinking into the inflated airbag, the forward movement of the body is damped and the risk of injury is reduced.

i As the airbags inflate, smoke is released. This does not indicate a vehicle fire.

Airbag deployment in the event of an accident

Airbag deployment is influenced by many factors. The deceleration rate at the time of impact is crucial.

⚠ WARNING

Danger of serious or fatal injuries!

- ▶ Maintain the correct seating position.
- ▶ Do not keep your limbs in the deployment area of the airbags.

In the following situations, **no** airbags are deployed:

- ▶ Minor frontal and side collisions
- ▶ Rear-end collision
- ▶ Vehicle rollover

If the measured deceleration rate is below the reference values programmed into the control unit, the airbags will not be deployed despite possible serious vehicle damage.

Airbag overview

The installation location of the airbags is marked with the lettering **AIRBAG**.

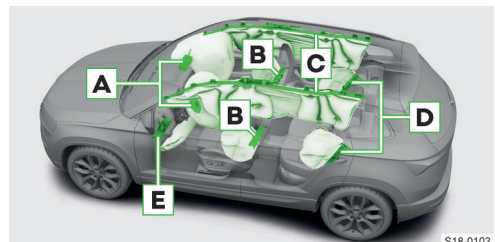

S18-0103

- A** Front airbags
- B** Side airbags - front
- C** Head airbags
- D** Side airbags - rear
- E** Driver's knee airbag

⚠ WARNING

Danger of a functional restriction of the side airbags!

- ▶ Do not exert excessive forces, e.g. impacts, on the seat backs.
- ▶ Do not use seat covers that have not been approved by ŠKODA.
- ▶ Have damaged seat covers at the installation location of the side airbags repaired by a specialist garage.

Deactivating the airbags

We recommend having airbags other than the front passenger airbag deactivated » page 48, *Operation* by a ŠKODA service partner.

Deactivation of the airbags should be considered in cases such as the ones below:

- ▶ If the driver's seat adjustment is correct, the distance of at least 25 cm between the centre of the steering wheel and the sternum cannot be maintained.
- ▶ Additional operating controls for a physically disadvantaged driver are installed in the vehicle.
- ▶ The vehicle has special seats, e.g. orthopaedic seats without side airbags.



illuminates for 4 seconds after the ignition is switched on and then flashes for 12 seconds

- Airbag or belt tensioner deactivated with the diagnostic device

Message regarding the deactivated airbag or belt tensioner

⚠ WARNING

If an airbag is deactivated during the sale of the vehicle, inform the buyer!

Requirements

- ✓ Ignition on

Troubleshooting

Airbag system faulty



illuminates

Message regarding an airbag fault

- ▶ Seek the help of a specialist garage.

Key switch for the front passenger airbag

Usage

Deactivation of the front passenger airbag is provided for the following cases, for example:

- ▶ A rear-facing child seat is mounted on the front passenger seat.
- ▶ The minimum distance to the control panel cannot be maintained.

What you should be mindful of

⚠ WARNING

Danger of fault in the passenger airbag deactivation system!

- ▶ Only switch off the airbag when the ignition is switched off.

⚠ WARNING

Danger of unexpected deployment of the passenger airbags in an accident!

- ▶ After switching off the passenger airbag with the key bit, do not leave the key bit inserted in the key switch while driving. Shocks can cause the Key assignment to turn in the slot and trigger the airbag.

Operation

Before switching off/switching on the front passenger airbag

- ▶ Remove the key bit.

Switch front passenger front airbag on/off



- ▶ Switch off the ignition.
- ▶ Open the passenger door.
- ▶ Insert the key bit into the slot in the key switch as far as it will go.
- ▶ To **Switch off**, carefully rotate the key switch into the position **OFF**.

- ▶ To **Switch on**, carefully rotate the key switch into the position **ON**.
- ▶ Remove the key bit from the slot.
- ▶ Close the passenger door.
- ▶ Turn on the ignition and check that the front passenger airbag indicator lights are lit up.

Warning lights



- ▶ After switching on the ignition, the two indicator lights light up briefly.
- ▶ If the system is OK, both of the indicator lights go out.

- ▶ One of the indicator lights then lights up again depending on the position of the key switch:

OFF lights up - front passenger airbag switched off

ON lights up 65 secs after the ignition is switched on - passenger front airbag switched on

Troubleshooting

Key switch for airbag deactivation is faulty

ON flashes together with **OFF** . The front passenger airbag will not be deployed in the event of an accident!

- › Have the airbag system checked by a specialist garage immediately.

Lighting, windscreen wipers and washers

Exterior lighting

Functionality

Unless otherwise stated, the light works when the ignition is switched on.

Daylight running lights

The daytime running lights illuminate the area in front of the vehicle.

In vehicles for certain markets, this also provides lighting for the rear area of the vehicle.

Operating conditions

- ✓ The lights switch is in position **0**, **AUTO** or .

Switching the low beam on/off automatically

The low beam is automatically switched on or off depending on the lighting conditions.

Operating conditions

- ✓ The light switch is in the **AUTO** position.

The automatic headlight circuit is indicated by the illumination of the symbol in the light switch.

Switching low beam on automatically in rain

Operating conditions

- ✓ The light switch is in the **AUTO** position.
- ✓ The function is activated.
- ✓ The windscreen wipers are switched on for longer than 30 seconds.

The automatic headlight circuit is indicated by the illumination of the symbol in the light switch.

Full LED Headlights

When the light switch is in position **AUTO**, the headlights provide the best possible beam of light in front of the vehicle. The **Dynamic cornering light** function ensures the best possible illumination of the curve area.

CORNER function

The CORNER function is intended for turning or manoeuvring (e.g. when parking).

The function illuminates the vicinity of the vehicle front in the direction of travel.

Operating conditions

- ✓ The turn signal is switched on or the front wheels are steered sharply.
- ✓ The low beam is switched on.
- ✓ The fog lights are not switched on.
- ✓ The driving speed is lower than 40 km/h.

When no light is switched on

The symbol in the light switch may also light up in the instrument cluster, indicating that it is necessary to switch on the light.

 illuminates
 > Switch on the light.

Operation

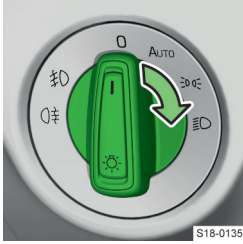

- 0 Switching off the lights except the daytime running lights
- AUTO Switching the low beam on/off automatically
- ☾ Switching on the parking lights
- ☾ Switching on the low beam

[i] As the basic position of the light switch, use position **AUTO**.

High beam and headlight flasher

The high beam works when the low beam is on.

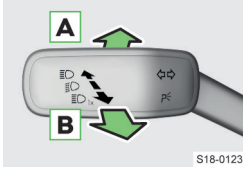

- A Switch on high beam
- B Switch off main beam / switch on headlight flasher

When the main beam or headlight flasher is switched on, the indicator lamp lights up in the instrument cluster .

When the main beam or headlight flasher is switched on, the indicator lamp lights up in the instrument cluster .



CAUTION

Risk of an accident!

> Do not dazzle other road users with the high beam.

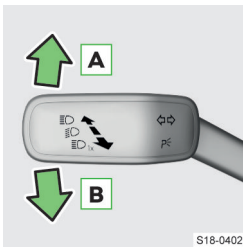
Turn signal



- A Switching on the turn signal light on the right - the warning light flashes in the instrument cluster 
- B Switching on the turn signal light on the left - the warning light flashes in the instrument cluster 

ter 

Turn signal - convenience signalling

Convenience signalling enables three flashes of the turn signal lights without having to move the lever up or down.

> Tap the control lever up or down.



The corresponding turn signal lights flash three times.

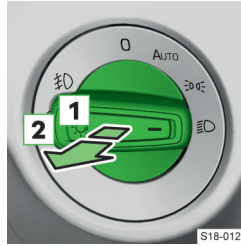

Tap the lever in the opposite direction ahead of time to stop signalling.

Fog light



Positions for pulling out the light switch

- 1 Fog lights - when switched on, the indicator light in the instrument cluster illuminates 
- 2 Rear fog light - when switched on, the indicator light in the instrument cluster illuminates 

- > Turn the light switch to position **AUTO**,  or .
- > Pull the light switch to the appropriate position.

[i] The rear fog light does not illuminate when an accessory is connected to the trailer socket.

Hazard warning light system

> Press the button to switch on or off  in the middle part of the control panel.

The hazard warning lights can be switched on automatically during hard braking. The hazard warning lights are then switched off again automatically when starting off or accelerating.

[i] When the hazard warning system is on and the turn signal is switched on, the hazard warning lights will be switched off temporarily and only the turn signal will flash on the relevant side of the vehicle.

One-sided parking light p<

The one-sided parking light allows one side of the parked vehicle to be illuminated through activation of the corresponding sidelights.

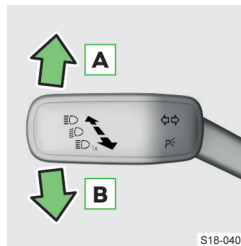

- A Switch on the sidelights on the right
- B Switch on the sidelights on the left

- > Switch off the ignition.
- > Move the lever to the appropriate position.
- > Lock the vehicle.

When the parking light is switched on, an acoustic

warning signal sounds and the driver's door is opened. After a few seconds or after the driver's door is closed, the warning signal will stop.

Double-sided parking light >><

The two-sided parking light allows the parked vehicle to be illuminated through activation of the sidelights.

> Turn on the ignition.

- › Turn the light switch to position .
- › Switch off the ignition.
- › Lock the vehicle.

When the parking light is switched on, an acoustic warning signal sounds after the ignition is switched off and the driver's door is opened. After a few seconds or after the driver's door is closed, the warning signal will stop.

The light may switch off automatically if the 12-volt vehicle battery is too low. If the parking lights on both sides are switched on with the ignition off, the lights will not be switched off automatically and the 12 volt vehicle battery may be discharged.

Settings

Activating/deactivating the automatic headlights system in rain

The function is activated or deactivated in the following menu in the Infotainment system:

CAR >  > 

Or:

MENU >  >  > 

Activating/deactivating convenience signalling

The function is activated or deactivated in the following menu in the Infotainment system:

CAR >  > 

Or:

MENU >  >  > 

Headlight range control of the Halogen headlights

- › In Infotainment, select the following menu:

CAR >  > 

Or:

MENU >  >  > 

- › Adjust the headlight range using the slider. The headlight range must correspond to the vehicle's load.

- 0 Front seats occupied, boot empty
- 2 All seats occupied, boot empty
- 4 All seats occupied, boot loaded
- 6 Driver's seat occupied, boot loaded

In the event of another vehicle loading condition, the positions **1**, **3**, **5** can be used.

 For the Full LED headlights, the headlight range control is adjusted automatically.

WARNING

Risk of an accident!

An incorrectly adjusted headlight range can cause insufficient vehicle lighting or can dazzle other road users.

- ▶ Adjust the headlight range correctly.

Adjust headlights for driving in right / left-hand traffic

Applies to full LED headlights.

- › In Infotainment, select the following menu:

CAR >  > 

Or:

MENU >  >  > 

- › Activate the travel mode function.

Troubleshooting

Turn signal light defective

 flashes faster - turn signal light on the right defective

- › Check the turn signal light on the right.

 flashes faster - turn signal light on the left defective

- › Check the turn signal light on the left.

 does not flash when the trailer is hitched - trailer turn signal light defective

- › Check the trailer lighting.

Light bulb or LED bulb is defective

 or  illuminates

Information appears in the display regarding the defective lights.

- › Replace the defective bulb.
- › In case of a defective LED bulb, contact a specialist garage for help.

The headlights are misted up on the inside

Inside the headlights, moisture may occur. This is not a defect.

Malfunction of the automatic headlight circuit

- › Clean the windscreen in the area of the rain/light sensor.

Beam of light in front of the vehicle has shortened

Headlight defective.

- › Seek the help of a specialist garage.

Driving lights defective

If a message regarding the failed driving lights is displayed, the light will work in emergency mode.

- › Drive on, exercising appropriate caution.
- › Seek the help of a specialist garage.

COMING HOME, LEAVING HOME exterior lighting

Functionality

The COMING HOME function turns on the light after turning off the ignition and opening the driver's door. The light switches off automatically after the set lighting time has elapsed.

The LEAVING HOME function switches on the light when unlocking the vehicle with the wireless remote control.

Operating conditions

- ✓ Visibility has worsened.
- ✓ The light switch is in the **AUTO** position.

Settings

This function is set in the following menu in the Infotainment system:

CAR >  > 

Or:

MENU >  >  > 

Light Assist high-beam assist system

Functionality

The high beam assist system automatically switches the high beam on and off.

⚠ WARNING
Risk of accident!

- ▶ If necessary, manually switch the high beam on or off.

Operating conditions

- ✓ The system is activated.
- ✓ The light switch is in the **AUTO** position.
- ✓ The driving speed is higher than 30 km/h or 60 km/h (depending on the vehicle equipment).
- ✓ The low beam is switched on.

Operation

Switching on

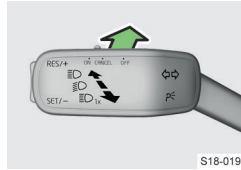

- ▶ Push the lever in the direction of the arrow.
- It lights up in the instrument cluster  from the isolation box.

Switching off

- ▶ Manually switch the high beam on or off.

Function restriction

The system may dazzle other road users if their headlights/lights are not detected for the following reasons, for example:

- ▶ The headlights/lights of oncoming vehicles are covered by crash barriers, for example.
- ▶ The headlamps/lights of the oncoming or preceding vehicle are dirty or not functioning.

Settings

Activation/deactivation

The function is activated or deactivated in the following menu in the Infotainment system:

CAR >  > 

Or:

MENU >  >  > 

Replace light bulbs

What you should be mindful of

DIY replacement of the following bulbs is possible. Have the remaining light sources replaced by a specialist garage.

The new bulb must conform to the specification of the original light bulb. The name of the bulb is marked on the bulb socket.

After changing a bulb in the low beam light, the main beam or fog light, have the headlights adjusted by a specialist garage.

⚠ CAUTION

Halogen lamps are pressurised and can burst during replacement!

- ▶ Wear gloves and safety goggles.

ⓘ NOTICE

Contamination of the halogen lamp reduces the life of the lamp!

- ▶ Do not touch the glass of the light bulb with your bare fingers.

ⓘ NOTICE

Danger of headlight damage due to the ingress of water and dirt!

- ▶ Always fit the protective cap on the headlight correctly after changing a bulb.

Conditions for changing a bulb

- ✓ Ignition off
- ✓ Light switched off

Low beam and high beam

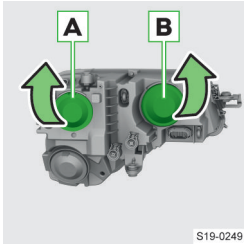

S19-0249

Protective caps on the headlight:

- A** Low beam
- B** Main beam

- › Remove the associated protective cap.

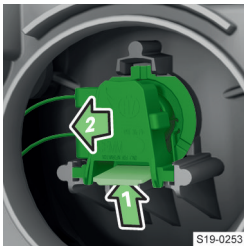

S19-0253

- › Press the locking lug and remove the base with the bulb.
- › Change the bulb in the socket.

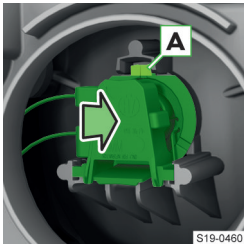

S19-0460

- › Insert the socket with the new light bulb into the headlight, so that the fixing lug **A** is pointing up.
- › Insert the socket until it clicks into place.
- › Fit the protective cap on the headlight again.

Front parking light

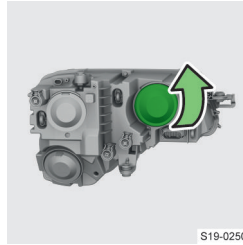

S19-0250

- › Remove the protective cap from the headlight.



S19-0256

- › Press the locking lugs and remove the base with the bulb.

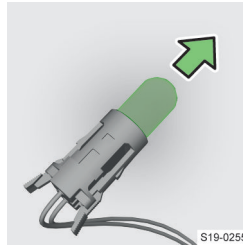

S19-0255

- › Change the bulb in the socket.
- › Insert the socket with the bulb into the headlight until the locking lugs engage.
- › Fit the protective cap on the headlight again.

Front turn signal

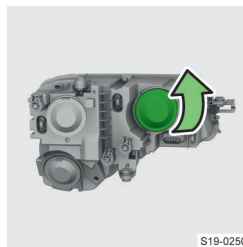

S19-0250

- › Remove the protective cap from the headlight.

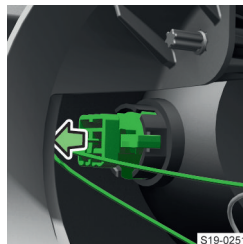

S19-0251

- › Remove the base with the bulb.

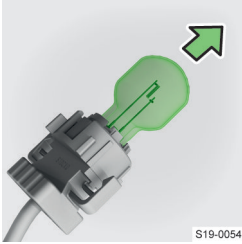

- › Change the bulb in the socket.



- › Turn the bulb and remove it.

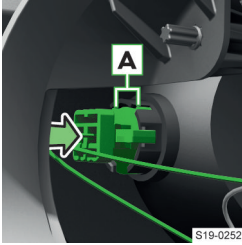

- › Insert the socket with the light bulb into the light so that the fixing lugs **A** fit into the recesses on the headlight.
- › Fit the protective cap on the headlight again.

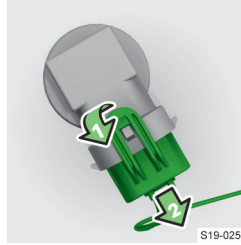

- › Release the connector and remove it from the bulb.

Fog lights

Removing the cover cap from the wheel housing

- › Adjust the front wheels so that the cover cap is accessible.

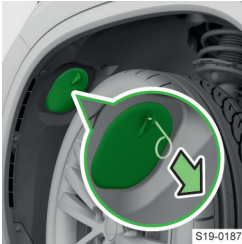

- › Insert the bracket from the tool kit into the recess in the cover cap.
- › Remove the cover by pulling on the bracket.

Removing the defective light bulb



- › Remove the rubber protective cap from the headlight.

Inserting a new bulb and cover cap in the wheel arch

- › Insert the plug into the new bulb until it clicks into place.
- › Insert the new bulb into the headlight so that the guide lugs on the bulb are aligned with the corresponding openings in the headlight.
- › Turn the bulb clockwise ↻ to secure.
- › Replace the rubber protective cap on the headlight.
- › Insert the cover in the wheel arch and lock into place.

Rear turn signal and reversing lights

Loosen and remove the light

- › Open the relevant cover in the luggage compartment.

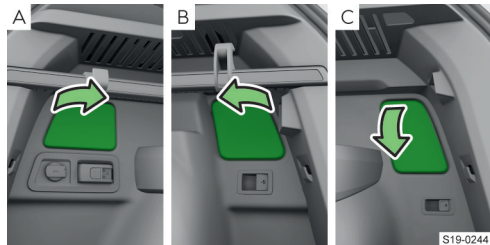

- A** Cover on the left
- B** Cover on the right - vehicle with standard rear seats
- C** Cover on the right - vehicle with VarioFlex rear seats



› Unscrew the screw.

› Make sure that no cables are trapped when inserting the holder into the lamp.

Insert and fix the light

› Insert the connector into the light until it clicks into place.

› Push in the slightly pulled out locking device on the plug.



› Remove the light.

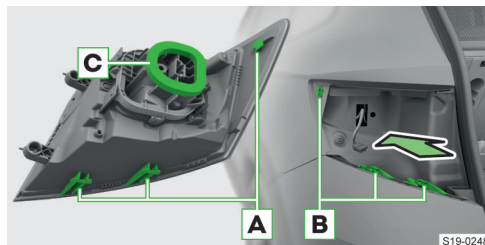

› Insert the lamp with the strips **A** into the grooves **B** in the bodywork and push in carefully until it stops.

ⓘ **NOTICE**

Risk of damage to the electrical system due to water ingress!

› Make sure that the seal is used correctly when installing the lamp **C**.

ⓘ **NOTICE**

Risk of damage to the electrical system!

› Make sure that the lines between the lamp and the body are not pinched when the lamp is inserted.

› Screw the light into place.

› Close and lock the cap.

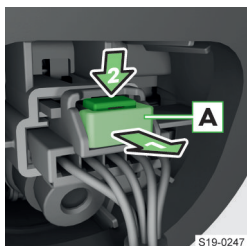

› Slightly pull out the lock **A** at the plug.

› Press the safety button and remove the plug.

Replacing the light bulb

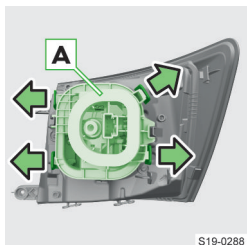

› Unlock and remove the lamp holder **A**.

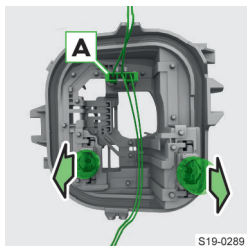

› Change the bulb in the socket.

› The base for the bulb in the turn signal light is marked with **YELLOW**.

The base for the bulb in the reverse light is marked with **CLEAR**.

› Check that the plug **A** securely connected.

› Insert the bulb holder into the light and snap into place.

ⓘ **NOTICE**

Risk of damage to the electrical system!

Interior lighting

Operation

Operation of the lighting

- ☰ Switching on
 - ☰ REAR Rear lighting
 - 0 Switching off
 - ☰ Reading lamp left
 - ☰ Reading lamp right
 - ☰ Automatically switch on and switch off
- The switch without the ☰ symbol is the middle position of the switch

Switching on automatically

The lighting switches on when one of the following events occurs.

- › The vehicle is unlocked
- › One of the doors is opened
- › The ignition key is removed (vehicle without start-button)

Automatic switch off

The lighting switches off when one of the following events occurs:

- ▶ The vehicle is locked
- ▶ The ignition is switched on
- ▶ About 30 seconds after all the doors have been closed

I If a door remains open and the ignition is switched off, the lights will turn off automatically after 10 minutes.

Automatic switching on/off of the footwell lighting

The lighting only works when the dipped or parking lights are on.

The lighting is also switched on automatically after opening the door (e.g. when getting in or out).

Turn on the lighting for the make-up mirror in the sun visors on the windscreen

- › Slide off the cover of the make-up mirror.

Settings

The brightness level of the footwell lighting is set in the Infotainment in the following menu when the low beam or parking light is switched on:

CAR > > >

Or:

MENU > > >

Interior ambient light

Usage

The ambient lighting ensures a comfortable atmosphere in the vehicle interior.

The lighting only works when the dipped or parking lights are on.

The lighting is also switched on automatically after opening the door.

Settings

The background lighting brightness settings are set in the Infotainment system, in the following menu:

CAR > > >

Or:

MENU > > >

Windscreen wipers and washers

Operating conditions

- ✓ Engine compartment flap closed
- ✓ Boot lid closed
- ✓ Ignition on

Operation

⚠ WARNING

Risk of an accident!

At low temperatures, windscreen washer fluid can freeze on the windscreen and restrict visibility.

- ▶ Only use the windscreen washer when the windscreen is warm.

Wipe and wash the windscreen

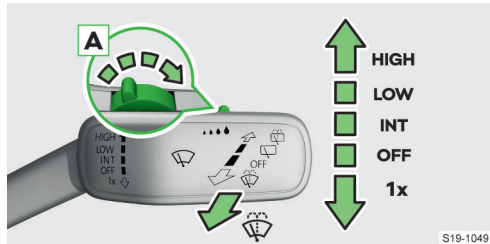

HIGH Fast wiping

LOW Slow wiping

INT Depending upon vehicle equipment:
 ▶ Intermittent wiping
 ▶ Automatic wiping controlled by the rain sensor

OFF Switching off

1x Tip-wiping (spring-loaded position)

A Setting the wiping speed for the position INT

Washing and wiping (spring-loaded position)

Depending on the vehicle equipment, the windscreen washer nozzles of the windscreen can be heated automatically.

Clean headlights

When the headlights are switched on, they are cleaned the first time and after every tenth wash of the windscreen. Setting the spray interval can be carried out by a specialist garage.

Wipe and wash the rear window

S19-1050

- ☰ Spring-loaded position:
 - ▶ Washing and wiping the windscreen
 - ▶ Cleaning the rear view camera

☰ Wiping

OFF Switching off

Automatic rear window wiping

If the windscreen wiping is performed without interruption, then the automatic regular intermittent wiping of the rear window takes place.

When the windscreen wipers are switched on, the rear window is automatically wiped when the reverse gear is engaged.

Settings**Activating/deactivating automatic wiping**

The functions for automatic rear window wiping and automatic wiping in the rain can be activated and deactivated in the following menu in the Infotainment system:

CAR > ☰ > ☰

Or:

MENU > 🚗 > ☰ > ☰

Refilling windscreen washer fluid**⚠ WARNING**

Risk of an accident!

- ▶ Use windscreen washer fluid that is suitable for the weather conditions.

ⓘ NOTICE

Risk of damage to the windscreen washer system!

- ▶ When refilling the washer fluid, do not remove the strainer from the neck of the container.

ⓘ NOTICE

Risk of damage to the headlights!

- ▶ Only use washer fluid that does not attack polycarbonates.

ⓘ NOTICE

Risk of damage to engine compartment components!

- ▶ Close the container after refilling the windscreen washer fluid.

The windscreen washer tank is located in the engine compartment » page 12.

The container can hold a volume of 5 litres or 3 litres and 5 litres for vehicles with a headlight cleaning system depending on the engine type.

- › Open the engine compartment lid » page 198.
- › Gently open the top of the sealing cap.
- › Top up the windscreen washer fluid.
- › Close the sealing cap of the tank.

Troubleshooting**Windscreen washer fluid level too low**

☰ illuminates together with ⚠

or

☰ illuminates together with ⚠

- › Top up the windscreen washer fluid.

Frozen windscreen wipers

- › Carefully remove frozen windscreen wipers from the windscreen before switching on the ignition and free them from snow and ice.

Folding down windscreen wiper arms and replacing windscreen wiper blades

For folding down the windscreen wiper from the screen you must first adjust the wiper arms to the folded position.

ⓘ NOTICE

Risk of damage to the windscreen wipers and the engine compartment lid!

- ▶ Close the bonnet before lowering the wiper arms from the window.
- ▶ Do not turn on the ignition when the windscreen wiper arms are folded away.

Set the windscreen wiper arms into the folding position

- › Switch the ignition on and off again.

- › Within 10 seconds, press the control lever down and hold for about 2 seconds.

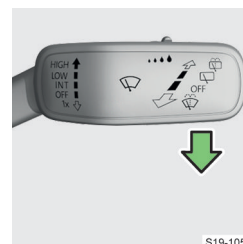

S19-1051

Replace the windscreen wiper blade

⚠ CAUTION

Risk of accident!

- ▶ Change the windscreen wiper blades once or twice a year.
- › Fold the windscreen wiper arm away from the windscreen.

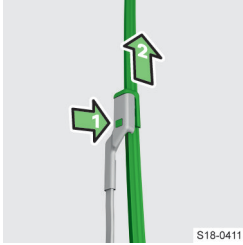

- › Press the catch and remove the wiper blade.
- › Insert the new wiper blade until it clicks into place.
- › Fold the windscreen wiper arm back onto the windscreen.
- › Turn on the ignition and push the control lever down.

Heating and air conditioning system

Manual air conditioning

What you should be mindful of

- ▶ We recommend keeping the interior temperature no more than 5 °C lower than the outdoor temperature.
- ▶ We recommend switching the cooling system off about 10 minutes before the end of the journey to prevent odour formation.
- ▶ Annual disinfection of the air conditioning is recommended.

⚠ WARNING

Danger of misting!

- ▶ Always keep the fan on.

⚠ WARNING

Risk of accident!

In recirculation mode, there is no fresh air supply from the outside. This can result in loss of driver attention and fogging up of windows.

- ▶ Keep the recirculation mode switched on for a short time only.

Operating conditions for the cooling system

- ✓ Outside temperature above 2 °C
- ✓ Running engine
- ✓ Fan switched on

Overview of the controls for the manual air conditioning

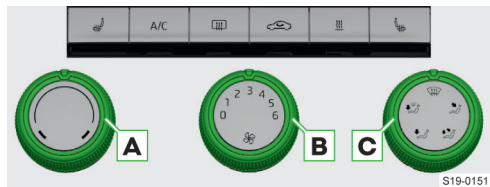

A Set the temperature

B Set the blower speed

C Set the direction of the air outlet

Switch the seat heating on/off » page 63, Operation

A/C Switch the cooling system on/off

Switch on/off the windscreen heating » page 63, Operation

Switch recirculated air mode on/off

- ☰ Switch auxiliary heating and ventilation on/off » page 61, Usage

Cooling system



When the cooling system is switched on, the temperature and humidity in the vehicle will drop.

Switching on the cooling system prevents the windows from misting up.

I After pressing the **A/C** button, the indicator light in the button illuminates, even if the conditions for switching on the cooling system are not met. The cooling system switches on when the conditions for switching on the cooling system are met.

Automatic activation of the cooling system

Automatic activation of the cooling system prevents the windows from misting up. The system switches on in the following cases.

- ▶ When the fan is on and the air distribution controller is in the  position.
In this case, the recirculation mode is switched off.
- ▶ When the air distribution controller is not in the  position, and recirculated air mode is switched on.

Recirculated air mode

The recirculation mode prevents contaminated outside air getting into the interior of the vehicle.

Briefly switching on recirculation mode can increase the cooling effect.

I Under certain circumstances, the recirculation mode may be switched on or off automatically.

I When the air conditioner is operating, the engine idle speed may increase automatically.

Troubleshooting

Water under the vehicle

When the cooling system is switched on, water can drip off the air conditioning system. This is not a leak.

Fogging

- ▶ Increase the blower speed, switch on the cooling system, and set the air distribution to the wind-screen.

Automatic switch-off of the cooling system

If the coolant temperature is too high, the cooling system may switch off automatically. This ensures sufficient engine cooling.

Climatronic automatic air conditioning system

What you should be mindful of

- ▶ We recommend keeping the interior temperature no more than 5 °C lower than the outdoor temperature.
- ▶ We recommend switching the cooling system off about 10 minutes before the end of the journey to prevent odour formation.
- ▶ Annual disinfection of the air conditioning is recommended.

⚠ WARNING

Danger of misting!

- ▶ Always keep the fan on.

⚠ WARNING

Risk of accident!

In recirculation mode, there is no fresh air supply from the outside. This can result in loss of driver attention and fogging up of windows.

- ▶ Keep the recirculation mode switched on for a short time only.



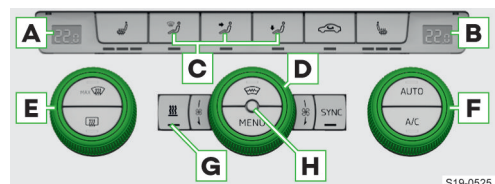

Operating conditions for the cooling system

- ✓ Outside temperature above 2 °C
- ✓ Running engine
- ✓ Fan switched on

Operation



- A** Set the temperature for the left side
- B** Set the temperature for the right side
- C** Set the direction of the air outlet
- D** Set the blower speed
- E** Set the temperature for the left side
- F** Set the temperature for the right side
- G** Depending on the equipment:
 - ▶ ☰ Switch auxiliary heating and ventilation on/off » page 61, Usage
 - ▶ **OFF** Switching Climatronic system off
- H** Interior temperature sensor

-  Switch the seat heating on/off » page 63, *Operation*
-  Switch recirculated air mode on/off
The recirculation mode prevents contaminated outside air getting into the interior of the vehicle.
-  Switch the windscreen ventilation/defrosting mode on/off
-  Switch on/off the windscreen heating » page 63, *Operation*
-  Switch on/off the windscreen heating » page 63, *Operation*
- MENU** Operate Climatronic in the Infotainment system
- SYNC** Switch maintenance of the interior temperature on/off according to the temperature setting for the driver's side
- AUTO Press** - Switch on automatic mode
This function keeps the temperature constant and prevents the windows from misting.
- Hold** - Maintain the interior temperature in accordance with the temperature setting for the driver side (SYNC function)
- A/C** Switch the cooling system on/off
When the cooling system is switched on, the temperature and humidity in the vehicle will drop.
Switching on the cooling system prevents the windows from misting up.

 The rear temperature can also be set on the display in the centre console at the rear.

With a temperature setting outside of the number range, one of the following icons will be displayed in the Climatronic display:

- LO** Maximum cooling power
- HI** Maximum heating power

 When the air conditioner is operating, the engine idle speed may increase automatically.

Settings

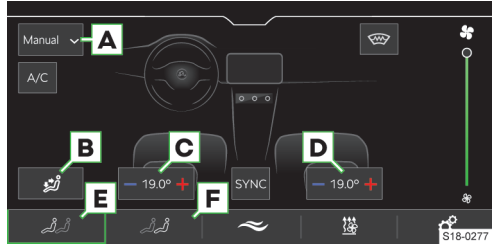

Display the settings menu

- › Tap the **MENU** button on the Climatronic.
- Or:
- › Tap on **MENU** ›  in the Infotainment screen.



- A** Select Climatronic mode
- B** Set the direction of the air outlet in manual mode
- C** Set the temperature for the left side
- D** Set the temperature for the right side
- E** Show the front settings menu
- F** Show the back settings menu

- A/C** Switch the cooling system on/off
When the cooling system is switched on, the temperature and humidity in the vehicle will drop.
Switching on the cooling system prevents the windows from misting up.

-  Switching the windscreen heater on/off » page 63, *Operation*
-  According to the selected Climatronic mode:
 - ▶ Manual mode - Set the blower speed
 - ▶ Automatic mode - Set the operating power

- SYNC** Switch maintenance of the interior temperature on/off according to the temperature setting for the driver's side

-  The Air Care function reduces the penetration of pollutants into the vehicle interior. At the same time, the air is both circulated and cleaned.

The air purification process is displayed in the Infotainment.

For proper operation, the doors and windows must be closed.

- › To switch on/off Active .

-  Switch auxiliary heating and ventilation on/off » page 61, *Usage*

-  Lock increases in heat output for the rear seat heater » page 63, *Operation*
The function is displayed after tapping the function surface **F**.

Further Climatronic settings

- › To make further settings, press the **MENU** button on the Climatronic ›, tap on  in the Infotainment screen.

- ▶ *Automatic air recirculation* - Automatic air circulation mode on/off
- ▶ *Automatic supplementary heater* - Switch fast interior heating on/off
- ▶ *Automatic windscreen heating* - Switch on/off the automatic windscreen heating

Troubleshooting

Water under the vehicle

When the cooling system is switched on, water can drip off the air conditioning system. This is not a leak.

Fogging

- › Switch on automatic mode.

Or:

- › Increase the blower speed, switch on the cooling system, and set the air distribution to the windscreen.

Automatic switch-off of the cooling system

If the coolant temperature is too high, the cooling system may switch off automatically. This ensures sufficient engine cooling.

Auxiliary heating and ventilation

Usage

The auxiliary heater heats the vehicle interior and the engine.

The auxiliary ventilation makes it possible to supply fresh air to the vehicle interior when the engine is switched off. As a result, the interior temperature is lowered, e.g. when the vehicle is parked in the sun.

What you should be mindful of

⚠ DANGER

Risk of poisoning!

- ▶ The auxiliary heater must not be operated in enclosed spaces.

⚠ DANGER

Risk of fire!

- ▶ Switch off the auxiliary heater before refuelling.
- ▶ The exhaust pipe for the auxiliary heater is located on the underside of the vehicle. Therefore, do not stop the vehicle in places where the exhaust gases could come into contact with easily flammable materials, e.g. dry grass, spilled fuel etc.

Functionality

The system heats or ventilates the vehicle interior depending on the temperature settings of the air

conditioning system and the air outlet nozzles before the ignition is switched off.

The system consumes fuel from the fuel tank when operating the heating.

Operating conditions

- ✓ The charge state of the 12-volt vehicle battery is sufficient.
- ✓ The fuel supply is sufficient, the instrument cluster does not light up .

Operation

Switch on/off with the radio remote control

- › Hold down the corresponding key.

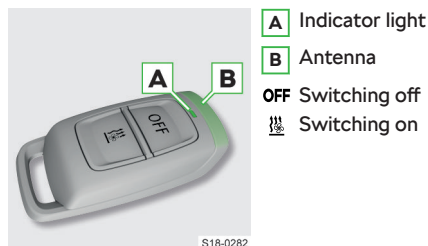

 Hold the radio remote control with the antenna facing upwards.

ⓘ NOTICE

- ▶ Protect the remote control from moisture, strong vibrations and direct sunlight.

Display of the radio remote control indicator light

- ▶ Lit up green for 2 seconds - switch on
- ▶ Lit up red for 2 seconds - switch off

Range of the radio remote control

The range of the wireless remote control is a few hundred meters when the battery is full. For example, obstacles or weather conditions can reduce the range.

Switching on/off via the control panel of the air conditioning system

- › Press the  button.



Set automatic switching on

Show the menu for vehicles with manual air conditioning

The automatic switching on is set in the following menu in the Infotainment system.

CAR > 

Or:

MENU >  > 

Show menu for vehicles with Climatronic

› Press the button **MENU** on the Climatronic control panel ›, tap  in the Infotainment screen.

Settings and information in the Infotainment screen

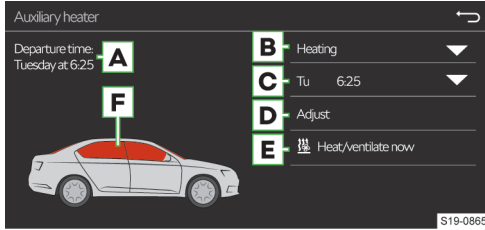

- A** Day and time when the vehicle is to be ready for use
- B** Setting the heating/ventilation
- C** List of pre-selected times, activation / deactivation of the preset time
- D** Set the selected choice of time and the duration (10-60 minutes)
- E** Immediate switch-on
- F** When the heating is running, the windows are displayed in red
When ventilation is running, the windows are displayed in blue

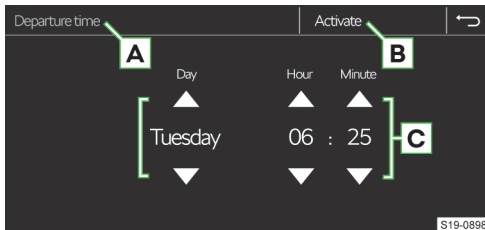

- A** Currently displayed preset time
- B** Activation of the currently displayed preset time
- C** Setting the departure time

When automatic switching on is activated, the warning light in the  button lights up after the ignition is turned off.

Only one preset time can be active. The activated preset time will be deactivated again after it has started automatically. To start the next preset time, this preset time must be activated.

i When selecting the day in the preset time, there is an option between Sunday and Monday without the specified day. When this position is selected, the system is switched on at the next set time.

Troubleshooting

Smoke in the engine compartment

In the engine compartment, smoke and odours may form during the operation of the auxiliary heater. This is not a defect.

Running the auxiliary heater after stopping the engine

After switching off the system, the coolant pump and the auxiliary heating will continue running a little while longer in order to burn the remaining fuel in the heating.

Indicator light in the radio remote control

- › Flashes green in a slow sequence - the switch-on signal was not received
- › Flashes red in a slow sequence - the switch-off signal was not received
- › Flashes green in an irregular pattern – the parking heater is locked, e.g. because the fuel tank is almost empty or there is an error
- › Check the level of fuel.
- › If the fuel quantity is OK, seek the help of a specialist company.
- › Lights up orange first, then green/red – the battery is weak, the on/off signal has been received
- › Lights up orange first, then flashes green/red – the battery is weak, the on/off signal has not been received.
- › Flashing orange – the battery is nearly discharged, the on/off signal has not been received
- › Not lit up – the battery is discharged, the on/off signal has not been received
- › Replace the battery.

Change the battery in the remote control

⚠ WARNING

Risk of death!

If the battery is swallowed, serious or even fatal injuries can result from burns in the digestive tract.

- › Always keep children away from the radio remote control and batteries.
- › If the battery is swallowed, seek medical help immediately.

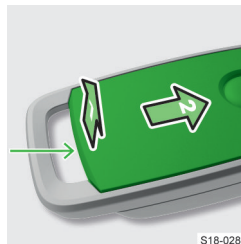

- › Use a thin screwdriver to remove the cover in the marked area.
- › Open the cover and push it out.

S18-0280

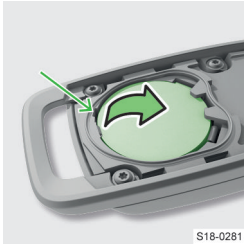

- › Use a screwdriver to loosen the battery in the marked area.
- › Replace the battery.
- › Insert the cover and push it until it audibly locks into place.

Heated windscreen

Usage

Windscreen heating is used for defrosting or ventilating the windscreen.

Requirements

- ✓ Running engine
- ✓ Outside temperature approximately below 35 °C

Operation

Heated rear window

- › Press the button.

Heated windscreen

- › Tap the button on the Climatronic.

Or:

- › Press the key **MENU** on the Climatronic › , tap in the Infotainment screen.

Windscreen heating switches off automatically after some time.

If the engine is switched off when the heating is on and turned back on again within about 10 minutes, the heating is continued.

Settings

Automatic heated windscreen

The heated windscreen switches on automatically if the windscreen mists up.

- › Press the button **MENU** on the Climatronic control panel ›, tap in the Infotainment screen.

Or:

- › Tap on **MENU** › › in the Infotainment screen.

Troubleshooting

The indicator light in the button or below the button flashes

The heating does not work as the battery charging level of the 12 volt vehicle battery is too low.

Seat heating

What you should be mindful of

⚠ WARNING

Risk of burns!

- ▶ Do not switch on the seat heater for persons with limited perception of pain or temperature.

ⓘ NOTICE

Risk of seat damage!

- ▶ Do not kneel on the seats or otherwise apply concentrated pressure to them.
- ▶ Do not turn on the heater in the following situations:
 - ▶ The seat is not occupied.
 - ▶ There are objects on the seat, such as a child seat.
 - ▶ There are additional seat covers or protective covers on the seat.

Requirements

- ✓ Running engine

Operation

- › Press the or button on the Climatronic to switch on the front seat heating.
- › Press the or button in the rear centre console to switch on the rear seat heating.

The heating is switched on with maximum heating output. By repeatedly pressing the button, the heating output is reduced until it is switched off.

The output level of the heating is indicated by the number of illuminated indicator lights in the button or in the Infotainment screen.

Settings

Lock increases in heat output for the rear seat heater

- › To turn the function on or off, press the **MENU** button on the Climatronic › /REAR in the Infotainment screen.

Or:

- › Tap on **MENU** › › /REAR in the Infotainment screen.

When the function is switched on, the heating output can only be turned down.

i The function also blocks the possibility of setting the temperature in the display in the rear centre console.

Heated steering wheel

Requirements

- ✓ Running engine

Operation

- › Press the  button on the multifunction steering wheel.

The heating is switched on with maximum heating output. By repeatedly pressing the button, the heating output is reduced until it is switched off.

Driver information system

Analogue instrument cluster

Overview

Overview of instrument cluster

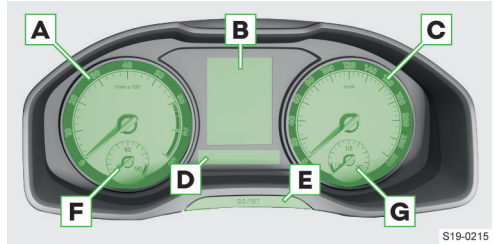

- A** Tachometer with indicator lights
- B** Display
- C** Speedometer with indicator lights
- D** Bar with indicator lights
- E** Multifunction button:
 - ▶ Setting the time
 - ▶ Reset odometer (trip)
 - ▶ Show distance and days until next service appointment
- F** Coolant temperature gauge
- G** Fuel gauge

i NOTICE

Risk of serious damage to the engine and the exhaust system!

- ▶ **Never run the fuel tank completely empty!**

i In poor visibility and with dipped headlights off, the brightness of the instrument cluster lighting is reduced to remind the driver to turn on the light.

Display overview

Depending on the equipment, the following information is shown in the display.

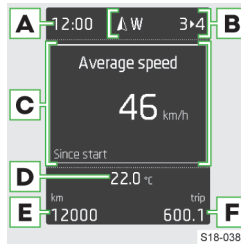

- A** 12:00 **A** W 3x4 **B** **A** Time
- C** Average speed 46 km/h **B** Selected gear/gear recommendation
Also included depending on vehicle equipment:
 - ▶ Compass direction display
 - ▶ Automatic gearbox selector lever positions
- D** Since start 22.0 °C
- E** km 12000 **F** trip 600.1

- C** Menu, indicator lights and information
 - ▶ Detected road signs

- D** Outside temperature
❄ or ❄ - low outside temperature
- E** Total distance travelled
- F** Trip - Distance travelled after resetting the memory

Overview of the main menu items

- ▶ Driving data » page 67, *Overview*
- ▶ Assist systems - Activate/deactivate assist systems
- ▶ Navigation - e.g. Display driving recommendations, compass, list of destination
- ▶ Audio - Using radio and media
- ▶ Telephone - Call list, accept or reject an incoming call
- ▶ Vehicle - Vehicle condition » page 68, *Display*.
- ▶ Lap timer - Stopwatch » page 68, *Usage*.

Operation

Operation via the multifunction steering wheel

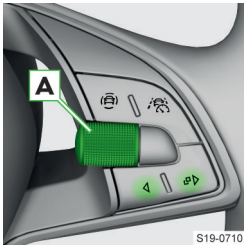

- A** Turn - Switch between menu items/set values
- Press** - Confirm the menu item
- ◀ **Press** - Return to the menu one level higher
- Hold** - Show main menu

▶ **Press** - Show previous menu (if one has been selected) / Show telephone menu

Settings

Setting the language

The language is set in the Infotainment in menu **MENU** > ⚙.

Resetting the odometer



▶ Briefly press the button in the instrument cluster.

Setting the time



▶ Press and hold the button in the instrument cluster until the menu item *Time* is displayed.

- ▶ Release the button, the display shows the hour setting.
- ▶ Press the button repeatedly to set the hours.
- ▶ Wait 4 seconds, the display shows the minute setting.
- ▶ Press the key repeatedly to set the minutes.

▶ Wait 4 seconds, the display shows the initial setting.

The time is also set in the Infotainment in menu **MENU** > ⚙.

Setting the brightness of the instrument cluster lighting

The brightness of the instrument lighting is adjusted automatically according to the given lighting conditions.

When low beam is switched on, the brightness of the instruments lighting can be adjusted in the following menu in the Infotainment system:

CAR > ⚙ > ☀

Or:

MENU > 🚗 > ⚙ > ☀

Digital instrument cluster

Overview

Overview of instrument cluster

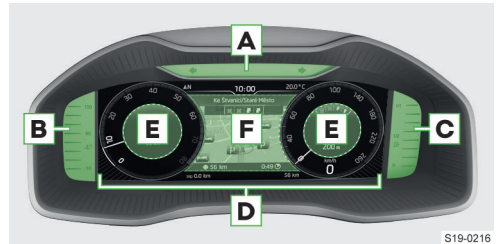

- A** Bar with indicator lights
- B** Coolant temperature gauge
- C** Fuel gauge
- D** Display
- E** Additional information
- F** Central display area

⚠ NOTICE

Risk of serious damage to the engine and the exhaust system!

▶ **Never run the fuel tank completely empty!**

Overview of the main menu items

- ▶ Driving data » page 67, *Overview*
- ▶ Assist systems - Activate/deactivate assist systems
- ▶ Navigation - e.g. Display driving recommendations, compass, list of destination
- ▶ Audio - Using radio and media
- ▶ Telephone - Call list, accept or reject an incoming call
- ▶ Vehicle - Vehicle condition » page 68, *Display*.

▶ Lap timer - Stopwatch » page 68, Usage.

Operation

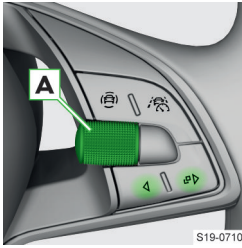

- A** **Rotate** - Switch between menu items/Set values/Manually change map scale
- Press** - Confirm the menu item
- Turn and press** - Activate automatic map scale changing

Press - Return to the menu one level higher

Hold - Show main menu

⌂ **Press** - Change the variant of the display

Hold - Display the menu of preset options with additional information

Settings

Setting the language

The language is set in the Infotainment in menu **MENU** > ⚙️.

Resetting the odometer in the instrument cluster

▶ Select *Trip* in the menu in instrument cluster display.

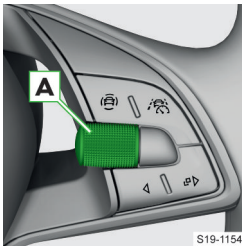

- A** **Turn** - Select information
- Press** - Confirm information
- Hold** - Reset counter

Setting the time

The time is set in the Infotainment in menu **MENU** > ⚙️.

Setting the brightness of the instrument cluster lighting

The brightness is adjusted automatically according to the given lighting conditions.

The brightness is adjusted with the dipped beam switched on in the infotainment in the following menu:

CAR > ⚙️ > ☀️

Or:

MENU > 🏠 > ⚙️ > ☀️

Set the variant of the display

▶ Press the ⌂ button on the multifunction steering wheel to change the variant of the display presentation.

Select displayed variants

- ▶ Press and hold the ⌂ button on the multifunction steering wheel.
- ▶ Select and confirm the menu item for the display variants.
- ▶ Select one of the following variants of the display and confirm.



- A** Classic display
- B** Advanced display
- C** Modern display
- D** Basic display
- E** Sporty display (depending on equipment)

Choose display of additional information

- ▶ Press and hold the ⌂ button on the multifunction steering wheel.
- ▶ Select and confirm one of the following prefix options (the scope of the prefix options depends on the type of Infotainment):
 - ▶ **Auto** - Information depending on the selected driving mode
 - ▶ **Classic** - Information about the selected gear and the current speed
 - ▶ Adjustable pre-selection options.

Setting the pre-selection option for the display of additional information

The pre-selection option for displaying additional information is set in the Infotainment system in the following menu:

CAR > ⚙️ > Menu item for the virtual cockpit

Or:

MENU > 🏠 > ⚙️ > Menu item for the virtual cockpit

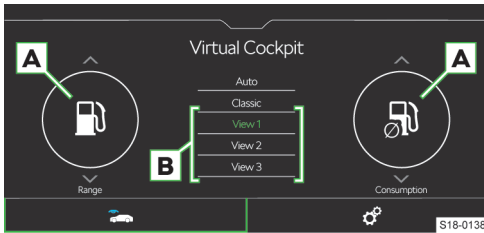

- › Select the desired additional information in the **A** areas.
- › The desired function area for the preselection option in the area **B** hold to save the selection (the scope of the preset options depends on the type of Infotainment).

Driving data

Overview

The driving data display works with the ignition switched on.

In the instrument cluster display

Depending on the equipment, the display of the instrument cluster shows information such as speed, fuel consumption, range, etc.

In Infotainment

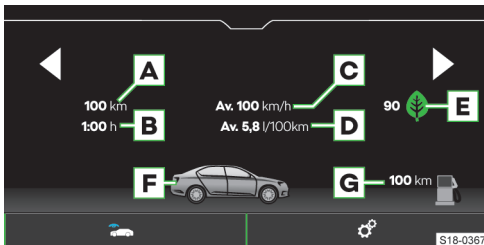

- A** Distance travelled
- B** Driving time
- C** Average speed
- D** Average fuel consumption
- E** Evaluation of driving economy - **Drive-Green**Function (depending on Infotainment type) » page 173
- F** Graphical fuel gauge - If the expected range is less than 300 km, the vehicle slowly approaches the symbol
- G** Range

Memory

The system saves the driving data in the following memories:

Since start

- › Driving data from the time of switching on the ignition until the ignition is switched off again is stored in the memory. If the journey is interrupted for more than 2 hours, the memory will be reset.

Long-term

- › The driving data of all trips up to a total of 99 hours and 59 minutes driving time or 9999 km driving distance is stored in the memory. If one of the listed values is exceeded, the memory is reset.

Since refuel

- › Driving data from the time the fuel tank was last filled is stored in the memory. The memory is reset the next time the tank is filled.

Operation

Display driving data in the display of the instrument cluster via the multi-functional steering wheel

- › Select the menu item for the driving data in the main menu in the instrument cluster display.

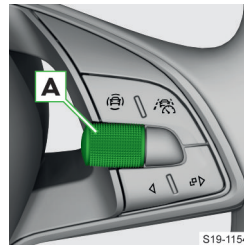

- A** Rotate - Select information/Set values
- Press - Confirm information

Displaying driving data in the infotainment system

The driving data is displayed in the following menu in the infotainment system:

CAR › › › Menu item for driving data

Or:

MENU › › › Menu item for the driving data

Select memory for driving data in the display of the instrument cluster via the multifunction steering wheel and reset it

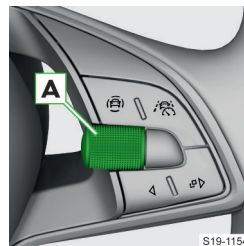

- › To select the memory for the displayed driving data, press control wheel **A** repeatedly.
- › To reset the memory, hold the dial **A**.

Selecting the memory in the infotainment system

To select the memory, use the functional areas **◀ ▶** in the following menu in the infotainment system:

CAR > > Menu item for driving data

Or:

MENU > > > Menu item for the driving data

Resetting the memory in the infotainment system

The memory is reset in the following menu in the infotainment system:

CAR > >

Or:

MENU > > >

Settings

Select driving data to be displayed

The driving data to be displayed is selected in the following Infotainment menu:

CAR > >

Or:

MENU > > >

Setting units

The units are set in the following infotainment menu:

CAR > >

Or:

MENU > > >

Speed limit warning

Usage

The system offers the possibility to set a speed limit beyond which an acoustic warning signal will sound and the following warning message appears in the display of the instrument cluster.

Settings

Setting the speed limit

- > Select *Warning at* or (depending on the display type) and confirm.
- > **When the vehicle is stationary**, set the desired speed limit and confirm.
- > **While driving**, drive at the desired speed and confirm it as the speed limit.

Resetting the speed limit

- > Select *Warning at* or (depending on the display type) and confirm.
- > To reset the speed limit, confirm the stored value.

If the journey is interrupted for more than 2 hours, the set limit is deactivated, but the set value remains stored.

Vehicle status

Display

The vehicle status is displayed in the following menu in the infotainment system:

CAR > > Menu item for the vehicle status

Or:

MENU > > > Menu item for the vehicle status

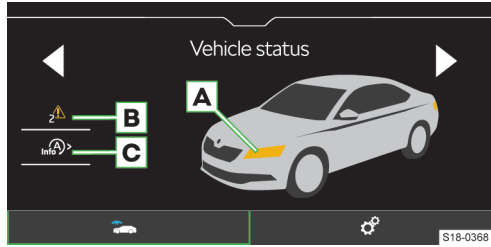

- A** Vehicle areas displayed in colour indicate associated warnings
- B** ✓ No notification
 Warning messages regarding the vehicle condition and their quantity
- C** Display of information about the condition of the START-STOP system
 ▶ Activation/deactivation of information regarding the messages of the START-STOP system in another screen display

Functionality

In the event of a system fault, messages regarding the fault in question are displayed on the instrument cluster display when the ignition is switched on.

Messages in relation to faults can also be displayed in the Infotainment.

I The warning messages will continue to be displayed until the malfunctions have been remedied. After the first display of the message, only the indicator lights (Hazard) or (Warning) are displayed.

Stopwatch in the instrument cluster

Usage

The function Laptimer offers the possibility to use up to 11 lap times, e.g. when driving on a race track, to measure and display in the display of the instrument cluster.

Operation

- › Select *Lap timer* in the main menu in the instrument cluster display.

Displaying functions via the multifunction steering wheel

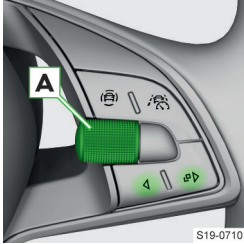

- A** **Rotate** - Select information/Set values
Press - Confirm information

Overview of functions

- ▶ **Start time** - start the timing manually / continue the interrupted measurement
- ▶ **Since start** - Start the timer automatically upon start-up
- ▶ **Statistics** - Evaluate and reset the measured times
 - ▶ Fastest - the fastest lap
 - ▶ Slowest - the slowest lap
 - ▶ Average - the average lap time
 - ▶ Overall time - the total of all the lap times
 - ▶ Reset - reset all measured times
- ▶ **New lap** - Start measurement of the next lap time
- ▶ **Split time** - show the split time
- ▶ **Stop** - interrupt the time measurement
 - ▶ Continue - Continue measurement of the current lap time
 - ▶ New lap - Start measurement of the next lap time
 - ▶ Abort lap - cancel the time without saving the measured time
 - ▶ Exit - cancel the time and save the measured time

Stopwatch in the Infotainment

Overview

The stopwatch display is shown in the menu in the Infotainment:

CAR › › Sport

Or:

MENU › › › Sport

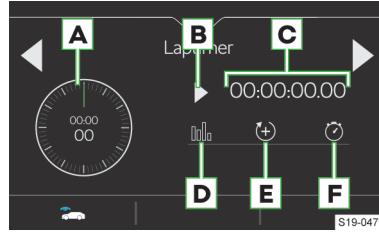

- A** Overall time
- B** ▶ Start the measurement
 □ Stop the measurement
- C** Current lap time
- D** Evaluate/reset split times
 ⌘ End the measurement (the current lap time is not stored)
- E** Start measurement of the next lap time
- F** The split time is briefly shown in the display **A**
 □ End the measurement (the current lap time is stored)

Information Sport

Settings

The Sport information is displayed in the following menu in the infotainment system:

CAR › › Sport

Or:

MENU › › › Sport

A swipe of the finger vertically across the screen allows three of the following displays to be shown:

- ▶ Charging pressure
- ▶ Acceleration
- ▶ Output
- ▶ Coolant temperature
- ▶ Oil temperature

Personalization

Usage

The personalization feature allows each vehicle key to be assigned a user account.

In the user account, settings can be assigned regarding e.g. light function, driver's seat and exterior mirror position, assistance systems, radio, navigation, etc.

Functionality

After opening the driver's door, all the personalised functions are adjusted according to the user account that is assigned to the key which was used to unlock the vehicle.

There are three user accounts and a guest account.

A change to the set personalised functions is automatically stored in the active user account.

Change user account

⚠ WARNING

Risk of an accident!

- ▶ Carry out the account change while the vehicle is stationary.

In the instrument cluster display



- ▶ Switching to a different user account is in the instrument cluster display within 10 seconds after turning on the ignition.

In Infotainment

- ▶ The system settings are made in the Infotainment in the following menu:

CAR > > Vehicle status >

Or:

MENU > > > Vehicle status >

[i] The account changes e.g. when changing drivers while traveling. This avoids unwanted re-setting of the personalized functions in the active user account.

Settings

This function is set in the following menu in the Infotainment system:

CAR > >

Or:

MENU > > >

- ▶ **Key assignment** - Options for assigning the recognised key to the active user account
 - ▶ Manual - the key must be manually assigned to the active account.
 - ▶ Automatic - detected key automatically assigned to a different account of the active account.
- ▶ **Assign the key to the current user account** - Manual assignment of the key to the active account

[i] To maintain the assignment of the selected user account to the selected key, we recommend that you select the manual key assignment.

Infotainment Swing

Infotainment overview

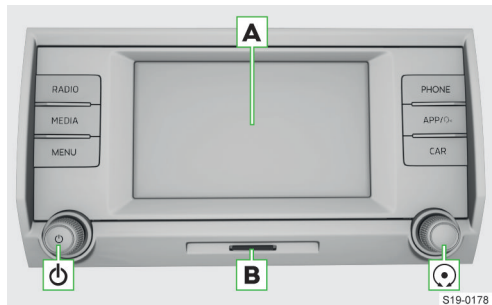

- A** Touchscreen
- B** SD card slot
- Control dial left
 - ▶ **Press:** Switch Infotainment on/off
 - ▶ **Turn:** Set volume
- Control dial right
 - ▶ **Press:** Confirm menu item
 - ▶ **Turn:** select menu item/set value
- RADIO** Radio menu
- MEDIA** Media menu
- MENU** Overview of Infotainment menus
- PHONE** Phone menu
- APP/** SmartLink menu
 - ▶ **Press:** Display menu
 - ▶ **Hold:** Switch voice control of the SmartLink application on / off
- CAR** Information about vehicle settings

System

Limitation

For safety reasons, operation of some Infotainment functions while driving is not possible or is restricted.

The Infotainment system indicates this by means of a message in the screen.

Basic settings

Setting basic functions

The following Infotainment functions are set in the menu **SETUP**:

- ▶ Time and date
- ▶ Language
- ▶ Units

- ▶ Restore factory settings

Sound settings

The Infotainment sound is set in the menu **SETUP** › *Sound*.

The following menu items can be set:

- ▶ Setting the maximum volume when Infotainment is turned on
- ▶ Volume adjustment of individual Infotainment functions
- ▶ Setting the equalizer
- ▶ Adjusting the volume ratio

Depending on the equipment, the following advanced sound settings can be set

- ▶ Setting the sound system
- ▶ Setting the sound space optimisation for the driver
- ▶ Turn on/off and adjust the subwoofer volume

Configuration wizard

The configuration wizard helps to set certain Infotainment functions.

The configuration wizard is automatically displayed if, after switching on the Infotainment system, there are at least two menu items that have not been set or if a new user account has been selected.

- › To **switch off the automatic display**, when the configuration wizard is displayed tap *Don't show again*.
- › For **manual display** tap **SETUP** › *Configuration wizard*.

Safely disconnect the connected USB device

ⓘ NOTICE

Risk of damage to the data on the connected device! To safely disconnect/remove the device, proceed as follows:

- › **SETUP** › *Remove safely*.
- › Select the desired device.
- › Disconnect/remove the device.

i If it is not possible to safely disconnect the device, switch off the Infotainment and disconnect the device.

Troubleshooting

Infotainment not responding

If the infotainment does not respond, restart it as follows:

- › Hold ϕ for longer than 10 s.
- › Wait for the restart to complete.

System update

We recommend having the system update carried out by a specialist company.

The system update ensures optimal function of the Infotainment system, e.g. compatibility with new phones.

Determine system version

- › **SETUP** › *Tap System information*.

Manual update

Information about available updates can be found on the ŠKODA website.

<http://go.skoda.eu/updateportal>



- › Check for available updates.
- › Save the update to a USB source.
- › Insert the USB source into the front USB input.
- › **SETUP** › *Tap System information* › *Tap Update software*.
- › Select the connected USB device as the update source.
- › Go to the update file and confirm the update.
- › Confirm any messages and wait for the update process to complete.

Screen

Overview

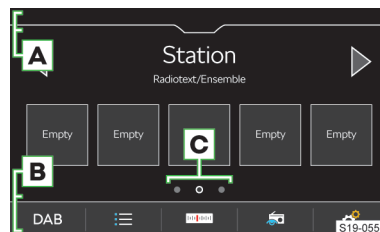

- A** Status bar
- B** Bar with the functional surfaces of the displayed menu
- C** Other pages of the menu

Operation

ⓘ NOTICE

Danger of screen damage!

- ▶ The Infotainment screen is operated **by touching it lightly with your finger**.

In principle, operation by touch is identical to the operation of a mobile phone.

The following operating modes are specific to the Infotainment system.

Settings

The following basic screen functions are set in the menu **SETUP** › Screen:

- ▶ Brightness level of the screen
- ▶ Switch off the screen
- ▶ Display the time
- ▶ Confirmation sounds and animations

Infotainment keyboard

Keypad overview

The arrangement of the keyboard characters depends on the set infotainment language.

Depending on the context, the following types are used in infotainment:

- ▶ Alphanumeric
- ▶ Numeric
- ▶ Keyboard for input
- ▶ Keyboard for search

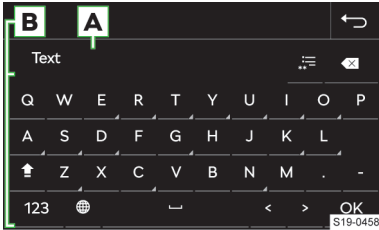

Keypad example

A Input line

- ▶ Delete characters before the cursor
 - ▶ **Tap:** delete the last character
 - ▶ **Hold:** delete all characters in sequence
- ▶ Show list of searched entries

B Keypad functional surfaces

- ▶ Change to lowercase
- ▶ Switch to the first capital letter, followed by lowercase letters
- ▶ Switch to the language keypad
- ▶ Switch to the numeric and character keypad
- ▶ Show additional keypad languages
- ▶ Insert a space
- ▶ **Hold:** Show additional character variants
- ▶ Move cursor to the left
- ▶ Move cursor to the right
- ▶ Confirm the characters that have been entered

Numeric keypad

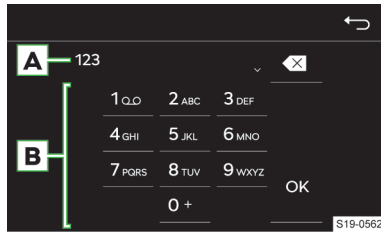

Keypad example

A Input line

- ▶ Delete characters before the cursor
 - ▶ **Tap:** delete the last character
 - ▶ **Hold:** delete all characters

B Keypad functional surfaces

- ▶ Confirm the characters that have been entered
- If context-sensitive, alphanumeric characters can be entered by holding a functional surface with a digit.

Operation

The Infotainment keypad is used to enter characters, letters and numbers.

The keypad will be **automatically displayed** when Infotainment prompts for characters.

Find

During the character input, a search for corresponding entries takes place.

The entry to be searched can be entered, including diacritics.

The keypad will only provide characters that match the stored entries.

- › To **display the searched entries**, tap .

Show additional keypad languages

To use the additional keypad languages, the desired languages must be set first.

- › Tap or repeatedly tap the flag symbol until the desired language keypad is displayed.

Further character variants

- › Press and hold the sign with the symbol .
- › Select the desired symbol.

Setting up additional keyboard languages

- › **SETUP** › Additional keyboard languages .

Control centre

Overview

Display of the control centre



› Press the bar at the top of the screen and drag down.

Closing the control centre

› Tap on ▲.

Or:

› Wait 5 seconds.

Control Centre

The Infotainment control centre can be used for quick access to the following functions:

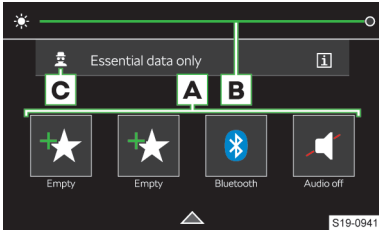

- A** Preferred functions
- B** Setting the instrument and key illumination
- C** Setting the personal data protection level

Settings

- › To **display** editing mode hold any function surface of the preferred feature.
- › To **add** the preferred feature, move the desired feature from the top of the screen to the functional surface at the bottom of the screen.
- › To **close** edit mode, tap on ×.

Radio

Overview

Display menu

› Tap on **RADIO**.

Analogue and digital radio reception

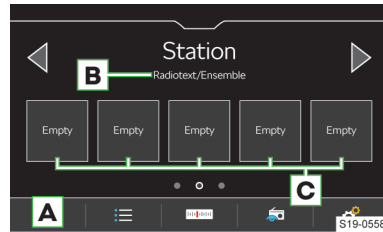

- A** Select frequency range
- B** Depending on the frequency range
 - FM:** Radio text
 - DAB:** Name of the station group
- C** Preset buttons for preferred stations
 - ☰ List of available stations
 - 🔍 Manual station search
 - 📄 Display information about the station (applies to DAB)
 - ⚙️ Settings

i Infotainment supports digital radio reception in DAB and DAB+ formats.

List of available stations

› To **display**, tap ☰.

- ⦿ Played station
- ★ Station stored on the presets
- TP A traffic radio station is set
- 📶 DAB signal is not available
- 📶 The DAB station reception is not stable
- ▼ Filtering the stations in the list according to the programme type.
 - To filter the FM stations, the RDS and AF function must be switched on.
 - To filter the DAB stations, the alphabetical sorting function of the stations must be activated.
- 🔄 Manual update of the station list

In the FM station list, information about the programme type and the type of the regional station can be displayed.

Operation

Select station

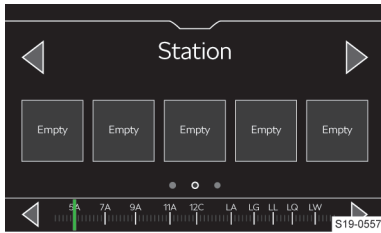

- › Tap ◀ or ▶ at the top of the screen.

SCAN function

The function plays receivable stations of the selected frequency range in succession for a few seconds each.

- › To **start automatic play** press > Scan or the right rotary control .
- › To **end automatic play** press or the right rotary control .

Find stations manually

- › In the Radio main menu, tap .
- › To **search in sequence**, tap ◀ or ▶ next to the displayed frequency range scale.

Or:

- › Hold down the scroll mark on the frequency range scale and move it to the desired value.

Or:

- › Turn the right rotary control .

Limitation

- ▶ Infotainment supports digital radio reception in DAB and DAB+ formats.
- ▶ Parking garages, tunnels, tall buildings or mountains can restrict radio reception.
- ▶ In the rear side windows, there are antennas for receiving the radio signal.
Covering the windows with foils or metal-coated stickers can impair the reception of the radio signal.
- ▶ The ŠKODA AUTO company does not assume any responsibility for the availability, correct function or broadcast information of the RDS service.

Settings

Save the station currently being listened to as a favourite from the Radio main menu

- › Hold the desired station key for preferred stations until the station is stored.

Save station to favourites from the list of available stations

Applies to AM, FM and DAB frequency ranges.

- › Hold the line with the name of the desired station.
- › Tap the desired preset button.

Deleting favourites

- › In the menu **Radio** > *clear memory* .
- › To delete a station button for preferred stations, tap the desired station button and confirm the deletion.
- › To delete **all** station buttons for preferred stations Tap *All* and confirm the deletion.

Function surfaces ◀ ▶

Applies to AM, FM and DAB frequency ranges.

The variant for **changing stations** using the function surface ◀ ▶ in the **Radio** menu is set as follows:

- › In the menu **Radio** > *Arrow buttons* .
- › Choose the change variant.

Traffic reception (TP) for FM stations on/off

Applies to the FM frequency range.

- › In the menu **Radio** > *Traffic program (TP)* .

Switch traffic reception for DAB stations on/off

Applies to the DAB frequency range.

- › In the **Radio** menu switch on the menu item > *Traffic program (TP)* switch on
- › In the menu **Radio** > *Advanced settings* > *Tap DAB traffic announcements* switch on / off

Assign station logo from an external source

Applies to AM, FM and DAB frequency ranges.

Infotainment offers the option to assign logos from the pictures on an external source to the station buttons.

For station logos, images in jpg, png format with a maximum resolution of 400x240 pixels can be used.

- › In the menu **Radio** > *Station logos* .
- › Tap the desired preset button.
- › Select the external source with the logo.
- › Find the desired logo and confirm.

Delete station logos

Applies to AM, FM and DAB frequency ranges.

- › In the menu **Radio** > *Station logos* .
- › To delete a **logo**, tap the desired preset button and confirm the deletion.
- › To delete **all logos** Tap *All* and confirm the deletion.

Turn on/off radio text reception

Applies to the FM and DAB frequency ranges.

When the function is switched on and station presets are displayed, detailed information about the broadcast content of the FM station being listened

to, or the name of the station group for the DAB station, is displayed.

› In the menu **Radio**  › Radio text .

Switch automatic frequency control (AF) on/off

Applies to the FM frequency range.

When the function is switched on and the signal of the FM station currently being listened to is weak, Infotainment automatically sets the same station to a different frequency with a better signal.

› In the menu **Radio**  › Advanced settings › Automatic frequency change (AF) .

Sort stations in the list of available stations

Applies to the FM frequency range.

› In the menu **Radio**  › Advanced settings › Station list: .

› Select the sorting of stations in alphabetical order or by group.

Automatic change of frequency to a regionally linked FM station

Applies to the FM frequency range.

Infotainment provides the option of automatically switching to a regionally linked FM station in case of signal loss of the FM station being listened to.

› In the menu **Radio**  › Advanced settings › RDS Regional: .

› Select one of the following menu items:

- ▶ *Fix* - When the signal is lost, another station must be set manually.
- ▶ *Automatic* - automatic selection of the station with the best signal reception.

i If reception is lost in the given region, Infotainment will automatically set another available region.

Switch RDS on/off

Applies to the FM frequency range.

The menu item is only available for some countries.

› In the menu **Radio**  › Advanced settings › Radio Radio Data System (RDS) .

If the **RDS function is disabled**, the following menu items in **FM station** settings are not available:

- ▶ Traffic program (TP)
- ▶ Radio text
- ▶ RDS Regional
- ▶ Automatic frequency change (AF)

Switching additional announcements of the DAB transmitter on / off

Applies to the DAB frequency range.

When the function is switched on, other announcements are received as traffic announcements. These include e.g. weather news, sports reports, financial news etc.

› In the menu **Radio**  › Advanced settings › Tap other DAB announcements .

Enable/disable automatic programme tracking of a DAB station

Applies to the DAB frequency range.

When the function is switched on and the DAB station is lost, Infotainment automatically changes to the same station with a better signal in a different DAB station group.

› In the menu **Radio**  › Advanced settings › DAB - DAB program tracking .

Turn on/off automatic switching from a DAB station to the same FM station

Applies to the DAB frequency range.

When the function is switched on and the DAB station being listened to is lost, Infotainment automatically changes to the same FM station. The symbol (FM) is displayed after the station name.

When the corresponding DAB station can be received again, the station automatically changes from FM to DAB.

› In the menu **Radio**  › Advanced settings › Tap Automatic change DAB - FM .

Switch the slideshow function on/off

Applies to the DAB frequency range.

When the function is switched on, the images broadcast by the station are displayed in the player.

› In the menu **Radio**  › Advanced settings › DAB slideshow .

Media

What you should be mindful of

- ▶ Do not save any important data or that which has not been backed up on the connected audio sources. ŠKODA assumes no responsibility for lost or damaged files or connected audio sources.
- ▶ When changing or connecting an audio source, this may cause sudden changes in volume. Reduce the volume before changing or connecting an audio source.
- ▶ When connecting an audio source, the source information messages can be displayed. These messages must be observed and, if necessary, confirmed.
- ▶ The national copyright laws that apply in your country must be observed.

Overview

Display menu

› Tap **MEDIA**.

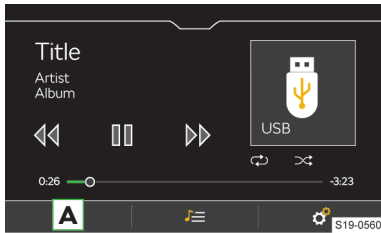

A Select source

☰ Manage files / multimedia database

⚙ Settings

Operation

Operation - Basics

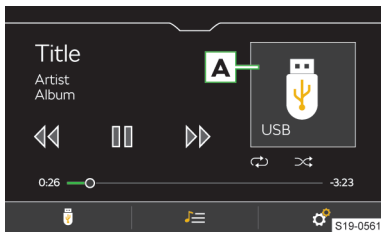

A Album image / symbol of the connected source

Tap: display available albums

▶ **Tap:** start playback

⏸ **Tap:** pause

⏮ **Within 3 seconds of starting playback, tap:** play the previous song

⏮ **After 3 seconds from the start of playback, tap** to play the current title from the beginning

⏮ **Hold:** fast rewind within the title

▶ **Tap:** play the next song

▶ **Hold:** fast forward within the title

Movement within the title is also possible by dragging the finger over the timeline.

Extended operation

🔄 Turn repeat playback of the current track on/off

🔄 Turn repeat playback of the current album/folder on/off

⌂ Turn random playback of the current album/folder on/off

Restriction

The availability of some media operation functions is dependent on the connected source and the software being used, e.g. Bluetooth®.

Settings

Turn title playback including subfolders on/off

› In the **Media** menu tap on ⚙ > *Mix/Repeat including subfolders*.

Traffic

› To **turn on/off** traffic monitoring during playback of media files, go to the **Media** in the main menu ⚙ > and tap on *Traffic program (TP)*.

Safely disconnect the connected device

ⓘ NOTICE

Risk of damage to the data on the connected device! To safely disconnect/remove the device, proceed as follows:

› In the **Media** menu tap on ⚙ > *Remove safely*.

› Select the desired device.

› Disconnect/remove the device.

ⓘ If it is not possible to safely disconnect the device, switch off the Infotainment and disconnect the device.

Bluetooth® player

Infotainment allows audio files of a connected Bluetooth® player to play using the A2DP and AVRCP audio profile.

With Infotainment, multiple devices can be paired using Bluetooth®, but only one of them can be used as a Bluetooth® player.

› For **connecting the Bluetooth® player**, pair and connect the device via Bluetooth®.

› In the **Media** menu tap on ⚙ > *Bluetooth* > *Paired devices*.

› In the list, choose the device with the symbol ⌂.

ⓘ If a device is connected to Infotainment using Apple CarPlay or Android Auto, then it cannot be connected using Bluetooth®.

SD card

ⓘ NOTICE

Risk of damaging the SD card reader!

▶ Do not use SD cards with a broken slide for write protection.

› To **insert** the SD card, with the bevelled corner to the right, push into the slot in the external module until it snaps into place.

› To **remove**, first disconnect the SD card safely. For this in the menu **media** ⚙ > tap on *Remove safely*: and select the SD card.

› Press on the inserted SD memory card.

The SD card moves to the eject position.

ⓘ NOTICE

When using an SD card with an adapter, vehicle vibrations might cause the card to fall out of the adapter.

USB device

- › To **connect**, insert the USB device into the appropriate port.
To play audio files, use USB ports that support data transfer.
- › To **disconnect** disconnect the USB device first. For this in the menu **media**  › tap on *Remove safely*: and select the USB device.
- › Disconnect the USB device.

i A USB device can be connected directly to the USB port or via a connection cable. We recommend using connection cables from the ŠKODA Original Accessories range. USB extension cables or reducers may affect the playback function of the connected device.

Load USB audio source

After connecting the USB device, charging will start automatically when the following conditions are met:

- ✓ The ignition is switched on.
- ✓ The USB device allows charging.

The charging efficiency can be different compared to the charging from the usual mains power supply.

Depending on the type of the connected USB device and the frequency of use, the charging current may not be sufficient to charge the battery of the connected device.

Some connected audio sources may not be recognised and cannot be charged.

Supported sources and files

Supported sources

Source	Interface	Type	Specification	File system
SD card	SD card reader	Standard size	SD SDHC SDXC	
USB	USB 1.x; 2.x 3.x or higher with USB 2.x support	MSC	USB stick HDD (without special software)	FAT16 FAT32 exFAT
			USB devices that support the USB Mass Storage protocol	
		MTP	Devices running the Android or Windows Phone operating system that support the Media Transfer Protocol	
		Apple	Devices with an iOS operating system	HFS+
Bluetooth® player	Bluetooth®	-	Bluetooth® protocols A2DP and AVRCP (1.0 - 1.5)	-

i The GPT standards (GUID partition table) method structured audio sources are not supported by Infotainment.

Viewing images on the Infotainment screen is not supported by connected Apple devices.

Compatibility of mobile devices

It is possible to check the ŠKODAweb pages to see if Infotainment is compatible with the selected mobile device being tested. This check is carried out by using the following reference or by reading the QR code:

 <http://go.skoda.eu/compatibility>



All information given is incidental and serves as information.

The ŠKODA AUTO company cannot guarantee full functionality and compatibility, e.g. due to a software update of the Infotainment and the mobile devices.

Supported audio files

Compression format	Codec type	File extension	Max. bit rate [kbps]	Max. sampling rate [kHz]	Multi channels
MPEG	MPEG 1 Layer 3	mp3	32 - 320	32, 44, 48	Mono, Dual Mono, Stereo, Joint Stereo
	MPEG 2 Layer 3	mp3	8 - 160	16, 22, 24	Mono, Stereo, Joint Stereo
	MPEG 2.5 Layer 3			8, 11, 12	
WMA	Windows Media Audio 9 and 9.1	wma	8 - 384	8, 11, 12, 16, 22, 32, 44, 48	Mono, Stereo, Joint Stereo
	Windows Media Audio 9.2		8 - 320		
	Windows Media Audio 10		8 - 384	32, 44, 48, 96	

 Files that are protected by **DRM**- and **iTunes**[®] methods are not supported by Infotainment.

Supported playlists

Codec type	File extension
M3U	m3u
PLS	pls
WPL	wpl
ASX	asx



Mobile device management

Overview

Mobile device management

› In the **Telephone**  › menu **Bluetooth** › *Paired devices* .

In the list of paired mobile devices, the following symbols may appear for the individual devices:

-  **White icon** - the device can be connected as a telephone.
- Green icon** - the device is connected as a telephone.
-  **White icon** - the device can be connected as a Bluetooth[®] player.
- Green icon** - the device is connected as a Bluetooth[®] player.

Possible functions of the connected mobile device

The functions of a device connected via over the **HFP** Bluetooth profile depends on the following connection types.

First device Main phone	Second device Additional phone
incoming / outgoing calls Telephone contacts Bluetooth [®] player	Bluetooth [®] player

With Infotainment only a **mobile device** can be connected as a Bluetooth[®] player.

Limitations of mobile devices and applications

Availability of features

The availability of certain features depends on the type of mobile device, as well as that of the applications installed.

Connection restrictions

- ▶ With Infotainment, a max. of 20 mobile devices are paired.
- ▶ The range of the connection of the mobile device to Infotainment is limited to the passenger compartment.
- ▶ After reaching the maximum number, the pairing of the next mobile device will replace that of the device that has not been used for the longest period of time.

Compatibility of mobile devices

It is possible to check the ŠKODAweb pages to see if Infotainment is compatible with the selected mobile device being tested. This check is carried out by using the following reference or by reading the QR code:

 <http://go.skoda.eu/compatibility>



All information given is incidental and serves as information.

The ŠKODA AUTO company cannot guarantee full functionality and compatibility, e.g. due to a software update of the Infotainment and the mobile devices.

Bluetooth® compatibility of mobile devices

Due to the large number of mobile devices, it is not possible to guarantee total Bluetooth® compatibility with Infotainment. Bluetooth® compatibility depends on the Bluetooth® version as well as the implementation of Bluetooth® protocols by the manufacturer of the mobile device.

Applications in mobile devices

Mobile devices can be used to install applications that allow you to view additional information on the Infotainment screen, or to operate the Infotainment system.

Due to the variety of applications, as well as their ongoing development, the available applications may not function on all mobile devices. ŠKODA AUTO assumes no liability for their proper functioning.

The scope of available applications and their functionality is dependent on the type of Infotainment, as well as the vehicle and country.

Information about ŠKODA applications

Detailed information about ŠKODA applications can be found on the website after reading the following QR code or link:

 <http://go.skoda.eu/mobile-apps>



Connection set-up

Connect a mobile device to Infotainment

- › Turn on the ignition.
- › Turn on the Bluetooth® on the mobile device.
- › The infotainment Bluetooth® **SETUP** › *Bluetooth* › *Bluetooth* switch on
- › Bluetooth® visibility of the infotainment **SETUP** › *Bluetooth* › *Visibility*: › *Visible* switch on
- › Find available Bluetooth® devices in the mobile device.
- › Select the Infotainment Bluetooth® unit.

The name of the unit can be found by tapping on **SETUP** › *Bluetooth* › *Name*: .

- › Confirm the PIN; enter it if necessary and then confirm.

The mobile device is connected to the Infotainment or just paired, depending on the number of devices that are already connected.

Connect Infotainment to a non-paired mobile device

- › Turn on the ignition.
- › Turn on the Bluetooth® on the mobile device.
- › The infotainment Bluetooth® **SETUP** › *Bluetooth* › *Bluetooth* switch on
- › **SETUP** › *Bluetooth* › *Search devices* .
- › Ensure the visibility of the device to be connected.
- › Select the desired device from the list of Bluetooth® devices.
- › Confirm the PIN; enter it if necessary and then confirm.
- › If two devices are connected to the Infotainment, select the device to be replaced.

Connect Infotainment to a mobile device that is already paired

The connection with an already paired mobile device is made automatically after switching on the ignition; if necessary the device can be connected manually as follows:

- › Turn on the ignition.
- › Turn on the Bluetooth® on the mobile device.
- › The infotainment Bluetooth® **SETUP** › *Bluetooth* › *Bluetooth* switch on

- › **SETUP** › Bluetooth › Paired devices .
- › In the device list, select the desired device and the Bluetooth® profile.
- › Confirm the PIN; enter it if necessary and then confirm.
- › If two devices are connected to the Infotainment, select the device to be replaced.

Disconnect from a mobile device

- › **SETUP** › Bluetooth › Paired devices .
- › Tap on the Bluetooth® profile icon of the desired mobile device.

Delete a paired mobile device

- › **SETUP** › Bluetooth › Paired devices .
- › To **delete** a mobile device, tap  and confirm the deletion.
- › To **delete all** mobile devices, tap *Clear all* and confirm the deletion.

Telephone





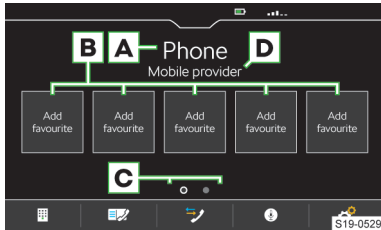

Phone menu

Display menu

- › Tap on **PHONE**.

 If the menu **phone** is not displayed, check whether the mobile device is connected.





- A** Name of the connected telephone
 - ▶ **Tap:** Show list of previously connected phones
- B** Preset buttons for preferred contacts
- C** Choice of storage group for the preferred contacts
- D** Name of telephone service providers
 - ▶ If the symbol  is displayed in front of the name, roaming is active.
-  Enter telephone number
-  Contact list
-  Call lists
-  Switch on voice control for the connected telephone
-  Settings

Conditions for connecting a telephone with Infotainment

- ✓ The ignition is switched on.
- ✓ The Bluetooth® function of the Infotainment and the telephone needs to be switched on.
 - The Bluetooth® function of the Infotainment is switched on in the menu item **SETUP** › Bluetooth › Bluetooth.
- ✓ Visibility of the Infotainment is switched on.
 - The visibility of the Infotainment is switched on in the menu item **SETUP** › Bluetooth › Visibility:› Visible.
- ✓ The telephone is within signal range of the Infotainment's Bluetooth® unit.
- ✓ The telephone is compatible with Infotainment.
- ✓ No mobile device is connected to the Infotainment using Apple CarPlay®.

Telephone operation

Enter telephone number

- › In the **Phone** menu, tap on .
 - › Enter the telephone number using the numeric keypad that is displayed.
-  The displayed numeric keypad can also be used for searching for contacts. If, for example, the digits 32 are entered, contacts with the letter sequence DA, FA, EB etc. are displayed next to the numeric keypad.

List of telephone contacts

The list of telephone contacts is imported from the connected main telephone.







- › To **display** the contact list in the **phone** menu, tap on .
- › To **search** within the list, tap on *Find* .
- › Enter the details you wish to find.
- › To **establish a connection** with a contact, tap the functional area showing the desired contact.

If a contact has multiple telephone numbers, select the telephone number from the displayed list.

- › To display the **details** for a contact, tap > .

Telephone conversation

Depending on the context of the telephone conversation, the following functions can be selected:

-  End connection / reject incoming call / end call
-  Answer an incoming call / return to the held call
-  Switch the ringer off / on
-  Hold a call
-  Switch the microphone off / on
-  Show details of the caller

- › To **switch the call tone from the speakers to the telephone**, go to **telephone** in the menu and tap on > *speakerphone* .
- › To **switch the call tone from the telephone to the speakers**, tap .

Settings for Infotainment telephone functions

Manage preset buttons for preferred contacts

- › To **save** the desired preset button, press and hold.
- › Select a contact from the displayed list.
- › If the contact contains multiple telephone numbers, choose the desired telephone number.
- › To **Clear** in the **telephone** menu tap > *User profile* > *Manage favourites* .
- › To delete **one** preset, tap on the list entry and confirm the deletion.

Or:

- › To delete **all** station buttons, tap *Clear all* and confirm the deletion.

Import telephone contacts

After first connecting the main telephone with Infotainment, telephone contacts will start to be imported into the Infotainment memory.

Infotainment can import up to 2000 telephone contacts. Each contact can include max. 5 telephone numbers.

Depending on the type of telephone, import confirmation may be required.

Update telephone contacts

When re-connecting the telephone with Infotainment, an **automatic** update of the list is carried out.

- › For **manual** update of the list in the **phone** > menu *User profile* > tap on *Import contacts* .

Sort contacts in the phone book

- › In the **Telephone** > menu *User profile* > *Sort by:* .
- › Select the type by which to sort.

Ringtone

Some phones do not allow the use of the telephone ringtone; instead, the Infotainment ringtone is used.

- › For **setting the Infotainment ringtone** in the **phone** > menu *User profile* > *select the ringtone* .
- › Select the ringtone.

Simultaneous calls

This applies to some countries.

Depending on the connected telephone, it is possible to answer the next incoming call and hold the previous call.

- › To **switch on/off** simultaneous calls, tap on **telephone** > *Simultaneous calls* .

SmartLink

Functionality

SmartLink offers the ability to display and operate certified applications from a connected mobile device in the Infotainment screen.

Certification may be conditional upon the use of the latest update to the particular SmartLink application.

Applications include, for example, apps for route guidance, telephoning, listening to music, etc.

Mobile devices can be connected via a USB cable.

Supported connection types

SmartLink supports the following connection types:

- ▶ Android Auto
- ▶ Apple CarPlay
- ▶ MirrorLink

Overview of the SmartLink connection

Menu SmartLink

- › Tap on **APP**/ .

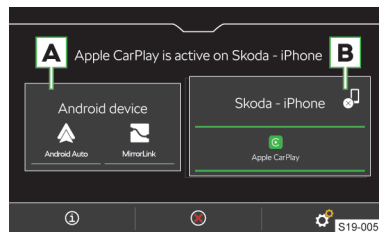

- A** Previously connected device
- B** Currently connection device
- Display information about SmartLink
- Disconnection of the active connection
- Disconnection of the active connection
- Settings in SmartLink menu

Android Auto

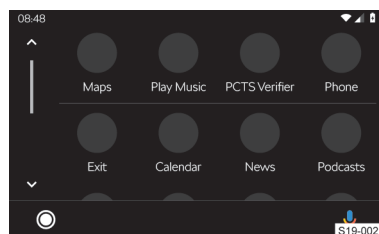

- Overview of running applications, phone calls, incoming text messages, and more.
- Turn on voice control (Google Voice)

Apple CarPlay

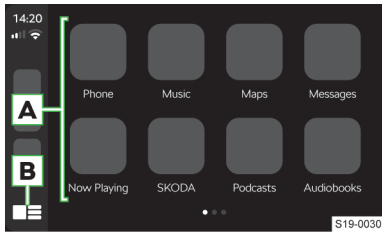

- A** List of available applications
- B** Depending on the duration of operation:
 - ▶ **Tap:** Return to the menu Apple CarPlay
 - ▶ **Hold:** Turn on voice control (Siri)

MirrorLink

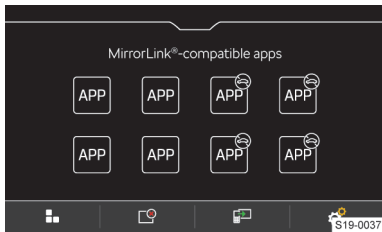

- ⊖ It is not possible to operate the application while driving
- ☰ Return to the menu SmartLink
- ☰ List of running applications
- ☰ Display of the last running application in connected mobile devices
- ⚙ Settings

Connection conditions

General connection conditions

- ✓ The mobile device supports the type of SmartLink connection Android Auto, Apple CarPlay or MirrorLink.
- ✓ Mobile devices, as well as the type of SmartLink connection, are supported in the respective market.
- ✓ Some connected mobile devices require the mobile device to be “unlocked”.

Conditions for Android Auto

- ✓ The device to be connected must have Android Auto connection.
A list of devices, supported regions and applications that support the Android Auto connection can be found on the Google, Inc. website.
- ✓ The Android Auto application needs to be installed on the mobile device.

- ✓ Some applications require the data connection in the mobile device to be turned on.
- ✓ Connect the mobile device for the first time when the vehicle is stationary.

Conditions for Apple CarPlay

- ✓ The device to be connected must have Apple CarPlay connection.
A list of devices, supported regions and applications that support the Apple CarPlay connection can be found on the Apple Inc website.
- ✓ Siri voice control is on.
- ✓ The data connection in the mobile device is switched on.

Conditions for MirrorLink

- ✓ The device to be connected must have MirrorLink connection.
A list of devices and applications that support the MirrorLink connection can be found on the websites of Car Connectivity Consortium®.
- ✓ The MirrorLink application needs to be installed on the mobile device.
- ✓ Some applications require the data connection in the connected mobile device to be turned on.

Operation

Operation of the running MirrorLink application

- < Move the functional areas to the left edge of the screen
- > Move the functional areas to the right edge of the screen
- ^ Move the functional areas to the top of the screen
- v Move the functional areas to the bottom of the screen
- ☰ Return to the menu MirrorLink

Restriction

Restriction of SmartLink applications while driving

For reasons of safety, the operation of some SmartLink applications while driving is not possible or only limited.

Functionality restriction of Infotainment with an Android Auto connection

- ▶ For the duration of the connection, the external device cannot be used as an audio source in the **Media** menu.
- ▶ By connecting the device, all currently connected Bluetooth® devices will be disconnected and the device will automatically be connected as the main telephone.

- ▶ For the duration of the connection, no other Bluetooth® devices can be connected to the Infotainment system.

Functionality restriction of Infotainment with an Apple CarPlay connection

- ▶ For the duration of the connection, the external device cannot be used as an audio source in the **Media** menu.
- ▶ Connecting the device disconnects all currently connected Bluetooth® devices.
- ▶ For the duration of the connection, no Bluetooth® devices can be connected to the Infotainment system.

Functionality restriction of Infotainment with an MirrorLink connection

- ▶ For the duration of the connection, the external device cannot be used as an audio source in the **Media** menu.
- ▶ By connecting the device, all currently connected Bluetooth® devices will be disconnected and the device will automatically be connected as the main telephone.

Depending on the device to be connected, a connection confirmation may be required.

- › Choose to connect through MirrorLink.

MirrorLink - Disconnect

- › In the MirrorLink menu, tap on .
- › Tap on .

Change to another device / connection type

Infotainment allows you to switch between currently connected devices and the connection type.

- › Tap on **APP**/.
- › Select the desired device or connection type.

Settings

Apple CarPlay - Connection via USB

- › Turn on the Infotainment.
- › Turn on the mobile device.
- › Connect the mobile device to the front USB input using a cable.
- › Choose to connect via Apple CarPlay.



Apple CarPlay - Disconnect

- › In the Apple CarPlay menu, tap on the function area “ŠKODA”.
- › Tap on .

Android Auto - Connection via USB

- › Turn on the Infotainment.
- › Turn on the mobile device.
- › Connect the mobile device to the front USB input using a cable.
- › Choose to connect via Android Auto.

Android Auto - Disconnect

- › In the Android Auto  > menu, tap “Return to SKODA”.
- › Tap on .

MirrorLink - Connection via USB

- › Turn on the Infotainment.
- › Turn on the mobile device.
- › Connect the mobile device to the front USB input using a cable.

Infotainment Bolero

Infotainment overview

Bolero Infotainment system with navigation function

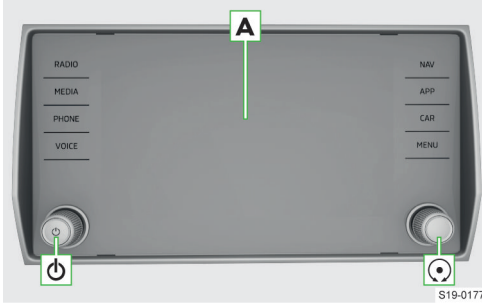

- A** Touchscreen
- ⌚ Control dial left
 - ▶ **Press:** Switch Infotainment on/off
 - ▶ **Turn:** Set volume
- ⌚ Control dial right
 - ▶ **Press:** Confirm menu item
 - ▶ **Turn:** select menu item/set value

- RADIO** Radio menu
- MEDIA** Media menu
- PHONE** Phone menu
- VOICE** Voice control
- NAV** Navigation menu
- APP** SmartLink menu
- CAR** Information about vehicle settings
- MENU** Overview of Infotainment menus

Bolero Infotainment without the navigation function

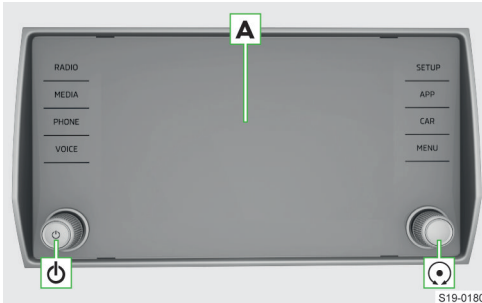

- A** Touchscreen
- ⌚ Control dial left
 - ▶ **Press:** Switch Infotainment on/off

- ▶ **Turn:** Set volume
- ⌚ Control dial right
 - ▶ **Press:** Confirm menu item
 - ▶ **Turn:** select menu item/set value

- RADIO** Radio menu
- MEDIA** Media menu
- PHONE** Phone menu
- VOICE** Voice control
- SETUP** Infotainment settings
- APP** SmartLink menu
- CAR** Information about vehicle settings
- MENU** Overview of Infotainment menus

System

Limitation

For safety reasons, operation of some Infotainment functions while driving is not possible or is restricted.

The Infotainment system indicates this by means of a message in the screen.

Basic settings

Setting basic functions

The following Infotainment functions are set in the **MENU** > menu:

- ▶ Time and date
- ▶ Language
- ▶ Units
- ▶ Restore factory settings

Sound settings

The Infotainment sound is set in the menu **MENU** > .

The following menu items can be set:

- ▶ Setting the equalizer
- ▶ Adjusting the volume ratio
- ▶ Volume adjustment of individual Infotainment functions

The volume can be adjusted on e.g. one of the following menu items:

- ▶ Volume adjustment of voice commands
- ▶ Setting the maximum volume when Infotainment is turned on
- ▶ Speed-dependent volume setting
- ▶ Setting the Infotainment to mute with the parking aid switched on

Depending on the equipment, the following advanced sound settings can be set

- ▶ Setting space optimisation

- ▶ Setting the audio profiles according to genre
- ▶ Adjusting the subwoofer volume

Configuration wizard

The configuration wizard helps to set certain Infotainment functions.

The configuration assistant is automatically displayed if the ignition is switched on and if there are at least two menu items that have not been set up after switching on the Infotainment.

- ▶ To **switch off the automatic display**, when the configuration assistant is displayed tap *Don't show again*.
- ▶ For **manual display** tap MENU > ⚙ > Configuration wizard.

Set up menu HOME

- ▶ To **display another page** of the HOME menu, press the screen with two fingers and drag it to the left or right.

To **add the preferred menu**, proceed as follows:

- ▶ Tap on an empty functional surface.

Or:

- ▶ Press and hold an occupied functional surface and then tap on an empty functional area.
- ▶ Select a menu with the desired dimension of the functional surface.
- ▶ Tap on × to exit edit mode.

To **remove the preferred menu**, proceed as follows:

- ▶ Press an occupied functional surface.
- ▶ Tap on ⌂.
- ▶ Tap on × to exit edit mode.

Set up menu MENU

The position of the functional surfaces in the MENU menu can be customized as follows:

- ▶ Press and hold the desired functional surface until it is free.
- ▶ Move the functional surface to a different position.

Troubleshooting

Infotainment not responding

If the infotainment does not respond, restart it as follows:

- ▶ Hold ⏻ for longer than 10 s.
- ▶ Wait for the restart to complete.

System update

We recommend having the system update carried out by a specialist company.

The system update ensures optimal function of the Infotainment system, e.g. compatibility with new phones.

Determine system version

- ▶ Tap MENU > ⚙ > System information.

Install the navigation function

In some countries it is possible to use the Infotainment to extend the function of **Navigation**.

The function is available through the online service **Shop** or from a specialist company.

Screen

Overview

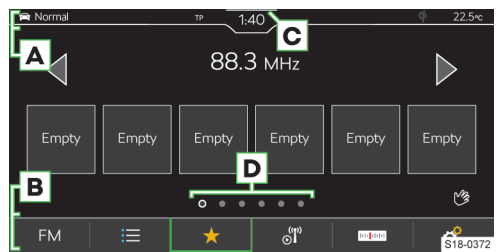

- A** Status bar
- B** Bar with the functional surfaces of the displayed menu
- C** Display of the control centre
- D** Other pages of the menu

Operation

! NOTICE

Danger of screen damage!

- ▶ The Infotainment screen is operated **by touching it lightly with your finger**.

In principle, operation by touch is identical to the operation of a mobile phone.

The following operating modes are specific to the Infotainment system.

Dragging up or down with two fingers

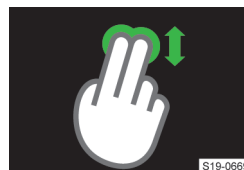

- ▶ Quickly review the list of phone contacts
- ▶ Switch 2D/3D map display

S19-0669

Dragging left or right with two fingers

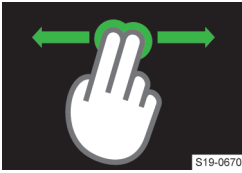

S19-0670

- ▶ Display next page of the HOME menu

Pulling apart with two fingers



S19-0667

- ▶ Enlarge image
- ▶ Zoom into the map

Pulling together with two fingers



S19-0668

- ▶ Minimize image
- ▶ Zoom out of the map

Turn two fingers



S19-0666

- ▶ Rotate image
- ▶ Rotate the map

Contactless gesture control

The Infotainment menus marked with the  symbol can be controlled by hand gestures.



S19-0663

- ▶ Gesture control is achieved by slowly moving the hand back and forth approximately 8 cm above the lower edge of the screen.

Depending on the setting, a recognized gesture can be confirmed acoustically and animated.

Displaying operation help

- ▶ Tap on MENU >  > .

Settings

The following basic screen functions are set in the menu MENU >  > Screen:

- ▶ Brightness level of the screen
- ▶ Switch off the screen

- ▶ Display the time
- ▶ Confirmation sounds and animations

Infotainment keyboard

Keypad overview

The arrangement of the keyboard characters depends on the set infotainment language.

Depending on the context, the following types are used in infotainment:



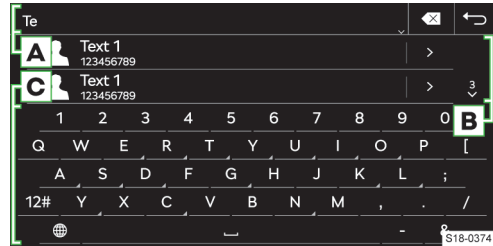

- ▶ Alphanumeric
- ▶ Numeric
- ▶ Keyboard for input
- ▶ Keyboard for search



S18-0374

Keypad example











A Input line



- ▶  Delete characters before the cursor
- ▶ **Tap:** delete the last character
- ▶ **Hold:** delete all characters one after the other
- ▶  Display functional surfaces for moving the cursor in the input line
 - ▶  Move cursor to the left
 - ▶  Move cursor to the right

B Entries found

- ▶  Show list

C Keypad functional surfaces



- ▶  Change to lowercase
- ▶  Switch to first having an upper-case letter, followed by lower-case letters
- ▶  Switch to uppercase
- ▶  Switch to the language keypad
- ▶  Switch to the numeric and character keypad
- ▶  Switch to other character variants
- ▶  Show additional keyboard languages
- ▶  Insert spaces
- ▶  The next line
- ▶  **Hold:** Show more character variants

- ▶  Show password
- ▶  Confirm the entered characters

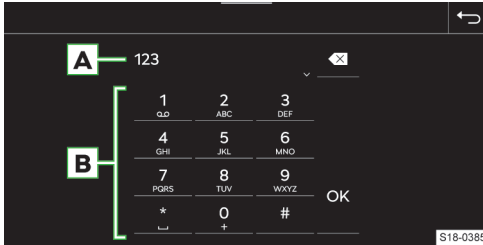
Numeric keypad



Keypad example

- A** Input line
 - ▶  Delete characters before the cursor
 - ▶ **Tap:** delete the last character
 - ▶ **Hold:** delete all characters
- B** Keypad functional surfaces
 - ▶  Confirm the entered characters

I If it is possible depending on the context, alphanumeric characters can be entered by holding a function area with the number.

Operation

The Infotainment keypad is used to enter characters, letters and numbers.

The keypad will be **automatically displayed** when Infotainment prompts for characters.

Find

When entering characters, corresponding entries are searched for.

The entry to be searched for can be entered including diacritics.

The keyboard will only provide characters that match the stored entries.

- › To **display searched entries** tap .

Show additional keypad languages

To use the additional keypad languages, the desired languages must be set first.

- › Tap  or repeatedly tap the flag symbol until the desired language keypad is displayed.

Further character variants

- › Press and hold the sign with the symbol .
- › Select the desired symbol.

Setting up additional keyboard languages

- › Tap **MENU** >  > *Additional keypad languages*.

Voice control

Functionality

Voice control principle

Voice control works according to the principle of dialogue between the user and the Infotainment system.

The user says a voice command. The Infotainment system responds or executes the voice command.

Advanced voice control

The vehicle's advanced voice control enables the vehicle functions to be searched and operated online.

Advanced voice control understands fluent whole sentences. You do not need to use set commands or phrases.

The advanced voice control can, for example, search for special destinations or dictate SMS messages if the connected telephone makes this possible.

This function allows you to combine the search in the online and offline data of the Infotainment. The transition between online and offline search is seamless and imperceptible to the user.

Operating conditions

- ✓ Ignition on
- ✓ Infotainment switched on

Operating conditions for advanced voice control

To use the advanced voice control, the following conditions must also be met:

- ✓ The vehicle supports the function.
- ✓ The vehicle has Infotainment and functions that can be controlled by the advanced voice control.
- ✓ The ŠKODA Connect services are active.
- ✓ The vehicle is within range of a contractual mobile network, through which the connection to ŠKODA Connect Services is ensured.
- ✓ The level of protection of personal data is set to  *Share my position*.

Requirement for recognition of the activation command

- ✓ Activated menu item **MENU** >  > *Voice control* > *Active*

Operation

Switch on voice control

- › Press the  button on the multifunction steering wheel.

Or:

- > Say the activation command "OK Laura".

After switching on, the icon  is displayed in the status bar.

Enter voice command

- > Speak a voice command with voice control switched on.

During recognition of the voice command, the  icon is displayed.

The Infotainment system then executes the voice command or plays the message. During the message, the  icon is displayed.

After the execution of the voice command, voice control is switched off.

Correcting a voice command

- > During voice command input, press the  button on the multifunction steering wheel and say a new voice command.

Stopping voice control

Stopping leaves more time for voice command input, e.g. for searching for a phone contact.

- > Move your finger up or down over the Infotainment screen.

Or:

- > Say the voice command "pause".

Resuming stopped voice control

- > Press the  button on the multifunction steering wheel.

Or:

- > Tap on  in the Infotainment screen.

Stopping the played back message

- > Press the  button on the multifunction steering wheel.

Ending voice control

- > Press the  button on the multifunction steering wheel twice.

Or:

- > Say the voice command "cancel" during voice command input.

Restriction

For some Infotainment languages, there is no voice control available. The Infotainment system will indicate this.

The messages are generated by Infotainment. Flawless clarity (e.g. road or city name) cannot always be guaranteed.

You cannot use voice control while a phone call is in progress.

Settings

The following voice control functions are set in the menu **MENU** >  > *Voice control*:

- ▶ Confirmation tones
- ▶ Enable/disable use of the activation word.

Self help

Starting acoustic help

- > If the Infotainment system is expecting a voice command, say "Help".

The "Help" voice command can be issued repeatedly for further tips on voice control.

Displaying the help

- > Tap on **MENU** >  > .

Or:

- > If Infotainment is expecting a voice command, say "Overview".

Switch example voice commands display on / off

The system offers the option of displaying example voice commands after switching on the voice control in the Infotainment screen.

- > To **turn MENU** >  > *voice control on/off*, tap > *Show in Infotainment system*.

Control centre

Overview

Display of the control centre



- > Press the bar at the top of the screen and drag down.

Closing the control centre

- > Tap on .

Or:

- > Wait 5 seconds.

Control Centre

The Infotainment control centre can be used for quick access to the following functions:

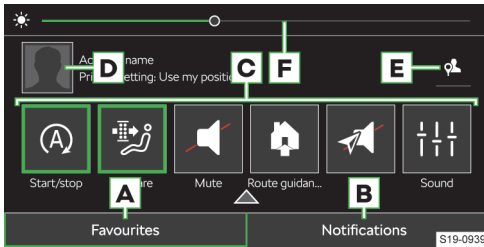

- A** Display and administration of functional surfaces of preferred features
- B** Display list of informational messages
- C** Preferred functions
- D** Display user account management
- E** Setting the personal data protection level
- F** Setting the instrument and key illumination

Set functional areas of preferred features

- > To **display** editing mode hold any function surface of the preferred feature.
- > To **add** the preferred feature, move the desired feature from the top of the screen to the functional surface at the bottom of the screen.
- > To **close** edit mode, tap on ×.

Radio

Overview

Display menu

- > Tap **RADIO**.
- Or:
- > Tap **MENU** >

Analogue and digital radio player

- > **A** Tap and select the desired frequency range.
- > Tap and search for or select the desired station.
- > Tap on .

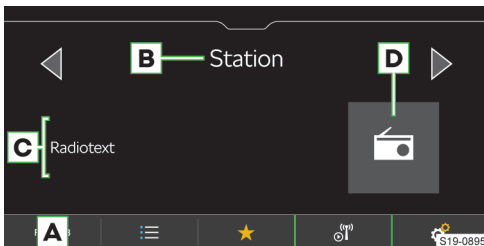

- A** Select source
- B** Station name

C Information about the broadcast content

D Station logos

List of available stations

★ Show favourites

Information about the station

Search stations manually (valid for AM and FM)

Settings

List of available analogue and digital radio stations

> Tap on .

Played station

★ Station stored on the presets

TP A traffic radio station is set

The DAB transmitter emits images which are displayed in the information to the station

Manual update of the station list

In the station list, information about the programme type and the channel identification of the regional channel can be displayed.

Web radio player

> **A** tap and select a web radio station.

> Tap and search or select web radio.

> Tap on .

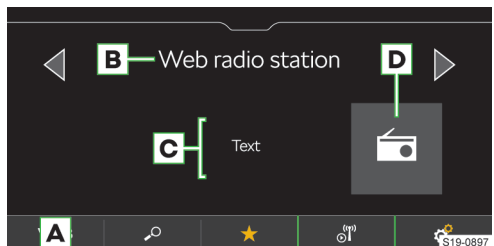

A Select source

B Station name

C Information about the broadcast content

D Station logos

List of web radio and podcasts

★ Show favourites

Information about the programme as well as the broadcast content of the web radio

Settings

Podcast player

> Tap **A** and select an online radio station.

> Tap and search for or select the desired podcast.

> Tap .



- A** Select source
- B** Podcast name
- C** Information about the broadcast content
- D** Podcast logo with the symbol

- ▶ **Tap:** Start playback
- ⏸ **Tap:** Pause
- ◀◀ **Tap:** Go back 15 secs
- ▶▶ **Tap:** Go forward 15 secs
- View episodes of the podcast being played
- List of web radio stations and podcasts
- ★ Show favourites
- Show information about the podcast
- Settings

List of web radio stations and podcasts

▶ Tap on .



- Search for web radio stations and podcasts
- Recently played web radio stations and podcasts
- 100 most popular web radio stations depending on the Infotainment language that has been set
- Go to podcasts and select
- Search for and select web radio stations and podcasts based on the selected country
- Search for and select web radio stations and podcasts based on the selected language
- Search for and select web radio stations and podcasts based on the selected genre
- See list of related podcasts based on content listened to

See list of related podcasts based on content listened to

The podcasts are shown in the displayed lists with the icon .

List of favourite stations and podcasts

▶ In the menu Radio, tap on ★.

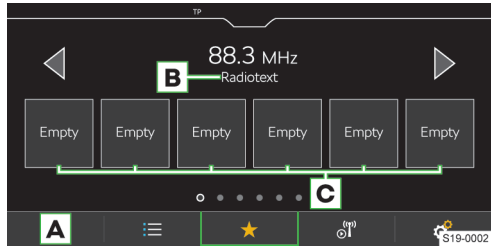

- A** Select source
- B** Radio text
- C** Station buttons for favourite stations and podcasts

Operation

Select station

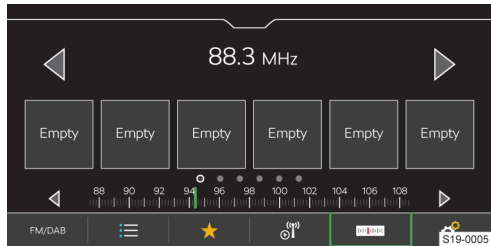

▶ Tap or at the top of the screen.

SCAN function

The function plays receivable stations of the selected frequency range in succession for a few seconds each.

- ▶ To **start automatic play** ▶, tap Scan.
- ▶ To **stop automatic play**, tap .

Find stations manually

Manual search is available for AM and FM stations.

- ▶ To display the functional surface for the FM station, turn on menu item > Advanced settings > Station display: > FM switch on
- ▶ In the Radio main menu, tap .
- ▶ To **search in sequence**, tap or next to the displayed frequency range scale.

Or:

- › Hold down the scroll mark on the frequency range scale and move it to the desired value.

Limitation

- ▶ Infotainment supports digital radio reception in DAB and DAB+ formats.
- ▶ Car parks, tunnels, tall buildings or mountains can restrict radio reception.
- ▶ In the rear side windows, there are antennas for receiving the radio signal.

Covering the panes with foils or metal-coated labels may affect the reception of the radio signal.

- ▶ The ŠKODA AUTO company assumes no responsibility for the availability, correct functioning and broadcast information of the RDS service.

Settings

Save the station currently being listened to as a favourite from the Radio main menu

- › Hold the desired station key for preferred stations until the station is stored.

Save station to favourites from the list of available stations

Applies to AM, FM and DAB frequency ranges.

- › Hold the line with the name of the desired station.
- › Tap the desired preset button.

Save channels from the list of web radio stations and podcasts

Valid for web radio stations and podcasts

- › Select a web radio station as the playback source.
- › Tap on .
- › Go to the desired web radio station or podcast and select it.
- › Hold the line with the name of the desired station or podcast.
- › Tap the desired preset button.

 With podcasts, it is not possible to save the individual episodes.

Deleting favourites

- › In the menu **Radio**  › *Delete memory entries* .
- › To delete a station button for preferred stations, tap the desired station button and confirm the deletion.
- › To delete all station buttons for preferred stations *Clear all* and confirm the deletion.

Functional surfaces for analogue and digital radios

Applies to AM, FM and DAB frequency ranges.

The variant for **changing stations** using the function surface   in the **Radio** menu is set as follows:

- › In the menu **Radio**  › *Arrow buttons* .
- › Select the variant for switching between the stations stored on the station buttons or the stations stored in the list of available stations.

Functional areas for web radio stations and podcasts

Applies to web radio stations and podcasts.

The variant for **changing stations** using the function surface   in the **Radio** menu is set as follows:

- › In the menu **Radio**  › *Arrow buttons* .
- › Select the variant for switching between the stations stored on the station keys or the last web stations and podcasts listened to.

Switch traffic reception (TP) for stations on/off

Applies to FM and DAB frequency range.

- › In the menu **Radio**  › *Traffic program (TP)* .

Assign station logo from the Infotainment memory

Applies to the FM and DAB frequency ranges.

Infotainment offers the option of assigning logos, which are stored in the Infotainment memory, to the stations.

- › In the menu **Radio**  › *Station logos* .
- › Select the desired station and logo.

Switching off the station logo display

Applies to the FM and DAB frequency ranges.

- › In the menu **Radio**  › *Station logos* .
- › To select the desired station. *No station logo* .

Activating / deactivating automatic station logo assignment

Applies to the FM and DAB frequency ranges.

When the function is switched on, a station logo from the Infotainment memory is assigned when the station is stored on a preset.

- › In the menu **Radio**  › *Advanced settings* › *Tap Automatic selection of station logos* .

Turn on/off radio text reception

Applies to the FM and DAB frequency ranges.

When the function is switched on and the station buttons are displayed, you can see more information about the content broadcast from the station to which you are listening.

- › In the menu **Radio**  › *Radio text* .

Regional FM station logo

Applies to the FM frequency range.

Infotainment provides the option of using country-specific FM station logos.

- > In the menu **Radio**  > *Advanced settings* > *Region for station logo* .
- > Choose country.

Switching additional announcements of the DAB transmitter on / off

Applies to the DAB frequency range.

When the function is switched on, other announcements are received as traffic announcements. These include e.g. weather news, sports reports, financial news etc.

- > In the menu **Radio**  > *Advanced settings* > *Tap Additional DAB announcements* .

Switch RDS on/off

Applies to the FM frequency range.

The menu item is only available for some countries.

- > In the menu **Radio**  > *Advanced settings* > *Radio Radio Data System (RDS)* .

If the **RDS function is disabled**, the following menu items in **FM station** settings are not available:

- ▶ Traffic program (TP)
- ▶ Radio text
- ▶ RDS Regional
- ▶ Automatic frequency change (AF)
- ▶ Regional station logo.

Switch automatic switching to a similar DAB transmitter on / off

Applies to the DAB frequency range.

When the function is switched on and there is signal loss from the DAB station being listened to, Infotainment automatically sets another DAB station with similar content.

- > In the menu **Radio**  > *Advanced settings* > *Tap Switch to a similar station if weak reception* .

Displaying FM / DAB stations or FM stations in the list of available stations

Applies to the FM and DAB frequency ranges.

Depending on the following setting, the stations of the selected frequency range are displayed in the list of available stations.

- > In the menu **Radio**  > *Advanced settings* > *Station display* : .
- > Select one of the following menu items:
 - ▶ *FM/DAB* - the list shows available FM and DAB stations.
 - ▶ *FM* - the list shows available FM stations.

Sound quality of web radio stations and podcasts

Applies to web radio stations and podcasts.

- > To adjust the sound quality, in the **Radio** menu tap on  > *Audio quality* : .
- > Choose low or high quality.

The quality you set affects the amount of data used in the data connection.

Quality also depends on the speed and availability of the data connection.

- ▢ If playback failure occur, reduce the sound quality.

Media

What you should be mindful of

- ▶ Do not save any important data or that which has not been backed up on the connected audio sources. ŠKODA assumes no responsibility for lost or damaged files or connected audio sources.
- ▶ When changing or connecting an audio source, this may cause sudden changes in volume. Reduce the volume before changing or connecting an audio source.
- ▶ When connecting an audio source, the source information messages can be displayed. These messages must be observed and, if necessary, confirmed.
- ▶ The national copyright laws that apply in your country must be observed.





Overview

Display menu

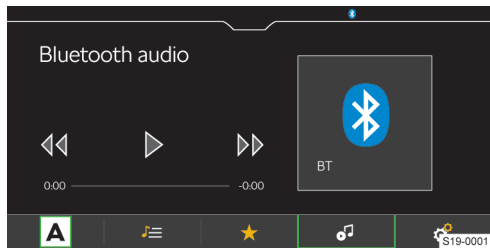
- > Tap **MEDIA**.
- Or:
- > Tap **MENU** >  .

Music player



- A** Choose source
-  Manage files / multimedia database
-  Show favourites
-  Details about the track being played
-  Settings

Video player

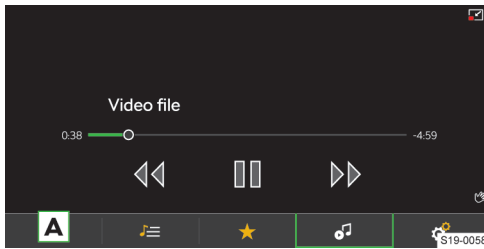

- A** Select source
- ☰ Manage files / multimedia database
- ★ Show favourites
- 📺 Show video
- ☐ Shrink image display
- ☐ Enlarge the image display
- ⚙ Settings

Player controls

Operation - Basics

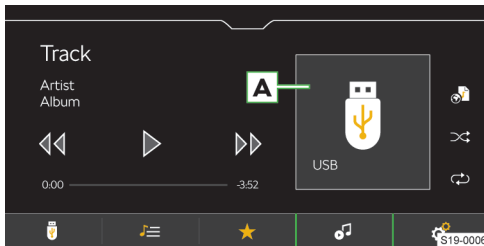

- A** Album image / symbol of the connected source
 - ▶ **Tap:** list available albums
- ▶ **Tap:** Start playback
- ⏸ **Tap:** Pause
- ⏮ **Within 3 seconds of starting playback, tap:** play the previous song
- ⏮ **After 3 seconds from the start of playback, tap:** to play the current title from the beginning
- ⏮ **Hold:** fast rewind within the track
- ▶▶ **Tap:** play the next track
- ▶▶ **Hold:** fast forward within the track

Movement within the title is also possible by dragging the finger over the timeline.

Advanced operation

- ↺ Turn on / off repeat playback of the current track

- ↺ Turn on / off repeat playback of the current album / folder
- ⌘ Turn on / off random playback of the current album / folder
- 📌 Save the played track in the "My playlist" playlist

"My playlist" management

- ▶ To display the playlist, tap ☰ > 📺 > 📌.
- ▶ To manage the playlist tap / in the displayed playlist.

The following activities can be carried out in playlist management:

- ▶ Control playback.
- ▶ Change the order of a title in the list by holding and moving ☰ to the desired position.
- ▶ Delete title.

Restriction

The availability of some media operation functions is dependent on the connected source and the software being used, e.g. Bluetooth®.

Settings

Manage favourites

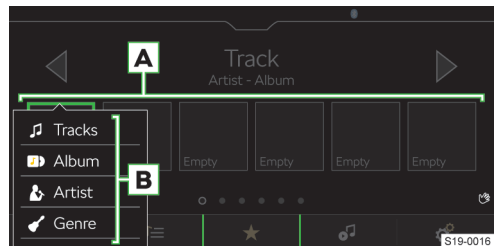

- › To save, hold the desired functional area for favourites **A**.
- › Choose one of the available list entries **B**.
- › To Clear, in the menu **media** ⚙ > tap on *Manage favourites*.
- › To delete a favourite, tap on the list entry and confirm the deletion.

Or:

- › To delete all favourites tap on *Clear all* and confirm the deletion.

Traffic

- › To turn on/off traffic monitoring during playback of media files, go to the **Media** in the main menu ⚙ > and tap on *Traffic program (TP)*.

Supported sources and files

Supported sources

Source	Interface	Type	Specification	File system
USB	USB 1.x; 2.x 3.x or higher with USB 2.x support	MSC	USB stick	VFAT FAT16 FAT32 exFAT NTFS
			HDD (without special software)	
		USB devices that use the USB mass storage support protocol		
		MTP	Devices running the Android or Windows Phone operating system that support the Media Transfer Protocol	
		Apple	Devices with the iOS operating system and the iAP2 protocol	HFS+
Bluetooth® player	Bluetooth®	-	Bluetooth® protocols A2DP and AVRCP (1.0 - 1.6)	-

Compatibility of mobile devices

It is possible to check the ŠKODAweb pages to see if Infotainment is compatible with the selected mobile device being tested. This check is carried out by using the following reference or by reading the QR code:

<http://go.skoda.eu/compatibility>



All information given is incidental and serves as information.

The ŠKODA AUTO company cannot guarantee full functionality and compatibility, e.g. due to a software update of the Infotainment and the mobile devices.

Supported audio files

Compression format	Codec type	File extension	Max. bit rate [kbps]	Max. sampling rate [kHz]	Multi channels
MPEG	MPEG 1 Layer 2	mp2	32 - 384	32, 44, 48	Mono, stereo, Joint stereo
	MPEG 2 Layer 2		8 - 160	16, 22, 24	
	MPEG 1 Layer 3	mp3	32 - 320	32, 44, 48	Mono, dual mono, Stereo, Joint Stereo
	MPEG 2 Layer 3		8 - 160	16, 22, 24	
	MPEG 2.5 Layer 3			8, 11, 12	

Compression format	Codec type	File extension	Max. bit rate [kbps]	Max. sampling rate [kHz]	Multi channels
WMA	Windows Media Audio 7	wma	6 - 192	8, 16, 22, 32, 44, 48, 96	Mono, stereo, Joint stereo
	Windows Media Audio 8		8 - 384		
	Windows Media Audio 9 and 9.1		8 - 768		
	Windows Media Audio 9.2		8 - 320		
	Windows Media Audio 10		32 - 768	32, 44, 48, 96	
ADTS	AAC LC	aac	16 - 2048	22, 24, 32, 44, 48	Stereo
	AAC HE			16, 22, 24, 32, 44, 48	
	AAC HEv2				
MP4	M4A LC	m4a	16 - 400	22, 24, 32, 44, 48	Stereo
	M4A HE			16, 22, 24, 32, 44, 48	
	M4A HEv2		16 - 64		
OGG	OGG-Vorbis	ogg	8 - 576	8, 11, 12, 16, 22, 24, 32, 44, 48, 96	Mono, Stereo
FLAC	FLAC	flac	-	8, 11, 12, 16, 22, 24, 32, 44, 48, 64, 88, 96, 192	Mono, stereo, Joint stereo
RIFF	WAV	wav	64 - 3072	8, 11, 12, 16, 22, 24, 32, 44, 48, 96	Mono, Stereo
Monkey's	Monkey's	ape	8 - 192		
SBC	Bluetooth A2DP	-	8 - 345	8, 11, 12, 16, 22, 24, 32, 44, 48	Mono, stereo, Joint stereo
OPUS	OPUS	opus	6 - 2000	8 - 48	Mono, stereo, Multichannel

Files that are protected by **DRM-** and **iTunes®** methods are not supported by Infotainment.

Supported video files

Codec type	File extension	Max. recordings per second bit rate [Mbit/s]
MPEG 1	mpg mpeg m1v mPV	1.5
MPEG 2	mpg mpeg ps m2v	15
MPEG 4 (H.264)	m4p mp4 m4v mp4v mov	50
MPJEG		
MPEG 4 (ISO)		
Xvid	Xvid	20

Codec type	File extension	Max. recordings per second bit rate [Mbit/s]
WMV9	wmv asf	50

Supported playlists

Codec type	File extension
M3U	m3u
M3U8	m3u8
PLS	pls
WPL	wpl
ASX	asx

Images

Overview

Display menu

> Tap MENU >

Image viewer

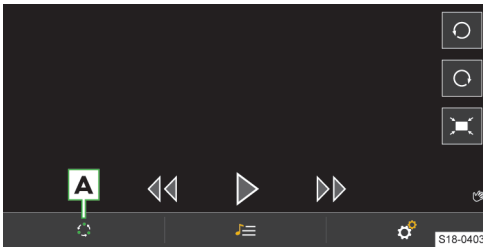

A Select source

Manage files

Settings

Operation

Operation using functional areas

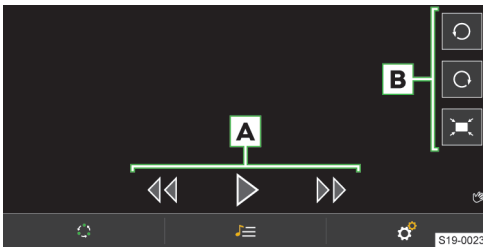

A View images

- ▶ Show the next image
- ▶ Show the previous image
- ▶ Start slideshow

▶ Stop slideshow

B View image

- ▶ Turn left
- ▶ Turn right
- ▶ Show in output size

Gesture control



▶ Display of the next image

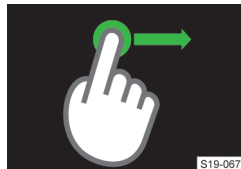

▶ Display the previous image



▶ Increase the image size



▶ Reduce the image size



▶ Rotate by 90 °

Settings

The following Infotainment functions are set in the MENU > > menu:

- ▶ Display image size
- ▶ Display image duration during the slideshow
- ▶ Slideshow repeat

Supported sources and files

Supported sources

Source	Interface	Specifica- tion	File system
USB	USB 1.x; 2.x 3.x or higher with USB 2.x support	USB stick	VFAT
		HDD (without special software)	FAT16 FAT32 exFAT NTFS

Supported files

Codec type	File extension	Max. resolution [Mpx]
BMP	bmp	4
JPG; JPEG	jpg; jpeg	4 (Progressive Mode) 64
GIF	gif	4
PNG	png	4

The maximum supported image size is 20 MB.

Mobile device management

Cybernetic security

Your vehicle contains components that are used to exchange information and data between the vehicle and the connected mobile devices or the Internet.

These components have security mechanisms that minimise the risk of unauthorised access to the vehicle systems.

Regular software updates help reduce the risk of unauthorised access to vehicle systems and vehicle functions. The following guidelines must therefore be observed:

- ▶ Use only media carriers, Bluetooth® devices, and mobile devices that contain no harmful data or malware.
- ▶ Regularly update the software provided by ŠKODA AUTO.

We recommend having the system software and components updated by a specialist company.

⚠ WARNING

Risk of an accident!

Malware in the vehicle can influence and deactivate certain vehicle functions, or take over the controls of these where applicable.

- ▶ If the vehicle reacts in an unusual way, immediately reduce speed or stop the vehicle.
- ▶ Seek the help of a specialist garage.

⚠ WARNING

Malware in the vehicle may gain unauthorised access to the information and data of the vehicle, and on occasion, to connected mobile devices.

Overview

Using mobile device management, devices can be connected, disconnected, and interchanged.

Display mobile device management

- ▶ Tap on MENU > > Manage mobile devices.

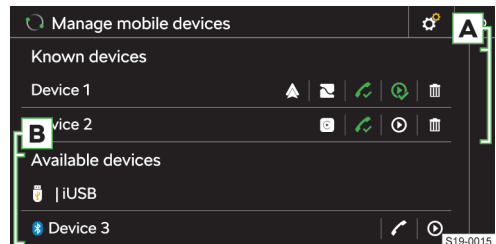

- ✔ The device enables a connection via the Bluetooth® "hands-free profile"
- ✔ The device is connected via the Bluetooth® "hands-free profile"
- ⊙ The device enables a connection via the Bluetooth® audio profile
- 🔊 The device is connected via the Bluetooth® audio profile
- 🗑 Remove the device from the list **previously connected devices**
- ▲ The device enables a SmartLink connection to be made via Android Auto
- The device enables a SmartLink connection to be made via Apple CarPlay
- 📺 The device enables a SmartLink connection to be made via MirrorLink

A Connected / Previously connected devices

B Available devices

Limitations of mobile devices and applications

Availability of features

The availability of certain features depends on the type of mobile device, as well as that of the applications installed.

Compatibility of mobile devices

It is possible to check the ŠKODAweb pages to see if Infotainment is compatible with the selected mobile device being tested. This check is carried out by using the following reference or by reading the QR code:

<http://go.skoda.eu/compatibility>



All information given is incidental and serves as information.

The ŠKODA AUTO company cannot guarantee full functionality and compatibility, e.g. due to a software update of the Infotainment and the mobile devices.

Bluetooth® compatibility of mobile devices

Due to the large number of mobile devices, it is not possible to guarantee total Bluetooth® compatibility with Infotainment. Bluetooth® compatibility depends on the Bluetooth® version as well as the implementation of Bluetooth® protocols by the manufacturer of the mobile device.

Applications in mobile devices

Mobile devices can be used to install applications that allow you to view additional information on the Infotainment screen, or to operate the Infotainment system.

Due to the variety of applications, as well as their ongoing development, the available applications may not function on all mobile devices. ŠKODA AUTO assumes no liability for their proper functioning.

The scope of available applications and their functionality is dependent on the type of Infotainment, as well as the vehicle and country.

Information about ŠKODA applications

Detailed information about ŠKODA applications can be found on the website after reading the following QR code or link:

<http://go.skoda.eu/mobile-apps>



Connection set-up

Connect a mobile device to Infotainment

- › Find available Bluetooth® devices in the mobile device.
- › Select the Infotainment Bluetooth® unit.

The unit name can be determined by tapping **MENU** › › *Manage mobile devices* › › *device name*.

- › Confirm the PIN; enter it if necessary and then confirm.

Connect Infotainment to a non-paired mobile device

- › **MENU** › › *Manage mobile devices* .
- › Select the desired device from the list of **available devices**.
- › Select the desired Bluetooth® profile.
- › Confirm the PIN; enter it if necessary and then confirm.
- › If two devices are connected to the Infotainment, select the device to be replaced.

Connect Infotainment to a previously connected mobile device

- › **MENU** › › *Manage mobile devices* .

Or:

- › **PHONE** › › *Select mobile phone* .
- › Select the desired device from the list of **previously connected devices**.
- › Select the desired Bluetooth® profile.
- › If two devices are connected to the Infotainment, select the device to be replaced.

SmartLink connection

Infotainment provides the ability to connect SmartLink to compatible mobile devices using the following connection types:

- ▲ Android Auto
- 📱 Apple CarPlay
- 📺 MirrorLink

Mobile devices can be connected to the Infotainment via USB cable or Wi-Fi, as long as the mobile device supports it.

- › Connect the mobile device to the Infotainment via a USB cable or browse and connect to a wireless network.
- › Tap the icon of the supported connection.

Telephone

Overview

Display menu

- › Tap **PHONE**.

Or:

> Tap **MENU** > ⌵.

i If the menu **phone** is not displayed, check whether the mobile device is connected.

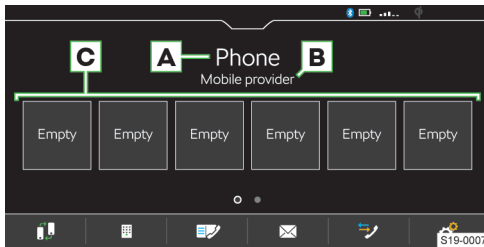

- A** Name of the connected telephone
 - ▶ **Tap:** Show list of previously connected phones
- B** Name of telephone service providers
 - ▶ If the symbol ▶ is displayed in front of the name, roaming is active.
- C** Preset buttons for preferred contacts
 - 📞 Change the main telephone with the additional telephone
 - ☎ Enter telephone number
 - 📞 Contact list
 - ✉ Text messages / emails
 - 📞 Call lists
 - ⚙ Settings

Conditions for connecting a telephone with Infotainment

- ✓ The Bluetooth® function of the Infotainment and the telephone needs to be switched on.

The Bluetooth® function of the Infotainment is switched on in the menu item **MENU** > ⌵ > *Manage mobile devices* > ⌵ > *Bluetooth*.
- ✓ Visibility of the Infotainment is switched on.

The visibility of the Infotainment is switched on in the menu item **MENU** > ⌵ > *Manage mobile devices* > ⌵ > *Visibility*.
- ✓ The telephone is within signal range of the Infotainment's Bluetooth® unit.
- ✓ The telephone is compatible with Infotainment.

Telephone operation

Enter telephone number

- > In the **Phone** menu, tap on ☎.
 - > Enter the telephone number using the numeric keypad that is displayed.
- i** The displayed numeric keypad can also be used for searching for contacts.

If, for example, the digits 32 are entered, contacts with the letter sequence DA, FA, EB etc. are displayed next to the numeric keypad.

List of telephone contacts

The list of telephone contacts is imported from the connected main telephone.

- > To **display** the contact list in the **phone** menu, tap on ☎.
- > To **search** within the list, tap on *Enter contact*.
- > Enter the details you wish to find.
- > To **establish a connection** with a contact, tap the functional area showing the desired contact.

If a contact has multiple telephone numbers, select the telephone number from the displayed list.

- > To display the **details** for a contact, tap >.

Establish a connection to the voice mailbox number

- > In the **Phone** menu, tap on ☎ > 00.

Telephone conversation

Depending on the context of the telephone conversation, the following functions can be selected:

- 🔴 End connection / reject incoming call / end call
- 🟢 Answer an incoming call / return to the held call
- 🔊/🔇 Switch the ringer off / on
- 👤 Hold a call
- 🔇/🔊 Switch the microphone off / on
- 👤 Show details of the caller
- ✉ Reject an incoming call using an SMS message
- 📞 Answer a call from the second telephone during a call on the first telephone

The ongoing call on the first telephone is terminated by accepting the call.

- > To **switch the call tone from the speakers to the telephone**, go to **telephone** in the menu and tap on ☎ > *speakerphone*.
- > To **switch the call tone from the telephone to the speakers**, tap 📞.

Conference call

A conference call is a joint telephone conversation with a minimum of three and a maximum of six participants.

- > Make the next call during an ongoing conversation/conference.

Or:

- > Accept a new incoming call by tapping 🟢.
- > To **start** a conference call, tap 📞.

During an ongoing conference call, the following functions can be selected depending on the context:

- 👤 Hold the conference call and leave temporarily (the conference will continue in the background)
- 🟢 Return to the held conference call

- 🔇/🔊 Switch the microphone off / on
- 📞 End conference call
- 👤 Show details of the conference call

In the details of the conference call, depending on the connected telephone, the following functions can be selected:

- 👤 Show details of the conference call participants
- 📞 End conversation with the conference call participant
- 👤📞 Conversation with a participant outside of the conference call

Send a text message

- In the **Telephone** ☒ > ☒ menu, tap *Messages* > 📧 *New SMS* .
- Write a text message and confirm; a view of the message is displayed.
The message can be edited when the text area within the view is tapped.
- Search for or select the recipient of the message.
- Add more recipients or confirm selected recipients.
- Tap on *Send* .

Display received text messages

- In the **Telephone** ☒ > ☒ menu, tap *Messages* > ☒ or ☒.
- Messages that are received are displayed as individual messages or as messages in a conversation, depending on the following setting.
To **switch the display of messages in a conversation on or off**, tap in the **Phone** 📞 > menu *Show messages as conversation* .
- To **switch graphic notifications** regarding the receipt of a new message **on or off**, tap in the **Phone** 📞 > menu *New message notifications* .

📄 Infotainment offers the possibility to read the text message (context-dependent) by means of the generated Infotainment voice if 🗣️ is tapped.

Send e-mails

- In the **Telephone** ☒ > ☒ menu, tap *Emails* > 📧 *New emails* .
- Write an e-mail and confirm that an e-mail is displayed.
The text can be edited when the text area within the view is tapped.
- Search for or select the recipient of the email.
- Add more recipients or confirm selected recipients.
- Enter the subject of the e-mail.
- Tap on *Send* .

Show received e-mails

- In the **Telephone** ☒ > ☒ menu, tap *Emails* > ☒.

- Select the desired e-mail.
- To **switch graphic notifications** regarding the receipt of a new email **on or off**, tap in the **Phone** 📞 > menu *New message notifications* .

Settings for Infotainment telephone functions

Telephone-Infotainment-Connection types

The way in which the telephone is connected depends on the number of phones currently connected to the Infotainment:

- ▶ **No telephone** - The telephone is connected as a main telephone.
- ▶ **One telephone** - The telephone is connected as an additional telephone.
- ▶ **Two telephones** - Select the telephone to be replaced.
- To **switch between the main telephone and the additional telephone**, tap on 📞 in the **Phone** menu.

Connect the telephone to Infotainment

- Find available Bluetooth® devices on the phone.
- Select the Infotainment Bluetooth® unit.
The unit name can be determined by the menu item **MENU** > 📞 > *Manage mobile devices* > 📞 > *Device name*.
- Confirm the PIN; enter it if necessary and then confirm.

Connect Infotainment to a non-paired telephone - no telephone is connected

- Tap on **PHONE**.
- Or:
- Tap on **MENU** > 📞.
- Follow the instructions in the Infotainment screen.

Connecting Infotainment to a non-paired telephone - another telephone is connected

- Tap on **MENU** > 📞 > *Manage mobile devices*.
- Select the desired device from the list of **available devices**.
- Select the desired Bluetooth® profile.
- Confirm the PIN; enter it if necessary and then confirm.

The telephone is connected as an additional telephone.

- Or:
- If two telephones are connected to the Infotainment, select the telephone to be replaced.

Connect Infotainment to a previously paired telephone

- **MENU** > 📞 > *Manage mobile devices* .
- Or:

PHONE > > Select mobile phone .

- > Select the desired device from the list of **previously connected devices**.

The telephone is connected as an additional telephone.

Or:

- > If two telephones are connected to the Infotainment, select the telephone to be replaced.

Manage preset buttons for preferred contacts

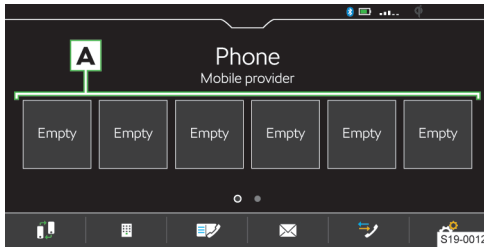

- > To **save** the desired preset button, hold **A**.
- > Select a contact from the displayed list.
- > If the contact contains multiple telephone numbers, choose the desired telephone number.
- > To **display the menu for deletion**, go to the **phone** menu > and tap on *Manage favourites* .
- > To delete **one** preset, tap on the list entry and confirm the deletion.

Or:

- > To delete **all** station buttons, tap *Clear all* and confirm the deletion.

Import telephone contacts

After first connecting the main telephone with Infotainment, telephone contacts will start to be imported into the Infotainment memory.

Infotainment can import up to 5000 telephone contacts together with contact pictures. Each contact can include max. 5 telephone numbers.

Depending on the type of telephone, import confirmation may be required.

Update telephone contacts

When re-connecting the telephone with Infotainment, an **automatic** update of the list is carried out.

- > For **manual** update of the list in the **phone** > menu tap on *Import contacts* .

Sort contacts in the phone book

- > In the **Telephone** > menu *Sort by*: Tap and select the sorting type.

Ringtone

Some phones do not allow the use of the telephone ringtone; instead, the Infotainment ringtone is used.

- > For **setting the Infotainment ringtone** in the **phone** > menu *select the ringtone* .
- > Select the ringtone.

Number for the voice mailbox

- > For **setting the voice mailbox number** in the **phone** > menu *Mailbox number*: .
- > Enter the voice mailbox number.

Turn the graphic notice regarding receiving a new message/email on or off

When the feature is on, the new message icon appears on the status bar and in the feature area for the messages when a new message/e-mail is received.

- > In the **Telephone** > menu *New message notifications* .

Simultaneous calls

This applies to some countries.

Depending on the connected telephone, it is possible to answer the next incoming call and hold the previous call.

- > To switch on simultaneous calls, tap on **telephone** > *Parallel talks*.

Wi-Fi

Overview of available hotspots

Display available hotspots

- > Tap **MENU** > > *Wi-Fi* > *Wi-Fi*.

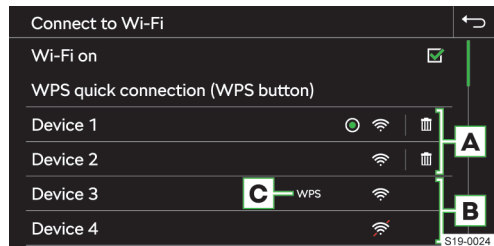

- A** Previously connected hotspots
- B** Available hotspots
- C** The hotspot supports the WPS connection
- Currently connected hotspot
- Delete information about the hotspot connection
- Wi-Fi signal strength of the hotspot
- The Wi-Fi signal from the hotspot is not available

Functionality

The Wi-Fi can be used for the internet connection or for the SmartLinkConnection.

The Infotainment hotspot can connect up to 8 mobile devices. At the same time, the Infotainment can be connected to another hotspot.

- ▶ To display the list of connected mobile devices, tap **MENU** >  > Wi-Fi > Infotainment system as hotspot > Connected devices.

Settings

Connect a mobile device to the Infotainment hotspot

- ▶ Turn on the Infotainment's Wi-Fi hotspot in the menu item **MENU** >  > Wi-Fi > Infotainment system as hotspot > Use as hotspot.
- ▶ Turn on the Wi-Fi on the mobile device.
- ▶ In the list of available Wi-Fi devices, look for Infotainment Wi-Fi.

The name of the Infotainment is taken from the menu item **MENU** >  > Wi-Fi > Infotainment system as hotspot > Network name..

- ▶ Select the Infotainment hotspot and enter the required password.

The password for connecting to the Infotainment hotspot is taken from the menu item **MENU** >  > Wi-Fi > Infotainment system as hotspot > Network key.

- ▶ Confirm the connection.

Connect Infotainment to the mobile device hotspot

- ▶ Turn on the Infotainment's Wi-Fi unit in the menu item **MENU** >  > Wi-Fi > WLAN: > WiFi active switch on
- ▶ Select the desired hotspot in the list of available hotspots.
- ▶ Enter the password for connecting to mobile devices.

 Infotainment stores passwords for previously connected hotspots.

Security level of the Infotainment hotspot

The security level is set at WPA2 and cannot be changed.

Activate/deactivate data transfer between the Infotainment and the connected device

- ▶ To turn data transmission on or off, tap **MENU** >  > Wi-Fi > Infotainment system as hotspot > Connected devices > .

Change the name of the Infotainment hotspot

- ▶ Tap **MENU** >  > Wi-Fi > Infotainment system as hotspot > Network name..

- ▶ Enter the name and confirm.

Change password for connection to Infotainment hotspot

The password must be a minimum of 12 and a maximum of 63 characters.

- ▶ **MENU** >  > Wi-Fi > Infotainment system as a hotspot > Network key .

- ▶ Enter and confirm the password.

Quick connection of Infotainment to the mobile device hotspot

- ▶ On the mobile device, turn on the hotspot, its visibility, and the option for WPS connection.
- ▶ **MENU** >  > Wi-Fi > Wi-Fi: Tap > WPS quick connection (WPS button).



Automatic WPS connection

- ▶ Tap **MENU** >  > Wi-Fi > Quick connection to Infotainment system.
- ▶ In the mobile device, switch on the option for connection via WPS.
- ▶ Wait for the connection to be established and, if necessary, confirm the respective messages.

Manual WPS connection

- ▶ In the mobile device, switch on the option for connection via WPS PIN.

The mobile device display will show the WPS PIN for connecting to the Infotainment.

- ▶ Tap **MENU** >  > Wi-Fi > Quick connection to Infotainment system >  > WPS PIN.
- ▶ Enter the WPS PIN in the Infotainment and confirm.
- ▶ Wait for the connection to be established and, if necessary, confirm the respective messages.

Automatic connection using the QR code

- ▶ **MENU** >  > Wi-Fi > Tap quick connection with infotainment system .
- ▶ In the mobile device, switch on the option for connection via QR Code.
- ▶ With the mobile device, read the QR code displayed on the Infotainment screen.
- ▶ Wait for the connection to be established and, if necessary, confirm the respective messages.

Tips for a perfect connection

-  Keep only the hotspot to be connected switched on and switch off the other hotspots.
- ▶ Delete unused hotspots. This shortens the time required to establish a connection.
- ▶ For some hotspots, the connection takes longer, so wait for the connection to finish.
- ▶ If the connection is interrupted, recheck the available hotspots and repeat the connection.

Function restriction

The Infotainment system can only be connected to a hotspot with WPA2 access protection.

Restriction of the Wi-Fi connection

In some countries, the Wi-Fi connection is restricted for legal reasons. When crossing the border of the country in question, the connection with a mobile device connected via Wi-Fi can be ended or restricted.

i Find out about country-specific legal restrictions. If necessary, switch off the Wi-Fi manually.

SmartLink

Functionality

SmartLink offers the ability to display and operate certified applications from a connected mobile device in the Infotainment screen.

Certification may be conditional upon the use of the latest update to the particular SmartLink application.

Applications include, for example, apps for route guidance, telephoning, listening to music, etc.

Mobile devices can be connected via a USB cable or WiFi.

Supported connection types

SmartLink supports the following connection types:

- ▶ Android Auto
- ▶ Apple CarPlay
- ▶ MirrorLink

Overview of the SmartLink connection

Menu SmartLink

> Tap **MENU** >

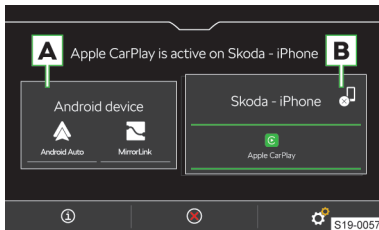

- A** Previously connected device
- B** Currently connection device
- Display information about SmartLink
- Disconnection of the active connection
- Disconnection of the active connection
- Settings in SmartLink menu

Android Auto

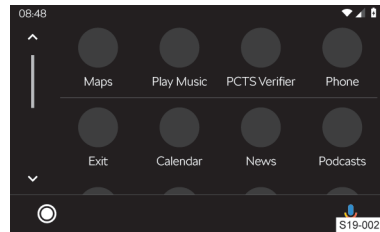

Overview of running applications, phone calls, incoming text messages, and more.

Turn on voice control (Google Voice)

Apple CarPlay

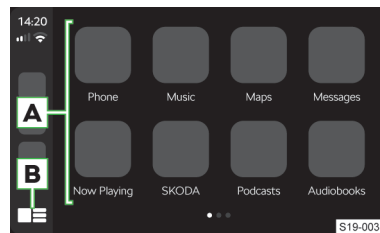

A List of available applications

B Depending on the duration of operation:

- ▶ **Tap:** Return to the menu Apple CarPlay
- ▶ **Hold:** Turn on voice control (Siri)

MirrorLink

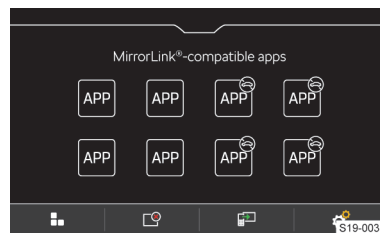

It is not possible to operate the application while driving

Return to the menu SmartLink

List of running applications

Display of the last running application in connected mobile devices

Settings

Connection conditions

General connection conditions

- ✓ The mobile device supports the type of SmartLink connection Android Auto, Apple CarPlay or MirrorLink.
- ✓ Mobile devices, as well as the type of SmartLink connection, are supported in the respective market.
- ✓ Some connected mobile devices require the mobile device to be “unlocked”.

Conditions for Android Auto

- ✓ The device to be connected must have Android Auto connection.

A list of devices, supported regions and applications that support the Android Auto connection can be found on the Google, Inc. website.

- ✓ The Android Auto application needs to be installed on the mobile device.
- ✓ Some applications require the data connection in the mobile device to be turned on.
- ✓ Connect the mobile device for the first time when the vehicle is stationary.

Conditions for Apple CarPlay

- ✓ The device to be connected must have Apple CarPlay connection.

A list of devices, supported regions and applications that support the Apple CarPlay connection can be found on the Apple Inc website.

- ✓ Siri voice control is on.
- ✓ The data connection in the mobile device is switched on.

Conditions for MirrorLink

- ✓ The device to be connected must have MirrorLink connection.

A list of devices and applications that support the MirrorLink connection can be found on the websites of Car Connectivity Consortium®.

- ✓ The MirrorLink application needs to be installed on the mobile device.
- ✓ Some applications require the data connection in the connected mobile device to be turned on.

Operation

Operation of the running MirrorLink application

- Display of control surfaces at the bottom
- Display of control surfaces at the top
- ☰ Return to the menu MirrorLink

Restriction

Restriction of the Wi-Fi connection

In some countries, the Wi-Fi connection is restricted for legal reasons. When crossing the border of the country in question, the connection with a mobile device connected via Wi-Fi can be ended or restricted.

- ℹ Find out about country-specific legal restrictions. If necessary, switch off the Wi-Fi manually.

Restriction of SmartLink applications while driving

For reasons of safety, the operation of some SmartLink applications while driving is not possible or only limited.

Restriction of the navigation function

If route guidance is currently being carried out through Infotainment, this is ended when you start route guidance in the Apple CarPlay application.



If there is route guidance in the Apple CarPlay application, it is ended by starting the destination guidance using Infotainment.

SmartLink settings

Apple CarPlay - Connection via USB

- › Turn on the Infotainment.
- › Turn on the mobile device.
- › Connect the mobile device to the front USB input using a cable.
- › Choose to connect via Apple CarPlay.

Apple CarPlay - Connection via Wi-Fi from Infotainment

- › Turn on Bluetooth® and Bluetooth® visibility in the Apple mobile device.
- › Tap on **MENU** >  > *Manage mobile devices*.
- › In the displayed list, look for and select the desired device with the symbol .
- › Follow the instructions on the Infotainment screen and confirm the Bluetooth® pairing.
- › If another device is connected to the Infotainment, select the device to be replaced.

Apple CarPlay - Connect via Wi-Fi from mobile devices

To establish a connection, the following conditions must be met:

- ✓ The minimum iOS version is 9.
- ✓ No other mobile device can be connected via SmartLink.
- ✓ Wi-Fi and Bluetooth® functionality is switched on in the Infotainment system.
- › In the mobile device, turn on the CarPlay function.
- › Press and hold the  button on the multifunction steering wheel.

The Infotainment screen displays a connection message with the name of the Bluetooth® unit of the Infotainment.

- › Find available Bluetooth® devices on the phone.
- › Select the Infotainment Bluetooth® unit.
- › If necessary, confirm the PIN.
- › In the Infotainment screen, select the connection type Apple CarPlay.



Apple CarPlay - Disconnect

- › In the Apple CarPlay menu, tap on the function area “ŠKODA”.
- › Tap on .

Android Auto - Connection via USB

- › Turn on the Infotainment.
- › Turn on the mobile device.
- › Connect the mobile device to the front USB input using a cable.
- › Choose to connect via Android Auto.

Android Auto - Connection via Wi-Fi from Infotainment



- › Tap on **MENU** ›  ›  › *mobile devices*.
- › Select the desired device from the list of **available devices**.
- › Select the Bluetooth® hands-free profile.
- › Confirm the PIN; enter it if necessary and then confirm.
- › If another device is connected to the Infotainment, select the device to be replaced.
- › From the list of **known devices**, select the desired device with the  symbol.

Android Auto - Connect via Wi-Fi from mobile devices

To establish a connection, the following conditions must be met:

- ✓ The minimum Android version is 5.
- ✓ No other mobile device can be connected via SmartLink.
- ✓ Wi-Fi and Bluetooth® functionality is switched on in the Infotainment system.
- › Find available Bluetooth® devices on the phone.
- › Select the Infotainment Bluetooth® unit.
- › If necessary, confirm the PIN.
- › In the Infotainment screen, select the connection type Android Auto.

Android Auto - Disconnect



- › In the Android Auto  › menu, tap “Return to ŠKODA”.
- › Tap on .

MirrorLink - Connection via USB

- › Turn on the Infotainment.
- › Turn on the mobile device.

- › Connect the mobile device to the front USB input using a cable.
- › Choose to connect through MirrorLink.

MirrorLink - Disconnect

- › In the MirrorLink menu, tap on .
- › Tap on .

Change to another device / connection type

Infotainment allows you to switch between currently connected devices and the connection type.

- › Tap on **MENU** › .
- › Select the desired device or connection type.

Infotainment Amundsen

Infotainment overview

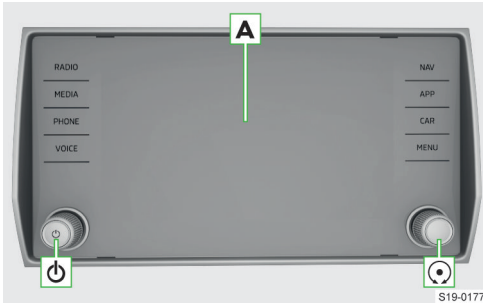

- A** Touchscreen
- ⏻ Control dial left
 - ▶ **Press:** Switch Infotainment on/off
 - ▶ **Turn:** Set volume
 - ⌚ Control dial right
 - ▶ **Press:** Confirm menu item
 - ▶ **Turn:** select menu item/set value

RADIO	Radio menu
MEDIA	Media menu
PHONE	Phone menu
VOICE	Voice control
NAV	Navigation menu
APP	SmartLink menu
CAR	Information about vehicle settings
MENU	Overview of Infotainment menus

System

Limitation

For safety reasons, operation of some Infotainment functions while driving is not possible or is restricted.

The Infotainment system indicates this by means of a message in the screen.

Basic settings

Setting basic functions

The following Infotainment functions are set in the **MENU** > ⚙️ menu:

- ▶ Time and date
- ▶ Language
- ▶ Units
- ▶ Restore factory settings

Sound settings

The Infotainment sound is set in the menu **MENU** > ⚙️.

The following menu items can be set:

- ▶ Setting the equalizer
- ▶ Adjusting the volume ratio
- ▶ Volume adjustment of individual Infotainment functions

The volume can be adjusted on e.g. one of the following menu items:

- ▶ Volume adjustment of voice commands
- ▶ Setting the maximum volume when Infotainment is turned on
- ▶ Speed-dependent volume setting
- ▶ Setting the Infotainment to mute with the parking aid switched on

Depending on the equipment, the following advanced sound settings can be set

- ▶ Setting space optimisation
- ▶ Setting the audio profiles according to genre
- ▶ Adjusting the subwoofer volume

Configuration wizard

The configuration wizard helps to set certain Infotainment functions.

The configuration assistant is automatically displayed if the ignition is switched on and if there are at least two menu items that have not been set up after switching on the Infotainment.

- › To **switch off the automatic display**, when the configuration assistant is displayed tap *Don't show again*.
- › For **manual display** tap **MENU** > ⚙️ > *Configuration wizard*.

Set up menu HOME

- › To **display another page** of the HOME menu, press the screen with two fingers and drag it to the left or right.

To **add the preferred menu**, proceed as follows:

- › Tap on an empty functional surface.

Or:

- › Press and hold an occupied functional surface and then tap on an empty functional area.
- › Select a menu with the desired dimension of the functional surface.
- › Tap on × to exit edit mode.

To **remove the preferred menu**, proceed as follows:

- › Press an occupied functional surface.
- › Tap on ⌫.
- › Tap on × to exit edit mode.

Set up menu MENU

The position of the functional surfaces in the MENU menu can be customized as follows:

- › Press and hold the desired functional surface until it is free.
- › Move the functional surface to a different position.

Troubleshooting

Infotainment not responding

If the infotainment does not respond, restart it as follows:

- › Hold ⏻ for longer than 10 s.
- › Wait for the restart to complete.

System update

We recommend having the system update carried out by a specialist company.

The system update ensures optimal function of the Infotainment system, e.g. compatibility with new phones.

Determine system version

- › Tap **MENU** > > System information.

Screen

Overview

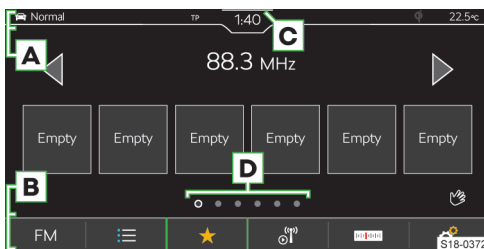

- A** Status bar
- B** Bar with the functional surfaces of the displayed menu
- C** Display of the control centre
- D** Other pages of the menu

Operation

⚠ NOTICE

Danger of screen damage!

- › The Infotainment screen is operated by **touching it lightly with your finger**.

In principle, operation by touch is identical to the operation of a mobile phone.

The following operating modes are specific to the Infotainment system.

Dragging up or down with two fingers

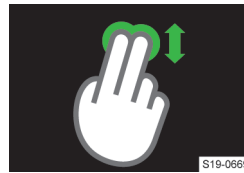

- › Quickly review the list of phone contacts
- › Switch 2D/3D map display

Dragging left or right with two fingers



- › Display next page of the HOME menu

Pulling apart with two fingers



- › Enlarge image
- › Zoom into the map

Pulling together with two fingers



- › Minimize image
- › Zoom out of the map

Turn two fingers



- › Rotate image
- › Rotate the map

Contactless gesture control

The Infotainment menus marked with the symbol can be controlled by hand gestures.



- › Gesture control is achieved by slowly moving the hand back and forth approximately 8 cm above the lower edge of the screen.

Depending on the setting, a recognized gesture can be confirmed acoustically and animated.

Displaying operation help

- ▶ Tap on MENU > ⓘ > 🗨.

Settings

The following basic screen functions are set in the menu MENU > ⚙ > Screen:

- ▶ Brightness level of the screen
- ▶ Switch off the screen
- ▶ Display the time
- ▶ Confirmation sounds and animations

Infotainment keyboard

Keypad overview

The arrangement of the keyboard characters depends on the set infotainment language.

Depending on the context, the following types are used in infotainment:

- ▶ Alphanumeric
- ▶ Numeric
- ▶ Keyboard for input
- ▶ Keyboard for search

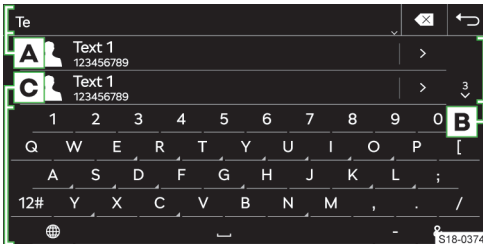

Keypad example

- A** Input line
 - ▶ ✖ Delete characters before the cursor
 - ▶ **Tap:** delete the last character
 - ▶ **Hold:** delete all characters one after the other
 - ▶ ∨ Display functional surfaces for moving the cursor in the input line
 - ▶ < Move cursor to the left
 - ▶ > Move cursor to the right
- B** Entries found
 - ▶ ∨ Show list
- C** Keypad functional surfaces
 - ▶ ↕ Change to lowercase
 - ▶ ⌂ Switch to first having an upper-case letter, followed by lower-case letters
 - ▶ ⬆ Switch to uppercase

- ▶ **ABC/ABB** Switch to the language keypad
- ▶ **12#** Switch to the numeric and character keypad
- ▶ **1/2/2/2** Switch to other character variants
- ▶ 🌐 Show additional keyboard languages
- ▶ ⌵ Insert spaces
- ▶ ↵ The next line
- ▶ ⌨ **Hold:** Show more character variants
- ▶ 👁 Show password
- ▶ OK Confirm the entered characters

Numeric keypad

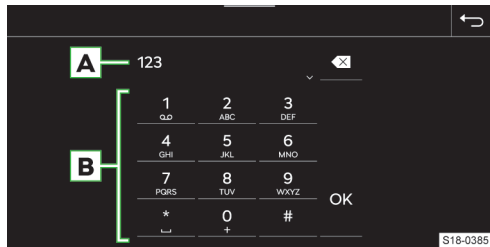

Keypad example

- A** Input line
 - ▶ ✖ Delete characters before the cursor
 - ▶ **Tap:** delete the last character
 - ▶ **Hold:** delete all characters
 - B** Keypad functional surfaces
 - ▶ OK Confirm the entered characters
- I** If it is possible depending on the context, alphanumeric characters can be entered by holding a function area with the number.

Operation

The Infotainment keypad is used to enter characters, letters and numbers.

The keypad will be **automatically displayed** when Infotainment prompts for characters.

Find

When entering characters, corresponding entries are searched for.

The entry to be searched for can be entered including diacritics.

The keyboard will only provide characters that match the stored entries.

- ▶ To display searched entries tap ∨.

Show additional keypad languages

To use the additional keypad languages, the desired languages must be set first.

- › Tap  or repeatedly tap the flag symbol until the desired language keypad is displayed.

Further character variants

- › Press and hold the sign with the symbol .
- › Select the desired symbol.

Setting up additional keyboard languages

- › Tap MENU >  > Additional keypad languages.

Voice control

Functionality

Voice control principle

Voice control works according to the principle of dialogue between the user and the Infotainment system.

The user says a voice command. The Infotainment system responds or executes the voice command.

Advanced voice control

The vehicle's advanced voice control enables the vehicle functions to be searched and operated online.

Advanced voice control understands fluent whole sentences. You do not need to use set commands or phrases.

The advanced voice control can, for example, search for special destinations or dictate SMS messages if the connected telephone makes this possible.

This function allows you to combine the search in the online and offline data of the Infotainment. The transition between online and offline search is seamless and imperceptible to the user.

Operating conditions

- ✓ Ignition on
- ✓ Infotainment switched on

Operating conditions for advanced voice control

To use the advanced voice control, the following conditions must also be met:

- ✓ The vehicle supports the function.
- ✓ The vehicle has Infotainment and functions that can be controlled by the advanced voice control.
- ✓ The ŠKODA Connect services are active.
- ✓ The vehicle is within range of a contractual mobile network, through which the connection to ŠKODA Connect Services is ensured.
- ✓ The level of protection of personal data is set to  Share my position .

Requirement for recognition of the activation command

- ✓ Activated menu item MENU >  > Voice control > Active

Operation

Switch on voice control

- › Press the  button on the multifunction steering wheel.

Or:

- › Say the activation command "OK Laura".

After switching on, the icon  is displayed in the status bar.

Enter voice command

- › Speak a voice command with voice control switched on.

During recognition of the voice command, the  icon is displayed.

The Infotainment system then executes the voice command or plays the message. During the message, the  icon is displayed.

After the execution of the voice command, voice control is switched off.

Correcting a voice command

- › During voice command input, press the  button on the multifunction steering wheel and say a new voice command.

Stopping voice control

Stopping leaves more time for voice command input, e.g. for searching for a phone contact.

- › Move your finger up or down over the Infotainment screen.

Or:

- › Say the voice command "pause".

Resuming stopped voice control

- › Press the  button on the multifunction steering wheel.

Or:

- › Tap on  in the Infotainment screen.

Stopping the played back message

- › Press the  button on the multifunction steering wheel.

Ending voice control

- › Press the  button on the multifunction steering wheel twice.

Or:

- › Say the voice command "cancel" during voice command input.

Restriction

For some Infotainment languages, there is no voice control available. The Infotainment system will indicate this.

The messages are generated by Infotainment. Flawless clarity (e.g. road or city name) cannot always be guaranteed.

You cannot use voice control while a phone call is in progress.

Settings

The following voice control functions are set in the menu **MENU** ›  › *Voice control*:

- ▶ Confirmation tones
- ▶ Enable/disable use of the activation word.

Self help

Starting acoustic help

- ▶ If the Infotainment system is expecting a voice command, say "Help".

The "Help" voice command can be issued repeatedly for further tips on voice control.

Displaying the help

- ▶ Tap on **MENU** ›  › .

Or:

- ▶ If Infotainment is expecting a voice command, say "Overview".

Switch example voice commands display on / off

The system offers the option of displaying example voice commands after switching on the voice control in the Infotainment screen.

- ▶ To **turn** **MENU** ›  › *voice control on/off*, tap › *Show in Infotainment system*.

Control Centre

Overview

Display of the control centre

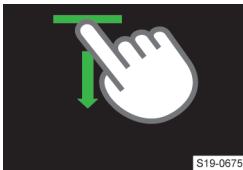

S19-0675

- ▶ Press the bar at the top of the screen and drag down.

Closing the control centre

- ▶ Tap on .

Or:

- ▶ Wait 5 seconds.

Control Centre

The Infotainment control centre can be used for quick access to the following functions:

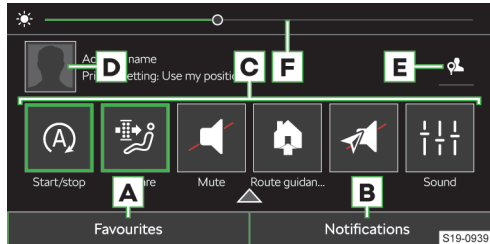

- A** Display and administration of functional surfaces of preferred features
- B** Display list of informational messages
- C** Preferred functions
- D** Display user account management
- E** Setting the personal data protection level
- F** Setting the instrument and key illumination

Set functional areas of preferred features

- ▶ To **display** editing mode hold any function surface of the preferred feature.
- ▶ To **add** the preferred feature, move the desired feature from the top of the screen to the functional surface at the bottom of the screen.
- ▶ To **close** edit mode, tap on .

Radio

Overview



Display menu

- ▶ Tap **RADIO**.

Or:

- ▶ Tap **MENU** › .

Analogue and digital radio player

- ▶ **A** Tap and select the desired frequency range.
- ▶ Tap  and search for or select the desired station.
- ▶ Tap on .

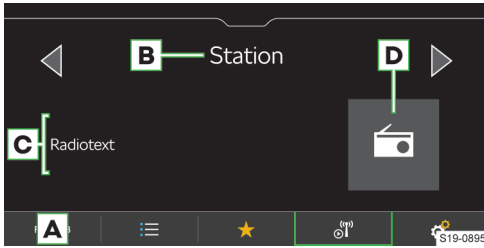

- A** Select source
- B** Station name
- C** Information about the broadcast content
- D** Station logos
- ☰ List of available stations
- ★ Show favourites
- ℹ Information about the station
- 🔍 Search stations manually (valid for AM and FM)
- ⚙ Settings

List of available analogue and digital radio stations

- Tap on ☰.
- ⦿ Played station
- ★ Station stored on the presets
- TP A traffic radio station is set
- 📺 The DAB transmitter emits images which are displayed in the information to the station
- 🔄 Manual update of the station list

In the station list, information about the programme type and the channel identification of the regional channel can be displayed.

Web radio player

- **A** tap and select a web radio station.
- Tap 🔍 and search or select web radio.
- Tap on ℹ.

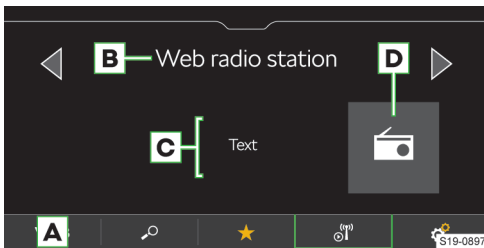

- A** Select source
- B** Station name
- C** Information about the broadcast content
- D** Station logos
- 🔍 List of web radio and podcasts

- ★ Show favourites
- ℹ Information about the programme as well as the broadcast content of the web radio
- ⚙ Settings

Podcast player

- Tap **A** and select an online radio station.
- Tap 🔍 and search for or select the desired podcast.
- Tap ℹ.



- A** Select source
- B** Podcast name
- C** Information about the broadcast content
- D** Podcast logo with the ℹ symbol

- ▶ **Tap:** Start playback
- ⏸ **Tap:** Pause
- ⏮ **Tap:** Go back 15 secs
- ⏭ **Tap:** Go forward 15 secs
- 📺 View episodes of the podcast being played
- 🔍 List of web radio stations and podcasts
- ★ Show favourites
- ℹ Show information about the podcast
- ⚙ Settings

List of web radio stations and podcasts

- Tap on 🔍.



- 🔍 Search for web radio stations and podcasts
- 📺 Recently played web radio stations and podcasts
- 📊 100 most popular web radio stations depending on the Infotainment language that has been set
- 📺 Go to podcasts and select

- 🔍 Search for and select web radio stations and podcasts based on the selected country
- 🌐 Search for and select web radio stations and podcasts based on the selected language
- ✔ Search for and select web radio stations and podcasts based on the selected genre
- 📁 See list of related podcasts based on content listened to
- 📁 See list of related podcasts based on content listened to

ℹ The podcasts are shown in the displayed lists with the icon 📁.

List of favourite stations and podcasts

› In the menu Radio, tap on ★.

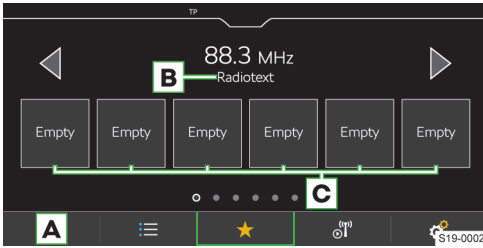

- A** Select source
- B** Radio text
- C** Station buttons for favourite stations and podcasts

Operation

Select station

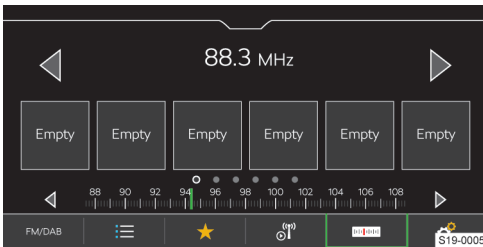

› Tap ◀ or ▶ at the top of the screen.

SCAN function

The function plays receivable stations of the selected frequency range in succession for a few seconds each.

- › To start automatic play 🔄, tap Scan.
- › To stop automatic play, tap **SCAN**.

Find stations manually

Manual search is available for AM and FM stations.

- › To display the 📁 functional surface for the FM station, turn on menu item 🔄 > Advanced settings > Station display: > FM switch on
- › In the Radio main menu, tap 📁.
- › To search in sequence, tap ◀ or ▶ next to the displayed frequency range scale.

Or:

- › Hold down the scroll mark on the frequency range scale and move it to the desired value.

Limitation

- › Infotainment supports digital radio reception in DAB and DAB+ formats.
- › Car parks, tunnels, tall buildings or mountains can restrict radio reception.
- › In the rear side windows, there are antennas for receiving the radio signal.
Covering the panes with foils or metal-coated labels may affect the reception of the radio signal.
- › The ŠKODA AUTO company assumes no responsibility for the availability, correct functioning and broadcast information of the RDS service.

Settings

Save the station currently being listened to as a favourite from the Radio main menu

- › Hold the desired station key for preferred stations until the station is stored.

Save station to favourites from the list of available stations

Applies to AM, FM and DAB frequency ranges.

- › Hold the line with the name of the desired station.
- › Tap the desired preset button.

Save channels from the list of web radio stations and podcasts

Valid for web radio stations and podcasts

- › Select a web radio station as the playback source.
- › Tap on 📁.
- › Go to the desired web radio station or podcast and select it.
- › Hold the line with the name of the desired station or podcast.
- › Tap the desired preset button.

ℹ With podcasts, it is not possible to save the individual episodes.

Deleting favourites

- › In the menu **Radio** 🔄 > Delete memory entries .

- ▶ To delete a station button for preferred stations, tap the desired station button and confirm the deletion.
- ▶ To delete all station buttons for preferred stations *Clear all* and confirm the deletion.

Functional surfaces ◀ ▶ for analogue and digital radios

Applies to AM, FM and DAB frequency ranges.

The variant for **changing stations** using the function surface ◀ ▶ in the **Radio** menu is set as follows:

- ▶ In the menu **Radio** ⚙ > *Arrow buttons* .
- ▶ Select the variant for switching between the stations stored on the station buttons or the stations stored in the list of available stations.

Functional areas ◀ ▶ for web radio stations and podcasts

Applies to web radio stations and podcasts.

The variant for **changing stations** using the function surface ◀ ▶ in the **Radio** menu is set as follows:

- ▶ In the menu **Radio** ⚙ > *Arrow buttons* .
- ▶ Select the variant for switching between the stations stored on the station keys or the last web stations and podcasts listened to.

Switch traffic reception (TP) for stations on/off

Applies to FM and DAB frequency range.

- ▶ In the menu **Radio** ⚙ > *Traffic program (TP)* .

Assign station logo from the Infotainment memory

Applies to the FM and DAB frequency ranges.

Infotainment offers the option of assigning logos, which are stored in the Infotainment memory, to the stations.

- ▶ In the menu **Radio** ⚙ > *Station logos* .
- ▶ Select the desired station and logo.

Switching off the station logo display

Applies to the FM and DAB frequency ranges.

- ▶ In the menu **Radio** ⚙ > *Station logos* .
- ▶ To select the desired station. *No station logo* .

Activating / deactivating automatic station logo assignment

Applies to the FM and DAB frequency ranges.

When the function is switched on, a station logo from the Infotainment memory is assigned when the station is stored on a preset.

- ▶ In the menu **Radio** ⚙ > *Advanced settings > Tap Automatic selection of station logos* .

Turn on/off radio text reception

Applies to the FM and DAB frequency ranges.

When the function is switched on and the station buttons are displayed, you can see more information

about the content broadcast from the station to which you are listening.

- ▶ In the menu **Radio** ⚙ > *Radio text* .

Regional FM station logo

Applies to the FM frequency range.

Infotainment provides the option of using country-specific FM station logos.

- ▶ In the menu **Radio** ⚙ > *Advanced settings > Region for station logo* .
- ▶ Choose country.

Switching additional announcements of the DAB transmitter on / off

Applies to the DAB frequency range.

When the function is switched on, other announcements are received as traffic announcements. These include e.g. weather news, sports reports, financial news etc.

- ▶ In the menu **Radio** ⚙ > *Advanced settings > Tap Additional DAB announcements* .

Switch RDS on/off

Applies to the FM frequency range.

The menu item is only available for some countries.

- ▶ In the menu **Radio** ⚙ > *Advanced settings > Radio Radio Data System (RDS)* .

If the **RDS function is disabled**, the following menu items in **FM station** settings are not available:

- ▶ Traffic program (TP)
- ▶ Radio text
- ▶ RDS Regional
- ▶ Automatic frequency change (AF)
- ▶ Regional station logo.

Switch automatic switching to a similar DAB transmitter on / off

Applies to the DAB frequency range.

When the function is switched on and there is signal loss from the DAB station being listened to, Infotainment automatically sets another DAB station with similar content.

- ▶ In the menu **Radio** ⚙ > *Advanced settings > Tap Switch to a similar station if weak reception* .

Displaying FM / DAB stations or FM stations in the list of available stations

Applies to the FM and DAB frequency ranges.

Depending on the following setting, the stations of the selected frequency range are displayed in the list of available stations.

- ▶ In the menu **Radio** ⚙ > *Advanced settings > Station display* .
- ▶ Select one of the following menu items:
 - ▶ *FM/DAB* - the list shows available FM and DAB stations.

- ▶ FM - the list shows available FM stations.

Sound quality of web radio stations and podcasts
Applies to web radio stations and podcasts.

- › To adjust the sound quality, in the **Radio** menu tap on › Audio quality: .
- › Choose low or high quality.

The quality you set affects the amount of data used in the data connection.

Quality also depends on the speed and availability of the data connection.

If playback failure occur, reduce the sound quality.

Media

What you should be mindful of

- ▶ Do not save any important data or that which has not been backed up on the connected audio sources. ŠKODA assumes no responsibility for lost or damaged files or connected audio sources.
- ▶ When changing or connecting an audio source, this may cause sudden changes in volume. Reduce the volume before changing or connecting an audio source.
- ▶ When connecting an audio source, the source information messages can be displayed. These messages must be observed and, if necessary, confirmed.
- ▶ The national copyright laws that apply in your country must be observed.

Overview

Display menu

- › Tap **MEDIA**.

Or:

- › Tap **MENU** › .

Music player

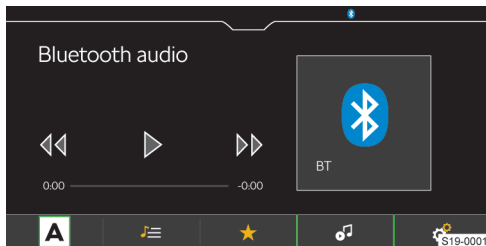

Choose source

Manage files / multimedia database

★ Show favourites

Details about the track being played

Settings

Video player

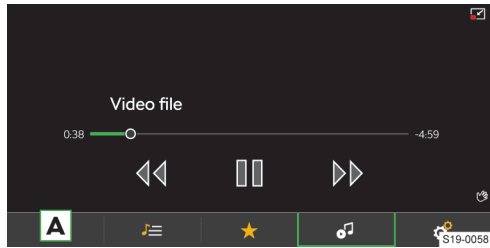

Select source

Manage files / multimedia database

★ Show favourites

Show video

Shrink image display

Enlarge the image display

Settings

Player controls

Operation - Basics

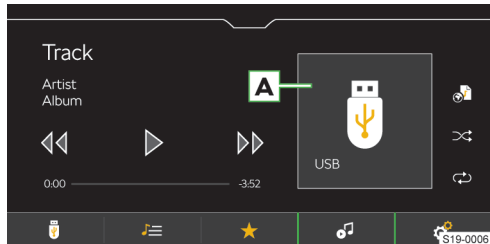

Album image / symbol of the connected source

- ▶ **Tap:** list available albums

▶ **Tap:** Start playback

▢▢ **Tap:** Pause

◀◀ **Within 3 seconds of starting playback, tap:** play the previous song

◀◀ **After 3 seconds from the start of playback, tap:** to play the current title from the beginning

◀◀ **Hold:** fast rewind within the track

▶▶ **Tap:** play the next track

▶▶ **Hold:** fast forward within the track

Movement within the title is also possible by dragging the finger over the timeline.

Advanced operation

- ▶ Turn on / off repeat playback of the current track
- ▶ Turn on / off repeat playback of the current album / folder
- ▶ Turn on / off random playback of the current album / folder
- ▶ Save the played track in the "My playlist" playlist

"My playlist" management

- ▶ To **display the playlist**, tap \mathbb{E} > \mathbb{E} > \mathbb{E} > \mathbb{E} .
- ▶ To **manage the playlist** tap \mathbb{E} in the displayed playlist.

The following activities can be carried out in playlist management:

- ▶ Control playback.
- ▶ Change the order of a title in the list by holding and moving \mathbb{E} to the desired position.
- ▶ Delete title.

Restriction

The availability of some media operation functions is dependent on the connected source and the software being used, e.g. Bluetooth®.

Settings

Manage favourites

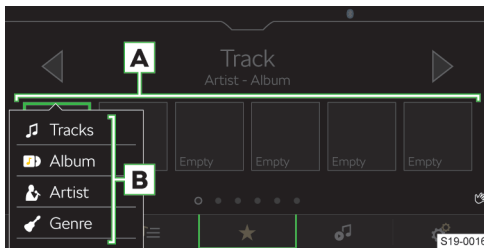

- ▶ To **save**, hold the desired functional area for favourites **A**.
- ▶ Choose one of the available list entries **B**.
- ▶ To **Clear**, in the menu **media** \mathbb{E} > tap on *Manage favourites*.
- ▶ To delete **a favourite**, tap on the list entry and confirm the deletion.

Or:

- ▶ To delete **all favourites** tap on *Clear all* and confirm the deletion.

Traffic

- ▶ To **turn on/off** traffic monitoring during playback of media files, go to the **Media** in the main menu \mathbb{E} > and tap on *Traffic program (TP)*.

Supported sources and files

Supported sources

Source	Interface	Type	Specification	File system
USB	USB 1.x; 2.x 3.x or higher with USB 2.x support	MSC	USB stick	VFAT FAT16 FAT32 exFAT NTFS
			HDD (without special software)	
			USB devices that use the USB mass storage support protocol	
		MTP	Devices running the Android or Windows Phone operating system that support the Media Transfer Protocol	
Apple	Devices with the iOS operating system and the iAP2 protocol	HFS+		
Bluetooth® player	Bluetooth®	-	Bluetooth® protocols A2DP and AVRCP (1.0 - 1.6)	-

Compatibility of mobile devices

It is possible to check the ŠKODAweb pages to see if Infotainment is compatible with the selected mobile device being tested. This check is carried out by using the following reference or by reading the QR code:

<http://go.skoda.eu/compatibility>



All information given is incidental and serves as information.

The ŠKODA AUTO company cannot guarantee full functionality and compatibility, e.g. due to a software update of the Infotainment and the mobile devices.

Supported audio files

Compression format	Codec type	File extension	Max. bit rate [kbps]	Max. sampling rate [kHz]	Multi channels
MPEG	MPEG 1 Layer 2	mp2	32 - 384	32, 44, 48	Mono, stereo, Joint stereo
	MPEG 2 Layer 2		8 - 160	16, 22, 24	
	MPEG 1 Layer 3	mp3	32 - 320	32, 44, 48	Mono, dual mono, Stereo, Joint Stereo
	MPEG 2 Layer 3		8 - 160	16, 22, 24	
	MPEG 2.5 Layer 3			8, 11, 12	

Compression format	Codec type	File extension	Max. bit rate [kbps]	Max. sampling rate [kHz]	Multi channels
WMA	Windows Media Audio 7	wma	6 - 192	8, 16, 22, 32, 44, 48, 96	Mono, stereo, Joint stereo
	Windows Media Audio 8		8 - 384		
	Windows Media Audio 9 and 9.1		8 - 768	8, 11, 16, 22, 32, 44, 48, 96	
	Windows Media Audio 9.2		8 - 320		
	Windows Media Audio 10		32 - 768	32, 44, 48, 96	
ADTS	AAC LC	aac	16 - 2048	22, 24, 32, 44, 48	Stereo
	AAC HE			16, 22, 24, 32, 44, 48	
	AAC HEv2				
MP4	M4A LC	m4a	16 - 400	22, 24, 32, 44, 48	Stereo
	M4A HE			16, 22, 24, 32, 44, 48	
	M4A HEv2		16 - 64		
OGG	OGG-Vorbis	ogg	8 - 576	8, 11, 12, 16, 22, 24, 32, 44, 48, 96	Mono, Stereo
FLAC	FLAC	flac	-	8, 11, 12, 16, 22, 24, 32, 44, 48, 64, 88, 96, 192	Mono, stereo, Joint stereo
RIFF	WAV	wav	64 - 3072	8, 11, 12, 16, 22, 24, 32, 44, 48, 96	Mono, Stereo
Monkey's	Monkey's	ape	8 - 192		
SBC	Bluetooth A2DP	-	8 - 345	8, 11, 12, 16, 22, 24, 32, 44, 48	Mono, stereo, Joint stereo
OPUS	OPUS	opus	6 - 2000	8 - 48	Mono, stereo, Multichannel

Files that are protected by **DRM-** and **iTunes®** methods are not supported by Infotainment.

Supported video files

Codec type	File extension	Max. recordings per second bit rate [Mbit/s]
MPEG 1	mpg mpeg m1v mPV	1.5
MPEG 2	mpg mpeg ps m2v	15
MPEG 4 (H.264)	m4p mp4 m4v mp4v mov	50
MPJEG		
MPEG 4 (ISO)		
Xvid	Xvid	20

Codec type	File extension	Max. recordings per second bit rate [Mbit/s]
WMV9	wmv asf	50

Supported playlists

Codec type	File extension
M3U	m3u
M3U8	m3u8
PLS	pls
WPL	wpl
ASX	asx

Images

Overview

Display menu
 ▶ Tap MENU >

Image viewer

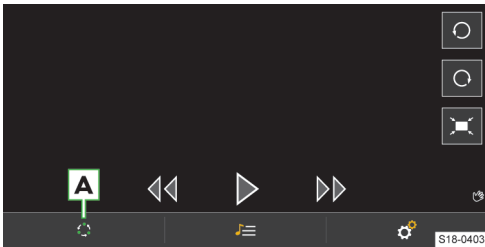

- A** Select source
- Manage files
- Settings

Operation

Operation using functional areas

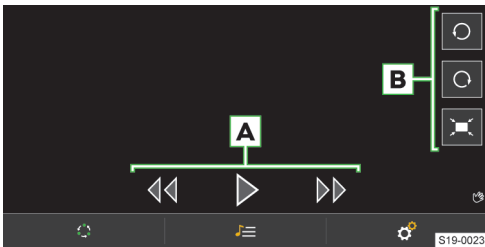

- A** View images
 - ▶ Show the next image
 - ▶ Show the previous image
 - ▶ Start slideshow

- ▶ Stop slideshow
- B** View image
 - ▶ Turn left
 - ▶ Turn right
 - ▶ Show in output size

Gesture control



▶ Display of the next image



▶ Display the previous image



▶ Increase the image size



▶ Reduce the image size



▶ Rotate by 90 °

Settings

The following Infotainment functions are set in the MENU > > menu:

- ▶ Display image size
- ▶ Display image duration during the slideshow
- ▶ Slideshow repeat

Supported sources and files

Supported sources

Source	Interface	Specifica- tion	File system
USB	USB 1.x; 2.x 3.x or higher with USB 2.x support	USB stick	VFAT
		HDD (without special software)	FAT16 FAT32 exFAT NTFS

Supported files

Codec type	File extension	Max. resolution [Mpx]
BMP	bmp	4
JPG; JPEG	jpg; jpeg	4 (Progressive Mode) 64
GIF	gif	4
PNG	png	4

The maximum supported image size is 20 MB.

Mobile device management

Cybernetic security

Your vehicle contains components that are used to exchange information and data between the vehicle and the connected mobile devices or the Internet.

These components have security mechanisms that minimise the risk of unauthorised access to the vehicle systems.

Regular software updates help reduce the risk of unauthorised access to vehicle systems and vehicle functions. The following guidelines must therefore be observed:

- ▶ Use only media carriers, Bluetooth® devices, and mobile devices that contain no harmful data or malware.
- ▶ Regularly update the software provided by ŠKODA AUTO.

We recommend having the system software and components updated by a specialist company.

⚠ WARNING

Risk of an accident!

Malware in the vehicle can influence and deactivate certain vehicle functions, or take over the controls of these where applicable.

- ▶ If the vehicle reacts in an unusual way, immediately reduce speed or stop the vehicle.
- ▶ Seek the help of a specialist garage.

⚠ WARNING

Malware in the vehicle may gain unauthorised access to the information and data of the vehicle, and on occasion, to connected mobile devices.

Overview

Using mobile device management, devices can be connected, disconnected, and interchanged.

Display mobile device management

- ▶ Tap on MENU > > Manage mobile devices.

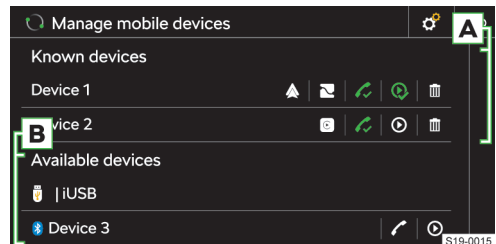

- ✓ The device enables a connection via the Bluetooth®“hands-free profile”
- ✓ The device is connected via the Bluetooth®“hands-free profile”
- ⊙ The device enables a connection via the Bluetooth® audio profile
- ⊙ The device is connected via the Bluetooth® audio profile
- ▣ Remove the device from the list **previously connected devices**
- ▲ The device enables a SmartLinkconnection to be made via Android Auto
- The device enables a SmartLinkconnection to be made via Apple CarPlay
- The device enables a SmartLinkconnection to be made via MirrorLink

A Connected / Previously connected devices

B Available devices

Limitations of mobile devices and applications

Availability of features

The availability of certain features depends on the type of mobile device, as well as that of the applications installed.

Compatibility of mobile devices

It is possible to check the ŠKODAweb pages to see if Infotainment is compatible with the selected mobile device being tested. This check is carried out by using the following reference or by reading the QR code:

<http://go.skoda.eu/compatibility>



All information given is incidental and serves as information.

The ŠKODA AUTO company cannot guarantee full functionality and compatibility, e.g. due to a software update of the Infotainment and the mobile devices.

Bluetooth® compatibility of mobile devices

Due to the large number of mobile devices, it is not possible to guarantee total Bluetooth® compatibility with Infotainment. Bluetooth® compatibility depends on the Bluetooth® version as well as the implementation of Bluetooth® protocols by the manufacturer of the mobile device.

Applications in mobile devices

Mobile devices can be used to install applications that allow you to view additional information on the Infotainment screen, or to operate the Infotainment system.

Due to the variety of applications, as well as their ongoing development, the available applications may not function on all mobile devices. ŠKODA AUTO assumes no liability for their proper functioning.

The scope of available applications and their functionality is dependent on the type of Infotainment, as well as the vehicle and country.

Information about ŠKODA applications

Detailed information about ŠKODA applications can be found on the website after reading the following QR code or link:

<http://go.skoda.eu/mobile-apps>



Connection set-up

Connect a mobile device to Infotainment

- › Find available Bluetooth® devices in the mobile device.
- › Select the Infotainment Bluetooth® unit.

The unit name can be determined by tapping **MENU** › › *Manage mobile devices* › › *device name*.

- › Confirm the PIN; enter it if necessary and then confirm.

Connect Infotainment to a non-paired mobile device

- › **MENU** › › *Manage mobile devices* .
- › Select the desired device from the list of **available devices**.
- › Select the desired Bluetooth® profile.
- › Confirm the PIN; enter it if necessary and then confirm.
- › If two devices are connected to the Infotainment, select the device to be replaced.

Connect Infotainment to a previously connected mobile device

- › **MENU** › › *Manage mobile devices* .

Or:

- › **PHONE** › › *Select mobile phone* .
- › Select the desired device from the list of **previously connected devices**.
- › Select the desired Bluetooth® profile.
- › If two devices are connected to the Infotainment, select the device to be replaced.

SmartLink connection

Infotainment provides the ability to connect SmartLink to compatible mobile devices using the following connection types:

- ▲ Android Auto
- Apple CarPlay
- MirrorLink

Mobile devices can be connected to the Infotainment via USB cable or Wi-Fi, as long as the mobile device supports it.

- › Connect the mobile device to the Infotainment via a USB cable or browse and connect to a wireless network.
- › Tap the icon of the supported connection.

Telephone

Overview

Display menu

- › Tap **PHONE**.

Or:

› Tap **MENU** › ↵.

i If the menu **phone** is not displayed, check whether the mobile device is connected.

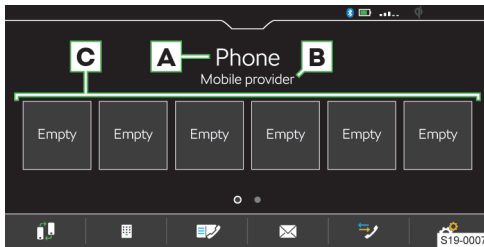

- A** Name of the connected telephone
 - ▶ **Tap:** Show list of previously connected phones
- B** Name of telephone service providers
 - ▶ If the symbol ▶ is displayed in front of the name, roaming is active.
- C** Preset buttons for preferred contacts
 - ▶ Change the main telephone with the additional telephone
 - ▶ Enter telephone number
 - ▶ Contact list
 - ▶ Text messages / emails
 - ▶ Call lists
 - ▶ Settings

Conditions for connecting a telephone with Infotainment

- ✓ The Bluetooth® function of the Infotainment and the telephone needs to be switched on.

The Bluetooth® function of the Infotainment is switched on in the menu item **MENU** › ⚙ › Manage mobile devices › ⚙ › Bluetooth.
- ✓ Visibility of the Infotainment is switched on.

The visibility of the Infotainment is switched on in the menu item **MENU** › ⚙ › Manage mobile devices › ⚙ › Visibility.
- ✓ The telephone is within signal range of the Infotainment's Bluetooth® unit.
- ✓ The telephone is compatible with Infotainment.

Telephone operation

Enter telephone number

- › In the **Phone** menu, tap on ☎.
 - › Enter the telephone number using the numeric keypad that is displayed.
- i** The displayed numeric keypad can also be used for searching for contacts.

If, for example, the digits 32 are entered, contacts with the letter sequence DA, FA, EB etc. are displayed next to the numeric keypad.

List of telephone contacts

The list of telephone contacts is imported from the connected main telephone.

- › To **display** the contact list in the **phone** menu, tap on ☎.
- › To **search** within the list, tap on Enter contact .
- › Enter the details you wish to find.
- › To **establish a connection** with a contact, tap the functional area showing the desired contact.

If a contact has multiple telephone numbers, select the telephone number from the displayed list.

- › To display the **details** for a contact, tap > .

Establish a connection to the voice mailbox number

- › In the **Phone** menu, tap on ☎ › 00.

Telephone conversation

Depending on the context of the telephone conversation, the following functions can be selected:

- ↶ End connection / reject incoming call / end call
- ✓ Answer an incoming call / return to the held call
- ⏸ Switch the ringer off / on
- 🔇 Hold a call
- 🔇/🔊 Switch the microphone off / on
- 👤 Show details of the caller
- ✉ Reject an incoming call using an SMS message
- 📞 Answer a call from the second telephone during a call on the first telephone

The ongoing call on the first telephone is terminated by accepting the call.

- › To **switch the call tone from the speakers to the telephone**, go to **telephone** in the menu and tap on ⚙ › speakerphone .
- › To **switch the call tone from the telephone to the speakers**, tap 📞.

Conference call

A conference call is a joint telephone conversation with a minimum of three and a maximum of six participants.

- › Make the next call during an ongoing conversation/conference.

Or:

- › Accept a new incoming call by tapping ✓ .
- › To **start** a conference call, tap 📞.

During an ongoing conference call, the following functions can be selected depending on the context:

- 🔇 Hold the conference call and leave temporarily (the conference will continue in the background)
- ✓ Return to the held conference call

- ⊗/⊕ Switch the microphone off / on
- End conference call
- 👤 Show details of the conference call

In the details of the conference call, depending on the connected telephone, the following functions can be selected:

- 👤 Show details of the conference call participants
- End conversation with the conference call participant
- 👤👤 Conversation with a participant outside of the conference call

Send a text message

- In the **Telephone** ☒ > ☒ menu, tap *Messages* > 📧 *New SMS*.
- Write a text message and confirm; a view of the message is displayed.
The message can be edited when the text area within the view is tapped.
- Search for or select the recipient of the message.
- Add more recipients or confirm selected recipients.
- Tap on *Send*.

Display received text messages

- In the **Telephone** ☒ > ☒ menu, tap *Messages* > ☒ or ☒.
- Messages that are received are displayed as individual messages or as messages in a conversation, depending on the following setting.
To **switch the display of messages in a conversation on or off**, tap in the **Phone** ☒ > menu *Show messages as conversation*.
- To **switch graphic notifications** regarding the receipt of a new message **on or off**, tap in the **Phone** ☒ > menu *New message notifications*.

☐ Infotainment offers the possibility to read the text message (context-dependent) by means of the generated Infotainment voice if 🗨 is tapped.

Send e-mails

- In the **Telephone** ☒ > ☒ menu, tap *Emails* > 📧 *New emails*.
- Write an e-mail and confirm that an e-mail is displayed.
The text can be edited when the text area within the view is tapped.
- Search for or select the recipient of the email.
- Add more recipients or confirm selected recipients.
- Enter the subject of the e-mail.
- Tap on *Send*.

Show received e-mails

- In the **Telephone** ☒ > ☒ menu, tap *Emails* > ☒.

- Select the desired e-mail.
- To **switch graphic notifications** regarding the receipt of a new email **on or off**, tap in the **Phone** ☒ > menu *New message notifications*.

Settings for Infotainment telephone functions

Telephone-Infotainment-Connection types

The way in which the telephone is connected depends on the number of phones currently connected to the Infotainment:

- ▶ **No telephone** - The telephone is connected as a main telephone.
- ▶ **One telephone** - The telephone is connected as an additional telephone.
- ▶ **Two telephones** - Select the telephone to be replaced.
- To **switch between the main telephone and the additional telephone**, tap on 🗨 in the **Phone** menu.

Connect the telephone to Infotainment

- Find available Bluetooth® devices on the phone.
- Select the Infotainment Bluetooth® unit.

The unit name can be determined by the menu item **MENU** > ☒ > *Manage mobile devices* > ☒ > *Device name*.

- Confirm the PIN; enter it if necessary and then confirm.

Connect Infotainment to a non-paired telephone - no telephone is connected

- Tap on **PHONE**.

Or:

- Tap on **MENU** > 🗨.
- Follow the instructions in the Infotainment screen.

Connecting Infotainment to a non-paired telephone - another telephone is connected

- Tap on **MENU** > ☒ > *Manage mobile devices*.
- Select the desired device from the list of **available devices**.
- Select the desired Bluetooth® profile.
- Confirm the PIN; enter it if necessary and then confirm.

The telephone is connected as an additional telephone.

Or:

- If two telephones are connected to the Infotainment, select the telephone to be replaced.

Connect Infotainment to a previously paired telephone

- **MENU** > ☒ > *Manage mobile devices*.

Or:

PHONE > > Select mobile phone .

- > Select the desired device from the list of **previously connected devices**.

The telephone is connected as an additional telephone.

Or:

- > If two telephones are connected to the Infotainment, select the telephone to be replaced.

Manage preset buttons for preferred contacts

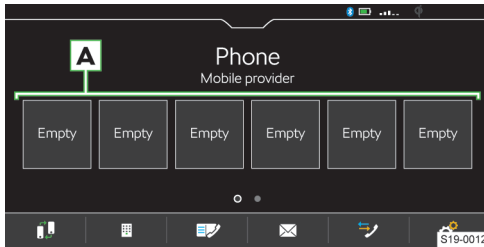

- > To **save** the desired preset button, hold **A**.
- > Select a contact from the displayed list.
- > If the contact contains multiple telephone numbers, choose the desired telephone number.
- > To **display the menu for deletion**, go to the **phone** menu > and tap on *Manage favourites* .
- > To delete **one** preset, tap on the list entry and confirm the deletion.

Or:

- > To delete **all** station buttons, tap *Clear all* and confirm the deletion.

Import telephone contacts

After first connecting the main telephone with Infotainment, telephone contacts will start to be imported into the Infotainment memory.

Infotainment can import up to 5000 telephone contacts together with contact pictures. Each contact can include max. 5 telephone numbers.

Depending on the type of telephone, import confirmation may be required.

Update telephone contacts

When re-connecting the telephone with Infotainment, an **automatic** update of the list is carried out.

- > For **manual** update of the list in the **phone** > menu tap on *Import contacts* .

Sort contacts in the phone book

- > In the **Telephone** > menu *Sort by*: Tap and select the sorting type.

Ringtone

Some phones do not allow the use of the telephone ringtone; instead, the Infotainment ringtone is used.

- > For **setting the Infotainment ringtone** in the **phone** > menu *select the ringtone* .
- > Select the ringtone.

Number for the voice mailbox

- > For **setting the voice mailbox number** in the **phone** > menu *Mailbox number*: .
- > Enter the voice mailbox number.

Turn the graphic notice regarding receiving a new message/email on or off

When the feature is on, the new message icon appears on the status bar and in the feature area for the messages when a new message/e-mail is received.

- > In the **Telephone** > menu *New message notifications* .

Simultaneous calls

This applies to some countries.

Depending on the connected telephone, it is possible to answer the next incoming call and hold the previous call.

- > To switch on simultaneous calls, tap on **telephone** > *Parallel talks*.

Wi-Fi

Functionality

The Wi-Fi can be used for the internet connection or for the SmartLinkConnection.

The Infotainment hotspot can connect up to 8 mobile devices. At the same time, the Infotainment can be connected to another hotspot.

- > To display the list of connected mobile devices, tap **MENU** > > *Wi-Fi* > *Infotainment system as hotspot* > *Connected devices*.

Overview of available hotspots

Display available hotspots

- > Tap **MENU** > > *Wi-Fi* > *Wi-Fi*.

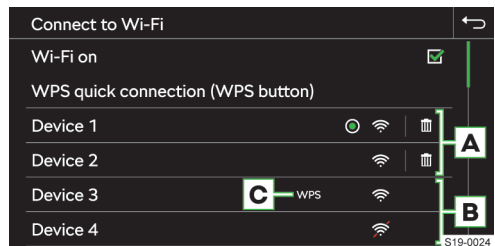

- A** Previously connected hotspots
- B** Available hotspots
- C** The hotspot supports the WPS connection

- ⊙ Currently connected hotspot
- ☰ Delete information about the hotspot connection
- 📶 Wi-Fi signal strength of the hotspot
- 📶 The Wi-Fi signal from the hotspot is not available

Function restriction

The Infotainment system can only be connected to a hotspot with WPA2 access protection.

Restriction of the Wi-Fi connection

In some countries, the Wi-Fi connection is restricted for legal reasons. When crossing the border of the country in question, the connection with a mobile device connected via Wi-Fi can be ended or restricted.

I Find out about country-specific legal restrictions. If necessary, switch off the Wi-Fi manually.

Settings

Connect a mobile device to the Infotainment hotspot

- Turn on the Infotainment's Wi-Fi hotspot in the menu item **MENU** › 📶 › Wi-Fi › Infotainment system as hotspot › Use as hotspot.
- Turn on the Wi-Fi on the mobile device.
- In the list of available Wi-Fi devices, look for Infotainment Wi-Fi.

The name of the Infotainment is taken from the menu item **MENU** › 📶 › Wi-Fi › Infotainment system as hotspot › Network name.

- Select the Infotainment hotspot and enter the required password.

The password for connecting to the Infotainment hotspot is taken from the menu item **MENU** › 📶 › Wi-Fi › Infotainment system as hotspot › Network key.

- Confirm the connection.

Connect Infotainment to the mobile device hotspot

- Turn on the Infotainment's Wi-Fi unit in the menu item **MENU** › 📶 › Wi-Fi › WLAN: › Wi-Fi active switch on
- Select the desired hotspot in the list of available hotspots.
- Enter the password for connecting to mobile devices.

I Infotainment stores passwords for previously connected hotspots.

Security level of the Infotainment hotspot

The security level is set at WPA2 and cannot be changed.

Activate/deactivate data transfer between the Infotainment and the connected device

- To turn data transmission on or off, tap **MENU** › 📶 › Wi-Fi › Infotainment system as hotspot › Connected devices › 📶.

Change the name of the Infotainment hotspot

- ▶ Tap **MENU** › 📶 › Wi-Fi › Infotainment system as hotspot › Network name.
- ▶ Enter the name and confirm.

Change password for connection to Infotainment hotspot

The password must be a minimum of 12 and a maximum of 63 characters.

- ▶ **MENU** › 📶 › Wi-Fi › Infotainment system as a hotspot › Network key .
- ▶ Enter and confirm the password.

Quick connection of Infotainment to the mobile device hotspot

- On the mobile device, turn on the hotspot, its visibility, and the option for WPS connection.
- **MENU** › 📶 › Wi-Fi › Wi-Fi: Tap › WPS quick connection (WPS button).

Automatic WPS connection

- Tap **MENU** › 📶 › Wi-Fi › Quick connection to Infotainment system.
- In the mobile device, switch on the option for connection via WPS.
- Wait for the connection to be established and, if necessary, confirm the respective messages.

Manual WPS connection

- In the mobile device, switch on the option for connection via WPS PIN.

The mobile device display will show the WPS PIN for connecting to the Infotainment.

- Tap **MENU** › 📶 › Wi-Fi › Quick connection to Infotainment system › **I** › WPS PIN.
- Enter the WPS PIN in the Infotainment and confirm.
- Wait for the connection to be established and, if necessary, confirm the respective messages.

Automatic connection using the QR code

- **MENU** › 📶 › Wi-Fi › Tap quick connection with infotainment system .
- In the mobile device, switch on the option for connection via QR Code.
- With the mobile device, read the QR code displayed on the Infotainment screen.
- Wait for the connection to be established and, if necessary, confirm the respective messages.

Tips for a perfect connection

- I**
 - ▶ Keep only the hotspot to be connected switched on and switch off the other hotspots.
 - ▶ Delete unused hotspots. This shortens the time required to establish a connection.
 - ▶ For some hotspots, the connection takes longer, so wait for the connection to finish.

- ▶ If the connection is interrupted, recheck the available hotspots and repeat the connection.

SmartLink

Functionality

SmartLink offers the ability to display and operate certified applications from a connected mobile device in the Infotainment screen.

Certification may be conditional upon the use of the latest update to the particular SmartLink application.

Applications include, for example, apps for route guidance, telephoning, listening to music, etc.

Mobile devices can be connected via a USB cable or WiFi.

Supported connection types

SmartLink supports the following connection types:

- ▶ Android Auto
- ▶ Apple CarPlay
- ▶ MirrorLink

Overview of the SmartLink connection

Menu SmartLink

› Tap **MENU** ›

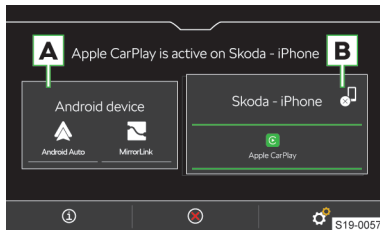

- A** Previously connected device
- B** Currently connection device
- ① Display information about SmartLink
- ⊗ Disconnection of the active connection
- 🎵 Disconnection of the active connection
- ⚙️ Settings in SmartLink menu

Android Auto

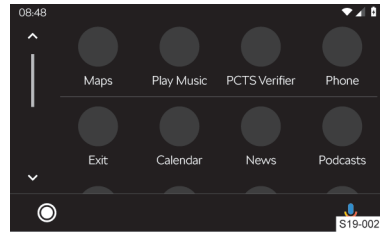

🕒 Overview of running applications, phone calls, incoming text messages, and more.

🗣️ Turn on voice control (Google Voice)

Apple CarPlay

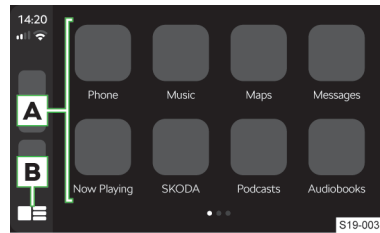

A List of available applications

B Depending on the duration of operation:

- ▶ **Tap:** Return to the menu Apple CarPlay
- ▶ **Hold:** Turn on voice control (Siri)

MirrorLink

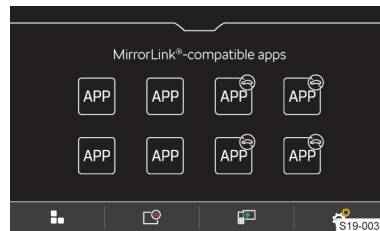

🕒 It is not possible to operate the application while driving

🏠 Return to the menu SmartLink

📱 List of running applications

🖼️ Display of the last running application in connected mobile devices

⚙️ Settings

Connection conditions

General connection conditions

- ✓ The mobile device supports the type of SmartLink connection Android Auto, Apple CarPlay or MirrorLink.
- ✓ Mobile devices, as well as the type of SmartLink connection, are supported in the respective market.
- ✓ Some connected mobile devices require the mobile device to be “unlocked”.

Conditions for Android Auto

- ✓ The device to be connected must have Android Auto connection.

A list of devices, supported regions and applications that support the Android Auto connection can be found on the Google, Inc. website.

- ✓ The Android Auto application needs to be installed on the mobile device.
- ✓ Some applications require the data connection in the mobile device to be turned on.
- ✓ Connect the mobile device for the first time when the vehicle is stationary.

Conditions for Apple CarPlay

- ✓ The device to be connected must have Apple CarPlay connection.

A list of devices, supported regions and applications that support the Apple CarPlay connection can be found on the Apple Inc website.

- ✓ Siri voice control is on.
- ✓ The data connection in the mobile device is switched on.

Conditions for MirrorLink

- ✓ The device to be connected must have MirrorLink connection.

A list of devices and applications that support the MirrorLink connection can be found on the websites of Car Connectivity Consortium®.

- ✓ The MirrorLink application needs to be installed on the mobile device.
- ✓ Some applications require the data connection in the connected mobile device to be turned on.

Operation

Operation of the running MirrorLink application

- Display of control surfaces at the bottom
- Display of control surfaces at the top
- ☰ Return to the menu MirrorLink

Restriction

Restriction of the Wi-Fi connection

In some countries, the Wi-Fi connection is restricted for legal reasons. When crossing the border of the country in question, the connection with a mobile device connected via Wi-Fi can be ended or restricted.

- ℹ Find out about country-specific legal restrictions. If necessary, switch off the Wi-Fi manually.

Restriction of SmartLink applications while driving

For reasons of safety, the operation of some SmartLink applications while driving is not possible or only limited.

Restriction of the navigation function

If route guidance is currently being carried out through Infotainment, this is ended when you start route guidance in the Apple CarPlay application.



If there is route guidance in the Apple CarPlay application, it is ended by starting the destination guidance using Infotainment.

SmartLink settings

Apple CarPlay - Connection via USB

- › Turn on the Infotainment.
- › Turn on the mobile device.
- › Connect the mobile device to the front USB input using a cable.
- › Choose to connect via Apple CarPlay.

Apple CarPlay - Connection via Wi-Fi from Infotainment

- › Turn on Bluetooth® and Bluetooth® visibility in the Apple mobile device.
- › Tap on **MENU** >  > *Manage mobile devices*.
- › In the displayed list, look for and select the desired device with the symbol .
- › Follow the instructions on the Infotainment screen and confirm the Bluetooth® pairing.
- › If another device is connected to the Infotainment, select the device to be replaced.

Apple CarPlay - Connect via Wi-Fi from mobile devices

To establish a connection, the following conditions must be met:

- ✓ The minimum iOS version is 9.
- ✓ No other mobile device can be connected via SmartLink.
- ✓ Wi-Fi and Bluetooth® functionality is switched on in the Infotainment system.
- › In the mobile device, turn on the CarPlay function.
- › Press and hold the  button on the multifunction steering wheel.

The Infotainment screen displays a connection message with the name of the Bluetooth® unit of the Infotainment.

- › Find available Bluetooth® devices on the phone.
- › Select the Infotainment Bluetooth® unit.
- › If necessary, confirm the PIN.
- › In the Infotainment screen, select the connection type Apple CarPlay.



Apple CarPlay - Disconnect

- › In the Apple CarPlay menu, tap on the function area “ŠKODA”.
- › Tap on .

Android Auto - Connection via USB

- › Turn on the Infotainment.
- › Turn on the mobile device.
- › Connect the mobile device to the front USB input using a cable.
- › Choose to connect via Android Auto.

Android Auto - Connection via Wi-Fi from Infotainment

- › Tap on MENU >  >  > mobile devices.
- › Select the desired device from the list of **available devices**.
- › Select the Bluetooth® hands-free profile.
- › Confirm the PIN; enter it if necessary and then confirm.
- › If another device is connected to the Infotainment, select the device to be replaced.
- › From the list of **known devices**, select the desired device with the ▲ symbol.



Android Auto - Connect via Wi-Fi from mobile devices

To establish a connection, the following conditions must be met:

- ✓ The minimum Android version is 5.
- ✓ No other mobile device can be connected via SmartLink.
- ✓ Wi-Fi and Bluetooth® functionality is switched on in the Infotainment system.

- › Find available Bluetooth® devices on the phone.
- › Select the Infotainment Bluetooth® unit.
- › If necessary, confirm the PIN.
- › In the Infotainment screen, select the connection type Android Auto.

Android Auto - Disconnect



- › In the Android Auto  > menu, tap “Return to SKODA”.
- › Tap on .

MirrorLink - Connection via USB

- › Turn on the Infotainment.
- › Turn on the mobile device.

- › Connect the mobile device to the front USB input using a cable.
- › Choose to connect through MirrorLink.

MirrorLink - Disconnect

- › In the MirrorLink menu, tap on .
- › Tap on .

Change to another device / connection type

Infotainment allows you to switch between currently connected devices and the connection type.

- › Tap on MENU > .
- › Select the desired device or connection type.

Navigation

Navigation announcements

Infotainment route guidance takes place using graphic driving recommendations and navigation announcements.

The navigation announcements are generated by the Infotainment system. Navigation announcement clarity (e.g. road or city name) cannot always be guaranteed.

Repeat the last navigation announcement

- › Tap on ... > .

Turn off navigation announcements

- › Tap on ... > .

Navigation overviews

Display menu

- › Tap MENU > .

Map overview



- A** Vehicle position
- B** Route
- C** Route view
-  End route guidance
- D** Display the destination input and route view menu
- E** Traffic obstruction

- F** Following driving recommendation
- G** POI
- H** Change map orientation
 - ▶ North-facing 2D map
 - ▶ 2D map facing the direction of travel
 - ▶ 3D map facing the direction of travel
- I** Road signs for the affected route section

- 📍 Find destination
- 📍 Centre the map on the vehicle position
- ⋮ **Display the settings menu**
- 🔊 Turn off navigation announcements
- 🔊 Repeat the last navigation announcement
- J** Display map in accordance with the following setting
 - ▶ Auto - Map in day / night mode depending on the vehicle lighting currently switched on
 - ▶ Day - Map in day mode
 - ▶ Night - Map in night mode
- K** Display navigation in the digital instrument cluster

L End route guidance

- 📍 Show the entire route
- ⚙️ Settings

Map display in the digital instrument cluster
 The map can be displayed in the digital instrument cluster or on the Infotainment display.

▶ To **change the display** tap ... > 📍 in the **Navigation** menu.

Find destination
 ▶ Tap ▶ > 📍.

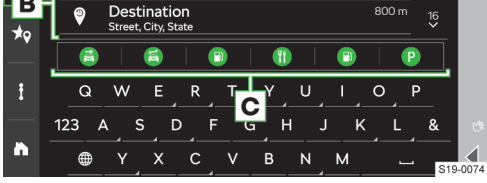

- A** Input line
- B** List of recently searched destinations
- C** POI categories
 - ▶ **Tap:** search for the selected category
- ☰ Show destination list
- 📍 Enter destination via address / find destination

Select the destination you are looking for
 ▶ Enter the details for the destination search.

▶ Select the desired destination.
 Destination details are displayed with the option of starting route guidance.

Selecting the destination entered via the address

▶ Tap on 📍.
 A menu for entering the destination via the address is displayed.
 ▶ Enter the required information.
 Destination details are displayed with the option of starting route guidance.

List of stored destinations

▶ Tap on ▶ > 📍.

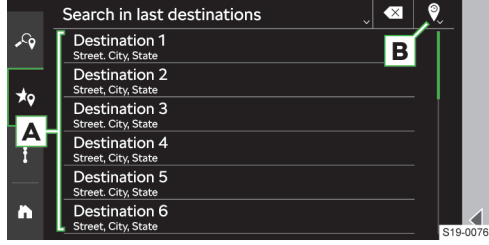

- A** List of stored destinations
- B** Select category of stored destinations
 - ▶ 📍 - Favourites
 - ▶ 📍 - Last destinations
 - ▶ 📍 - Telephone contact destinations

Selecting the stored destination

▶ Select the category of stored destinations.
 ▶ Select the desired destination.
 Destination details are displayed with the option of starting route guidance.

Recommended destinations

▶ Tap on ▶ > 📍.

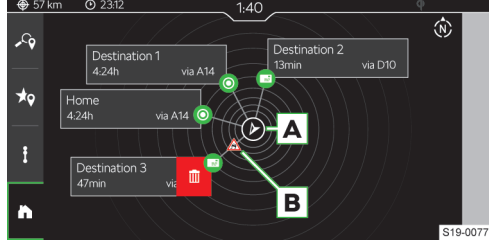

- A** North-facing vehicle position
- B** Traffic obstruction
- 🗑️ Delete the recommended destination

The view can display up to 5 recommended destinations in the following categories:

- ▶ Destination – home address
- ▶ Destination – business address
- ▶ Favourites
- ▶ Last destinations

Destination alignment depends on the direction in relation to the current vehicle position. The functional surface with the destination displays information about the estimated travel time to the destination.

If the vehicle has active online services and there is a traffic obstruction on the route to the destination, the traffic obstruction icon will be displayed.

Delete the recommended destination

- › Touch the functional surface for the recommended destination and swipe left.
- › Tap on .

Selecting destination by tapping the map point

- › Tap the desired item or the POI icon in the map.

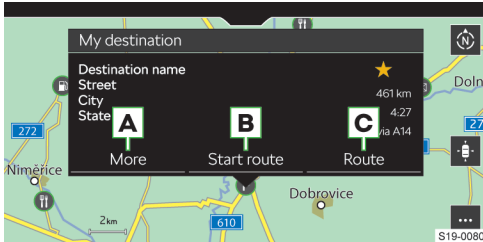



- A** Show destination details with the following possible settings:
 - ▶ ☆ - Save destination as a favourite
 - ▶ ☆ - Delete favourites
 - ▶  - Set destination as a starting point for route guidance in demo mode

- B** Start direct route guidance
- C** Route calculation

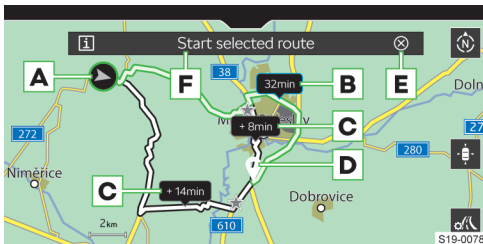
Route calculation



- A** Current vehicle position
- B** Proposed fastest route
- C** Alternative routes
- D** Destination position

- E** 15 s time countdown before automatic start of the route guidance
 - › **Tap:** Interrupt time countdown
- F** Start route guidance
 -  Show information on the selected route
 -  Set parameters for route calculation

Route overview

- › Tap on  > .

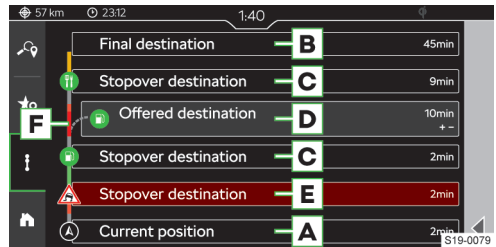

- A** Information on current vehicle position
- B** Final route destination
 - Tap:** the following menu items can be selected:
 - › Show on map
 - › Stop route guidance
- C** Route stopover
 - Tap:** the following menu items can be selected.
 - › Show on map
 - › Add stopover destination
- D** Destination provided by Infotainment on the route
 - Tap:** the following menu items can be selected.
 - › Show on map
 - › Delete
- E** Traffic obstruction on the route
 - Tap:** the following menu items can be selected.
 - › Show on map
 - › Avoid

- F** Route view

Changing route destinations

In the route overview, it is possible to exchange the destination and the intermediate destinations with each other and thus change their order.

- › Hold the line with the desired destination until the functional surface for the destination becomes free.
- › Move the destination to the desired position and release the functional surface.

The route is re-calculated.

Overview of traffic density

When ŠKODA online services are activated, traffic density information can be displayed in the form of the following colour scale in the route view **F**.

Low density — — — — — **High density**

– Traffic density information is not available

Touch operation**Gesture control**

▶ Move map

S19-0674

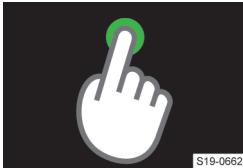

▶ Enter destination by tapping the map item

S19-0662

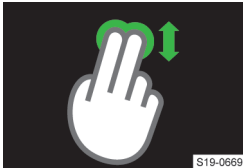

▶ Switch 2D/3D map display

S19-0669



▶ Zoom into the map

S19-0667



▶ Zoom out of the map

S19-0668



▶ Rotate the map

S19-0666

Limitation

Infotainment may give incorrect driving recommendations if the road conditions or the traffic do not match the navigation data. This can lead to the route guidance being carried out using a different route or proposing a change of direction in a one-way street.

Information for updating the navigation data must be requested from a ŠKODA partner.

Settings**Avoiding traffic obstructions**

If the function is switched on and the Infotainment receives information about a traffic obstruction on the route from online traffic information, the route is recalculated.

Infotainment may suggest a detour to avoid traffic obstructions, depending on the following settings:

- › ... > > Route guidance > Tap on Avoid traffic incidents .
- › Select the desired menu item.

Showing information on the destination / waypoint

The status line displays information on the distance and travel time to the destination, depending on the following setting.

- › ... > > Route guidance > Show information for: .
- › Select the desired menu item for the destination type.

Showing arrival time information in the destination / driving time

The status line displays information on the travel time depending on the following setting.

- › ... > > Route guidance > Time display: .
- › Select the desired menu item.

Switching display of country-specific speed limits on / off

When the function is switched on, the country-specific speed limits are displayed when crossing national borders.

- › Tap ... > > Route guidance > Country information at border crossings.

Switching the display of road signs on motorways and expressways on / off

When the function is switched on, Infotainment displays traffic and information signs on motorways and expressways.

- › Tap ... > > Route guidance > Information signs on motorways and dual carriageways.

Switching the fuel warning on / off

When the function is switched on and the fuel supply reaches the reserve area, a warning message appears with the option of going to the nearest petrol station.

- › Tap ... > ⚙ > Route guidance > Fuel warning.

Switching the speed limit warning on / off

- › Tap ... > ⚙ > Route guidance > Road signs.
- › Set the note type and the value for exceeding the permissible speed.

Settings for trailer operation

To calculate the correct route for trailer operation, switch on trailer inclusion.

- › Tap ... > ⚙ > Route guidance > Trailer > Include trailer.

Set the maximum speed for trailer operation to correctly calculate the route time.

- › Tap ... > ⚙ > Route guidance > Trailer > Maximum speed for trailers.
- › Set the maximum speed for the trailer.

Setting navigation announcements

- › Tap ... > ⚙ > navigation announcements.
- › Select and set the desired menu item.

Show preferred POI categories

Favourite POI categories are displayed on the map and provided in the destination search.

- › Tap ... > ⚙ > Basic functions > Define preferred POI categories.
- › Set favourite categories.

Setting home address

The defined destination of the home address is displayed in the overview of recommended destinations.

- › Tap ... > ⚙ > Basic functions > Enter home address.

Setting business address

The defined destination of the business address is displayed in the overview of recommended destinations.

- › Tap ... > ⚙ > Basic functions > Enter business address.

Switching demo mode on / off

In demo mode, the route guidance from the starting point of the demo mode to the selected destination is simulated.

When the function is switched on, Infotainment issues a query before the start of route guidance as to whether the route guidance should be carried out in the normal way or in demo mode.

- › ... > ⚙ > Tap on Basic functions > Demo mode .

Defining the starting point of the demo mode

- › Select or locate the desired destination to be the starting point of demo mode.
- › In the displayed destination details, tap More > .

Automatic update

Infotainment automatically carries out an update if the following conditions are met:

- ✓ The "Infotainment Online" online services are activated.
- ✓ An update of the navigation database for the current vehicle position or route destination is available.

Determining the navigation database version

- › Tap MENU > ⚙ > System information.

Updating the navigation database

Information for updating the navigation database must be requested from a ŠKODA partner.

Infotainment Columbus

Infotainment overview

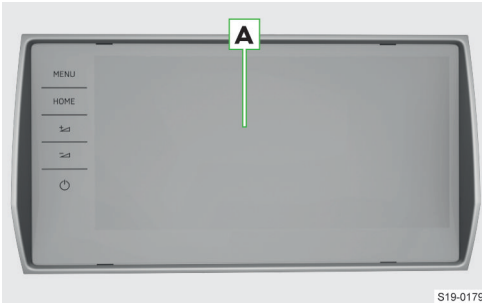

A Touchscreen

MENU All menus

HOME Favourite menus

⏮ Increase volume

⏭ Reduce volume

⏻ Depending on the status:

▶ **Infotainment switched off**

▶ **Tap:** Turn on Infotainment

▶ **Infotainment switched on**

▶ **Tap:** Switch sound off/on

▶ **Hold:** Switch off Infotainment

System

Limitation

For safety reasons, operation of some Infotainment functions while driving is not possible or is restricted.

The Infotainment system indicates this by means of a message in the screen.

Basic settings

Setting basic functions

The following Infotainment functions are set in the

MENU > ⚙ menu:

- ▶ Time and date
- ▶ Language
- ▶ Units
- ▶ Restore factory settings

Sound settings

The Infotainment sound is set in the menu **MENU** > ⏮.

The following menu items can be set:

- ▶ Setting the equalizer
- ▶ Adjusting the volume ratio

- ▶ Volume adjustment of individual Infotainment functions

The volume can be adjusted on e.g. one of the following menu items:

- ▶ Volume adjustment of voice commands
- ▶ Setting the maximum volume when Infotainment is turned on
- ▶ Speed-dependent volume setting
- ▶ Setting the Infotainment to mute with the parking aid switched on

Depending on the equipment, the following advanced sound settings can be set

- ▶ Setting space optimisation
- ▶ Setting the audio profiles according to genre
- ▶ Adjusting the subwoofer volume

Configuration wizard

The configuration wizard helps to set certain Infotainment functions.

The configuration assistant is automatically displayed if the ignition is switched on and if there are at least two menu items that have not been set up after switching on the Infotainment.

- ▶ To **switch off the automatic display**, when the configuration assistant is displayed tap *Don't show again*.
- ▶ For **manual display** tap **MENU** > ⚙ > *Configuration wizard*.

Set up menu HOME

- ▶ To **display another page** of the HOME menu, press the screen with two fingers and drag it to the left or right.

To **add the preferred menu**, proceed as follows:

- ▶ Tap on an empty functional surface.

Or:

- ▶ Press and hold an occupied functional surface and then tap on an empty functional area.
- ▶ Select a menu with the desired dimension of the functional surface.
- ▶ Tap on × to exit edit mode.

To **remove the preferred menu**, proceed as follows:

- ▶ Press an occupied functional surface.
- ▶ Tap on ⏻.
- ▶ Tap on × to exit edit mode.

Set up menu MENU

The position of the functional surfaces in the MENU menu can be customized as follows:

- ▶ Press and hold the desired functional surface until it is free.
- ▶ Move the functional surface to a different position.

Troubleshooting

Infotainment not responding

If the infotainment does not respond, restart it as follows:

- > Hold ϕ for longer than 10 s.
- > Wait for the restart to complete.

System update

We recommend having the system update carried out by a specialist company.

The system update ensures optimal function of the Infotainment system, e.g. compatibility with new phones.

Determine system version

- > Tap **MENU** >  > *System information*.

Screen

Overview

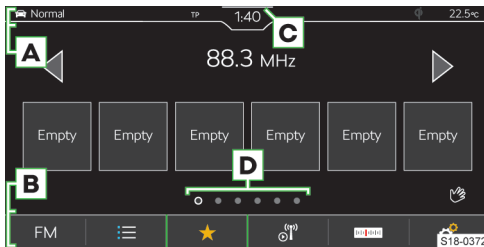

- A** Status bar
- B** Bar with the functional surfaces of the displayed menu
- C** Display of the control centre
- D** Other pages of the menu

Operation

① NOTICE

Danger of screen damage!

- > The Infotainment screen is operated by **touching it lightly with your finger**.

In principle, operation by touch is identical to the operation of a mobile phone.

The following operating modes are specific to the Infotainment system.

Dragging up or down with two fingers

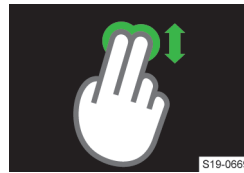

- > Quickly review the list of phone contacts
- > Switch 2D/3D map display

Dragging left or right with two fingers



- > Display next page of the HOME menu

Pulling apart with two fingers



- > Enlarge image
- > Zoom into the map

Pulling together with two fingers



- > Minimize image
- > Zoom out of the map

Turn two fingers



- > Rotate image
- > Rotate the map

Contactless gesture control

The Infotainment menus marked with the  symbol can be controlled by hand gestures.



- > Gesture control is achieved by slowly moving the hand back and forth approximately 8 cm above the lower edge of the screen.

Depending on the setting, a recognized gesture can be confirmed acoustically and animated.

Displaying operation help

- ▶ Tap on MENU > ⓘ > 🗨.

Settings

The following basic screen functions are set in the menu MENU > ⚙ > Screen:

- ▶ Brightness level of the screen
- ▶ Switch off the screen
- ▶ Display the time
- ▶ Confirmation sounds and animations

Keypad

Keypad overview

The arrangement of the keyboard characters depends on the set infotainment language.

Depending on the context, the following types are used in infotainment:

- ▶ Alphanumeric
- ▶ Numeric
- ▶ Keyboard for input
- ▶ Keyboard for search

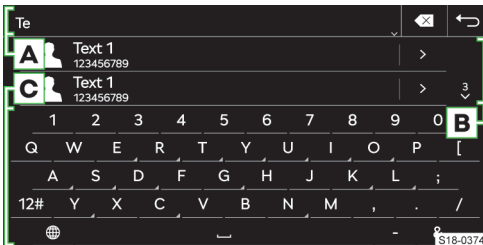

Keypad example

A Input line

- ▶ ✖ Delete characters before the cursor
 - ▶ **Tap:** delete the last character
 - ▶ **Hold:** delete all characters one after the other
- ▶ ∨ Display functional surfaces for moving the cursor in the input line
 - ▶ < Move cursor to the left
 - ▶ > Move cursor to the right

B Entries found

- ▶ ∨ Show list

C Keypad functional surfaces

- ▶ ↑ Change to lowercase
- ▶ ↲ Switch to first having an upper-case letter, followed by lower-case letters
- ▶ ↑ Switch to uppercase

- ▶ **ABC/ABB** Switch to the language keypad
- ▶ **12#** Switch to the numeric and character keypad
- ▶ **1/2/2/2** Switch to other character variants
- ▶ 🌐 Show additional keyboard languages
- ▶ ⏪ Insert spaces
- ▶ ↵ The next line
- ▶ 🗨 **Hold:** Show more character variants
- ▶ 👁 Show password
- ▶ OK Confirm the entered characters

Numeric keypad

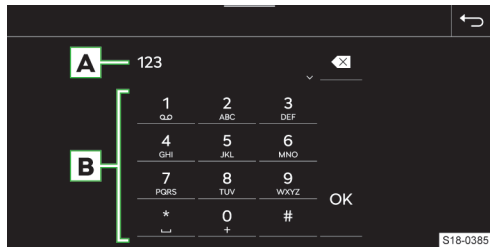

Keypad example

A Input line

- ▶ ✖ Delete characters before the cursor
 - ▶ **Tap:** delete the last character
 - ▶ **Hold:** delete all characters

B Keypad functional surfaces

- ▶ OK Confirm the entered characters

I If it is possible depending on the context, alphanumeric characters can be entered by holding a function area with the number.

Operation

The Infotainment keypad is used to enter characters, letters and numbers.

The keypad will be **automatically displayed** when Infotainment prompts for characters.

Find

When entering characters, corresponding entries are searched for.

The entry to be searched for can be entered including diacritics.

The keyboard will only provide characters that match the stored entries.

- ▶ To display searched entries tap ∨.

Show additional keypad languages

To use the additional keypad languages, the desired languages must be set first.

- › Tap  or repeatedly tap the flag symbol until the desired language keypad is displayed.

Further character variants

- › Press and hold the sign with the symbol .
- › Select the desired symbol.

Setting up additional keyboard languages

- › Tap MENU >  > Additional keypad languages.

Voice control

Functionality

Voice control principle

Voice control works according to the principle of dialogue between the user and the Infotainment system.

The user says a voice command. The Infotainment system responds or executes the voice command.

Advanced voice control

The vehicle's advanced voice control enables the vehicle functions to be searched and operated online.

Advanced voice control understands fluent whole sentences. You do not need to use set commands or phrases.

The advanced voice control can, for example, search for special destinations or dictate SMS messages if the connected telephone makes this possible.

This function allows you to combine the search in the online and offline data of the Infotainment. The transition between online and offline search is seamless and imperceptible to the user.

Operating conditions

- ✓ Ignition on
- ✓ Infotainment switched on

Operating conditions for advanced voice control

To use the advanced voice control, the following conditions must also be met:

- ✓ The vehicle supports the function.
- ✓ The vehicle has Infotainment and functions that can be controlled by the advanced voice control.
- ✓ The ŠKODA Connect services are active.
- ✓ The vehicle is within range of a contractual mobile network, through which the connection to ŠKODA Connect Services is ensured.
- ✓ The level of protection of personal data is set to  Share my position .

Requirement for recognition of the activation command

- ✓ Activated menu item MENU >  > Voice control > Active

Operation

Switch on voice control

- › Press the  button on the multifunction steering wheel.

Or:

- › Say the activation command "OK Laura".

After switching on, the icon  is displayed in the status bar.

Enter voice command

- › Speak a voice command with voice control switched on.

During recognition of the voice command, the  icon is displayed.

The Infotainment system then executes the voice command or plays the message. During the message, the  icon is displayed.

After the execution of the voice command, voice control is switched off.

Correcting a voice command

- › During voice command input, press the  button on the multifunction steering wheel and say a new voice command.

Stopping voice control

Stopping leaves more time for voice command input, e.g. for searching for a phone contact.

- › Move your finger up or down over the Infotainment screen.

Or:

- › Say the voice command "pause".

Resuming stopped voice control

- › Press the  button on the multifunction steering wheel.

Or:

- › Tap on  in the Infotainment screen.

Stopping the played back message

- › Press the  button on the multifunction steering wheel.

Ending voice control

- › Press the  button on the multifunction steering wheel twice.

Or:

- › Say the voice command "cancel" during voice command input.

Restriction

For some Infotainment languages, there is no voice control available. The Infotainment system will indicate this.

The messages are generated by Infotainment. Flawless clarity (e.g. road or city name) cannot always be guaranteed.

You cannot use voice control while a phone call is in progress.

Settings

The following voice control functions are set in the menu **MENU** >  > *Voice control*:

- > Confirmation tones
- > Enable/disable use of the activation word.

Self help

Starting acoustic help

- > If the Infotainment system is expecting a voice command, say "Help".

The "Help" voice command can be issued repeatedly for further tips on voice control.

Displaying the help

- > Tap on **MENU** >  > .

Or:

- > If Infotainment is expecting a voice command, say "Overview".

Switch example voice commands display on / off

The system offers the option of displaying example voice commands after switching on the voice control in the Infotainment screen.

- > To **turn** **MENU** >  > *voice control on/off*, tap > *Show in Infotainment system*.

Control centre

Overview

Display of the control centre

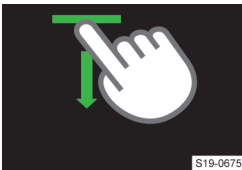

S19-0675

- > Press the bar at the top of the screen and drag down.

Closing the control centre

- > Tap on .

Or:

- > Wait 5 seconds.

Control Centre

The Infotainment control centre can be used for quick access to the following functions:

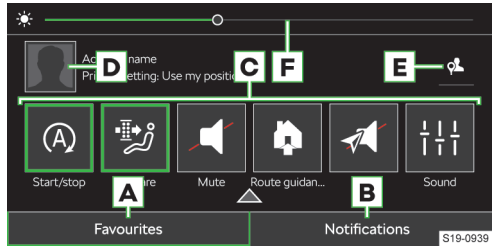

- A** Display and administration of functional surfaces of preferred features
- B** Display list of informational messages
- C** Preferred functions
- D** Display user account management
- E** Setting the personal data protection level
- F** Setting the instrument and key illumination

Set functional areas of preferred features

- > To **display** editing mode hold any function surface of the preferred feature.
- > To **add** the preferred feature, move the desired feature from the top of the screen to the functional surface at the bottom of the screen.
- > To **close** edit mode, tap on .



Radio

Overview

Display menu

- > Tap **MENU** > .

Analogue and digital radio player

- > **A** Tap and select the desired frequency range.
- > Tap  and search for or select the desired station.
- > Tap on .

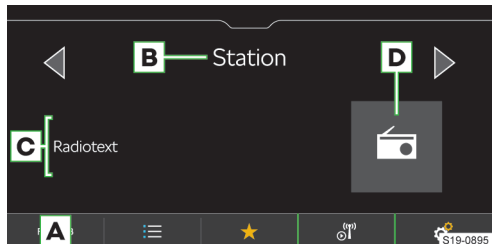

S19-0895

- A** Select source
- B** Station name
- C** Information about the broadcast content
- D** Station logos
- ☰ List of available stations
- ★ Show favourites
- 📡 Information about the station
- 🔍 Search stations manually (valid for AM and FM)
- ⚙️ Settings

List of available analogue and digital radio stations

▶ Tap on ☰.

- ⦿ Played station
- ★ Station stored on the presets
- TP A traffic radio station is set
- 📡 The DAB transmitter emits images which are displayed in the information to the station
- 🔄 Manual update of the station list

In the station list, information about the programme type and the channel identification of the regional channel can be displayed.

Web radio player

- ▶ **A** tap and select a web radio station.
- ▶ Tap 🔍 and search or select web radio.
- ▶ Tap on 📡.

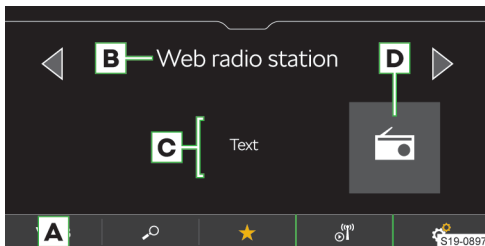

- A** Select source
- B** Station name
- C** Information about the broadcast content
- D** Station logos
- 🔍 List of web radio and podcasts
- ★ Show favourites
- 📡 Information about the programme as well as the broadcast content of the web radio
- ⚙️ Settings

Podcast player

- ▶ Tap **A** and select an online radio station.
- ▶ Tap 🔍 and search for or select the desired pocast.
- ▶ Tap 📡.



- A** Select source
- B** Podcast name
- C** Information about the broadcast content
- D** Podcast logo with the 📡 symbol

- ▶ **Tap:** Start playback
- ⏸ **Tap:** Pause
- ⏮ **Tap:** Go back 15 secs
- ⏭ **Tap:** Go forward 15 secs
- 📖 View episodes of the podcast being played
- 🔍 List of web radio stations and podcasts
- ★ Show favourites
- 📡 Show information about the podcast
- ⚙️ Settings

List of web radio stations and podcasts

▶ Tap on 🔍.



- 🔍 Search for web radio stations and podcasts
- 📖 Recently played web radio stations and podcasts
- 📊 100 most popular web radio stations depending on the Infotainment language that has been set
- 📍 Go to podcasts and select
- 🌐 Search for and select web radio stations and podcasts based on the selected country
- 🌐 Search for and select web radio stations and podcasts based on the selected language
- 👉 Search for and select web radio stations and podcasts based on the selected genre
- 📖 See list of related podcasts based on content listened to

See list of related podcasts based on content listened to

The podcasts are shown in the displayed lists with the icon.

List of favourite stations and podcasts

In the menu Radio, tap on ★.

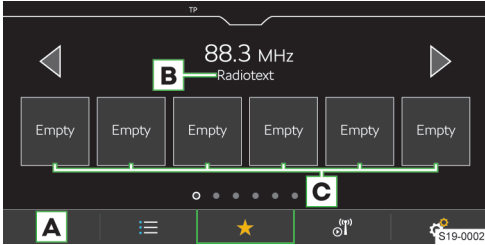

- A** Select source
- B** Radio text
- C** Station buttons for favourite stations and podcasts

Operation

Select station

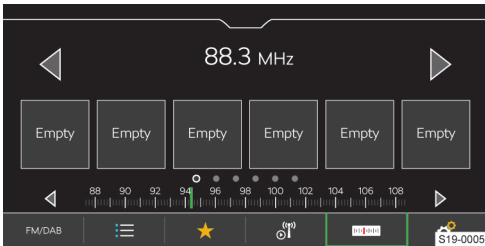

Tap < or > at the top of the screen.

SCAN function

The function plays receivable stations of the selected frequency range in succession for a few seconds each.

- To start automatic play, tap Scan.
- To stop automatic play, tap **SCAN**.

Find stations manually

Manual search is available for AM and FM stations.

- To display the functional surface for the FM station, turn on menu item > Advanced settings > Station display: > FM switch on
- In the Radio main menu, tap **FM**.
- To search in sequence, tap < or > next to the displayed frequency range scale.

Or:

Hold down the scroll mark on the frequency range scale and move it to the desired value.

Limitation

- Infotainment supports digital radio reception in DAB and DAB+ formats.
- Car parks, tunnels, tall buildings or mountains can restrict radio reception.
- In the rear side windows, there are antennas for receiving the radio signal.

Covering the panes with foils or metal-coated labels may affect the reception of the radio signal.

- The ŠKODA AUTO company assumes no responsibility for the availability, correct functioning and broadcast information of the RDS service.

Settings

Save the station currently being listened to as a favourite from the Radio main menu

Hold the desired station key for preferred stations until the station is stored.

Save station to favourites from the list of available stations

Applies to AM, FM and DAB frequency ranges.

- Hold the line with the name of the desired station.
- Tap the desired preset button.

Save channels from the list of web radio stations and podcasts

Valid for web radio stations and podcasts

- Select a web radio station as the playback source.
- Tap on **FM**.
- Go to the desired web radio station or podcast and select it.
- Hold the line with the name of the desired station or podcast.
- Tap the desired preset button.

With podcasts, it is not possible to save the individual episodes.

Deleting favourites

- In the menu **Radio** > Delete memory entries .
- To delete a station button for preferred stations, tap the desired station button and confirm the deletion.
- To delete all station buttons for preferred stations **Clear all** and confirm the deletion.

Functional surfaces < > for analogue and digital radios

Applies to AM, FM and DAB frequency ranges.

The variant for **changing stations** using the function surface ◀▶ in the **Radio** menu is set as follows:

- ▶ In the menu **Radio** ⚙️ > *Arrow buttons:* .
- ▶ Select the variant for switching between the stations stored on the station buttons or the stations stored in the list of available stations.

Functional areas ◀▶ for web radio stations and podcasts

Applies to web radio stations and podcasts.

The variant for **changing stations** using the function surface ◀▶ in the **Radio** menu is set as follows:

- ▶ In the menu **Radio** ⚙️ > *Arrow buttons:* .
- ▶ Select the variant for switching between the stations stored on the station keys or the last web stations and podcasts listened to.

Switch traffic reception (TP) for stations on/off

Applies to FM and DAB frequency range.

- ▶ In the menu **Radio** ⚙️ > *Traffic program (TP)* .

Assign station logo from the Infotainment memory

Applies to the FM and DAB frequency ranges.

Infotainment offers the option of assigning logos, which are stored in the Infotainment memory, to the stations.

- ▶ In the menu **Radio** ⚙️ > *Station logos* .
- ▶ Select the desired station and logo.

Switching off the station logo display

Applies to the FM and DAB frequency ranges.

- ▶ In the menu **Radio** ⚙️ > *Station logos* .
- ▶ To select the desired station. *No station logo* .

Activating / deactivating automatic station logo assignment

Applies to the FM and DAB frequency ranges.

When the function is switched on, a station logo from the Infotainment memory is assigned when the station is stored on a preset.

- ▶ In the menu **Radio** ⚙️ > *Advanced settings* > *Tap Automatic selection of station logos* .

Turn on/off radio text reception

Applies to the FM and DAB frequency ranges.

When the function is switched on and the station buttons are displayed, you can see more information about the content broadcast from the station to which you are listening.

- ▶ In the menu **Radio** ⚙️ > *Radio text* .

Regional FM station logo

Applies to the FM frequency range.

Infotainment provides the option of using country-specific FM station logos.

- ▶ In the menu **Radio** ⚙️ > *Advanced settings* > *Region for station logo:* .
- ▶ Choose country.

Switching additional announcements of the DAB transmitter on / off

Applies to the DAB frequency range.

When the function is switched on, other announcements are received as traffic announcements. These include e.g. weather news, sports reports, financial news etc.

- ▶ In the menu **Radio** ⚙️ > *Advanced settings* > *Tap Additional DAB announcements* .

Switch RDS on/off

Applies to the FM frequency range.

The menu item is only available for some countries.

- ▶ In the menu **Radio** ⚙️ > *Advanced settings* > *Radio Radio Data System (RDS)* .

If the **RDS function is disabled**, the following menu items in **FM station** settings are not available:

- ▶ Traffic program (TP)
- ▶ Radio text
- ▶ RDS Regional
- ▶ Automatic frequency change (AF)
- ▶ Regional station logo.

Switch automatic switching to a similar DAB transmitter on / off

Applies to the DAB frequency range.

When the function is switched on and there is signal loss from the DAB station being listened to, Infotainment automatically sets another DAB station with similar content.

- ▶ In the menu **Radio** ⚙️ > *Advanced settings* > *Tap Switch to a similar station if weak reception* .

Displaying FM / DAB stations or FM stations in the list of available stations

Applies to the FM and DAB frequency ranges.

Depending on the following setting, the stations of the selected frequency range are displayed in the list of available stations.

- ▶ In the menu **Radio** ⚙️ > *Advanced settings* > *Station display:* .
- ▶ Select one of the following menu items:

- ▶ *FM/DAB* - the list shows available FM and DAB stations.
- ▶ *FM* - the list shows available FM stations.

Sound quality of web radio stations and podcasts

Applies to web radio stations and podcasts.

- ▶ To adjust the sound quality, in the **Radio** menu tap on ⚙️ > *Audio quality:* .
- ▶ Choose low or high quality.

The quality you set affects the amount of data used in the data connection.

Quality also depends on the speed and availability of the data connection.

ⓘ If playback failure occur, reduce the sound quality.

Media

What you should be mindful of

- ▶ Do not save any important data or that which has not been backed up on the connected audio sources. ŠKODA assumes no responsibility for lost or damaged files or connected audio sources.
- ▶ When changing or connecting an audio source, this may cause sudden changes in volume. Reduce the volume before changing or connecting an audio source.
- ▶ When connecting an audio source, the source information messages can be displayed. These messages must be observed and, if necessary, confirmed.
- ▶ The national copyright laws that apply in your country must be observed.

Overview

Display menu

> Tap on MENU > 🎵.

Music player

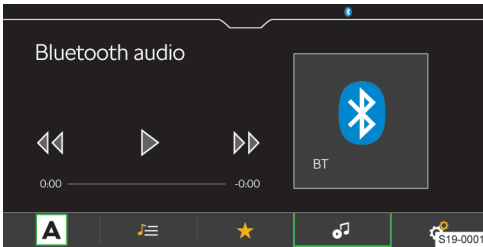

A Choose source

- 📁 Manage files / multimedia database
- ★ Show favourites
- 🎵 Details about the track being played
- ⚙️ Settings

Video player

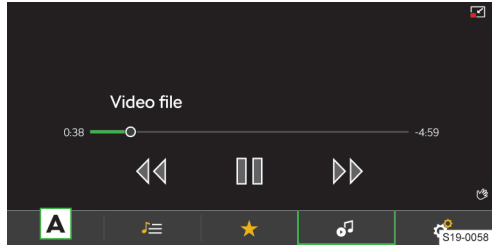

A Select source

- 📁 Manage files / multimedia database
- ★ Show favourites
- 🎵 Show video
- 📐 Shrink image display
- 📐 Enlarge the image display
- ⚙️ Settings

Player controls

Operation - Basics

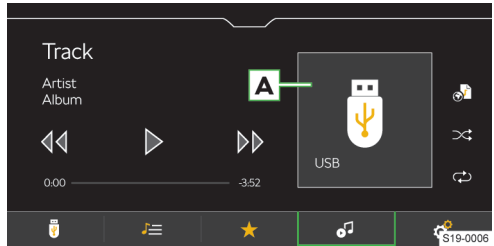

A Album image / symbol of the connected source

- ▶ **Tap:** list available albums
- ▶ **Tap:** Start playback
- ⏸ **Tap:** Pause
- ⏮ **Within 3 seconds of starting playback, tap:** play the previous song
- ⏮ **After 3 seconds from the start of playback, tap:** to play the current title from the beginning
- ⏮ **Hold:** fast rewind within the track
- ▶ **Tap:** play the next track
- ▶ **Hold:** fast forward within the track

Movement within the title is also possible by dragging the finger over the timeline.

Advanced operation

- 🔄 Turn on / off repeat playback of the current track
- 🔄 Turn on / off repeat playback of the current album / folder

- ⊗ Turn on / off random playback of the current album / folder
- 🎵 Save the played track in the "My playlist" playlist

"My playlist" management

- ▶ To display the playlist, tap  >  >  > .

- ▶ To manage the playlist tap  in the displayed playlist.

The following activities can be carried out in playlist management:

- ▶ Control playback.
- ▶ Change the order of a title in the list by holding and moving  to the desired position.
- ▶ Delete title.

Restriction

The availability of some media operation functions is dependent on the connected source and the software being used, e.g. Bluetooth®.

Settings

Manage favourites

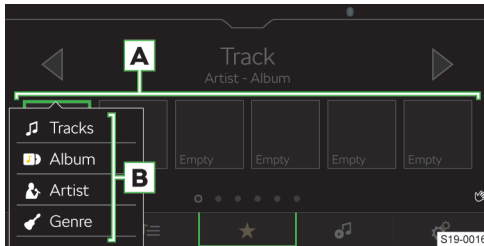

- ▶ To save, hold the desired functional area for favourites **A**.
- ▶ Choose one of the available list entries **B**.
- ▶ To Clear, in the menu **media**  > tap on *Manage favourites*.
- ▶ To delete a favourite, tap on the list entry and confirm the deletion.

Or:

- ▶ To delete all favourites tap on *Clear all* and confirm the deletion.

Traffic

- ▶ To turn on/off traffic monitoring during playback of media files, go to the **Media** in the main menu  > and tap on *Traffic program (TP)*.

Supported sources and files

Supported sources

Source	Interface	Type	Specification	File system
USB	USB 1.x; 2.x 3.x or higher with USB 2.x support	MSC	USB stick	VFAT FAT16 FAT32 exFAT NTFS
			HDD (without special software)	
			USB devices that use the USB mass storage support protocol	
		MTP	Devices running the Android or Windows Phone operating system that support the Media Transfer Protocol	
		Apple	Devices with the iOS operating system and the iAP2 protocol	HFS+
Bluetooth® player	Bluetooth®	-	Bluetooth® protocols A2DP and AVRCP (1.0 - 1.6)	-

Compatibility of mobile devices

It is possible to check the ŠKODAweb pages to see if Infotainment is compatible with the selected mobile device being tested. This check is carried out by using the following reference or by reading the QR code:

<http://go.skoda.eu/compatibility>



All information given is incidental and serves as information.

The ŠKODA AUTO company cannot guarantee full functionality and compatibility, e.g. due to a software update of the Infotainment and the mobile devices.

Supported audio files

Compression format	Codec type	File extension	Max. bit rate [kbps]	Max. sampling rate [kHz]	Multi channels
MPEG	MPEG 1 Layer 2	mp2	32 - 384	32, 44, 48	Mono, stereo, Joint stereo
	MPEG 2 Layer 2		8 - 160	16, 22, 24	
	MPEG 1 Layer 3	mp3	32 - 320	32, 44, 48	Mono, dual mono, Stereo, Joint Stereo
	MPEG 2 Layer 3		8 - 160	16, 22, 24	
	MPEG 2.5 Layer 3			8, 11, 12	

Compression format	Codec type	File extension	Max. bit rate [kbps]	Max. sampling rate [kHz]	Multi channels
WMA	Windows Media Audio 7	wma	6 - 192	8, 16, 22, 32, 44, 48, 96	Mono, stereo, Joint stereo
	Windows Media Audio 8		8 - 384		
	Windows Media Audio 9 and 9.1		8 - 768		
	Windows Media Audio 9.2		8 - 320		
	Windows Media Audio 10		32 - 768	32, 44, 48, 96	
ADTS	AAC LC	aac	16 - 2048	22, 24, 32, 44, 48	Stereo
	AAC HE			16, 22, 24, 32, 44, 48	
	AAC HEv2				
MP4	M4A LC	m4a	16 - 400	22, 24, 32, 44, 48	Stereo
	M4A HE			16, 22, 24, 32, 44, 48	
	M4A HEv2		16 - 64		
OGG	OGG-Vorbis	ogg	8 - 576	8, 11, 12, 16, 22, 24, 32, 44, 48, 96	Mono, Stereo
FLAC	FLAC	flac	-	8, 11, 12, 16, 22, 24, 32, 44, 48, 64, 88, 96, 192	Mono, stereo, Joint stereo
RIFF	WAV	wav	64 - 3072	8, 11, 12, 16, 22, 24, 32, 44, 48, 96	Mono, Stereo
Monkey's	Monkey's	ape	8 - 192		
SBC	Bluetooth A2DP	-	8 - 345	8, 11, 12, 16, 22, 24, 32, 44, 48	Mono, stereo, Joint stereo
OPUS	OPUS	opus	6 - 2000	8 - 48	Mono, stereo, Multichannel

Files that are protected by **DRM-** and **iTunes®** methods are not supported by Infotainment.

Supported video files

Codec type	File extension	Max. recordings per second bit rate [Mbit/s]
MPEG 1	mpg mpeg m1v mPV	1.5
MPEG 2	mpg mpeg ps m2v	15
MPEG 4 (H.264)	m4p mp4 m4v mp4v mov	50
MPJEG		
MPEG 4 (ISO)		
Xvid	Xvid	20

Codec type	File extension	Max. recordings per second bit rate [Mbit/s]
WMV9	wmv asf	50

Supported playlists

Codec type	File extension
M3U	m3u
M3U8	m3u8
PLS	pls
WPL	wpl
ASX	asx

Images

Overview

Display menu
 > Tap MENU >

Image viewer

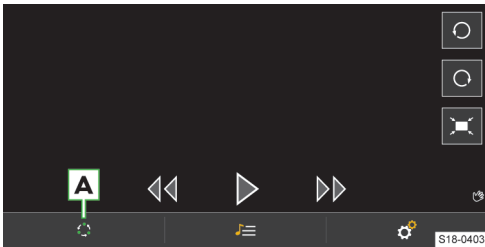

- A** Select source
- Manage files
- Settings

Operation

Operation using functional areas

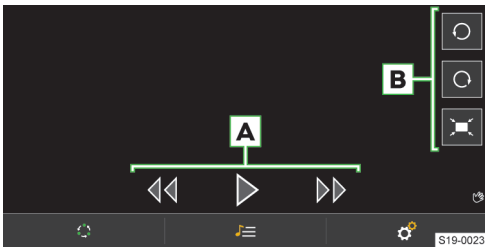

- A** View images
 - > >> Show the next image
 - > <<< Show the previous image
 - > ▶ Start slideshow

- > Stop slideshow
- B** View image
 - > ○ Turn left
 - > ○ Turn right
 - > Show in output size

Gesture control



> Display of the next image



> Display the previous image



> Increase the image size



> Reduce the image size



▶ Rotate by 90 °

Settings

The following Infotainment functions are set in the MENU > > menu:

- ▶ Display image size
- ▶ Display image duration during the slideshow
- ▶ Slideshow repeat

Supported sources and files

Supported sources

Source	Interface	Specifica- tion	File system
USB	USB 1.x; 2.x 3.x or higher with USB 2.x support	USB stick	VFAT
		HDD (without special software)	FAT16 FAT32 exFAT NTFS

Supported files

Codec type	File extension	Max. resolution [Mpx]
BMP	bmp	4
JPG; JPEG	jpg; jpeg	4 (Progressive Mode) 64
GIF	gif	4
PNG	png	4

The maximum supported image size is 20 MB.

Mobile device management

Cybernetic security

Your vehicle contains components that are used to exchange information and data between the vehicle and the connected mobile devices or the Internet.

These components have security mechanisms that minimise the risk of unauthorised access to the vehicle systems.

Regular software updates help reduce the risk of unauthorised access to vehicle systems and vehicle functions. The following guidelines must therefore be observed:

- ▶ Use only media carriers, Bluetooth® devices, and mobile devices that contain no harmful data or malware.
- ▶ Regularly update the software provided by ŠKODA AUTO.

We recommend having the system software and components updated by a specialist company.

⚠ WARNING

Risk of an accident!

Malware in the vehicle can influence and deactivate certain vehicle functions, or take over the controls of these where applicable.

- ▶ If the vehicle reacts in an unusual way, immediately reduce speed or stop the vehicle.
- ▶ Seek the help of a specialist garage.

⚠ WARNING

Malware in the vehicle may gain unauthorised access to the information and data of the vehicle, and on occasion, to connected mobile devices.

Overview

Using mobile device management, devices can be connected, disconnected, and interchanged.

Display mobile device management

- ▶ Tap on MENU > > Manage mobile devices.

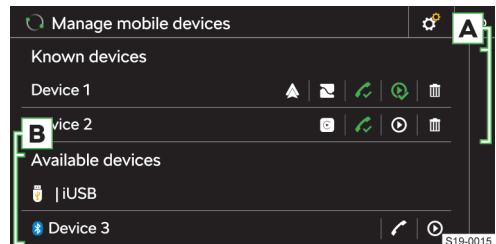

- ✓ The device enables a connection via the Bluetooth® "hands-free profile"
- ✓ The device is connected via the Bluetooth® "hands-free profile"
- ⊙ The device enables a connection via the Bluetooth® audio profile
- ⊙ The device is connected via the Bluetooth® audio profile
- ▣ Remove the device from the list **previously connected devices**
- ▲ The device enables a SmartLink connection to be made via Android Auto
- The device enables a SmartLink connection to be made via Apple CarPlay
- The device enables a SmartLink connection to be made via MirrorLink

A Connected / Previously connected devices

B Available devices

Limitations of mobile devices and applications

Availability of features

The availability of certain features depends on the type of mobile device, as well as that of the applications installed.

Compatibility of mobile devices

It is possible to check the ŠKODAweb pages to see if Infotainment is compatible with the selected mobile device being tested. This check is carried out by using the following reference or by reading the QR code:

<http://go.skoda.eu/compatibility>



All information given is incidental and serves as information.

The ŠKODA AUTO company cannot guarantee full functionality and compatibility, e.g. due to a software update of the Infotainment and the mobile devices.

Bluetooth® compatibility of mobile devices

Due to the large number of mobile devices, it is not possible to guarantee total Bluetooth® compatibility with Infotainment. Bluetooth® compatibility depends on the Bluetooth® version as well as the implementation of Bluetooth® protocols by the manufacturer of the mobile device.

Applications in mobile devices

Mobile devices can be used to install applications that allow you to view additional information on the Infotainment screen, or to operate the Infotainment system.

Due to the variety of applications, as well as their ongoing development, the available applications may not function on all mobile devices. ŠKODA AUTO assumes no liability for their proper functioning.

The scope of available applications and their functionality is dependent on the type of Infotainment, as well as the vehicle and country.

Information about ŠKODA applications

Detailed information about ŠKODA applications can be found on the website after reading the following QR code or link:

<http://go.skoda.eu/mobile-apps>



Connection set-up

Connect a mobile device to Infotainment

- › Find available Bluetooth® devices in the mobile device.
- › Select the Infotainment Bluetooth® unit.

The unit name can be determined by tapping **MENU** › › *Manage mobile devices* › › *device name*.

- › Confirm the PIN; enter it if necessary and then confirm.

Connect Infotainment to a non-paired mobile device

- › **MENU** › › *Manage mobile devices* .
- › Select the desired device from the list of **available devices**.
- › Select the desired Bluetooth® profile.
- › Confirm the PIN; enter it if necessary and then confirm.
- › If two devices are connected to the Infotainment, select the device to be replaced.

Connect Infotainment to a previously connected mobile device

- › **MENU** › › *Manage mobile devices* .
- › Select the desired device from the list of **previously connected devices**.
- › Select the desired Bluetooth® profile.
- › If two devices are connected to the Infotainment, select the device to be replaced.

SmartLink connection

Infotainment provides the ability to connect SmartLink to compatible mobile devices using the following connection types:

- ▲ Android Auto
- Ⓜ Apple CarPlay
- 📺 MirrorLink

Mobile devices can be connected to the Infotainment via USB cable or Wi-Fi, as long as the mobile device supports it.

- › Connect the mobile device to the Infotainment via a USB cable or browse and connect to a wireless network.
- › Tap the icon of the supported connection.

Telephone

Overview

Display menu

- › Tap **MENU** › .

If the menu **phone** is not displayed, check whether the mobile device is connected.

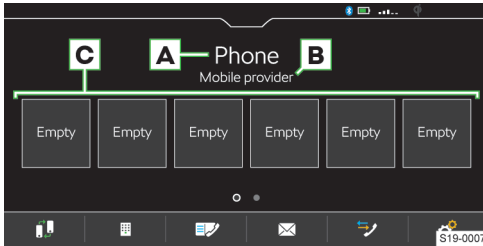

- A** Name of the connected telephone
 - ▶ **Tap:** Show list of previously connected phones
- B** Name of telephone service providers
 - ▶ If the symbol ▶ is displayed in front of the name, roaming is active.
- C** Preset buttons for preferred contacts
 - ☰ Change the main telephone with the additional telephone
 - ☰ Enter telephone number
 - ☰ Contact list
 - ✉ Text messages / emails
 - ☰ Call lists
 - ⚙ Settings

Conditions for connecting a telephone with Infotainment

- ✓ The Bluetooth® function of the Infotainment and the telephone needs to be switched on.

The Bluetooth® function of the Infotainment is switched on in the menu item **MENU** > ☰ > *Manage mobile devices* > ☰ > *Bluetooth*.
- ✓ Visibility of the Infotainment is switched on.

The visibility of the Infotainment is switched on in the menu item **MENU** > ☰ > *Manage mobile devices* > ☰ > *Visibility*.
- ✓ The telephone is within signal range of the Infotainment's Bluetooth® unit.
- ✓ The telephone is compatible with Infotainment.

Telephone operation

Enter telephone number

- ▶ In the **Phone** menu, tap on ☰.
 - ▶ Enter the telephone number using the numeric keypad that is displayed.
- I** The displayed numeric keypad can also be used for searching for contacts. If, for example, the digits 32 are entered, contacts with the letter sequence DA, FA, EB etc. are displayed next to the numeric keypad.

List of telephone contacts

The list of telephone contacts is imported from the connected main telephone.

- ▶ To **display** the contact list in the **phone** menu, tap on ☰.
- ▶ To **search** within the list, tap on *Enter contact*.
- ▶ Enter the details you wish to find.
- ▶ To **establish a connection** with a contact, tap the functional area showing the desired contact.

If a contact has multiple telephone numbers, select the telephone number from the displayed list.

- ▶ To display the **details** for a contact, tap >.

Establish a connection to the voice mailbox number

- ▶ In the **Phone** menu, tap on ☰ > ☰.

Telephone conversation

Depending on the context of the telephone conversation, the following functions can be selected:

- ☰ End connection / reject incoming call / end call
 - ☑ Answer an incoming call / return to the held call
 - 🔊 Switch the ringer off / on
 - 🔇 Hold a call
 - 🔇 Switch the microphone off / on
 - 👤 Show details of the caller
 - ✉ Reject an incoming call using an SMS message
 - ☑ Answer a call from the second telephone during a call on the first telephone
- The ongoing call on the first telephone is terminated by accepting the call.

- ▶ To **switch the call tone from the speakers to the telephone**, go to **telephone** in the menu and tap on ☰ > *speakerphone*.
- ▶ To **switch the call tone from the telephone to the speakers**, tap ▶.

Conference call

A conference call is a joint telephone conversation with a minimum of three and a maximum of six participants.

- ▶ Make the next call during an ongoing conversation / conference.



Or:

- ▶ Accept a new incoming call by tapping ☑.
- ▶ To **start** a conference call, tap ▶▶.



During an ongoing conference call, the following functions can be selected depending on the context:

- 🔇 Hold the conference call and leave temporarily (the conference will continue in the background)
- ☑ Return to the held conference call
- 🔇 Switch the microphone off / on
- ☰ End conference call
- 👤 Show details of the conference call





In the details of the conference call, depending on the connected telephone, the following functions can be selected:

-  Show details of the conference call participants
-  End conversation with the conference call participant
-  Conversation with a participant outside of the conference call



Send a text message

- › In the **Telephone**  >  menu, tap *Messages* >  *New SMS*.
- › Write a text message and confirm; a view of the message is displayed.
The message can be edited when the text area within the view is tapped.
- › Search for or select the recipient of the message.
- › Add more recipients or confirm selected recipients.
- › Tap on *Send*.



Display received text messages

- › In the **Telephone**  >  menu, tap *Messages* >  or .
- › Messages that are received are displayed as individual messages or as messages in a conversation, depending on the following setting.
To **switch the display of messages in a conversation on or off**, tap in the **Phone**  > menu *Show messages as conversation*.

- › To **switch graphic notifications** regarding the receipt of a new message **on or off**, tap in the **Phone**  > menu *New message notifications*.

 Infotainment offers the possibility to read the text message (context-dependent) by means of the generated Infotainment voice if  is tapped.

Send e-mails

- › In the **Telephone**  >  menu, tap *Emails* >  *New emails*.
- › Write an e-mail and confirm that an e-mail is displayed.
The text can be edited when the text area within the view is tapped.
- › Search for or select the recipient of the email.
- › Add more recipients or confirm selected recipients.
- › Enter the subject of the e-mail.
- › Tap on *Send*.

Show received e-mails

- › In the **Telephone**  >  menu, tap *Emails* > .
- › Select the desired e-mail.

- › To **switch graphic notifications** regarding the receipt of a new email **on or off**, tap in the **Phone**  > menu *New message notifications*.

Settings for Infotainment telephone functions



Telephone-Infotainment-Connection types

The way in which the telephone is connected depends on the number of phones currently connected to the Infotainment:

- ▶ **No telephone** - The telephone is connected as a main telephone.
- ▶ **One telephone** - The telephone is connected as an additional telephone.
- ▶ **Two telephones** - Select the telephone to be replaced.
- › To **switch between the main telephone and the additional telephone**, tap on  in the **Phone** menu.

Connect the telephone to Infotainment

- › Find available Bluetooth® devices on the phone.
- › Select the Infotainment Bluetooth® unit.

The unit name can be determined by the menu item **MENU** >  > *Manage mobile devices* >  > *Device name*.

- › Confirm the PIN; enter it if necessary and then confirm.

Connect Infotainment to a non-paired telephone - no telephone is connected

- › Tap on **PHONE**.

Or:

- › Tap on **MENU** > .
- › Follow the instructions in the Infotainment screen.

Connecting Infotainment to a non-paired telephone - another telephone is connected

- › Tap on **MENU** >  > *Manage mobile devices*.
- › Select the desired device from the list of **available devices**.
- › Select the desired Bluetooth® profile.
- › Confirm the PIN; enter it if necessary and then confirm.

The telephone is connected as an additional telephone.

Or:

- › If two telephones are connected to the Infotainment, select the telephone to be replaced.

Connect Infotainment to a previously paired telephone

- › **MENU** >  > *Manage mobile devices*.

Or:

PHONE >  > *Select mobile phone*.

- › Select the desired device from the list of **previously connected devices**.

The telephone is connected as an additional telephone.

Or:

- > If two telephones are connected to the Infotainment, select the telephone to be replaced.

Manage preset buttons for preferred contacts

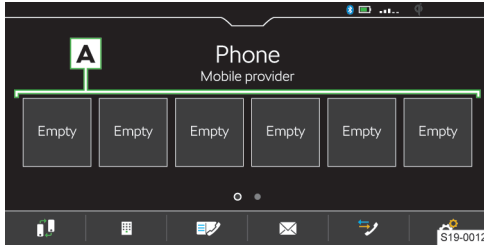

- > To **save** the desired preset button, hold **A**.
- > Select a contact from the displayed list.
- > If the contact contains multiple telephone numbers, choose the desired telephone number.
- > To **display the menu for deletion**, go to the **phone** menu > and tap on *Manage favourites* .

- > To delete **one** preset, tap on the list entry and confirm the deletion.

Or:

- > To delete **all** station buttons, tap *Clear all* and confirm the deletion.

Import telephone contacts

After first connecting the main telephone with Infotainment, telephone contacts will start to be imported into the Infotainment memory.

Infotainment can import up to 5000 telephone contacts together with contact pictures. Each contact can include max. 5 telephone numbers.

Depending on the type of telephone, import confirmation may be required.

Update telephone contacts

When re-connecting the telephone with Infotainment, an **automatic** update of the list is carried out.

- > For **manual** update of the list in the **phone** > menu tap on *Import contacts* .

Sort contacts in the phone book

- > In the **Telephone** > menu *Sort by:* Tap and select the sorting type.

Ringtone

Some phones do not allow the use of the telephone ringtone; instead, the Infotainment ringtone is used.

- > For **setting the Infotainment ringtone** in the **phone** > menu *select the ringtone* .
- > Select the ringtone.

Number for the voice mailbox

- > For **setting the voice mailbox number** in the **phone** > menu *Mailbox number:* .
- > Enter the voice mailbox number.

Turn the graphic notice regarding receiving a new message/email on or off

When the feature is on, the new message icon appears on the status bar and in the feature area for the messages when a new message/e-mail is received.

- > In the **Telephone** > menu *New message notifications* .

Simultaneous calls

This applies to some countries.

Depending on the connected telephone, it is possible to answer the next incoming call and hold the previous call.

- > To switch on simultaneous calls, tap on **telephone** > *Parallel talks*.

Wi-Fi

Functionality

The Wi-Fi can be used for the internet connection or for the SmartLinkConnection.

The Infotainment hotspot can connect up to 8 mobile devices. At the same time, the Infotainment can be connected to another hotspot.

- > To display the list of connected mobile devices, tap **MENU** > > *Wi-Fi* > *Infotainment system as hotspot* > *Connected devices*.

Overview of available hotspots

Display available hotspots

- > Tap **MENU** > > *Wi-Fi* > *Wi-Fi*.

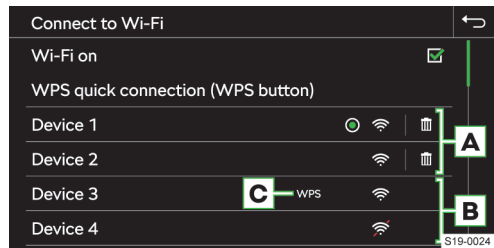

- A** Previously connected hotspots
- B** Available hotspots
- C** The hotspot supports the WPS connection
- Currently connected hotspot
- ⌵ Delete information about the hotspot connection

- 📶 Wi-Fi signal strength of the hotspot
- 📶 The Wi-Fi signal from the hotspot is not available

Function restriction

The Infotainment system can only be connected to a hotspot with WPA2 access protection.

Restriction of the Wi-Fi connection

In some countries, the Wi-Fi connection is restricted for legal reasons. When crossing the border of the country in question, the connection with a mobile device connected via Wi-Fi can be ended or restricted.

I Find out about country-specific legal restrictions. If necessary, switch off the Wi-Fi manually.

Settings

Connect a mobile device to the Infotainment hotspot

- Turn on the Infotainment's Wi-Fi hotspot in the menu item **MENU** > 📶 > Wi-Fi > Infotainment system as hotspot > Use as hotspot.
- Turn on the Wi-Fi on the mobile device.
- In the list of available Wi-Fi devices, look for Infotainment Wi-Fi.

The name of the Infotainment is taken from the menu item **MENU** > 📶 > Wi-Fi > Infotainment system as hotspot > Network name.

- Select the Infotainment hotspot and enter the required password.

The password for connecting to the Infotainment hotspot is taken from the menu item **MENU** > 📶 > Wi-Fi > Infotainment system as hotspot > Network key.

- Confirm the connection.

Connect Infotainment to the mobile device hotspot

- Turn on the Infotainment's Wi-Fi unit in the menu item **MENU** > 📶 > Wi-Fi > WLAN: > WiFi active switch on
- Select the desired hotspot in the list of available hotspots.
- Enter the password for connecting to mobile devices.

I Infotainment stores passwords for previously connected hotspots.

Security level of the Infotainment hotspot

The security level is set at WPA2 and cannot be changed.

Activate/deactivate data transfer between the Infotainment and the connected device

- To turn data transmission on or off, tap **MENU** > 📶 > Wi-Fi > Infotainment system as hotspot > Connected devices > 📶.

Change the name of the Infotainment hotspot

- ▶ Tap **MENU** > 📶 > Wi-Fi > Infotainment system as hotspot > Network name..
- ▶ Enter the name and confirm.

Change password for connection to Infotainment hotspot

The password must be a minimum of 12 and a maximum of 63 characters.

- ▶ **MENU** > 📶 > Wi-Fi > Infotainment system as a hotspot > Network key .
- ▶ Enter and confirm the password.

Quick connection of Infotainment to the mobile device hotspot

- On the mobile device, turn on the hotspot, its visibility, and the option for WPS connection.
- **MENU** > 📶 > Wi-Fi > Wi-Fi: Tap > WPS quick connection (WPS button).

Automatic WPS connection

- Tap **MENU** > 📶 > Wi-Fi > Quick connection to Infotainment system.
- In the mobile device, switch on the option for connection via WPS.
- Wait for the connection to be established and, if necessary, confirm the respective messages.

Manual WPS connection

- In the mobile device, switch on the option for connection via WPS PIN.

The mobile device display will show the WPS PIN for connecting to the Infotainment.

- Tap **MENU** > 📶 > Wi-Fi > Quick connection to Infotainment system > 📶 > WPS PIN.
- Enter the WPS PIN in the Infotainment and confirm.
- Wait for the connection to be established and, if necessary, confirm the respective messages.

Automatic connection using the QR code

- **MENU** > 📶 > Wi-Fi > Tap quick connection with infotainment system .
- In the mobile device, switch on the option for connection via QR Code.
- With the mobile device, read the QR code displayed on the Infotainment screen.
- Wait for the connection to be established and, if necessary, confirm the respective messages.

Tips for a perfect connection

- I**
- ▶ Keep only the hotspot to be connected switched on and switch off the other hotspots.
- ▶ Delete unused hotspots. This shortens the time required to establish a connection.
- ▶ For some hotspots, the connection takes longer, so wait for the connection to finish.
- ▶ If the connection is interrupted, recheck the available hotspots and repeat the connection.

SmartLink

Functionality

SmartLink offers the ability to display and operate certified applications from a connected mobile device in the Infotainment screen.

Certification may be conditional upon the use of the latest update to the particular SmartLink application.

Applications include, for example, apps for route guidance, telephoning, listening to music, etc.

Mobile devices can be connected via a USB cable or WiFi.

Supported connection types

SmartLink supports the following connection types:

- ▶ Android Auto
- ▶ Apple CarPlay
- ▶ MirrorLink

Overview of the SmartLink connection

Display menu

▶ Tap MENU ▶

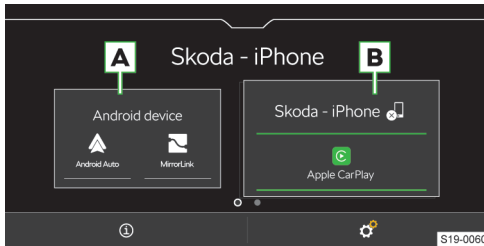

- A** Previously connected device
- B** Currently connection device
- Display information about SmartLink
- Disconnection of the active connection
- Settings in SmartLink menu

Android Auto

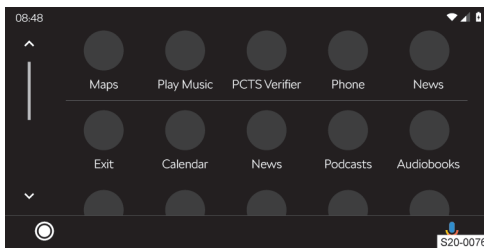

- Overview of running applications, phone calls, received text messages and the like.

- Switching on voice control (Google Voice)

Apple CarPlay

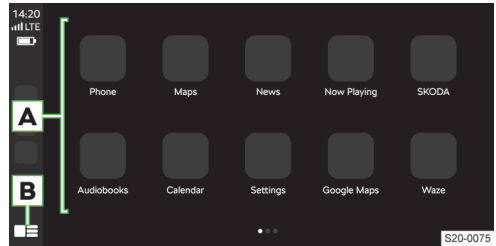

- A** List of available applications
- B** Depending on the duration of operation:
 - ▶ **Tap:** Return to the menu Apple CarPlay
 - ▶ **Hold:** Turn on voice control (Siri)

MirrorLink

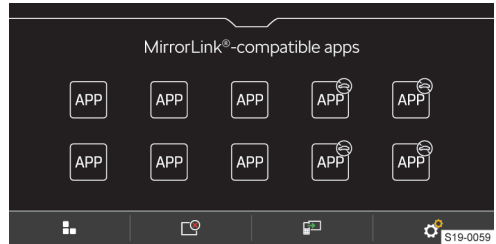

- It is not possible to operate the application while driving
- Return to the menu SmartLink
- List of running applications
- Display of the last running application in connected mobile devices
- Settings

Connection conditions

General connection conditions

- ✓ The mobile device supports the type of SmartLink connection Android Auto, Apple CarPlay or MirrorLink.
- ✓ Mobile devices, as well as the type of SmartLink connection, are supported in the respective market.
- ✓ Some connected mobile devices require the mobile device to be "unlocked".

Conditions for Android Auto

- ✓ The device to be connected must have Android Auto connection.

A list of devices, supported regions and applications that support the Android Auto connection can be found on the Google, Inc. website.

- ✓ The Android Auto application needs to be installed on the mobile device.
- ✓ Some applications require the data connection in the mobile device to be turned on.
- ✓ Connect the mobile device for the first time when the vehicle is stationary.

Conditions for Apple CarPlay

- ✓ The device to be connected must have Apple CarPlay connection.

A list of devices, supported regions and applications that support the Apple CarPlay connection can be found on the Apple Inc website.

- ✓ Siri voice control is on.
- ✓ The data connection in the mobile device is switched on.

Conditions for MirrorLink

- ✓ The device to be connected must have MirrorLink connection.

A list of devices and applications that support the MirrorLink connection can be found on the websites of Car Connectivity Consortium®.

- ✓ The MirrorLink application needs to be installed on the mobile device.
- ✓ Some applications require the data connection in the connected mobile device to be turned on.

Operation

Operation of the running MirrorLink application

- Display of control surfaces at the bottom
- Display of control surfaces at the top
- ☰ Return to the menu MirrorLink

Restriction

Restriction of the Wi-Fi connection

In some countries, the Wi-Fi connection is restricted for legal reasons. When crossing the border of the country in question, the connection with a mobile device connected via Wi-Fi can be ended or restricted.

- ℹ Find out about country-specific legal restrictions. If necessary, switch off the Wi-Fi manually.

Restriction of SmartLink applications while driving

For reasons of safety, the operation of some SmartLink applications while driving is not possible or only limited.

Restriction of the navigation function

If route guidance is currently being carried out through Infotainment, this is ended when you start route guidance in the Apple CarPlay application.



If there is route guidance in the Apple CarPlay application, it is ended by starting the destination guidance using Infotainment.

SmartLink settings

Apple CarPlay - Connection via USB

- Turn on the Infotainment.
- Turn on the mobile device.
- Connect the mobile device to the front USB input using a cable.
- Choose to connect via Apple CarPlay.

Apple CarPlay - Connection via Wi-Fi from Infotainment

- Turn on Bluetooth® and Bluetooth® visibility in the Apple mobile device.
- Tap on **MENU** >  > *Manage mobile devices*.
- In the displayed list, look for and select the desired device with the symbol .
- Follow the instructions on the Infotainment screen and confirm the Bluetooth® pairing.
- If another device is connected to the Infotainment, select the device to be replaced.

Apple CarPlay - Connect via Wi-Fi from mobile devices

To establish a connection, the following conditions must be met:

- ✓ The minimum iOS version is 9.
- ✓ No other mobile device can be connected via SmartLink.
- ✓ Wi-Fi and Bluetooth® functionality is switched on in the Infotainment system.
- In the mobile device, turn on the CarPlay function.
- Press and hold the  button on the multifunction steering wheel.

The Infotainment screen displays a connection message with the name of the Bluetooth® unit of the Infotainment.

- Find available Bluetooth® devices on the phone.
- Select the Infotainment Bluetooth® unit.
- If necessary, confirm the PIN.
- In the Infotainment screen, select the connection type Apple CarPlay.



Apple CarPlay - Disconnect

- In the Apple CarPlay menu, tap on the function area "ŠKODA".
- Tap on .

Android Auto - Connection via USB

- › Turn on the Infotainment.
- › Turn on the mobile device.
- › Connect the mobile device to the front USB input using a cable.
- › Choose to connect via Android Auto.

Android Auto - Connection via Wi-Fi from Infotainment



- › Tap on **MENU** ›  › *mobile devices*.
- › Select the desired device from the list of **available devices**.
- › Select the Bluetooth® hands-free profile.
- › Confirm the PIN; enter it if necessary and then confirm.
- › If another device is connected to the Infotainment, select the device to be replaced.
- › From the list of **known devices**, select the desired device with the  symbol.

Android Auto - Connect via Wi-Fi from mobile devices

To establish a connection, the following conditions must be met:

- ✓ The minimum Android version is 5.
- ✓ No other mobile device can be connected via SmartLink.
- ✓ Wi-Fi and Bluetooth® functionality is switched on in the Infotainment system.
- › Find available Bluetooth® devices on the phone.
- › Select the Infotainment Bluetooth® unit.
- › If necessary, confirm the PIN.
- › In the Infotainment screen, select the connection type Android Auto.



Android Auto - Disconnect

- › In the Android Auto  › menu, tap "Return to SKODA".
- › Tap on .

MirrorLink - Connection via USB

- › Turn on the Infotainment.
- › Turn on the mobile device.
- › Connect the mobile device to the front USB input using a cable.
- › Choose to connect through MirrorLink.

MirrorLink - Disconnect

- › In the MirrorLink menu, tap on .
- › Tap on .

Change to another device / connection type

Infotainment allows you to switch between currently connected devices and the connection type.

- › Tap on **MENU** › .
- › Select the desired device or connection type.

Navigation

Navigation announcements

Infotainment route guidance takes place using graphic driving recommendations and navigation announcements.

The navigation announcements are generated by the Infotainment system. Navigation announcement clarity (e.g. road or city name) cannot always be guaranteed.

Repeat the last navigation announcement

- › Tap on .

Turn off navigation announcements

- › Tap on .





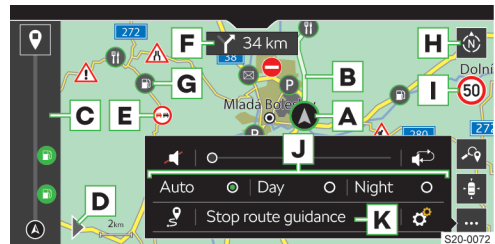

Navigation overviews

Display menu

- › Tap **MENU** › .

Map overview



- A** Vehicle position
- B** Route
- C** Route view
-  End route guidance
- D** Display the destination input and route view menu
- E** Traffic obstruction
- F** Following driving recommendation
- G** POI
- H** Change map orientation
 - ▶ North-facing 2D map
 - ▶ 2D map facing the direction of travel
 - ▶ 3D map facing the direction of travel
- I** Road signs for the affected route section
-  Find destination
-  Centre the map on the vehicle position
-  **Display the settings menu**
-  Turn off navigation announcements
-  Repeat the last navigation announcement

☰ Show the default map

J Display map in accordance with the following setting

- ▶ Auto - Map in day / night mode depending on the vehicle lighting currently switched on
- ▶ Day - Map in day mode
- ▶ Night - Map in night mode

📍 Show the entire route

K End route guidance

⚙ Settings

Find destination

› Tap ▶ > 📍.

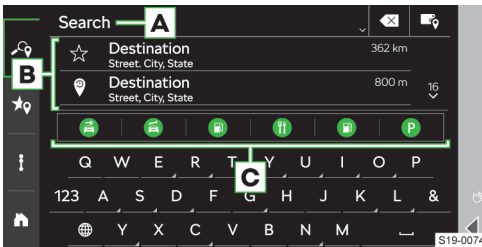

A Input line

B List of recently searched destinations

C POI categories

› Tap: search for the selected category

⌵ Show destination list

📍 Enter destination via address / find destination

Select the destination you are looking for

- › Enter the details for the destination search.
- › Select the desired destination.

Destination details are displayed with the option of starting route guidance.

Selecting the destination entered via the address

› Tap on 📍.

A menu for entering the destination via the address is displayed.

› Enter the required information.

Destination details are displayed with the option of starting route guidance.

List of stored destinations

› Tap on ▶ > 📍.

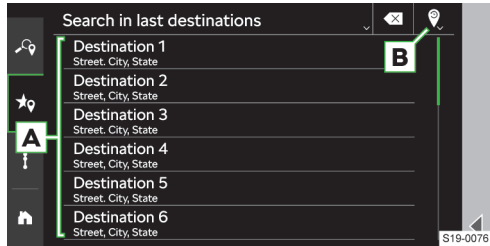

A List of stored destinations

B Select category of stored destinations

- ▶ 📍 - Favourites
- ▶ 📍 - Last destinations
- ▶ 📞 - Telephone contact destinations

Selecting the stored destination

- › Select the category of stored destinations.
- › Select the desired destination.

Destination details are displayed with the option of starting route guidance.

Recommended destinations

› Tap on ▶ > 🏠.

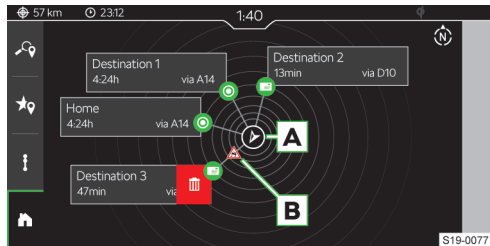

A North-facing vehicle position

B Traffic obstruction

☒ Delete the recommended destination

The view can display up to 5 recommended destinations in the following categories:

- ▶ Destination – home address
- ▶ Destination – business address
- ▶ Favourites
- ▶ Last destinations

Destination alignment depends on the direction in relation to the current vehicle position. The functional surface with the destination displays information about the estimated travel time to the destination.

If the vehicle has active online services and there is a traffic obstruction on the route to the destination, the traffic obstruction icon will be displayed.

Delete the recommended destination

- › Touch the functional surface for the recommended destination and swipe left.
- › Tap on .

Selecting destination by tapping the map point

- › Tap the desired item or the POI icon in the map.

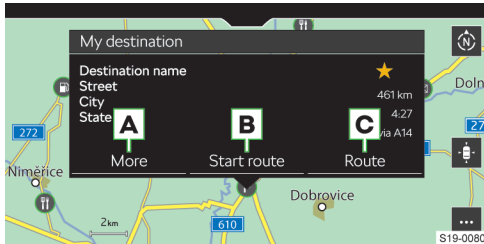



- A** Show destination details with the following possible settings:
 - ▶ ☆ - Save destination as a favourite
 - ▶ ★ - Delete favourites
 - ▶  - Set destination as a starting point for route guidance in demo mode

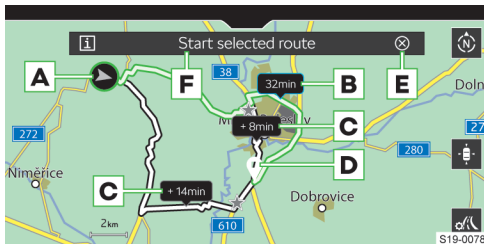

- B** Start direct route guidance
- C** Route calculation

Route calculation



- A** Current vehicle position
- B** Proposed fastest route
- C** Alternative routes
- D** Destination position
- E** 15 s time countdown before automatic start of the route guidance
 - › **Tap:** Interrupt time countdown
- F** Start route guidance
 -  Show information on the selected route
 -  Set parameters for route calculation

Route overview

- › Tap on  > .

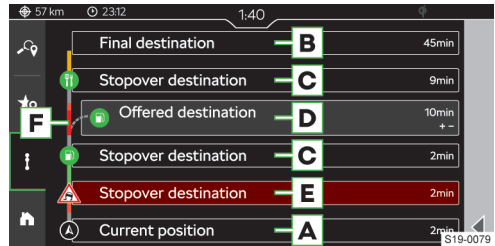

- A** Information on current vehicle position
- B** Final route destination
 - Tap:** the following menu items can be selected:
 - › Show on map
 - › Stop route guidance
- C** Route stopover
 - Tap:** the following menu items can be selected.
 - › Show on map
 - › Add stopover destination
- D** Destination provided by Infotainment on the route
 - Tap:** the following menu items can be selected.
 - › Show on map
 - › Delete
- E** Traffic obstruction on the route
 - Tap:** the following menu items can be selected.
 - › Show on map
 - › Avoid
- F** Route view

Changing route destinations

In the route overview, it is possible to exchange the destination and the intermediate destinations with each other and thus change their order.

- › Hold the line with the desired destination until the functional surface for the destination becomes free.
- › Move the destination to the desired position and release the functional surface.

The route is re-calculated.

Overview of traffic density

When ŠKODA online services are activated, traffic density information can be displayed in the form of the following colour scale in the route view **F**.

Low density    **High density**

— Traffic density information is not available

Touch operation

Gesture control



▶ Move map

S19-0674



▶ Enter destination by tapping the map item

S19-0662

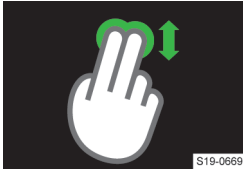

▶ Switch 2D/3D map display

S19-0669



▶ Zoom into the map

S19-0667



▶ Zoom out of the map

S19-0668



▶ Rotate the map

S19-0666

Limitation

Infotainment may give incorrect driving recommendations if the road conditions or the traffic do not match the navigation data. This can lead to the route guidance being carried out using a different route or proposing a change of direction in a one-way street.

Information for updating the navigation data must be requested from a ŠKODA partner.

Settings

Avoiding traffic obstructions

If the function is switched on and the Infotainment receives information about a traffic obstruction on the route from online traffic information, the route is recalculated.

Infotainment may suggest a detour to avoid traffic obstructions, depending on the following settings:

- ▶ ... > > Route guidance > Tap on Avoid traffic incidents .
- ▶ Select the desired menu item.

Showing information on the destination / waypoint

The status line displays information on the distance and travel time to the destination, depending on the following setting.

- ▶ ... > > Route guidance > Show information for: .
- ▶ Select the desired menu item for the destination type.

Showing arrival time information in the destination / driving time

The status line displays information on the travel time depending on the following setting.

- ▶ ... > > Route guidance > Time display: .
- ▶ Select the desired menu item.

Switching display of country-specific speed limits on / off

When the function is switched on, the country-specific speed limits are displayed when crossing national borders.

- ▶ Tap ... > > Route guidance > Country information at border crossings.

Switching the display of road signs on motorways and expressways on / off

When the function is switched on, Infotainment displays traffic and information signs on motorways and expressways.

- ▶ Tap ... > > Route guidance > Information signs on motorways and dual carriageways.

Switching the fuel warning on / off

When the function is switched on and the fuel supply reaches the reserve area, a warning message appears with the option of going to the nearest petrol station.

- ▶ Tap ... > > Route guidance > Fuel warning.

Switching the speed limit warning on / off

- ▶ Tap ... > > Route guidance > Road signs.
- ▶ Set the note type and the value for exceeding the permissible speed.

Settings for trailer operation

To calculate the correct route for trailer operation, switch on trailer inclusion.

- ▶ Tap ... > > Route guidance > Trailer > Include trailer.

Set the maximum speed for trailer operation to correctly calculate the route time.

- › Tap ... ›  › Route guidance › Trailer › Maximum speed for trailers.
- › Set the maximum speed for the trailer.

Setting navigation announcements

- › Tap ... ›  › navigation announcements.
- › Select and set the desired menu item.

Show preferred POI categories

Favourite POI categories are displayed on the map and provided in the destination search.

- › Tap ... ›  › Basic functions › Define preferred POI categories.
- › Set favourite categories.

Setting home address

The defined destination of the home address is displayed in the overview of recommended destinations.

- › Tap ... ›  › Basic functions › Enter home address.

Setting business address

The defined destination of the business address is displayed in the overview of recommended destinations.

- › Tap ... ›  › Basic functions › Enter business address.

Switching demo mode on / off

In demo mode, the route guidance from the starting point of the demo mode to the selected destination is simulated.

When the function is switched on, Infotainment issues a query before the start of route guidance as to whether the route guidance should be carried out in the normal way or in demo mode.

- › ... ›  › Tap on Basic functions › Demo mode .

Defining the starting point of the demo mode

- › Select or locate the desired destination to be the starting point of demo mode.
- › In the displayed destination details, tap More › .

Updating the navigation database

Information for updating the navigation database must be requested from a ŠKODA partner.

Automatic update

Infotainment automatically carries out an update if the following conditions are met:

- ✓ The "Infotainment Online" online services are activated.
- ✓ An update of the navigation database for the current vehicle position or route destination is available.

Determining the navigation database version

- › Tap MENU ›  › System information.

Online Services

ŠKODA Connect

Regulations

The rights and obligations of the contracting parties with regard to the provision of these services are regulated in an independent agreement. Current legal documents regarding the ŠKODA Connect services can be found on the ŠKODA Connect Portal and the ŠKODA Connect application.

Functionality

ŠKODA Connect services allow you to connect the vehicle to the online world. They thus represent an extension of the vehicle and Infotainment functions.

The ŠKODA Connect services are not part of the vehicle's equipment. These will be published separately on the ŠKODA Connect Portal website, in the ŠKODA Connect application or in Infotainment, if Infotainment allows this.

The offer of ŠKODA Connect services depends on the type of vehicle and its trim level, Infotainment and country.

ŠKODA Connect website

The ŠKODA Connect website contains e.g. the current information on the ŠKODA Connect services, the reference to the ŠKODA Connect Portal or the option to download the ŠKODA Connect application.

The website is opened after reading the following QR code or the reference:

 <http://go.skoda.eu/skoda-connect>



ŠKODA Connect Portal website

The ŠKODA Connect Portal website enables, for example, user registration, ordering of ŠKODA Connect services, service management or remote access to the vehicle.

The website is opened after reading the following QR code or the reference:

 <http://go.skoda.eu/connect-portal>



Requirements

Terms of use of the ŠKODA Connect services

Applies to Infotainment Swing.

- ✓ A user is registered in the vehicle.
- ✓ The ŠKODA Connect services are active.
- ✓ A registered user is authorized to use the ŠKODA Connect services.
- ✓ The protection level set for sending personal data enables the use of the ŠKODA Connect services.

Terms of use of the ŠKODA Connect services

Applies to Infotainment Bolero, Amundsen and Columbus.

- ✓ A main user is registered in the vehicle.
- ✓ The ŠKODA Connect services are active.
- ✓ A currently logged in user is authorized to use the ŠKODA Connect services.
- ✓ The protection level set for sending personal data enables the use of the ŠKODA Connect services.

Availability of the ŠKODA Connect services

Availability depends on the following conditions:

- ▶ Cellular networks through which the connection to the ŠKODA Connect services is ensured are available.
 - ▶ The availability, functioning, connection speed and technology used in the mobile network can be different in the respective countries and are dependent on the mobile network operator.
 - ▶ In areas where this is insufficient signal, e.g. in underground garages, functionality may be limited.
- ▶ The ŠKODA Connect services are available for your vehicle, infotainment and the respective country.
- ▶ The availability can be checked on the following ŠKODA Connect website:

<http://go.skoda.eu/skoda-connect-availability>



Availability status of the ŠKODA Connect services

The availability of the services is indicated by the colour of the  symbol in the status bar on the Infotainment screen.

- ▶ **White** - ŠKODA Connect services are available.
- ▶ **Grey** - ŠKODA Connect services are not available.

ŠKODA Connect application

Functionality

ŠKODA Connect application

The ŠKODA Connect application enables, for example, user registration, ordering of ŠKODA Connect services or remote access to the vehicle.

The application can be downloaded to the mobile device after scanning the following QR code or link:

<http://go.skoda.eu/skodaconnectapp>



Requirements

- ✓ The user has one ŠKODA ID account linked to the vehicle.
- ✓ The ŠKODA Connect services are active in the vehicle.

User registration and activation of the ŠKODA Connect services

Functionality

Applies to Infotainment Swing.

User registration will provide you with a ŠKODA ID user account that can be used in all ŠKODA applications and services.

User registration for the ŠKODA Connect services can be done at the following locations.

- ▶ ŠKODA Connect Portal website
- ▶ ŠKODA Connect application

Applies to Infotainment Bolero, Amundsen and Columbus.

User registration will provide you with a ŠKODA ID user account that can be used in all ŠKODA applications and services.

User registration for the ŠKODA Connect services can be done at the following locations.

- ▶ ŠKODA Connect Portal website
- ▶ ŠKODA Connect application
- ▶ Infotainment, if it supports this function

 When registering, create an S-PIN.

You will need the S-PIN to register for certain ŠKODA Connect services as well as to register for the protected user account.

Settings

User registration

Applies to Infotainment Swing.

User registration and activation of online services ŠKODA Connect take place on the website ŠKODA Connect Portal or in the application ŠKODA Connect.

I To complete registration, access to the e-mail box entered during registration is required.

Activation of online services

Applies to Infotainment Swing.

In order to aktivieren ŠKODA Connect online services, proceed as follows:

- › Turn on the ignition and switch on Infotainment.
- › Select the following menu:

MENU >  > ŠKODA Connect (Online Services) > Registration.



- › Enter and confirm the registration PIN you have received during user and vehicle registration on the ŠKODA Connect Portal website or in the ŠKODA Connect application.
- › Wait for the registration completion message to appear.
- › Confirm any messages on the screen.

Register users in Infotainment

Applies to Infotainment Bolero, Amundsen and Columbus.

- › Switch on the Infotainment and in the displayed welcome window tap *Switch users* > *Register* and follow the instructions on the screen.

Or:

- › **MENU** >  >  > *New user* > *Register* and follow the instructions on the screen.

I To complete registration, access to the e-mail box entered during registration is required.

Activate ŠKODA Connect services when registering the main user

Applies to Infotainment Bolero, Amundsen and Columbus.



After the main user has been registered, the Infotainment prompts you to activate ŠKODA Connect services.

To complete the activation, it is necessary to have two original vehicle keys with you.

- › Follow the instructions in the Infotainment screen.

Activate ŠKODA Connect services of another logged in user

Applies to Infotainment Bolero, Amundsen and Columbus.

- › **MENU** >  >  > *Become primary user*.

- › Follow the instructions in the Infotainment screen.

Setting personal data protection

Personal data

Personal customer data is collected, processed and used by ŠKODA AUTO in accordance with the provisions of the generally binding legal provisions.

The current declaration on the protection of personal data can be found on the following website:

 <http://www.skoda-auto.com/other/personal-data>



As a contracting party with regard to the use of the ŠKODA Connect services, you must ensure the protection of personal data and the right to privacy.

Inform the vehicle user and passengers that the vehicle is transmitting user data and using localization services. Failure to provide information can violate the rights of vehicle users and passengers.

Localisation services include, for example, information on the last parking position, area notification or speed notification.

If the passengers do not agree to the use of the localization services, switch off the services by setting the respective protection level for personal data.

Functionality

User and vehicle data as well as information from the localization services are sent when using the ŠKODA Connect services.

The level of protection for personal data set influences what is sent.

Applies to Infotainment Bolero, Amundsen and Columbus.

The set level of protection for personal data influences data transmission using eSIM.

This does not affect data transmission of a device connected via WLAN.

Settings

The legally required services, e.g. emergency call, cannot be switched off.

Every vehicle user can set the protection level of personal data.

it is necessary to activate localisation services for the full function of some ŠKODA Connect services.

Applies to Infotainment Bolero, Amundsen and Columbus.

The level of protection of personal data is linked to the user account. After the user has logged on, this is set according to the level last set.

Settings in the control centre

Applies to Infotainment Swing.

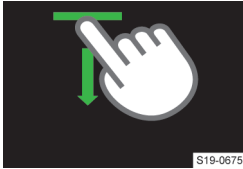

› Open the Infotainment control centre by holding down the bar at the top of the screen and pulling it down.

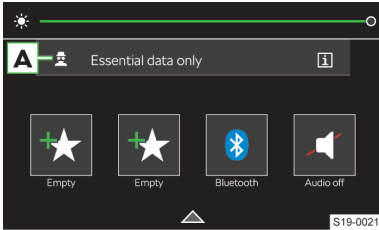

Example of display in Infotainment Swing

A Tapping the icon displays a menu for setting the protection level of personal data.

① Detailed information on the protection levels of personal data

Settings in the control centre

Applies to Infotainment Bolero, Amundsen and Columbus.

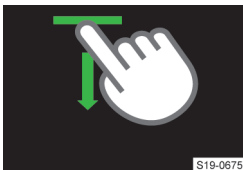

› Open the Infotainment control centre by holding down the bar at the top of the screen and pulling it down.

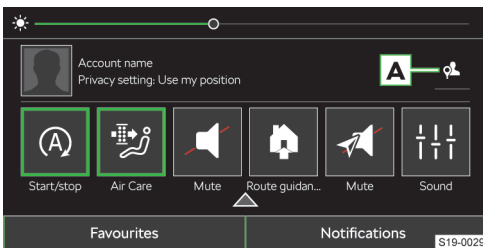

Display example in Infotainment Amundsen

A Tapping the icon displays a menu for setting the protection level of personal data.

Set the level of protection for personal data

Applies to Infotainment Swing.

› MENU > ⚙ > ŠKODA Connect (online services) > Privacy and services .

› Set the desired level of protection of personal data.

Tap Set-up in user management

Applies to Infotainment Bolero, Amundsen and Columbus.

› MENU > 👤 > ⚙ > Privacy and service management .

› Set the desired level of protection of personal data.

👤 Maximum privacy

Applies to Infotainment Swing.

▶ All ŠKODA Connect services other than the services you are currently using are switched off.

▶ All localization services are switched off. The vehicle position information is not shared.

👤 No location

Applies to Infotainment Bolero, Amundsen and Columbus.

▶ All ŠKODA Connect services other than the services you are currently using are switched off.

▶ All localization services are switched off. The vehicle position information is not shared.

▶ Information transmission via eSim is switched off.

▶ No online updates available.

👤 No location

Applies to Infotainment Swing.

▶ All localization services ŠKODA Connect are switched off. The vehicle position information is not shared.

👤 No location

Applies to Infotainment Bolero, Amundsen and Columbus.

▶ All localization services ŠKODA Connect are switched off. The vehicle position information is not shared.

▶ Information transmission via eSim is switched on.

▶ All functions that require a connection via eSIM are active.

👤 Use location

Applies to Infotainment Swing.

▶ Localization services ŠKODA Connect are enabled. Information on vehicle position is not provided to other people.

▶ Information on the vehicle position is not available on the ŠKODA Connect Portal web pages and in the ŠKODA Connect application.

📍 Use location

Applies to Infotainment Bolero, Amundsen and Columbus.

- ▶ Localization services ŠKODA Connect are enabled. Information on vehicle position is not provided to other people.
- ▶ Information on the vehicle position is not available on the ŠKODA Connect Portal web pages and in the ŠKODA Connect application.
- ▶ Information transmission via eSim is switched on.
- ▶ All functions that require a connection via eSIM are active.

📍 Share my location

Applies to Infotainment Swing.

- ▶ Localization services ŠKODA Connect are enabled. The vehicle position information is available for all services which need to know the vehicle's position.
- ▶ Information on the vehicle position is available on the ŠKODA Connect Portal web pages and in the ŠKODA Connect application.

📍 Share my location

Applies to Infotainment Bolero, Amundsen and Columbus.

- ▶ Localization services ŠKODA Connect are enabled. The vehicle position information is available for all services which need to know the vehicle's position.
- ▶ Information on the vehicle position is available on the ŠKODA Connect Portal web pages and in the ŠKODA Connect application.
- ▶ Information transmission via eSim is switched on.
- ▶ All functions that require a connection via eSIM are active.

Collection of anonymised data

Applies to Infotainment Bolero, Amundsen and Columbus.

When the protection level of personal data is set **📍 Use location** and **📍 Share my location** the vehicle can collect and send anonymised data to improve the services of selected third parties.

It is exclusively anonymous data without any connection to the specific vehicle, the vehicle owner or other authorized users.

User management**What you should be mindful of**

Applies to Infotainment Bolero, Amundsen and Columbus.

When buying an older vehicle with ŠKODA Connect services, it is possible that the services are active and the main user is the previous owner of the vehicle. The previous owner can still have the possibility to control the vehicle functions and receive information about the users and the vehicle.

Therefore, we recommend deleting the previous main user. Then, log in with your own user account and set yourself as the main user of the vehicle.

If you register a new user and select yourself as the main user during registration, the previous main user is automatically overwritten.

I The type of user and vehicle information to be sent can be influenced by setting the protection level of personal data.

Functionality

Applies to Infotainment Bolero, Amundsen and Columbus.

User accounts

User Management displays the accounts of the last active users. The following activities can be carried out in user management:

- ▶ Select a user account
- ▶ Register user
- ▶ Active ŠKODA Connect services
- ▶ Add and remove user accounts
- ▶ Set the main users
- ▶ Set account security

Overview

Applies to Infotainment Bolero, Amundsen and Columbus.

Main user

The main user provides a registered user with activated ŠKODA Connect services and a vehicle associated with his account.

The main user can take full advantage of the personalisation features.

The main user has full control over the settings and operation of the vehicle.

All settings are saved in the main user's personal online account.

User with a ŠKODA Connect online account

The user was not selected by the main user, but has his own ŠKODA Connect online account.

The user can take full advantage of the personalisation features.

All settings are saved in the registered user's personal online account.

Guest

A guest account is anonymous and will in no way synchronise with ŠKODA Connect services.

All changes to settings related to this account are stored exclusively in the vehicle.

Requirements

Applies to Infotainment Bolero, Amundsen and Columbus.

The following conditions must be met for unlimited use of the management of user accounts and their synchronization with online accounts:

- ✓ A main user with active ŠKODA Connect services is registered in Infotainment.
- ✓ The ŠKODA Connect services are available.

Operation

Applies to Infotainment Bolero, Amundsen and Columbus.

Log in user

After switching on the ignition and Infotainment are switched on, the introductory login screen for the last user account used is displayed.

[i] The introductory log on screen cannot be skipped. Without registering, the Infotainment cannot be used.

- › Confirm the log-in.

When you log in to a secure user account, enter the S-PIN and confirm the login.

Or:

- › Select the menu item for switching user.
A menu containing available users is displayed.
- › Select the desired account.
- › When you log in to a secure user account, enter the S-PIN and confirm the login.

Or:

- › Select the menu item for switching user.
A menu containing available users is displayed.
- › If you are a new user tap *New user* to register the user.
- › Follow the instructions in the Infotainment screen.

Log in to the protected user account

Some user accounts can be protected. Protected accounts are shown in the user list with the icon **u**.

To **log in** to the protected user account you need the S-PIN created when creating the user account on the ŠKODA Connect Portal website, in the ŠKODA Connect application or when registering the user in Infotainment.

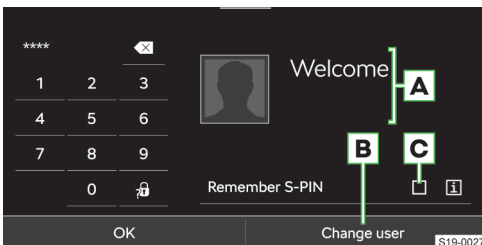

- A** User name
- B** Turn off logging in to the account using the S-PIN
- C** Display of user account management
 - [i]** Display information about the S-PIN
 - u** Display information about restoring the S-PIN
- [i]** User verification by entering the S-PIN can be switched on/off in the menu item **MENU** > **u** > **[i]** > *Protect user profile* > *Protect user profile with S-PIN* will be switched on/off.

Restore S-PIN

Your S-PIN can be restored on the ŠKODA Connect Portal website or in the ŠKODA Connect application.

- › After restoring the S-PIN, register again for the correct functioning of the ŠKODA Connect application in the vehicle as the main user.
- › If you are the main user in several vehicles, register again in each vehicle.

Log out user

When the ignition is switched off, the logout screen is displayed, in which the selected vehicle functions can be viewed.

When the time interval expires, the logout screen is switched of and the user is automatically logged off.

Settings

Applies to Infotainment Bolero, Amundsen and Columbus.

User management

- › Tap **MENU** > **u**.

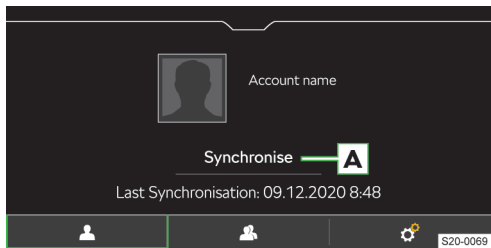

- u** Details of the currently selected user
 - › **u** - A user account protected by the S-PIN
- u** Switch to another user / enter a new user
- [i]** Settings

- A** Online synchronization of the user account with information about the last synchronization

Tap Become main user

- › **MENU** > **u** > **[i]** > *Tap Become main user* and follow the instructions on the screen.

Delete user

- › To display the user accounts, tap **MENU** > 👤 > ⚙️ > Delete users .
- › To delete the user, select the user and confirm the deletion.

I Deleting the main user account will delete the shared user accounts.

Delete the current user account

- › **MENU** > 👤 > ⚙️ > Tap Delete user profile .
- › Confirm the deletion.

Delete all users

Resetting the Infotainment to the factory settings will delete all user accounts.

- › Turn on the ignition and switch on Infotainment.
- › Tap **MENU** > ⚙️ .
- › Restore factory settings select and confirm the reset.

I To check the factory reset was successful, we recommend that you check the deletion of the user accounts and the main user account.

User account**What you should be mindful of**

Applies to Infotainment Swing.

When buying an older vehicle with ŠKODA Connect services, it is possible that the services are active and the main user is the previous owner of the vehicle. The previous owner may also be able to control the vehicle functions and receive information about the user and the vehicle.

Therefore, we recommend removing the previous main user. Then log in with your own user account.

When you register a new user, the previous user is automatically overwritten.

Conditions

Applies to Infotainment Swing.

For user account management, the availability of the ŠKODA Connect services is indispensable.

Settings

Applies to Infotainment Swing.

Delete user

- › Turn on the ignition and switch on Infotainment.
- › Select the following menu:

MENU > ⚙️ > ŠKODA Connect (Online Services) > Registration.

- › Delete owner > Delete .
- › Confirm the deletion.

I By deleting the registered vehicle in the user account on the website ŠKODA Connect Portal the user is also deleted in Infotainment.

Changing the user

- › Turn on the ignition and switch on Infotainment.
- › Select the following menu:

MENU > ⚙️ > ŠKODA Connect (Online Services) > Registration.

- › New owner > Change of owner .
- › Enter and confirm the registration PIN code received during registration of the new user and during vehicle registration on the ŠKODA Connect Portal website.
- › If necessary, confirm the change by confirming Change main user confirm.

Personalisation**Usage**

Applies to Infotainment Bolero, Amundsen and Columbus.

The personalisation service allows you to set, set and store vehicle settings.

The personalisation service is connected to the user accounts. Any change to the set personalised functions is automatically stored in the active user account.

If the vehicle is within range of a contractual mobile phone network, personalisable settings are stored in the ŠKODA ID online user account after the ignition is switched off.

By registering for a user account in another ŠKODA brand vehicle, the custom functions associated with the user account are set according to vehicle type, equipment and infotainment.

Settings

Applies to Infotainment Bolero, Amundsen and Columbus.

Switch personalisation service on / off

- › **MENU** > 👤 > ⚙️ > Privacy settings and manage services .
- › In the displayed list of online services, select the service **personalisation**.
- › Switch the service off / on.

Management of online services**Usage**

The following activities can be carried out in service management:

- ▶ Set protection of personal data
- ▶ Show the list of available services
- ▶ Receive information about the status of the services
- ▶ Receive information about the validity of the services
- ▶ Switch the use of the services on/off

Connection status of the online services

The connection status of the online services of ŠKODA Connect online services is indicated by an icon in the status bar on the Infotainment screen.

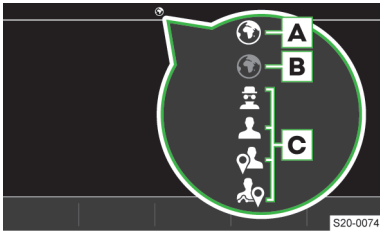

- A** The ŠKODA Connect online services are available.
- B** The ŠKODA Connect online services are not available.
- C** The set personal data protection level

- Maximum privacy
- No position data
- Use my position
- Share my position

Conditions

Applies to Infotainment Swing.

- ✓ A user with active ŠKODA Connect services is registered in Infotainment.
- ✓ The ŠKODA Connect services are available.

Applies to Infotainment Bolero, Amundsen and Columbus.

- ✓ A main user with active ŠKODA Connect services is registered in Infotainment.
- ✓ The ŠKODA Connect services are available.

Operation

Show the list of online services

Applies to Infotainment Swing.

- ▶ **MENU** > > ŠKODA Connect (Online Services) > Privacy and services .

Show the list of online services

Applies to Infotainment Bolero, Amundsen and Columbus.

- ▶ **MENU** > > > Privacy and service management .

Show details of services

- ▶ Select the desired service from the list of online services.

Details about the service may contain the following information and functions:

- ▶ Status of the service
- ▶ Reason for the unavailability of the service
- ▶ Expiry date of the service's validity
- ▶ Switch use of the service on/off

Settings

Switch use of the service on/off

Applies to Infotainment Swing.

- ▶ **MENU** > > ŠKODA Connect (Online Services) > Privacy and services .
- ▶ Select the desired service from the displayed list of online services.
- ▶ Activate / deactivate the desired service.

The service can only be used if it is available.

Switch use of the service on/off

Applies to Infotainment Bolero, Amundsen and Columbus.

- ▶ **MENU** > > > Privacy and service management .
- ▶ Select the desired service from the displayed list of online services.
- ▶ Activate / deactivate the desired service.

The use of the service applies to all user accounts. The service can only be used if it is available.

eSIM data connection

Usage

Applies to Infotainment Bolero, Amundsen and Columbus.

For ŠKODA Connect services, the prepaid e-SIM data connection for online services can be used.

The data connection can be shared with another 8 connected devices using Wi-Fi.

Further information on the function of the data connection, user registration, availability of the data connection and on the overview of the data plans and countries, with the possibility of obtaining them, can be found on the following website:

<https://skoda.cubictelecom.com>



Operation

Applies to Infotainment Bolero, Amundsen and Columbus.

Show ŠKODA Connect data packets

› MENU › ⌂ › Data connection › Data packets .

The following information is displayed in the overview:

- ▶ Overview of the plans purchased
- ▶ Use of the data plans
- ▶ The plan is valid

The validity of the plan expires when the plan is fully used or when the period of validity expires.

Settings

Applies to Infotainment Bolero, Amundsen and Columbus.

Switch the use of the ŠKODA Connect services on/off.

› MENU › ⌂ › Data connection › Integrated data connection (eSIM) .

Online System Update

Usage

The online update enables software updates for the connectivity control unit (OCU) and supported Infotainment type.

The Infotainment automatically indicates a possible online update by showing a message on the Infotainment screen. Infotainment also offers the option of downloading the update or postponing the download process.

Further information on online updates, their availability in the respective countries, on supported vehicles and Infotainment systems can be found on the following website:

<http://go.skoda.eu/online-system-update>



I If the download of the update is postponed, the option to download the update will be offered again the next time the ignition and Infotainment are switched on.

Operation

Download update

- › Turn on the ignition and switch on Infotainment.
- › Follow the instructions and information displayed on the Infotainment screen.
- › Confirm the download in the Infotainment.

The download process can be cancelled at any time. When the ignition is switched on again, the download process is automatically restored.

The download time depends on the speed and quality of the mobile network, the file size, and the type of update.

Install the update

⚠ WARNING

The connectivity control unit (OCU) or Infotainment may not function during installation.

In this event, there are no emergency calls, no automatic emergency calls in the event of an accident and none of the ŠKODA Connectservices will be available.

- ▶ Install the update while the vehicle is stationary.

- › Park the vehicle safely.
- › Switch off the ignition.
- › Confirm the software installation on the Infotainment screen.

The vehicle can be left while the installation continues.

- › Switch on the ignition and Infotainment after installation or return to the vehicle.
- › Check the message regarding successful installation on the Infotainment screen.

I The emergency call indicator light does not light up during installation.

I After a successful installation, the emergency call indicator lamp lights up green.

Requirements

The following conditions must be met for a successful update:

- ✓ The ignition and the Infotainment are switched on.
- ✓ The ŠKODA Connect services were activated in the vehicle.
- ✓ The ŠKODA Connect services are available.
- ✓ The vehicle has an internet connection.
- ✓ The *Maximum privacy* is not set in the vehicle.
- ✓ The online update is available in the relevant country.
- ✓ The charge state of the 12-volt vehicle battery is sufficient.

Self-help

If any of the following events occur while downloading the update or during installation, please contact a service provider:

- ▶ A message appears in the Infotainment screen regarding an incorrect download or installation of the update.
- ▶ The Infotainment screen goes out after switching on.
- ▶ The emergency call indicator lamp lights up red.

Shop

Usage

Applies to Infotainment Bolero, Amundsen and Columbus.

In Infotainment in the Shop menu, the following activities can be carried out

- ▶ Order new functions and services
- ▶ Extend purchased functions and services
- ▶ Buy subsequent ŠKODA Connect data plans

Devices connected via Wi-Fi can also access the data plans.

Further information on the data plans can be found on the following website:

 <https://skoda.cubiclecom.com>



The functions and services can be subject to a runtime limitation or even be unlimited.

The functions and services that are purchased are available to all vehicle users.

The functions and services can also be purchased later on the website ŠKODA Connect Portal.

Overview

Applies to Infotainment Bolero, Amundsen and Columbus.

- › Tap **MENU** › ☰.
- › Select the desired function or service from the list that is displayed.

Requirements

Applies to Infotainment Bolero, Amundsen and Columbus.

The availability of the services and functions depends on the vehicle and Infotainment type as well as being country-specific.

The following conditions must be met to activate new services and functions:

- ✓ Infotainment supports the activation of new services and functions.
- ✓ The vehicle trim level enables the use of new services or functions.

If a service or a function is linked to a trim level that is not available with the vehicle, find out from a specialist garage whether the vehicle trim can be added.

- ✓ The main vehicle user is logged on.
- ✓ The ŠKODA Connect services are active.
- ✓ The ŠKODA Connect services are available.
- ✓ The charge state of the 12-volt vehicle battery is sufficient.

An active data connection is required for certain services or functions. The connection may be chargeable.

Activated services and functions are not linked to the validity period of ŠKODA Connect services.

Limitation

Applies to Infotainment Bolero, Amundsen and Columbus.

The functions are linked to the vehicle, not to the main user account. These cannot be transferred to any other vehicle in which the user logs on.

Information call

Usage

The info call can be used if there are problems with the ŠKODA Connect services or for information regarding the products and services of the ŠKODA brand.

Requirements

- ✓ The ŠKODA Connect services are active.
- ✓ The level of protection of personal data is not set to  *Maximum privacy*.

To send information about the position of the vehicle, the protection level of personal data must be set to  *Share my position*.

Operation

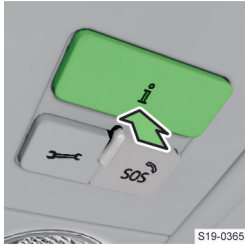

› Press the **i** button.

Version 1

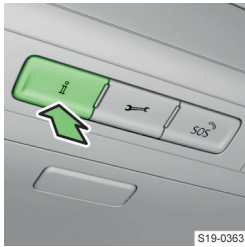

› Press the **i** button.

Version 2

Operation



› Press the **🔧** button.

Version 1

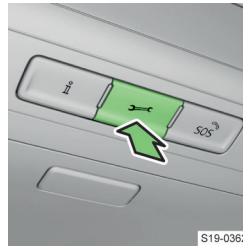

› Press the **🔧** button.

Version 2

Breakdown call

Usage

The breakdown call can be used in the event of a breakdown.

By pressing the key **🔧** a connection is established with the ŠKODABreakdown Service. At the same time, the vehicle sends information about the vehicle condition and the vehicle position.

Requirements

- ✓ The ŠKODA Connect services are active.
- ✓ The level of protection of personal data is not set to **👤 Maximum privacy**.

To send information about the position of the vehicle, the protection level of personal data must be set to **📍 Share my position**.

Service schedules

Usage

If the vehicle detects that a service visit is necessary, it will automatically send this information to the service partner of your choice.

The service partner will then contact you and schedule the service visit with you.

Requirements

The service and the coupled functions are available depending on the following conditions:

- ✓ The service partner is chosen on the ŠKODA Connect Portal website or in the ŠKODA Connect application.
- ✓ The vehicle type, vehicle equipment and Infotainment type are supported.
- ✓ The level of protection of personal data is not set to **👤 Maximum privacy**.
- ✓ The ŠKODA Connect services are active.
- ✓ The ŠKODA Connect services are available.

Vehicle status report

Usage

The vehicle health report function enables the vehicle status to be tracked online.

The service is in the ŠKODA Connect application is available.

The available vehicle data includes, for example, the distance travelled, selected warning messages or service inspection requirements.

Requirements

The service and the coupled functions are available depending on the following conditions:

- ✓ The ŠKODA Connect services are active.
- ✓ The set protection level for personal data that enables the required data to be sent.
- ✓ The ŠKODA Connect services are available.

Remote access to the vehicle

Usage

The service relating to remote access to the vehicle offers the possibility of remotely controlling certain vehicle functions and accessing vehicle information.

Available functions include, for example, the following:

- ▶ Trip overviews
- ▶ Notification of the alarm triggering
- ▶ Localisation service notifications (e.g. location, area or speed notifications)
- ▶ Vehicle search, using horn and flashing signals
- ▶ Remote-controlled vehicle locking and unlocking
- ▶ Operation of the auxiliary heating

Requirements

The service and the coupled functions are available depending on the following conditions:

- ✓ The vehicle type, vehicle equipment and Infotainment type are supported.
- ✓ The set protection level for personal data that enables the required data to be sent.
- ✓ The ŠKODA Connect services are active.
- ✓ The ŠKODA Connect services are available.

Starting and driving

Starting with the key

Notes on starting

⚠ DANGER

Danger of poisoning by exhaust gases!

- ▶ Do not run the engine in an enclosed space.

Positions of the key in the ignition lock

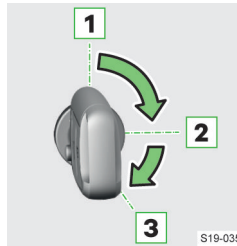

- 1 Ignition off
- 2 Ignition on
- 3 Start the engine

Starting the vehicle with manual transmission

- › Secure the vehicle with the parking brake.
- › Move the shift lever to the neutral position.
- › Keep the clutch pedal depressed.
- › Turn key to position **3**.
- › Release the key.

Starting the vehicle with automatic transmission

- › Secure the vehicle with the parking brake.
- › Keep the brake pedal depressed.
- › Move the selector lever to position **P** or **N**.
- › Turn key to position **3**.
- › Release the key.

1 In vehicles with diesel engines, the warning light lights up after the ignition is switched - glow plug system on. The engine starts after .

⚠ CAUTION

Danger of unexpected vehicle movement!

- ▶ At temperatures below -10°C, start the vehicle with the selector lever in the **P** position.

Stopping the engine

- › Secure the vehicle with the parking brake.
- › Turn key to position **1**.

For vehicles with automatic transmission, the key can only be removed if the selector lever is in position **P** (this only applies to a few countries).

⚠ WARNING

Steering lock hazard!

- ▶ During a journey with the engine stopped, the ignition must always be switched on.

① NOTICE

Risk of engine overheating!

- ▶ Do not switch the engine off immediately at the end of your journey after the engine has been running at high loads. Leave it to run at an idling speed for about 1 minute.

Start at the push of a button

Notes on starting

⚠ DANGER

Danger of poisoning by exhaust gases!

- ▶ Do not run the engine in an enclosed space.

Operating conditions

- ✓ The vehicle key is located in the vehicle interior.

① NOTICE

Risk of key loss, possibly of key damage!

The system can detect the key even if it has been forgotten on the vehicle roof.

- ▶ Always keep the key with you.

Switching the ignition on and off



- ▶ Press the starter button.

Starting the vehicle with manual transmission

- ▶ Secure the vehicle with the parking brake.
- ▶ Move the shift lever to the neutral position.
- ▶ Keep the clutch pedal depressed.
- ▶ Press the starter button.

Starting the vehicle with automatic transmission

- ▶ Secure the vehicle with the parking brake.
- ▶ Keep the brake pedal depressed.
- ▶ Move the selector lever to position **P** or **N**.
- ▶ Press the starter button.

I In vehicles with diesel engines, the warning light lights up after the ignition is switched  - glow plug system on. The engine starts after .

⚠ CAUTION

Danger of unexpected vehicle movement!

- ▶ At temperatures below -10°C , start the vehicle with the selector lever in the **P** position.

Stopping the engine

- ▶ Secure the vehicle with the parking brake.
- ▶ Press the starter button.

⚠ WARNING

Steering lock hazard!

- ▶ During a journey with the engine stopped, the ignition must always be switched on.

① NOTICE

Risk of engine overheating!

- ▶ Do not switch the engine off immediately at the end of your journey after the engine has been running at high loads. Leave it to run at an idling speed for about 1 minute.

Starting issues

Troubleshooting

① NOTICE

Danger of engine damage!

- ▶ Do not start the vehicle by towing.

The engine does not start

- ▶ Switch off the ignition.
- ▶ Wait 30 seconds and repeat the starting procedure.
- ▶ If the engine does not start, use the jump start cables with the 12 volt vehicle battery of another vehicle » page 207 or seek the help of a specialist garage.

The engine does not start, the display shows a message regarding the immobilizer

- ▶ Use the other vehicle key.
- ▶ If the engine does not start, seek the help of a specialist garage.

The key cannot be turned in the ignition

- ▶ Move the steering wheel back and forth while turning the key.

Starting is not possible with the starter button, the system did not detect the key

 illuminates

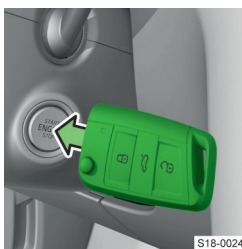

- ▶ Press the starter button with the key.
- ▶ If the engine does not start, seek the help of a specialist garage.

I The key might not be detected if the battery in the key is nearly discharged or the signal is faulty.

The engine cannot be turned off with the starter button

- ▶ Hold the starter button or press twice.

The radiator fan keeps running even after the engine has stopped

The radiator fan can continue to run for approximately 10 minutes after the engine is stopped. This is not a defect.

The engine makes noises after the cold start

The increased running noise is due to the briefly increased engine speed. This is not a defect.

START STOP**Usage**

The START-STOP system reduces polluting emissions and the CO₂ emissions and saves fuel.

Functionality

If the system determines that the engine is not needed when the vehicle stops, it turns off the engine and starts it again when moving off.

Vehicle with manual transmission

A system-related engine switch-off occurs when stopping, when switching the gear lever into the neutral position, and when releasing the clutch pedal.

A system-related engine start occurs when the clutch pedal is pressed down.

Vehicle with automatic transmission

A system-related engine switch-off occurs when the brake pedal is actuated and the engine is stopped.

A system-related engine start occurs when the accelerator pedal is pressed down. When the Auto Hold function is deactivated, a system-related engine start occurs after releasing the brake pedal.

Status display in the instrument cluster display

- Engine is switched off via the START-STOP system



- Engine is not switched off via the START-STOP system due to operating conditions that are not met

Display of detailed information in the infotainment screen

CAR › › Vehicle status

Or:

MENU › › › Vehicle status

Operating conditions

Some conditions are systemic and can neither be influenced nor recognised. Therefore, the system may react differently in situations which seem identical from the driver's perspective.

The driver must fulfil the following conditions.

- ✓ The driver's door is closed.
- ✓ The driver has fastened the seat belt.
- ✓ The driving speed was higher than 4 km/h after the last stop.

Settings**Automatic activation**

- ▶ Upon start-up of the engine.
- ▶ By selecting the driving mode Eco » page 173, *Operation*.

Deactivate/activate system

- ▶ Press the button.

When the system is deactivated, the symbol illuminates in the button .

If a system-related engine switch-off occurs and the system is deactivated, the engine will start.

Troubleshooting**The engine does not switch off when stopping, or it starts before starting up**

The system has detected that the engine is running.

Manual gearbox**Operation****ⓘ NOTICE**

Danger of engine damage!

- ▶ Shift into higher gear before reaching the red area of the rev counter scale.

ⓘ NOTICE

Danger of gearbox damage!

- ▶ Depress the clutch pedal all the way down.
- ▶ If not in the process of changing gear, do not leave your hand on the gearshift lever.

Engaging reverse gear

- ▶ Stop the vehicle.
- ▶ Depress the clutch pedal completely.
- ▶ Move the shift lever to the neutral position.
- ▶ Push the gearshift lever down.
- ▶ Set this completely to the left.
- ▶ Wait briefly.
- ▶ Engage reverse gear.

Automatic gearbox

Lever positions

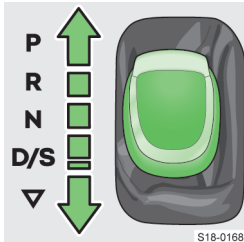

S18-0168

P Parked vehicle

The drive wheels are locked.

P Only set the position when the vehicle is stationary.

R Reverse gear

R Only set the position when the vehicle is stationary.

N Neutral

There is no transmission of engine power to the wheels.

D/S Forward drive / sports program

The gear is changed automatically.

In **S** mode, the gear is changed at higher speeds than in **D** mode.

▽ Choose between D and S (spring-loaded position)

Moving the selector lever out of the P or N position

 lights up - the selector lever is locked



S19-0209

- › Press the brake pedal, and at the same time, press the button in the selector lever.

⚠ WARNING

Risk of the stationary vehicle rolling away automatically!

- ▶ When the selector lever is in the **D/S** position, **R** position or in manual shift mode, secure the vehicle with the brake.

Operation

Starting up

- › Keep the brake pedal depressed.
- › Start the engine.
- › Press the button in the selector lever and set it to the desired position.
- › Release the brake pedal and press the accelerator pedal lightly.

Speeding up while driving (kick-down)

- › Fully depress the accelerator.

Stopping temporarily (e.g. at a junction)

- › Leave the selector lever in the **D/S** position and secure the vehicle with the brake pedal.

Stopping

- › Keep the brake pedal depressed.
- › Secure the vehicle with the parking brake.
- › Press the button in the selector lever and set it to the **P** position.
- › Turn off the engine.

Driving in neutral

If the system detects that no gear is engaged while driving, it automatically switches to neutral position.

 will be displayed in the instrument cluster.

Requirements for driving in neutral position

- ✓ **D** mode is chosen.
- ✓ Neither the accelerator nor the brake pedal is pressed.
- ✓ The vehicle speed is 20-130 km/h.
- ✓ There is no device connected to the trailer socket.

Acceleration on start-up (launch control)

This function allows maximum acceleration during start-up.

- › Select **S** mode or manual shift mode.
- › Disable the TCS » page 179.
- › Keep the brake pedal depressed.
- › Fully depress the accelerator.
- › Release the brake pedal.



The vehicle drives with maximum acceleration.

Manually switching gear with the selector lever

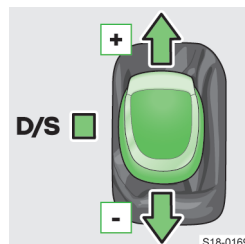
- › To **turn on**, put the selector lever in the **D/S** position to the right (to the left for right-hand drive vehicles).
- › To **turn off**, put the selector lever back in the **D/S** position.



S18-0169

-  Changing up a gear
-  Changing down a gear

Manually changing gear with the shift paddles on the steering wheel

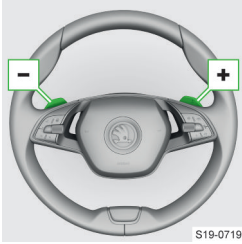

- Changing down a gear
- + Changing up a gear
- › To **switch on** the shift paddle, press **-** or **+**.
- › To **turn off** the shift paddle, hold **+**.

S19-0719

If none of the shift paddles are pressed for a certain time, manual shift mode turns off automatically.

If the engine threatens to over-rev



- ▶ The gearbox automatically changes to the next higher gear.
- ▶ The transmission prevents changing to the next lower gear.

Troubleshooting



The selector lever cannot be moved out of position P in the normal way



- › Manually unlock the selector lever » page 172.

Gearbox overheated



-  illuminates together with 

or



-  illuminates together with  Message regarding the gearbox overheating
- › You may continue driving, exercising appropriate caution.

-  illuminates together with 



or

-  illuminates together with  Message regarding the gearbox overheating
- › Stop driving! Stop the vehicle and stop the engine.
- › After the indicator light goes out, your journey can continue.
- › If the warning light does not go out, stop driving! Seek the help of a specialist garage.



Gearbox impaired

-  illuminates together with 



or

-  illuminates together with  Message regarding the gearbox in emergency mode

- › You may continue driving, exercising appropriate caution.
- › Immediately seek the help of a specialist garage.

-  illuminates together with 

or

-  illuminates together with  Message regarding a gearbox fault
- › Stop driving! Seek the help of a specialist garage.

Starting up a vehicle that is stuck

- › Adjust the selector lever between **D/S** and **R**. The vehicle will then start to rock and be easier to free.

Manual release of automatic gearbox

- › Secure the vehicle with the parking brake.
- › Open the stowage compartment in the front centre console.

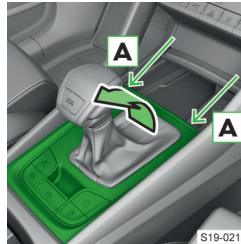

- › Insert a flat-head screwdriver or push a similar tool into the gap in the area of arrow **A**.
- › Carefully loosen and lift the quadrant cover.

S19-0219

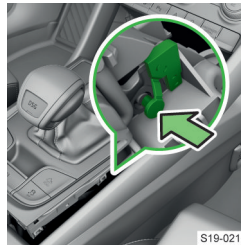

- › Press on the plastic part in the direction of the arrow and at the same time press the button on the selector lever.
- › Put the selector lever in **N** position.

S19-0210

Vehicle driving mode

Usage

The driving mode offers the possibility of adapting the driving behaviour to the desired driving style.

Overview

Information about the selected driving mode is displayed in the status bar in the Infotainment screen as well as in the digital instrument cluster.

Eco mode

Eco mode is suitable for a relaxed style of driving and helps to save fuel.

Comfort mode

Comfort mode is suitable for driving on roads with poorer surface or for long motorway journeys.

Normal mode

The Normal mode is suitable for a conventional driving.

Sport mode

The Sport mode is suitable for a sporty driving.

Individual mode

The Individual mode allows the individual configuration of certain vehicle systems.

Snow mode



Snow mode is suitable for driving on slippery or snowy roads. In this mode, the automatic gearbox cannot be set to mode S.

Offroad mode

Offroad mode is suitable for driving on non-paved roads. But even with Offroad mode switched on, your vehicle is never a true SUV.

The following brake and stabilisation systems change in Offroad mode.

- ▶ ESC.
- ▶ ASR.
- ▶ EDL.
- ▶ ABS.

When switched on Offroad mode lights up  ,  and  in the instrument cluster.

Operation

Select driving mode

- › Press the  button.

In the Infotainment, a driving mode menu appears.

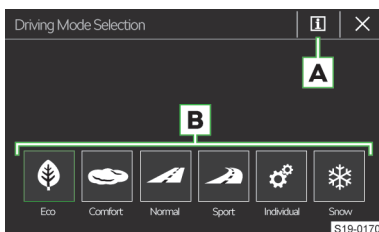

A Information on the system settings of the currently selected mode/system settings for the selected Individual mode

B Driving mode menu

- › Tap the relevant function surface **B**.

Or:

- › Press the  button again.

I After switching on the ignition, Normal mode is automatically selected.

Switch on Offroad mode

- › Press the  button.

The Offroad information appears in the Infotainment.



Offroad information

The Offroad information serves to determine the current driving situation.

The Offroad information display is shown in the Infotainment in the menu item:

CAR >  > Offroad

Or:



MENU >  >  > Offroad

A swipe of the finger vertically across the screen allows three of the following displays to be shown.



- ▶ Steering angle
- ▶ Coolant temperature
- ▶ Oil temperature
- ▶ Compass (Infotainment Amundsen, Columbus)
- ▶ Altimeter (Infotainment Amundsen, Columbus)

Troubleshooting

Adaptive DCC suspension faulty

 illuminates together with 

or

 illuminates together with 

- › Drive on, exercising appropriate caution. Seek the help of a specialist garage.

Economical driving style

Tips for economical driving and evaluation of driving economy

Tips for economical driving

- ▶ Avoid unnecessary acceleration and braking.

- ▶ Follow the gear recommendation in the display of the instrument cluster.
- ▶ Avoid full acceleration and too high speeds.
- ▶ Avoid engine idling during longer periods of stationary time.
- ▶ Do not warm up the engine while the vehicle is stationary. If possible, start your journey as soon as the engine starts.
- ▶ Observe the prescribed tyre pressure » page 215.
- ▶ Remove unnecessary ballast.
- ▶ Remove the roof rack when it is not needed.
- ▶ Switch on electric consumers only for as long as necessary.
- ▶ Do not leave the windows open while driving.

Display of evaluation in the infotainment screen

CAR > > DriveGreen

Or:

MENU > > > DriveGreen

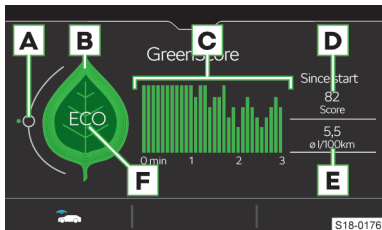

- A Display of steady driving**
When driving steadily, the display is located near the green dot.
- B Leaf**
The greener the leaf, the more economic the driving style. Tapping the screen near the leaf displays tips for reducing fuel consumption and energy consumption.
- C Driving efficiency chart**
Each bar indicates driving efficiency in 5 second increments. The current bar is on the left. The higher the green bars, the more economical the driving style.
- D Point value (0-100)**
The higher the indicated value, the more economical the driving style. Tapping the screen near the value **D** displays a rating for the last 30 minutes of driving.
- E Average fuel consumption**
Tapping the screen near the value **E** displays the average fuel consumption during the last 30 minutes of driving.
- F Information about the current driving**
 - ▶ **ECO** Economical driving style

- ▶ The speed has a negative effect on fuel consumption
- ▶ The ride is not steady
- ▶ 4 Recommended gear

I In Infotainment it is possible to display up to three consumers that are currently making up the largest share of fuel consumption.

CAR > > Convenience consumers

Or:

MENU > > > Convenience consumers

Consumption-friendly driving

In the following situations, a small reduction in fuel consumption occurs. lights up in the instrument cluster.

- ▶ Active cylinder management has temporarily disabled some cylinders in the engine (applies to certain engine types).
- ▶ A vehicle with automatic transmission rolls in neutral position.

Towing a trailer

What you should be mindful of

⚠ WARNING

When driving with a trailer, special care is required!

① NOTICE

With frequent towing, the vehicle is excessively loaded so this must also be checked between service intervals.

Recommendations for using a trailer

- ▶ Adjust the tyre pressure on the vehicle for full load.
- ▶ Do not exceed the maximum permissible total weight of the vehicle and the combination weight specified in the technical vehicle documentation (e.g. in the vehicle registration documentation, in the COC document) and on the type plate.
- ▶ For trailer operation, consider the current load condition of the vehicle as well as the distribution of the load in the trailer. The coupled trailer increases the rear axle load and can therefore reduce the payload.
- ▶ Adjust the headlight range of the headlights according to the load status of the vehicle. The front of the vehicle may lift up when a trailer is being towed and the headlights may dazzle other road users.
- ▶ A speed of **100 km/h** should not be exceeded.
- ▶ Reduce the speed by releasing the accelerator pedal as soon as a pendulum movement of the trailer is noticeable. Never attempt to stop the trailer from swaying by accelerating.
- ▶ If the traffic area behind the trailer can not be viewed, install additional exterior mirrors.

- ▶ Apply the brakes in good time. If the trailer is fitted with a trailer brake, apply the brakes gently at first, then brake firmly. This will avoid brake jolts resulting from the trailer wheels locking.
 - ▶ Select a lower gear before descending to also use the braking force of the engine.
- Distribution of the load over the vehicle and trailer combination**
- ▶ Secure heavy objects against slipping, as close to the trailer axle as possible.
 - ▶ Transport small and light objects in the luggage compartment.

Permitted trailer loads

The details in the technical vehicle documentation take precedence over the information in this Owner's Manual.

⚠ WARNING

Risk of an accident!

- ▶ Do not exceed the permissible trailer load.

Engine type	Gearbox	Permissible trailer load, braked (kg) ^{a)}	Permissible trailer load, unbraked (kg)
1.0 I/81 kW TSI	Manual gearbox	1200	670
1.4 I/110 kW TSI	Automatic gearbox	1500	690
	DSG ^{b)} 4x4	1700	750
1.5 I/110 kW TSI	Manual gearbox	1500	690
	DSG ^{b)}	1500	690
2.0 I/140 kW TSI	Manual gearbox	1500	660
	Automatic gearbox	1500	670
1.6 I/81 kW MPI	Manual gearbox	1500	720
	Automatic gearbox	1500	730
2.0 I/85 kW TDI CR	DSG ^{b)}	1800	720
2.0 I/105 kW TDI CR	DSG ^{b)}	1800	720
2.0 I/110 kW TDI CR	Manual gearbox	1800	720
	DSG ^{b)} 4x4	2100	750

^{a)} With gradients up to 12%.

^{b)} Automatic dual-clutch transmission.

Towing eye and towing procedure

Towing lug

Removing the grille



S19-0283

- ▶ Insert the clamp for taking off the full wheel trims in the recess in the grille, and remove the grille.

Removing the rear cap



S19-0284

- ▶ Press on the cap and remove it.

Installing the towing eye

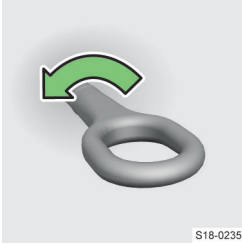

S18-0235

- › Screw in the towing eye.
- › Insert the wheel wrench or similar object through the towing eye.
- › Tighten the towing eye.

After the towing process

- › Unscrew the towing eye.
- › Insert the cover or grille.

Towing the vehicle

⚠ WARNING

Risk of accident!

- ▶ The tow rope must not be twisted.
- ▶ When towing, drive at a speed of max. 50 km/h.

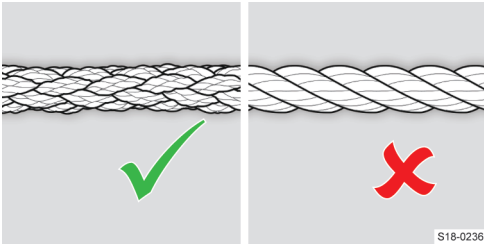

S18-0236

⚠ WARNING

Risk of accident!

- ▶ Use a braided synthetic fibre rope for towing. Do not use a twisted tow rope.

① NOTICE

- ▶ Always keep the tow rope taut during towing.
- ▶ Do not exceed a towing distance of 50 km.

① NOTICE

Danger of gearbox damage!

- ▶ If the gearbox no longer contains any oil, the vehicle must only be towed with the front axle raised clear of the ground or transported on a special breakdown vehicle.
- ▶ Vehicles with automatic transmission must not be towed without the ignition switched on or with the rear axle raised.

Where should the tow rope or the tow bar be secured?

- ▶ At the front towing eye
- ▶ At the rear towing eye
- ▶ On the ball bar of the factory-installed towing hitch

ⓘ For vehicles with factory-fitted towing device, at the back there is no mount for a screw-in towing eye.

Information for the driver of the towing vehicle

- › Drive slowly and smoothly.
- › Only accelerate once the rope is taut.

Information for the driver of the towed vehicle

- › Move the shift lever to the neutral position or the selector lever to the N position.
- › If it is not possible to start the engine, switch on the ignition!

⚠ WARNING

Risk of accident!

When the ignition is switched off, the brake booster and the power steering do not work. In addition, there is a risk that the steering lock will engage.

- ▶ If it is not possible to start the engine, switch on the ignition!

Brakes

What you should be mindful of

⚠ WARNING

Problems and faults with the brake system can extend the braking distance of the vehicle!

⚠ DANGER

Danger of a functional restriction of the brake booster!

- ▶ When braking in a vehicle with manual transmission, when the vehicle is in gear and at low revs, depress the clutch pedal.

⚠ DANGER

Danger of the brakes overheating!

- ▶ Do not depress the brake pedal unless braking is required.
- ▶ If the original front spoiler is damaged, ensure the air supply to the front brakes is guaranteed.

Inspecting the brake fluid level

Test conditions

- ✓ The vehicle is on a horizontal surface
- ✓ The engine is off

Checking



The fill level must be within the marked range.

- › If the level is below the mark **MIN**, do not continue.
- › Do not refill liquid.
- › Seek the help of a specialist garage.

If the brake fluid level is too low, this will be indicated in the instrument cluster by the illumination of  is displayed in the status bar. Nevertheless, we recommend checking the brake fluid level regularly directly at the reservoir.

WARNING

Danger of brake failure!

If the fluid level falls significantly within a short time or drops below the mark **MIN**, the brake system may have become leaky.

- ▶ Stop driving! Seek the help of a specialist garage.

Specification

The brake fluid must comply with standard VW 501 14. This standard complies with the requirements of the FMVSS 116 DOT4 standard.

Changing

Have the brake fluid replaced by a specialist garage.

WARNING

Danger of brake failure!



If the brake fluid change date is exceeded, heavy braking may cause vapour bubbles to form in the brake system.

Troubleshooting

Brake fluid level is too low

-  illuminates
 - › Stop driving! Seek the help of a specialist garage.

Brake system and anti-lock braking system faulty

-  illuminates together with 
 - › Stop driving! Seek the help of a specialist garage.

Worn brake pads

-  illuminates
 - › Drive to a specialist garage, exercising appropriate caution.

Reduced braking effect

Damp, frozen, salt-affected or corroded brakes can impair the braking effect.

- › Clean the brakes by braking several times if traffic conditions allow it.

When the engine is stopped, the brake booster does not work

- › Depress the brake pedal more forcefully.

Electric parking brake

Operation

WARNING

Danger of key locking!

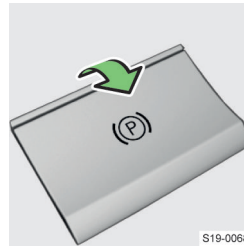

- ▶ The recessed grip for the fingers in front of the button  must remain empty.

Manual switch on



- › Pull the button  and hold it.

The following symbols light up.

- ▶  in the button.
- ▶  in the instrument cluster.

Automatic shut-off

The parking brake switches off automatically when starting up.

If automatic switch-off is to be prevented, e.g. when starting off on a slope, keep the button  pulled.

Conditions for automatic shutting down

- ✓ Driver's door is closed, in some cases, the driver's seat belt is also fastened

Manual shut-down

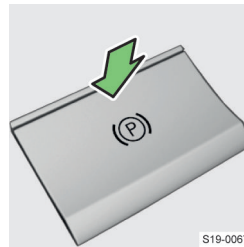

- › With the ignition switched on, press the brake pedal and at the same time push the  button.

Troubleshooting

Parking brake error

-  illuminates

Message regarding a parking brake error

- › Seek the help of a specialist garage.

Parking on a steep slope

(P) flashes

Notification regarding parking position on a steep slope

- › Go to another parking spot where there is less of a slope.

Noise when using the parking brake

Noise when using the parking brake is normal. This is not a defect.

The 12 volt vehicle battery is discharged, the parking brake cannot be switched off

- › Connect the 12 volt vehicle battery to a power source, such as the 12 volt vehicle battery of another vehicle.

With **Start**, the vehicle is automatically **released** using Auto Hold.

Automatic protection from the parking brake

Under certain circumstances, the vehicle can be secured using the parking brake. (P) lights up in the instrument cluster.

Operating conditions

- ✓ The driver's door is closed.
- ✓ The engine is running or has been switched off by the START-STOPP system.
- ✓ Auto Hold is activated.
- ✓ On vehicles with an automatic gearbox, the selector lever is not in **N** mode.

Emergency braking in case of faulty brake system

Switching on

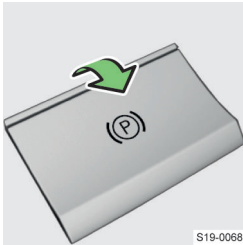

- › Pull the button (P) and hold it.

The vehicle starts to brake **sharply** and an acoustic signal is sounded.

Settings

Activation/deactivation

- › Press the (A) button.

Activation is indicated by the illumination of the symbol (A) in the button.

ⓘ NOTICE

Disable Auto Hold to allow the vehicle to roll if necessary when driving through a car wash.

Switching off

- › Release the button (P).

Or:

- › Depress the accelerator pedal.

Auto Hold automatic holding function

Usage

Auto Hold automatically secures the vehicle from rolling away when stopped.

Functionality

⚠ WARNING

Risk of an accident!

Auto Hold is not able to stop the vehicle under all circumstances, such as on slippery ground, or on gradients.

Secure and release the vehicle

With **Stop**, the vehicle is automatically **secured** using Auto Hold. (P) lights up in the instrument cluster. The brake pedal can be released.

Driver assist systems

Braking and stabilising systems

Overview

Stabilisation control (ESC)

ESC helps to stabilize the vehicle in borderline situations (e.g. when the vehicle starts to skid). ESC brakes the individual wheels to maintain the direction of travel.



flashes - ESC is engaged

ESC Sport

ESC Sport allows for a sportier driving style.



lit up - ESC Sport is activated

Traction control (TCS)

ASR helps to stabilize the vehicle when accelerating or driving on low-grip roads. ASR reduces the drive power transmitted to the wheels when the wheels spin.



flashes - ASR is engaged

Antilock braking system (ABS)

ABS helps maintain control of the vehicle during emergency braking. An ABS intervention is noticeable by pulsating movements of the brake pedal.

Motor Slip Regulation (MSR)

MSR helps to maintain control of the vehicle in the event of a sudden reduction in speed, e.g. on icy roads. If the drive wheels lock, MSR increases the engine speed. This reduces the braking effect of the engine and the wheels can rotate freely again.

Electronic Differential Lock (EDL)

EDL helps to stabilize the vehicle when driving on road surfaces with different grip under the individual wheels. EDL brakes a spinning wheel and transmits power to a different drive wheel.

Electronic Differential Lock (XDL+)

XDL+ helps to stabilize the vehicle during fast cornering by braking the inside wheel of the driven axle.

Active steering assistance (DSR)

In difficult situations, the DSR provides the driver with a steering recommendation in order to stabilise the vehicle.

Hill Hold Control

Hill Hold Control helps when starting off on uphill gradients by braking the vehicle for about 2 seconds after the brake pedal is released.

Operating conditions

- ✓ The gradient is at least 5%.
- ✓ The driver's door is closed.

Multi-Collision Brake (MCB)

MCB helps to decelerate and stabilize the vehicle after a collision with an obstacle. This reduces the risk of further collisions.

Operating conditions

- ✓ There has been a frontal, side and rear collision of a certain severity.
- ✓ The impact speed was greater than 10 km/h.
- ✓ The brakes, ESC and other required systems remained functional after the impact.
- ✓ The accelerator pedal is not pressed.

Trailer Stability Assist (TSA)

TSA helps to stabilize the trailer. As the trailer begins to lurch, TSA stabilizes the trailer by slowing down the individual vehicle wheels.

Operating conditions

- ✓ The hitch was supplied from the factory or purchased from ŠKODA Genuine Accessories.
- ✓ The trailer is connected to the trailer socket.
- ✓ ASR activated.
- ✓ The driving speed is higher than 60 km/h.

Settings

Deactivating/activating ASR

› Press the  button.

Or:

› In Infotainment, select the following menu:

MENU >  >  > 

Or:

CAR >  > 

When deactivated,  lights up in the instrument cluster.

 goes out on renewed activation.

Deactivating the ASR may be helpful in the following situations:

- ▶ Driving with snow chains
- ▶ Driving in deep snow or on very loose ground
- ▶ Starting up a vehicle that is stuck

Activate/deactivate ESC Sport

› Keep the  button pressed down.

Or:

› In Infotainment, select the following menu:

MENU >  >  > 

Or:

CAR >  > 

When activated,  lights up in the instrument cluster.

 goes out when deactivated.

Troubleshooting

ESC or ASR faulty/deactivated by the system

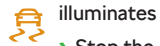

illuminates

- › Stop the engine and start again.
- › If the indicator light does not go out after covering a short distance, seek the help of a specialist garage.

ABS faulty

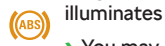

illuminates

- › You may continue driving, exercising appropriate caution. Seek the help of a specialist garage.

Brake system and anti-lock braking system faulty

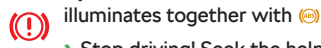

illuminates together with

- › Stop driving! Seek the help of a specialist garage.

Front Assist

Functionality

Front Assist monitors the distance to the vehicle ahead and points out when the safety distance is exceeded. In borderline situations, it helps to avoid a collision by braking interventions.

Status display in the instrument cluster display

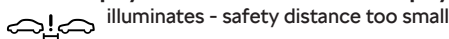

illuminates - safety distance too small

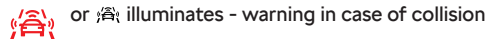

or illuminates - warning in case of collision

Automatic braking if there is a risk of a collision

If there is a risk of a collision, the following symbol is illuminated as a warning: or from the isolation box. If you do not respond to the warning, the vehicle will slow down.

At a driving speed of up to 30 km / h, the vehicle is braked without prior warning.

Automatic braking can be stopped by pressing the accelerator pedal or by a steering intervention.

With automatic braking, the pressure in the brake system increases. The brake pedal cannot be operated by using the pedal as normal.

⚠ WARNING

Risk of an accident!

Front Assist does not respond to crossing or oncoming vehicles.

Operating conditions

- ✓ The parking aid is activated.
- ✓ The driving speed is higher than 5 km/h.

Function restriction

The function may be restricted or unavailable in the following cases:

- ▶ About 30 seconds after starting (lights up in the instrument cluster)
- ▶ When driving around a sharp bend
- ▶ During an ESC intervention

Settings

Automatic activation

Front Assist is automatically activated when the ignition is switched on.

Activation/deactivation in the instrument cluster

- › Press the button on the multifunction steering wheel.
- › Select *Front Assist*.

Activation/deactivation in Infotainment

In the menu **MENU** > > > .

Show system deactivation in the display of the instrument cluster

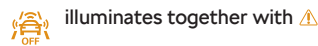

or

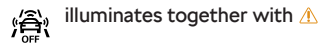

- ▢ Deactivate Front Assist when handling the vehicle on a truck, a car ferry etc.

Troubleshooting

Front Assist is not available

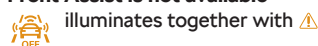

Or:

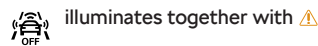

- › Clean the front radar sensor.
- › Stop the engine and start again.
- › If Front Assist is still unavailable, check the brake lights on the vehicle or on the attached trailer.
- › If the brake lights are working and Front Assist is still unavailable, seek the help of a specialist garage.

There was an unfounded warning or system intervention



- › Clean the front radar sensor.
- › If the system is not working properly, disable Front Assist and seek the help of a specialist garage.

Pedestrian detection system

Functionality

Pedestrian recognition helps to prevent a collision with crossing pedestrians by enabling automatic braking interventions.

Status display in the instrument cluster display

 or  lights up - Danger of collision

Risk of collision in a speed range of 5-30 km/h

The system triggers automatic braking.

Risk of collision in a speed range of 30-60 km/h

The system warns of a collision hazard first. If the driver does not respond, the vehicle is automatically braked.

Operating conditions

- ✓ Front Assist is deactivated.
- ✓ The vehicle speed is 5-60 km/h.

Speed limiter

Functionality

The speed limiter controls the maximum driving speed according to the set speed limit.

If the limit is exceeded when driving downhill, brake the vehicle with the brake pedal.

Status display in the instrument cluster display

 illuminates - the cruise control is activated.
flashing - the set limit is exceeded

When the regulation starts  highlighted and the set limit is displayed.

Operating conditions

- ✓ The driving speed is higher than 30 km/h.

Operation

Variant without cruise control

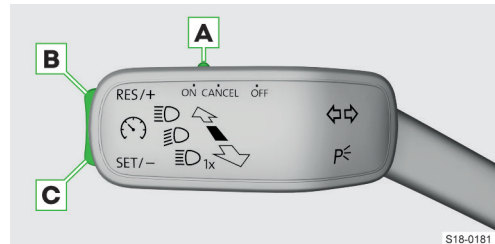

- A** ON Activate limiter (control inactive)
OFF Deactivate limiter
CANCEL Interrupt control (sprung position)
- B** RES/+ Resume control¹⁾ / Increase limit
- C** SET/- Start control with current speed / Reduce limit

Variant with cruise control

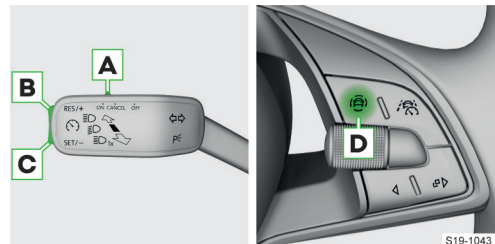

- A** ON Activate cruise control (condition for the subsequent activation of the limiter).
To enable the speed limiter, press the button **D** and in the instrument cluster choose the menu item *Speed limit*.
OFF Deactivate limiter
CANCEL Interrupt control (sprung position)
- B** RES/+ Resume control¹⁾ / Increase limit
- C** SET/- Start control with current speed / Reduce limit
- D** @ Show menu of assist systems - Possibility of switching between cruise control and speed limiter
Switching to cruise control interrupts the control.

Adjusting the speed limit with the buttons **B** and

C

By pressing in steps of 1 km/h.

¹⁾ If no speed limit is set, the current speed is set as the speed limit.

By holding in steps of 10 km/h.

Variant with ACC

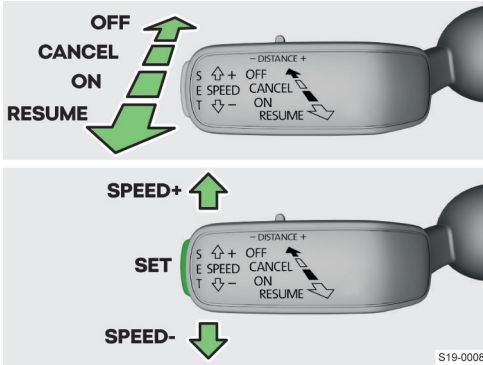

ON Activate ACC (condition for the subsequent activation of the limiter). To enable the speed limiter, press the button and in the multi-function steering wheel and in the instrument cluster choose the menu item *Speed limit*.

RESUME Resume control ¹⁾ / Increase limit in steps of 1 km/h (sprung position)

CANCEL Stop control (sprung position)

OFF Deactivate the limiter

SPEED+ Increase limit in steps of 10 km/h

SPEED- Decrease limit in steps of 10 km/h

SET Start control/Reduce limit in steps of 1 km/h

Limit exceeded

› Fully depress the accelerator.

Control will continue as soon as the vehicle has decelerated to below the set limit.

Troubleshooting

Speed limiter faulty

LIM illuminates

› Seek the help of a specialist garage.

Cruise control system

Functionality

The cruise control system maintains the set speed without the accelerator pedal having to be operated.

This, however, is only possible to the extent permitted by the engine output and braking power of the vehicle.

⚠ WARNING

Risk of the cruise control system starting unintentionally!

▶ Deactivate cruise control after use.

Status display in the instrument cluster display

illuminated - the cruise control system is activated

illuminated - cruise control is active

When cruise control starts, the set speed is displayed.

Operating conditions

✓ The driving speed is higher than 20 km/h.

Operation

Operating with the lever

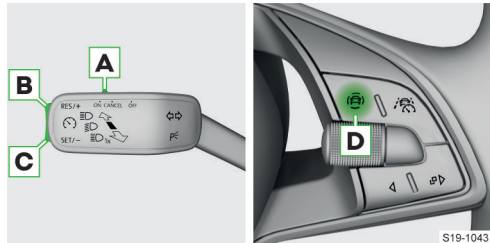

A **ON** Activate cruise control (cruise control deactivated)

OFF Deactivate cruise control

CANCEL Interrupt control (sprung position)

B **RES/+** Resume cruise control²⁾/Increase speed

C **SET/-** Start control with current speed/Reduce limit

D Show menu of assist systems - Possibility of switching between cruise control and speed limiter

Accelerate temporarily

› Depress the accelerator pedal.

Releasing the accelerator pedal will cause the speed to drop again to the set speed.

Interrupting cruise control

▶ After pressing the brake pedal

▶ After an ESC intervention

¹⁾ If no speed limit is set, the current speed is set as the speed limit.

²⁾ If no speed is set, the current speed is adopted.

Troubleshooting

Cruise control system faulty



illuminates

- › Seek the help of a specialist garage.

Adaptive Cruise Control (ACC)

Functionality

ACC control

ACC maintains the set speed. When your vehicle approaches the vehicle in front, ACC will automatically start to maintain the set distance to this vehicle.

Maintaining the set speed and the distance will hereinafter be referred to as **Control**.

⚠ WARNING

ACC does not respond to crossing or oncoming objects.

▢ ACC is intended primarily for use on motorways.

pACC (predictive cruise control)

pACC represents an extension of the ACC system.

pACC adjusts the speed according to recognized speed limits and the route, e.g. curves, intersections or roundabouts.

The system uses the following sources to evaluate the situation:

- ▶ Navigation data
- ▶ Traffic Sign Recognition
- ▶ Sensors, radars and cameras

⚠ WARNING

pACC does not respond to railway crossings.

Speed range

Depending on the equipment, ACC allows a speed setting in the range of 30-160 or 30-210 km/h.

If control is started at a speed of less than 30 km/h on vehicles with an automatic transmission, the speed is automatically increased to 30 km/h or controlled according to the speed of the vehicle ahead.

Distance level

The distance to the vehicle ahead can be adjusted to five different levels.

⚠ WARNING

- ▶ Maintain a minimum distance in accordance with the country-specific legal regulations.

Automatic stop and start with automatic gearbox

A vehicle with an automatic transmission can be decelerated to a stop using the ACC and start moving again. Control is disconnected in case of longer holding periods.

To resume the regulation:

- › Depress the accelerator pedal.

Or:

- › Set the lever in position **RESUME**.

Or:

- › *Applies to vehicles with hand recognition on the steering wheel:* Grab the steering wheel again.

The control is interrupted when the brake pedal is depressed.

Overtaking

If your vehicle changes to the fast lane and no vehicle is detected in front, ACC accelerates up to the set speed.

Status display in the instrument cluster display



illuminates - ACC is activated

Depending on the equipment:



illuminates - Control is active

or



illuminates together with  - Control is active

When the control starts, the set speed is displayed.



illuminates - ACC does not decelerate sufficiently

- › Depress the brake pedal.

Status display in the instrument cluster display



illuminates - ACC is activated



illuminates - Control is active

When the control starts, the set speed is displayed.



illuminates - ACC does not decelerate sufficiently

- › Depress the brake pedal.



illuminates - ACC controls the driving speed according to the permissible speed



illuminates - ACC controls the driving speed according to the approaching roundabout



illuminates - ACC controls the driving speed according to the approaching junction



illuminates - ACC controls the driving speed according to the road

Operation

Operating with the lever

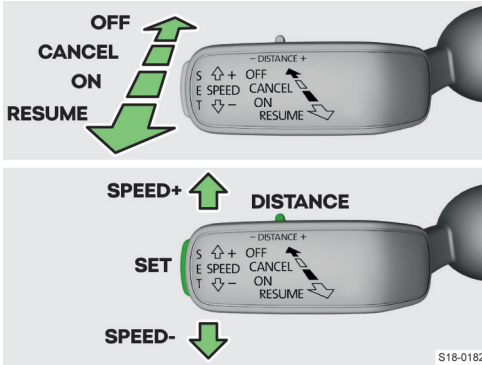

- ON** Activate ACC (control inactive)
- RESUME** Start or resume control/Increase speed in steps of 1 km/h (sprung position)
- CANCEL** Stop control (sprung position)
- OFF** Deactivate ACC
- SPEED+** Increase speed in steps of 10 km/h
- SPEED-** Reduce speed in steps of 10 km/h
- DISTANCE** Set distance level
- SET** Start control/Reduce speed in steps of 1 km/h

Starting control with the current speed

- ▶ Tap on **SET**.

Or:

- ▶ If no speed is saved, move the lever to the sprung position **RESUME**.

Set distance level

- ▶ Move the **DISTANCE** switch to the sprung position - or +.

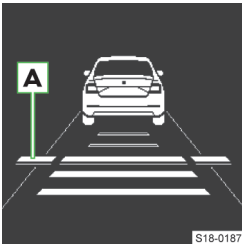

Line **A** appears in the display, indicating the change in distance.

- ▶ Use the **DISTANCE** switch to set the desired distance level.

For temporary acceleration

- ▶ Depress the accelerator pedal.

The vehicle accelerates and control is temporarily interrupted. Upon releasing the accelerator, control is resumed.

Interrupting cruise control

- ▶ After pressing the brake pedal
- ▶ By operating the clutch pedal for a long time
- ▶ After an ESC intervention
- ▶ After deactivation of the ASR

Resuming control

- ▶ If a speed is stored, move the lever to the sprung position **RESUME**.

The vehicle is controlled at the set speed. The set speed is shown in the instrument cluster display.

Function restriction

Do not use the ACC in the following cases:

- ▶ The vehicle is making a sharp turn.
- ▶ The vehicle is travelling on a sloping road or in ruts.
- ▶ When the driving lane is too narrow.
- ▶ The vehicle drives through a construction site.

⚠ WARNING

- ▶ Be particularly attentive and alert in the following situations.

Regulation according to the vehicle in the adjacent lane

If your vehicle is moving faster than the vehicle in the next lane on the driver's side, at a speed of more than 80 km/h, this may cause your vehicle to be controlled according to that vehicle.

When cornering

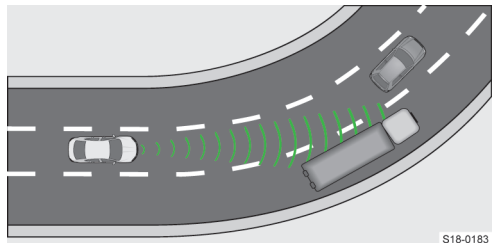

When cornering, a vehicle in the next lane may enter the detected area. Your vehicle will be controlled according to this vehicle.

Narrow or staggered vehicle

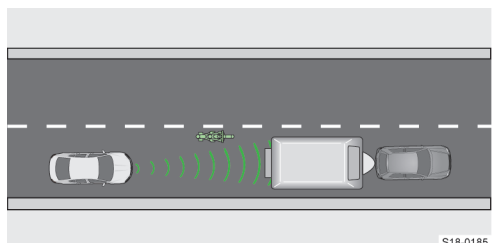

ACC detects a narrow or staggered vehicle only when it is in the area covered by the radar.

Lane change by another vehicle

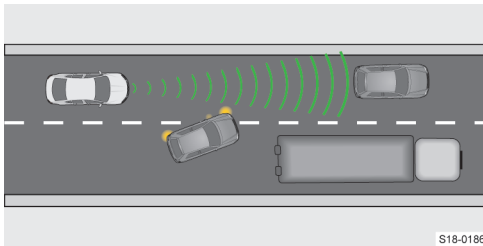

A vehicle that changes to the lane a short distance away may not be recognized by the ACC in time.

Stationary vehicle

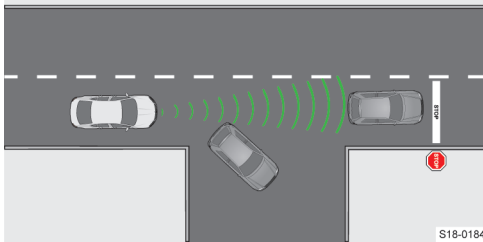

If a vehicle in front turns and there is a stationary vehicle in front of this vehicle, the ACC must not respond to the stationary vehicle.

Vehicles with special load or special bodies

A load or superstructure that protrudes outside the vehicle might not be detected by the ACC.

Settings

Activation / deactivation and setting

In the Infotainment system, in the menu **MENU** › › .



- ▶ **Driving programme:** - Setting the vehicle acceleration when the ACC is switched on (this setting is made for vehicles with driving mode selection » page 173)
- ▶ **Last distance selected** - Switch on/off the last distance selected
- ▶ **Distance:** - Setting the distance to vehicles in front
- ▶ **Road layout preview** - Switch the cruise control on/off according to the road profile (e.g. reduce speed before a bend)
- ▶ **Speed limit preview** - Switch the speed control on/off according to the permissible speed

Troubleshooting

ACC not available

illuminates together with

or

illuminates together with

- › Stop the engine and start again.
- › If ACC is still unavailable, check the brake lights on the vehicle or on the attached trailer.
- › If the brake lights are working and ACC is still unavailable, seek the help of a specialist garage.

Lane Assist

Usage

Lane Assist helps to keep the vehicle within the lane. It is based on the boundaries of a lane. These may include lane markings, road edges or objects such as curbs or possibly traffic cones.

The system is intended primarily for use on highways.

Functionality

As the vehicle approaches a lane marking, the system executes a steering movement in the opposite direction from the lane marking. The steering intervention can be overridden manually.

No system intervention occurs when changing lane with the turn signal on.

Status display in the instrument cluster display

lights up - System is activated and ready to intervene

lights up - System is activated and ready to intervene

lights up - System intervenes

lights up - System intervenes

Display

Display example in black and white display.

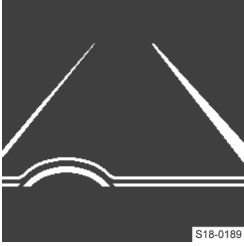

Lane boundary highlighted on the right: system intervenes on the right when approaching the lane marking.

In the coloured display, the lines are highlighted in colour.

Warning through steering wheel vibrations

The steering wheel vibrations are triggered in the following situations:

- ▶ The vehicle crosses the boundary line without the indicator light switched on.
- ▶ The system is not able to keep the vehicle within the lane.
- › Correct the steering movement in the event of vibrations.

Operating conditions

- ✓ The driving speed is higher than 60 km/h.
- ✓ The lane markings are clearly visible.

Function restriction

The system function may be restricted in the following cases:

- ▶ The field of view of the sensor is limited by a dirty screen or an obstacle or a preceding vehicle.
- ▶ If the weather conditions are unfavourable.
- ▶ The vehicle is making a sharp turn.
- ▶ The vehicle is travelling on a sloping road or in ruts.
- ▶ When the driving lane is too narrow.
- ▶ The vehicle drives through a construction site.

⚠ WARNING

Danger of incorrect steering intervention!
Certain objects or markings on the road may be erroneously recognized as lane markings.

- ▶ Always keep your hands on the steering wheel and be prepared to override the steering intervention.

Settings

Activation/deactivation in the instrument cluster

- › Press the button on the multifunction steering wheel.
- › Select *Lane Assist* .

Activation/deactivation in Infotainment

In the menu **MENU** › › .

Troubleshooting

Message regarding system unavailability

- › Clean the windscreen in the sensor area.
- › Stop the engine and restart again after a short time.
- › If the system is still not available, seek the help of a specialist garage.

Travel Assist

Usage

Travel Assist helps to keep the vehicle within the lane while controlling the speed of the vehicle.

Functionality

Travel Assist uses the functions Lane Assist and ACC.

⚠ WARNING

Risk of an accident!

- ▶ Always keep your hands on the steering wheel and be ready to take over the steering.
- ▶ The notes in the functional description of Lane Assist and ACC are to be taken into account.

Adaptive lane assist

This function keeps the driver within the selected position within the lane.

Status display in the instrument cluster display

is lit up – the system is activated, cruise control and adaptive lane guidance are active

is lit up – the system is activated, cruise control is active

is lit up – the system is activated, adaptive lane guidance is active

lights up – you have let go of the steering wheel, take over steering

lights up – you have released the steering wheel, take over steering immediately

Operating conditions

- ✓ The ACC is activated.
- ✓ The vehicle speed is max. 210 km/h.
- ✓ The lane markings are clearly visible.
- ✓ In vehicles with manual gearbox, the vehicle speed is higher than 30 km/h.

Function restriction

Travel Assist is only for support and does not absolve you from your responsibility for driving the vehicle.

The function may be restricted or unavailable in the following cases:

- ▶ The field of view of the sensor is limited by a dirty screen or an obstacle or a preceding vehicle.
- ▶ If the weather conditions are unfavourable.
- ▶ The vehicle is making a sharp turn.
- ▶ The vehicle is travelling on a sloping road or in ruts.
- ▶ When the driving lane is too narrow.

In addition to these restrictions, also note the ACC restrictions » [page 184](#).

⚠ WARNING

Danger of incorrect steering intervention!
Certain objects or markings on the road may be erroneously recognized as lane markings.

- ▶ Always keep your hands on the steering wheel and be prepared to override the steering intervention.

Settings

Activation

- › Press the  button on the multifunction steering wheel.

Regulation with the current speed and adaptive lane assist are started.

Deactivation

- › Depress the brake pedal.

Or:

- › Set the ACC lever in position **CANCEL** » [page 184](#).

i Additional settings are identical to ACC and Lane Assist.

Troubleshooting

Message regarding system unavailability

- › Follow the troubleshooting instructions in case of Lane Assist » [page 186](#) and ACC » [page 185](#).
- › If the system is still not available, seek the help of a specialist garage.

Lane change assist system Side Assist

Usage

The system uses optical signals in the exterior mirror to alert the driver to vehicles that could be dangerous when changing lanes.

Functionality

The system monitors the area both beside and behind the vehicle.

The system warns of an approaching vehicle through the indicator light  in the exterior mirror cover on the vehicle side, where the vehicle is recognized.

Driving situations in which a system warning occurs

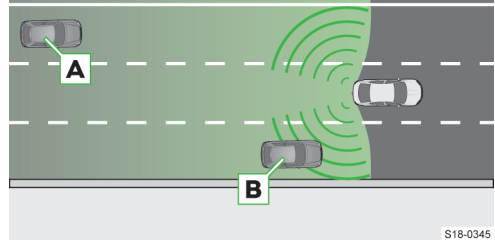

Your vehicle is being overtaken by vehicle **A**. The faster vehicle **A** approaches, the sooner the warning is given by the indicator light.

Vehicle **B** is overtaken by your vehicle at a speed that is faster by max. 10 km/h. If the speed is higher during the overtaking process, no warning will be provided by the indicator light.

Indicator light

 **illuminates** - There is another vehicle behind your vehicle

 **flashing** - There is another vehicle behind your vehicle, and the turn signal on the same side is switched on

For vehicles with Lane Assist, the indicator light will also flash if your vehicle crosses the lane markings in the direction of the approaching vehicle. The system will trigger a steering wheel vibration in this case.

For this, Lane Assist must be activated and the lane marking between the vehicles must be detected.

Operating conditions

- ✓ The driving speed is higher than 15 km/h.
- ✓ No accessories are connected to the trailer socket.

Function restriction

The system cannot detect lane width. For this reason, it may, for example, draw attention to a vehicle in a distant lane in the following cases:

- ▶ The vehicle is driving on a road with narrow lanes or on the lane edge.
- ▶ The vehicle is taking a turn.

The system can draw attention to objects along the road, such as high guard rails or noise barriers.

In the following cases, the system does not have to issue a warning of a vehicle, or the warning may be issued incorrectly:

- ▶ If the weather conditions are unfavourable.
- ▶ A very fast approaching vehicle.
- ▶ The vehicle is driving through a sharp bend or a roundabout.

Settings

In the instrument cluster display

In the menu *Assist systems*.

In Infotainment

In the menu **MENU** ›  › .

Troubleshooting

Message regarding system unavailability

- › Stop the engine and start again.
- › If the system is still not available, seek the help of a specialist garage.

Traffic sign recognition

Usage

The road sign recognition shows road signs in the display of the instrument cluster. This also indicates exceeding the speed limit.

WARNING

Road signs on the road always have priority over the road signs shown on the display.

Functionality

Displayed road signs

- ▶ Speed limits
- ▶ Overtaking prohibited
- ▶ Driving bans – one-way traffic
- ▶ Additional characters, e.g. speed limit in wet conditions

Towing a trailer

If a trailer or other accessory is connected to the trailer socket, trailer-relevant road signs are also displayed.

Driving on roads without speed limits

If you are on a road with no speed limits, the road signs  will appear in the display.

Example of road sign display



Example of additional characters



Example of several simultaneously recognised road signs.

 At the same time, a red display regarding the speed limit appears in the speedometer.

Speed units

The speed indications in the road signs shown refer to the speed units that are common in the country.

For example, the  display may refer to 30 km/h or 30 mph depending on the country.



Restriction

The system function may be restricted in the following cases:

- ▶ The sensor is blinded by the sun or oncoming traffic.
- ▶ The field of view of the sensor is limited by an obstacle or a preceding vehicle.
- ▶ If the weather conditions are unfavourable.
- ▶ The vehicle is moving at high speed.
- ▶ The road signs are hidden, damaged, or are non-standard.
- ▶ The road signs are attached to flashing neon signs.
- ▶ The navigation map documents are not up-to-date or not available.

Settings

Activation / deactivation and setting

In the Infotainment system, in the menu **MENU** ›  › .

■ Traffic Sign Recognition

- ▶ *Show in instrument cluster* – Activation/deactivation of the additional road signs in the display of the instrument cluster
- ▶ *Speed warning:* – Configures a warning when the speed limit is exceeded
- ▶ *Warning at over* – Increases the speed limit for the warning when exceeding the permitted speed

■ Trailer detection

- ▶ *Show road signs relevant to trailers* Activation/deactivation of the display of road signs relevant to trailers

- ▶ *Use for route calculation* - Activation/deactivation taking trailers in account for route calculation in navigation
- ▶ *Tap on maximum speed for trailers* - Setting the speed limits for trailer operation

Crew Protect Assist proactive occupant protection

Usage

The system of proactive occupant protection triggers measures to protect vehicle occupants in dangerous situations.

Functionality

If the system evaluates the situation as critical, it triggers the following safety measures:

- ▶ Open windows are closed except for a small gap.
- ▶ The sliding/tilting roof is closed.
- ▶ The front seat belts are tightened on the body.

i The system response depends on the selected driving mode.

Risk of frontal impact

Applies to vehicles with the Front Assist system.

The system triggers safety measures when it detects the impending danger of a frontal impact.



Driver inactivity hazard

Applies to vehicles with assist systems for emergency situations.

The system triggers safety measures when it detects the impending danger if the driver is inactive.

Function restriction

The function may be restricted or unavailable in the following cases:

- ▶ When deactivated in the infotainment in the menu **MENU** >  > 
- ▶ When deactivating the ASR or activating the ESC Sport
- ▶ When reversing
- ▶ If there is a malfunction in the ESC, reversible seat belt or airbag system
- ▶ If there is a malfunction or limitation of the Front Assist system
- ▶ If there is a malfunction or restriction of the Emergency Assist assist systems



Settings

Automatic activation

The system is automatically activated when the ignition is switched on.

Troubleshooting

Crew Protect Assist faulty

 illuminates together with  Message concerning unavailability or functional restriction

- ▶ Seek the help of a specialist garage.

Driver Alert fatigue detection assistant

Functionality

Driver Alert evaluates the steering behaviour. If it detects fatigue in the driver, a break is recommended. In the display of the instrument cluster, the following symbol lights up  from the isolation box.

WARNING

There will be no system warning during the so-called micro-sleep.

Resetting the break recommendation

The break recommendation is reset in the following cases:

- ▶ The vehicle stops and the ignition is switched off
- ▶ The vehicle stops, the seat belt is removed and the driver's door is opened
- ▶ The vehicle stops for more than 15 minutes



i In some situations, the system may erroneously issue a break recommendation.

Operating conditions

- ✓ Driving speed between 60-200 km/h.

Settings

Activation/deactivation

In the Infotainment system, in the menu **MENU** >  > .

Emergency situation assist system Emergency Assist

Usage

The assist systems for emergencies detect inactivity of the driver, which, for example, can be caused by a sudden loss of consciousness. The system then per-

190 Driver assist systems › Hill descent assistant

forms measures as safely as possible to decelerate the vehicle to a stop.

The assist systems are only available for vehicles with an automatic gearbox.

- ✓ The slope is at least 10 %.
- ✓ Neither the accelerator nor the brake pedal is pressed.
- ✓ The vehicle speed is max. 30 km/h.

Functionality

When the assist system detects inactivity on the part of the driver

- ▶ An acoustic warning signal sounds and a message appears in the instrument cluster display.
- ▶ If, after repeated warnings, the driver does not take over the steering, the hazard warning lights are switched on and the vehicle automatically brakes.
- ▶ After the vehicle has come to a standstill, the parking brake is switched on.

Interruption of automatic braking

- ▶ By pressing the brake or accelerator pedal
- ▶ By actively steering

Operating conditions

- ✓ Lane Assist is activated and the boundary lines of the traffic lane are recognised.
- ✓ ACC is enabled.

Hill descent assistant

Functionality

The Hill Hold Control helps to maintain a constant speed when driving downhill through automatic brake interventions.

The system also works when driving in neutral or when reverse gear is engaged.

⚠ **WARNING**

Risk of an accident!

The system cannot properly fulfil its function on slushy soil for physical reasons, e.g. ice or mud.

Status display in the instrument cluster display

☾ lit up in grey – the system is activated

☾ lit up white / green - the system intervenes

Change speed

The driving speed can be changed by pressing the brake or accelerator pedal. After releasing the pedal, the assist system maintains the current speed.

Operating conditions

- ✓ The engine is running.
- ✓ Offroad is activated.



Settings

Automatic activation

The system will be automatically activated when you turn on Offroad mode.

Activation/deactivation in Infotainment

The system is activated or deactivated in the following menu.

MENU >  > 

Or:

CAR > 

Park Assist systems

Park Pilot parking aid

Functionality

If an obstacle is detected, the Infotainment will display a visible message and an audible signal will sound.

The interval between the signals becomes shorter as the clearance is reduced. At a distance of less than 30 cm from the obstacle, a continuous tone sounds.

If the driver does not respond to the warning, the system triggers automatic emergency braking at speeds below 8 km/h in order to reduce the impact.

Automatic braking can be activated and deactivated in the infotainment.

Display

The recorded areas vary according to the equipment.

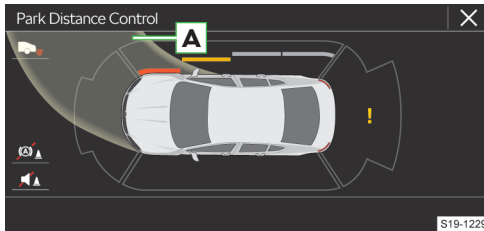

A Route controlled at the current steering angle

🔊 Acoustic signals on/off

🛑 One-time deactivation/activation of automatic braking

📺 Change to the rear view camera display

! System fault

■ Obstacle at a distance of less than 30 cm

■ Obstacle at a distance of more than 30 cm

□ Obstacle outside the route

Operating conditions

- ✓ The driving speed is lower than 15 km/h.
- ✓ No accessories are connected to the trailer socket.

Turn on/turn off

Switching on

- › Engage reverse gear.

Or:

- › Press the **P** button.

Automatic switch-on during forward travel

When approaching an obstacle at a speed of less than 10 km/h.

Automatic switch-on does not activate automatic braking.

Switching off

- › Disengage reverse gear.

Or:

- › Press the **P** button.

Automatic switch off

The driving speed is higher than 15 km/h.

Function restriction

In the following cases, the system does not have to issue a warning of an obstacle, or the warning may be issued incorrectly:

- ▶ If the weather conditions are unfavourable.
- ▶ The detected obstacles are moving.
- ▶ Sensor signals are not reflected by the surface of the obstacles.
- ▶ It is a small obstacle, e.g. a stone or a pillar.

Settings

The system settings are made in the infotainment system in the following menu:

CAR › 🏠 › **P**

Or:

MENU › 🚗 › 🏠 › **P**

Troubleshooting

After switching on, an audible signal sounds for 3 seconds and there is no obstacle near the vehicle

- › Seek the help of a specialist garage.

After switching on, the symbol **P flashes in the button**

- › Seek the help of a specialist garage.

After switching on, not all scanned areas are displayed on the Infotainment screen

- › Move the vehicle a few meters forwards or backwards.
- › If the scanned areas are still not displayed, seek the help of a specialist garage.

Rear view camera

Functionality

When reversing, the area behind the vehicle is displayed in the Infotainment screen complete with orientation lines.

I The camera is equipped with a cleaning system. Cleaning takes place automatically when the rear window is washed.

Orientation lines and functional surfaces

Orientation lines

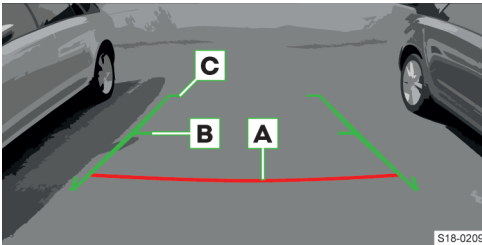

- A** Distance about 40 cm
- B** Distance about 100 cm
- C** Distance about 200 cm

The distance between the side lines corresponds approximately to the vehicle width including mirrors.

Function surfaces

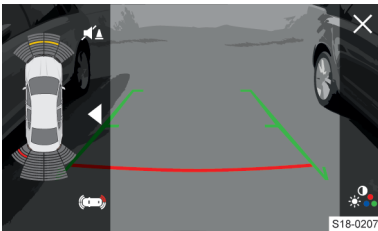

- X** / **↔** Turns off the display of the area behind the vehicle
- ☼** Brightness, contrast and colour settings of the screen
- 🔊** Switching audible parking signals on/off
- ◀▶** Switching the parking aid view on/off.
- 📺** Parking aid full screen view.

Operating conditions

- ✓ Boot lid closed
- ✓ Ignition on

- ✓ Driving speed less than 15 km/h

Operation

Switching on

- › Engage reverse gear.

Switching off

- › Disengage reverse gear.

Restriction

The camera image is distorted in contrast to the naked eye. The display may only be used to estimate the distance.

Some items may not be displayed properly on the screen. These include narrow columns, wire mesh fences, grids or road bumps.

Area View environment overview

Usage

The area view assists the driver in parking and manoeuvring by displaying the vehicle area.

Overview

General overview

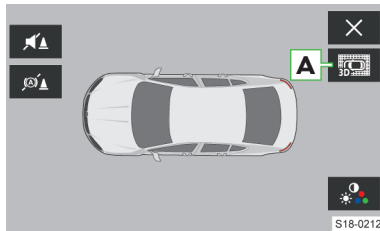

A 3D views:

- 📺** Top view
- 👁️** View obliquely from above
- 🚗** View from the side
- 📺** Overall view

By moving your finger across the screen, you can change the viewing angle.

Camera rear view

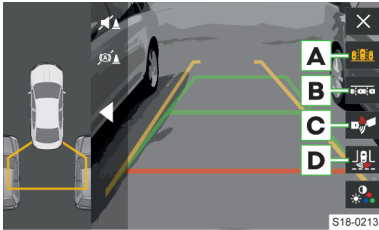

- A** Mode for transverse parking
- B** Mode for parallel parking
- C** Mode for driving up to a trailer/distance monitoring
- D** Mode for monitoring the area behind the vehicle (wide view)

The lines indicate the track, which is controlled at the current steering angle. The distance between the side lines corresponds approximately to the vehicle width including mirrors.

Mode for transverse parking

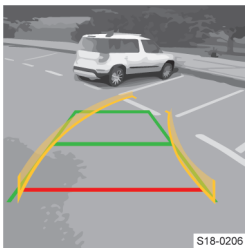

- › Stop the vehicle in front of a suitable parking space.
- › Reverse so that the yellow lines lead into the parking space.
- › At the latest, stop when the red line touches the rear boundary (e.g. curb).

Mode for parallel parking

- › In the screen, select the mode for parallel parking.
- › Turn on the indicator light for the side on which you want to park.

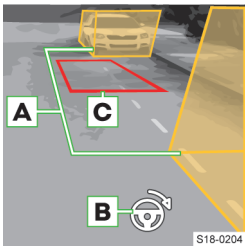

- › Stop the vehicle so that there are no obstructions in the gap between the auxiliary boxes **A** and the rear box does not extend over the side of the parking space (e.g. kerb).
- › Turn the steering wheel in the recommended direction **B** until the red colour of the trapezoidal border **C** turns green.

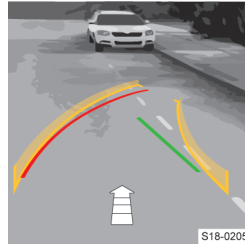

- › Hold the steering wheel in the adjusted position and reverse.
- › Stop the vehicle if the green line overlaps with the lateral boundary of the parking space (e.g. the curb) or if is displayed.
- › Countersteer until the yellow lane line crosses

- the red line for the required lane orientation.
- › Hold the steering wheel in the adjusted position and reverse.
- › Stop the vehicle at a safe distance from the obstacle or when is displayed.

Mode for driving up to a trailer/distance monitoring

The screen shows the area behind the vehicle in plan view.

On vehicles with a factory fitted tow-bar, this mode assists the driver when the vehicle is approaching a trailer draw bar. A line for approaching the trailer draw bar and lines for estimating distance are displayed on the screen.

For vehicles without a factory fitted tow bar, a line for monitoring the distance to obstacles is displayed on the screen at a distance of 40 cm behind the vehicle.

Mode for monitoring behind the vehicle

The area behind the vehicle is displayed on the screen.

Front camera view

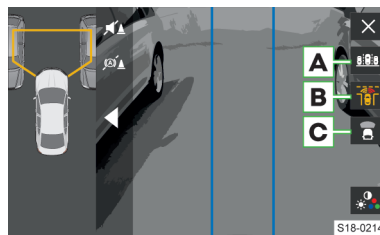

- A** Mode for transverse parking
The orientation lines are used for estimating distance as well as for displaying the route, which is controlled at the current steering angle.
- B** Mode for monitoring the area in front of the vehicle (wide view)
The area right in front of the vehicle is marked by the blue lines.
- C** Distance monitoring mode

Side camera view

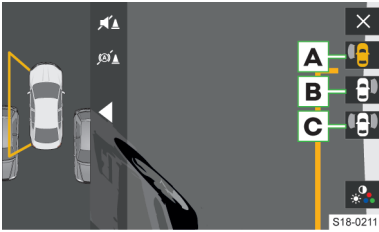

- A** Left side
- B** Right side
- C** Left and right side

The yellow line is shown at a distance of about 40 cm from the vehicle.

Operating conditions

- ✓ The ignition is switched on.
- ✓ The driving speed is lower than 15 km/h.

Operation

Switching on

› Engage reverse gear.

Or:

› Press the button.

Selecting the camera image

The respective camera image is selected by touching the screen in the Infotainment in the area next to, in front of or behind the vehicle silhouette. The selected area is highlighted on the screen by a yellow border.

Switching off

› Press the button.

Or:

› For vehicles with an automatic gearbox, put the selector lever in the **P** position.

Automatic shut-off

The automatic system shut-off occurs when driving forward at a speed over 15 km/h.

Restriction

The camera image is distorted in contrast to the naked eye. The display may only be used to estimate the distance.

Some items, such as thin posts, chain link fences, grilles or uneven road surfaces may not be properly displayed.

Objects directly beside the corners of the vehicle may be outside the field of view of the cameras and may therefore not be displayed on the screen.

Troubleshooting

After switching on, the symbol flashes in the button

› Seek the help of a specialist garage.

Rear Traffic Alert

Functionality

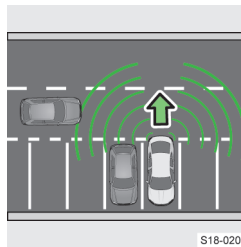

When reversing, the Rear Traffic Alert warns of approaching vehicles.

If the driver does not respond to the warning, the vehicle is braked automatically at a speed below 10 km/h.

Vehicle with Parking Aid

If an approaching vehicle is detected in the area behind your vehicle, a graphical warning is displayed in the Infotainment. At the same time, a continuous tone sounds.

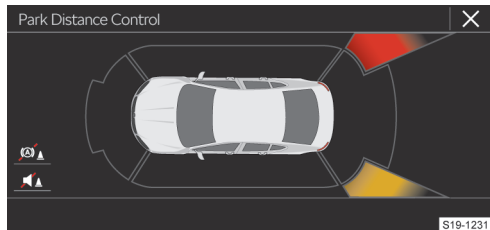

Vehicle in collision area - danger of collision!

Approaching vehicle

Vehicle without Parking Aid

If an approaching vehicle is detected in the area behind your vehicle, the a warning is displayed in the instrument cluster display, indicating to the driver to monitor the traffic behind. At the same time, an acoustic signal sounds.

Operating conditions

- ✓ No accessories are connected to the trailer socket.

Function restriction

Manoeuvre Assist's functionality may be limited in unfavourable weather conditions.

Settings

Activation/deactivation in the instrument cluster display



In the menu *Assist systems*.

Activation/deactivation in Infotainment

In the following menu:

CAR >  > P⊕

Or:

MENU >  >  > P⊕

Troubleshooting

Message regarding system unavailability

- › Stop the engine and start again.
- › If the system is still not available, seek the help of a specialist garage.

Park steering assistant

Usage

Park Assist helps drivers park in parallel and perpendicular parking places and to manoeuvre out of parallel parking spaces.

Functionality

The system looks for a parking space and only takes over the steering during the parking procedure or when leaving a parking place. The driver operates the pedals and the shift lever/gear selector.

The system displays information and notes on the instrument cluster display.

If the system detects a risk of collision, automatic emergency braking takes place to prevent a collision.

Operating conditions

- ✓ The driving speed is lower than 7 km/h.
- ✓ The ASR is activated and there is no intervention.
- ✓ There is no driver intervention in the automatic steering operation.
- ✓ No accessories are connected to the trailer socket.

Operation

Turn on/turn off

- › Press the P⊕ button.

When the system is switched on, the symbol lights up in the button P⊕.

Select the lane side for the parking procedure

The system automatically searches for a suitable parking space on the passenger side.

- › Press the driver's side indicator to find a parking space on this side of the road.

Operation while searching for a parking space

- › Drive past a number of parked vehicles at a distance of 0.5–1.5 m.
- › To search for a parking space across the road, drive slower than 20 km/h.
- › To search for a parking space along the road, drive slower than 40 km/h.

If the symbol ⊖ (km/h) appears in the display, reduce the driving speed. If the system finds a parking space, the display will show the recommended parking mode.

Changing the parking mode

If a suitable parking space is found, the following Park modes can be shown in the display.

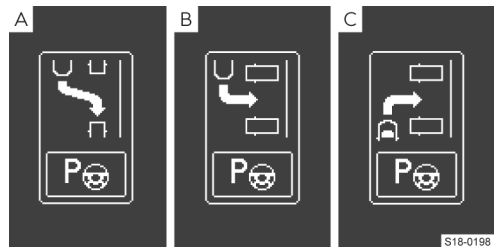

- Ⓐ Park backwards longitudinally
- Ⓑ Park backwards crosswise
- Ⓒ Park forwards across

The parking mode can be changed by pressing the button P⊕.

Press the button again P⊕ and the system is switched off.

- › To return to the original recommended parking mode, press the button P⊕ again.



Before the parking process

- › If a suitable parking space is found, stop and drive backwards or forwards as indicated by the arrow in the display.
- › When a steering intervention message is displayed, release the steering wheel. The steering operation is taken over by the system.

Parking operation



⚠ CAUTION

Risk of injury!

- ▶ Do not reach between the steering wheel spokes during the parking manoeuvre.
- ▶ Only operate the pedals and the shift / selector lever.
- ▶ Observe the area around the vehicle and drive backwards or forwards in accordance with the arrow in the display.
- ▶ As soon as the symbol  appears in the display and an audible signal sounds, stop the vehicle. The steering wheel is taken over accordingly. The symbol  goes out.
- ▶ Travel backwards or forwards in accordance with the arrow in the display.

As soon as the parking process is completed, the corresponding message is displayed and an audible signal sounds.

The parking procedure can be ended at any time by pressing the button .

 When partially parked in a suitable transverse parking space forward, press button . The parking process is completed by the system.

Exiting a parking space

- ▶ Press the  button.

When the system is switched on, the symbol lights up in the button .

- ▶ Follow the instructions on the screen.

Automatic speed reduction

If a speed of 7 km/h is exceeded during the parking process, the system will reduce the speed.

Upon the speed being exceeded by 7 km/h a second time, the parking process is terminated.

Function restriction

If the parking space is too small, it is not possible to use the Park Assist to initiate a parking manoeuvre. A message is shown on the instrument cluster display.

Do not use the Park Assist in the following cases:

- ▶ The vehicle is moving on unpaved or slippery surfaces.
- ▶ If snow chains or a spare wheel are mounted on the vehicle.
- ▶ If the system chooses an inappropriate parking space for parking.

Troubleshooting

Message regarding system unavailability

- ▶ Stop the engine and start again.
- ▶ If the system is still not available, seek the help of a specialist garage.

Incorrect resulting position of the vehicle in the parking space

The correct parking procedure depends on the size of the wheels. If other wheels approved by ŠKODA AUTO are fitted, have the system readjusted by a specialist garage.

Trailer assist trailer manoeuvring aid

Usage

The trailer manoeuvring aid helps the driver when reversing with a trailer.

What you should be mindful of

Use the system extremely carefully in the following cases:

- ▶ The vehicle is moving on unpaved or slippery surfaces.
- ▶ If snow chains or a spare wheel are mounted on the vehicle.

ⓘ NOTICE

The system does not warn of obstacles or monitors the area behind the trailer. The driver must check themselves as to whether there are no obstacles in the area behind the trailer.

Functionality

The rear camera monitors the bending angle of the trailer drawbar. The system executes appropriate steering movements to position the trailer in the desired direction. The driver operates the pedals and the shift lever/gear selector.

The driver sets the desired direction with the external mirror knob.

Operating conditions

- ✓ The driving speed is lower than 5 km/h.
- ✓ The ASR is activated and there is no intervention.
- ✓ The luggage compartment lid is closed.
- ✓ The driver's door is closed.
- ✓ It is a uniaxial or biaxial trailer hitched without a steered axle.
- ✓ The trailer drawbar is not covered.
- ✓ The trailer is not veering too much.

Operation

Before switching on

- › Make several turns or cornering with the trailer attached.

The system determines the drawbar length in order to use the maximum yaw rate.

Switch on the system

- › Stop the vehicle.
- › Engage reverse gear.
- › Release the steering wheel and press the PⓂ button.

Manoeuvring

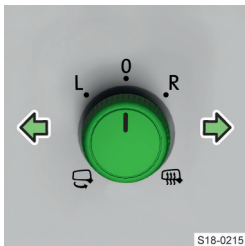

- › Tilt the exterior mirror knob to the right or left.

The setting menu is shown on the instrument cluster display.

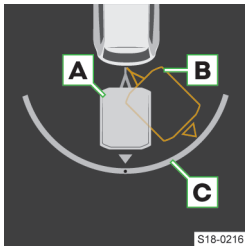

- A** Current trailer position
- B** Target trailer position
- C** Manoeuvring angular dimension

- › Tilt the knob to the right or left to set the trailer's target position.
- › Start reversing.

The setting can be corrected when reversing.

- › Stop as soon as the trailer's target position is reached.

⚠ CAUTION

Risk of injury!

- ▶ Do not reach between the steering wheel spokes during the parking manoeuvre.
- ▶ Only operate the pedals and the shift / selector lever.

Straighten the trailer

- › Tilt the knob backwards.
- › Carefully reverse and drive forwards until the desired position of the trailer combination is achieved.

Switch off the system

- › Press the PⓂ button.

Automatic system shut-off

If the following situations occur during the manoeuvring process, an automatic system shutdown and a braking intervention take place.

- ▶ The PⓂ button is pressed.
- ▶ The driver's door is opened.
- ▶ The steering wheel is gripped.
- ▶ The driving speed is too high.
- ▶ The trailer veered too much.

Engine, exhaust system and fuel

Bonnet

Opening the bonnet

Before opening

- › Make sure the windscreen wiper arms are folded down onto the windscreen.
- › Keep everyone away from the engine compartment.

Opening

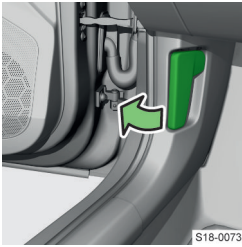

- › Pull the release lever underneath the dash panel.



- › Release the lock.



- › Open the bonnet.
- › Remove the bonnet stay from the holder and insert the end of the stay into the opening in the bonnet.

Closing

- › Lift the bonnet.
- › Unhook the bonnet stay and insert it into the holder.
- › Fold the bonnet down and release it with a distance of 30 cm remaining.
- › Check that the bonnet is closed.

ⓘ NOTICE

- › Do not press down on an unclosed bonnet.
- › Open and close the flap again.

Engine oil

Checking the fill level and topping up

Test conditions

- ✓ The vehicle is on a horizontal surface
- ✓ The parked engine is warm

Checking the level

- › Wait a few minutes for the engine oil to flow back into the oil sump.
- › Remove the dipstick and wipe with a clean cloth.
- › Insert the dipstick as far as it will go and pull it out again.
- › Read the oil level and push the dipstick back in again.

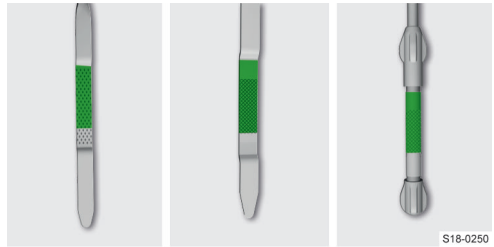

The oil level must be within the marked range.

ⓘ NOTICE

Risk of damage to the engine and the exhaust system!

- › The oil level must not be outside the marked range. If it is not possible to top up the engine oil or if the oil level is above the marked range, do not continue driving. Stop the engine and seek the help of a specialist garage.
- › Do not use any oil additives.

Consumption

Depending on driving style and operating conditions, the engine consumes some oil, up to 0.5 l/1000 km. Consumption may be higher over the next 5000 km.

Refilling

- › Unscrew the cover of the engine oil filler opening.
- › Top up the oil to the correct specification in 0.5 litre portions.
- › Check the oil level.
- › Screw on the cover of the engine oil filler opening.

Specification

Ask a specialist garage for the correct engine oil specification for your vehicle.

If no oil of the correct specification is available, **max. 0.5 l** of oil with the following specifications may be used until the next oil change:

- › **Petrol engines:** VW 504 00, VW 508 00, ACEA C3, ACEA C5

- **Diesel engines:** VW 507 00, VW 509 00, ACEA C3, API CJ-4

For vehicles without a particulate filter, VW 505 01 can be optionally used.

Changing

Have the oil changed by a specialist garage.

Troubleshooting

Engine oil pressure too low

 flashes, lights up at the same time ⚠

or

 flashes, lights up at the same time ⚠

- › Check the engine oil level.

The oil level is OK, the warning light continues to flash:

- › Stop the engine and seek the help of a specialist garage.

Engine oil level too low

 illuminates together with ⚠

or

 illuminates together with ⚠
Message regarding required engine oil top up

- › Check the engine oil level, top up with oil if required.

Engine oil level too high

 illuminates together with ⚠

or

 illuminates together with ⚠
Message regarding the need to reduce the engine oil level

- › Check the engine oil level.

The oil level is too high:

- › Drive on, exercising appropriate caution.
- › Seek the help of a specialist garage.

Engine oil level sensor impaired

 illuminates together with ⚠

or

 illuminates together with ⚠
Message regarding the engine oil sensor

- › Drive on, exercising appropriate caution.
- › Seek the help of a specialist garage.

Coolant

Coolant temperature gauge

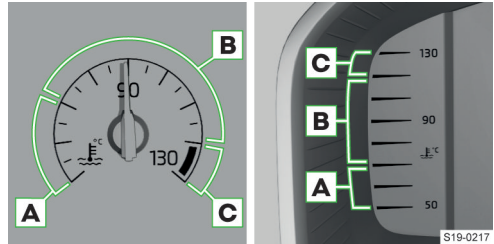

- A** Cold area
 - › Avoid high engine speed.
- B** Operating range
- C** High temperature range

Checking the fill level and topping up

Test conditions

- ✓ The vehicle is on a horizontal surface
- ✓ The engine is turned off and cooled

Checking the level



The fill level must be within the marked range.

- › If the fill level is below the mark **MIN**, top up the coolant.

ⓘ NOTICE

Danger of damage to the engine compartment!

- Do not top up the coolant above the marked area. The coolant could be forced out of the cooling system when heated.

ⓘ NOTICE

There must be a small quantity of coolant in the tank.

- Do not add coolant when the tank is empty.
- Stop driving! Seek the help of a specialist garage.

Refilling

⚠ CAUTION

Risk of scalding!

The cooling system is pressurised.

- ▶ Do not open the cap of the coolant expansion tank while the engine is warm. Let the engine cool down.
- ▶ Place a wipe on the lid of the tank and carefully unscrew the lid.
- ▶ Refill with coolant of the correct specification.
- ▶ Screw on the cap until it clicks into place.

Specification

To refill the coolant additive use G12evo (TL 774 L).



ⓘ NOTICE

Risk of damage to the cooling system and the engine!



Adding coolant that does not conform to the correct specification can reduce the corrosion protection of the cooling system.

Troubleshooting

Coolant level is too low

 illuminates together with 

or

 illuminates together with 
Message concerning the required coolant check

- ▶ Check the coolant level.



If the coolant level is OK:

- ▶ Check the fuse for radiator fan, replace if required » [page 208, Replacing a fuse](#).



If the fuse is OK but the indicator light lights up again:

- ▶ Stop driving! Seek the help of a specialist garage.

Coolant temperature too high



 illuminates together with 

or



 illuminates together with 
Report regarding the engine overheating

- ▶ Stop driving.
- ▶ Stop the engine and allow it to cool.
- ▶ Drive on after the indicator light goes out.

Engine fault

 illuminates together with 

or

 illuminates together with 

- ▶ Stop driving!

- ▶ Stop the engine and seek the help of a specialist garage.

There is no coolant of the correct specification available

- ▶ Top up with distilled or demineralised water.
- ▶ Have the correct coolant mixing ratio corrected by a specialist garage as soon as possible.

Another substance was used for topping up, other than distilled or demineralised water:

- ▶ Have the coolant changed by a specialist garage.

It is not possible to top up with a sufficient amount of coolant

- ▶ Stop driving.
- ▶ Stop the engine and seek the help of a specialist garage.

There is a loss of coolant

- ▶ Top up the coolant and seek the help of a specialist garage.

Engine electronics

Troubleshooting

Petrol engine control faulty

EPC illuminates

Driving in emergency mode is possible - a noticeable reduction in engine performance may occur.

- ▶ Continue driving, exercising appropriate caution, and seek the help of a specialist garage.

Diesel engine control faulty

 flashes

Driving in emergency mode is possible - a noticeable reduction in engine performance may occur.

- ▶ Continue driving, exercising appropriate caution, and seek the help of a specialist garage.

Diesel preheating system faulty

 illuminates, or does not illuminate after the ignition is switched on

Driving in emergency mode is possible - a noticeable reduction in engine performance may occur.

- ▶ Continue driving, exercising appropriate caution, and seek the help of a specialist garage.

Particle filter

Troubleshooting

Clogged particle filter

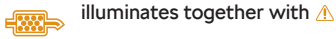

or

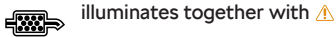

- › Clean the filter.

i When the indicator light is on, it must be assumed that fuel consumption will be higher, engine power will be reduced, and the START-STOPP function will not be available.

Filter cleaning

Conditions for cleaning

- ✓ The engine is warm.
- ✓ For vehicles with manual transmission, observe the gear recommendation shown in the display of the instrument cluster.

Procedure for vehicles with diesel engines

- › Drive at a speed of at least 60 km/h at engine speeds of at least 2000 rpm.

If the filter is successfully cleaned, the indicator light goes off. or .

If the indicator light or does not go off within 40 minutes, no filter cleaning was performed.

- › Continue driving, exercising appropriate caution, and seek the help of a specialist garage.

Procedure for vehicles with petrol engines

- › Drive at a speed of at least 80 km/h at engine speeds between 3000-5000 rpm.
- › Release the accelerator pedal and let the vehicle roll with the gear engaged for a few seconds.
- › Repeat this procedure several times.

If the filter is successfully cleaned, the indicator light goes off. or .

If the indicator light or does not go off within 30 minutes, no filter cleaning was performed.

- › Continue driving, exercising appropriate caution, and seek the help of a specialist garage.

Exhaust control system

Troubleshooting

Emission control system faulty

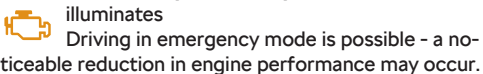

- › Continue driving, exercising appropriate caution, and seek the help of a specialist garage.

Fuel filter

Troubleshooting

Water in the diesel fuel filter

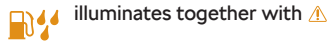

or

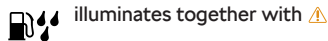

- › Continue driving, exercising appropriate caution, and seek the help of a specialist garage.

Radiator blinds

Usage

The radiator blinds reduce emissions harmful to the environment and CO₂-Emissions and saving fuel.

Troubleshooting

If the display of the instrument cluster shows a message relating to the function restriction of the blinds, the maximum speed of the vehicle is limited to 160 km/h.

The cause may be ice or snow in the area around the blinds. After the ice or snow has thawed, the blinds are functional again.

- › Should the impairment not be due to ice or snow, assistance from a specialist should be sought.

Fuel filler flap

Opening the fuel filler flap



- › Press the flap and open it.

S19-0295

AdBlue

Regulations

Only use AdBlue® that corresponds with the ISO 22241-1 standard. Do not add additives to AdBlue®.

AdBlue® is a registered trademark of VDA and is also popular as AUS 32 (Aqueous Urea Solution) or DEF (Diesel Exhaust Fluid).

Functionality

To reduce pollutant emissions, a urea solution is automatically injected into the exhaust system - AdBlue®.

AdBlue® freezes at temperatures below -11 C. The system function is ensured by automatic heating.

Checking the fill level and topping up

Checking the level

The AdBlue® level is monitored automatically.

The range with the existing AdBlue® tank fill level as well as the indication of the minimum and maximum AdBlue® top up quantity can be viewed in the driving data in the instrument cluster display under the menu item .

If the range with the existing AdBlue® tank fill level drops to 0 km, it is not possible to start the engine.

- › If possible, top up AdBlue® to the maximum level.

Requirements for refilling

- ✓ Vehicle unlocked
- ✓ Stationary heating switched off
- ✓ Ignition off
- ✓ The vehicle is on a horizontal surface

Methods of refilling

- ▶ With the fuel nozzle at the petrol station
- ▶ With the refill bottle or from the canister
- ▶ At a specialist garage

For refilling using refill bottles or canisters, we recommend using refill bottles and canisters from ŠKODA original parts. The refill bottles are equipped with overflow protective function.

Refilling

- › Open the tank flap.

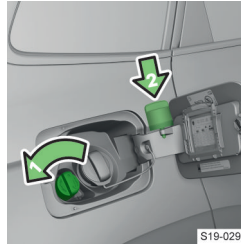

- › Turn the tank cap in the direction of the arrow and remove it.
- › Place the tank cap on the tank flap.
- › Refill AdBlue®.

The AdBlue® tank is full when the fuel nozzle switches off or as soon as no more AdBlue®

flows out of the refill bottle. Do not continue refilling.

- › Place the tank cap on the filler neck and turn it in the opposite direction to the arrow until it clicks into place.
- › Close the tank flap and click into place.
- › Before starting the engine, leave the ignition on for 30 seconds to allow the system to detect the refilling.

ⓘ NOTICE

Risk of damage to the system for injecting AdBlue® in to the exhaust system!



- ▶ Do not exceed the maximum refill quantity specified in the instrument cluster.
- ▶ The service life of AdBlue® is 4 years. If the tank contents are not consumed within this period, have them replaced by a specialist garage. When topping up, do not use AdBlue® that is past its expiry date.

Troubleshooting

AdBlue® -Level too low

-  or  or  illuminates
- › Refill AdBlue®.

AdBlue® -system malfunction.

-  or  or  illuminates
- › Seek the help of a specialist garage.

Technical data

AdBlue®-tank filling level is about 12 litres.

Petrol

What you should be mindful of

⚠ DANGER

Risk of death!

Fuel and fuel vapours are explosive.

ⓘ NOTICE

Risk of serious damage to the engine and the exhaust system!

▶ **Never run the fuel tank completely empty!**

If you would like to operate your vehicle in a country other than that intended for vehicle operation, please contact a ŠKODA Partner. They will let you know whether a suitable fuel is offered in the associated country.

Regulations

Standards

Petrol must comply with European standard EN 228 (in Russia, GOST 32513-2013).

Only use **unleaded petrol** that contains **max 10%** bi-ethanol (**E10**).

ⓘ We recommend using petrol with additives, which is available at petrol stations at the petrol pumps.

Octane number

Use the petrol with the octane number prescribed for your vehicle.

Petrol with an octane number that is one **higher** than the one prescribed for your vehicle can be used without restriction.

ⓘ NOTICE

Risk of damage to the engine and the exhaust system!

- ▶ When petrol with a lower than the prescribed octane is used, only continue driving at mid-range engine speeds and with minimal strain on the engine.
- ▶ Refuel using petrol of the prescribed octane number as soon as possible.
- ▶ Do not use petrol with an octane number that **lower** than **91**!

Prescribed petrol 95 / min. 92 or 93 RON / ROZ

We recommend using petrol **95 ROZ**.

Optionally, the petrol **92** or **93 ROZ** can be used (slight power loss, a slightly increased fuel consumption).

In an **emergency**, **91 RON** petrol may be used (low power loss, slightly increased fuel consumption).

Specified petrol is unleaded, min. 95 RON / ROZ

Use min. **95 ROZ** petrol.

Using higher octane petrol than **95 RON** may result in improved performance and lower fuel consumption.

In an **emergency 91. 92** or **93 RON** may be used (low power loss, slightly increased fuel consumption).

Prescribed petrol 98 / (95) RON / ROZ

We recommend using petrol **98 ROZ**.

95 RON petrol may be used as an option (low power loss, slightly increased fuel consumption).

In an **emergency 91. 92** or **93 RON** may be used (low power loss, slightly increased fuel consumption).

Additive

ⓘ NOTICE

Risk of damage to the engine and the exhaust system!

- ▶ Do not use petrol containing metal-based additives, e.g. manganese, iron, lead, and do not use, for example, any LRP-petrol - lead replacement petrol.
- ▶ Do not add any additional additives to the petrol in accordance with EN 228.
- ▶ If petrol is not used in accordance with EN 228, we recommend obtaining information from a specialist company regarding the possible use of petrol additives approved by ŠKODA AUTO.

Requirements for refuelling

- ✓ Vehicle unlocked
- ✓ Stationary heating switched off
- ✓ Ignition off

Refilling

- › Open the tank flap.

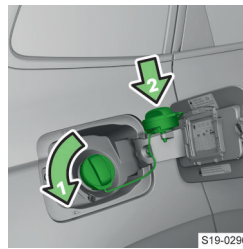

- › Turn the tank cap in the direction of the arrow and remove it.
- › Place the tank cap on the tank flap.
- › Insert the fuel nozzle into the fuel filler neck up to the stop and refuel.
- › Do not continue refuelling after the fuel nozzle switches off.
- › Remove the fuel nozzle and put it back on the petrol pump.
- › Place the fuel cap on the fuel filler neck and turn it in the opposite direction to the arrow until it clicks into place.
- › Close the tank flap and click into place.

Troubleshooting

If fuel other than unleaded petrol has been used as per standards applicable to your vehicle

- › Neither start the engine nor switch on the ignition.
- › Seek the help of a specialist garage.

Technical data

The fuel prescribed for your vehicle is indicated on a sticker on the inside of the fuel filler flap.

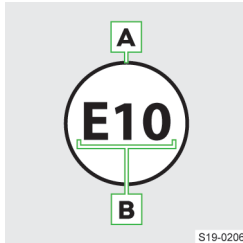

- A** Unleaded petrol
- B** Organic share as a percentage

The fuel capacity for vehicles with front wheel drive is about 50 litres, and for vehicles with four-wheel drive about 55 litres, with about 6 litres as reserve.

 illuminates - the fuel level has reached the reserve area.

Diesel

What you should be mindful of

⚠ DANGER

Risk of death!
Fuel and fuel vapours are explosive.

ⓘ NOTICE

Risk of serious damage to the engine and the exhaust system!

- › **Never run the fuel tank completely empty!**

If you would like to operate your vehicle in a country other than that intended for vehicle operation, please contact a ŠKODA Partner. They will let you know whether a suitable fuel is offered in the associated country.

Regulations

Standards

The diesel fuel must comply with European standard EN 590 (in Russia, GOST 32511-2013 or GOST R 55475-2013).

Only use a **diesel fuel** that contains a **maximum** of 7 % biodiesel (**B7**).

i We recommend using diesel with additives, which is available at petrol stations at the petrol pumps.

Operation in different weather conditions

Only use a diesel fuel according to the current or the expected weather conditions.

Additive

ⓘ NOTICE

Risk of damage to the engine and the exhaust system!

- › Do not use RME biofuel, even as a diesel fuel additive.
- › Do not add any additional additives to the diesel in accordance with EN 590.
- › If diesel is not used in accordance with EN 590, we recommend obtaining information from a specialist company regarding the possible use of diesel additives approved by ŠKODA AUTO.

Requirements for refuelling

- ✓ Vehicle unlocked
- ✓ Stationary heating switched off
- ✓ Ignition off

Refilling

Misfuelling protection

The fuel filler neck on diesel vehicles may be equipped with a misfuelling protection device.

In some countries, the diameter of the diesel fuel nozzle may be identical to that of the petrol nozzle. Before driving in these countries, have the protection device removed by a specialist garage.

Refilling

- › Open the tank flap.

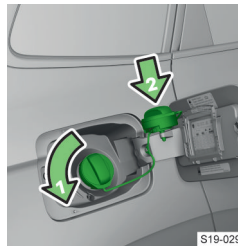

- › Turn the tank cap in the direction of the arrow and remove it.
- › Place the tank cap on the tank flap.
- › Insert the fuel nozzle into the fuel filler neck up to the stop and refuel.

Do not continue refuelling after the fuel nozzle switches off.

- › Remove the fuel nozzle and put it back on the petrol pump.
- › Place the fuel cap on the fuel filler neck and turn it in the opposite direction to the arrow until it clicks into place.

- › Close the tank flap and click into place.

Troubleshooting

If fuel other than diesel has been used as per applicable standards

- › Neither start the engine nor switch on the ignition.
- › Seek the help of a specialist garage.

The diesel nozzle cannot be inserted correctly into the tank filler neck

- › If the nozzle cannot be inserted correctly into the tank filler neck, move it slightly back and forth when plugging it in.

Technical data

The fuel prescribed for your vehicle is indicated on a sticker on the inside of the fuel filler flap.

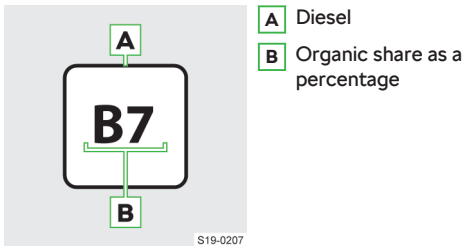

The fuel capacity for vehicles with front wheel drive is about 50 litres, and for vehicles with four-wheel drive about 55 litres, with about 6 litres as reserve.



illuminates - the fuel level has reached the reserve area.

12 volt vehicle battery and fuses

12 volt vehicle battery

What you should be mindful of

Explanation of the warning symbols on the 12-volt vehicle battery



Wear safety goggles!



The battery acid of the 12-volt vehicle battery is very caustic. Wear gloves and eye protection.



Keep fire, sparks and open light away from the 12 volt vehicle battery! Do not smoke!



When charging the 12 volt vehicle battery, a highly explosive gas mixture is produced!



Keep children away from the 12 volt vehicle battery!



Refer to the owner's manual!

Functionality - Protection against discharge of the 12 volt vehicle battery

Possible causes for the discharge of the 12 volt vehicle battery

- ▶ Worn 12 volt vehicle battery
- ▶ Frequent short journeys
- ▶ Low temperatures
- ▶ Vehicle stationary for a long period of time

Automatic system-related discharge protection measure with regard to the 12 volt vehicle battery

- ▶ Increasing the engine idling speed
- ▶ Switching off certain consumers or limiting their power

Recommended measure to be taken when vehicle is stationary for more than three weeks

- › Disconnect the ⊖ terminal of the 12 volt vehicle battery.

Checking and charging the 12 volt vehicle battery

Checking the condition

The condition of the 12 volt vehicle battery is checked by a specialist garage during servicing.

Checking the acid level

Applies to a 12 volt vehicle battery with an acid level indicator.

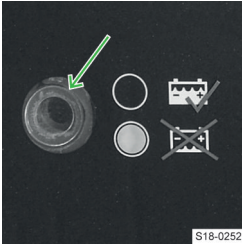

- › Tap on the indicator before testing, to clear air bubbles.
- ▶ Black colour - the acid level is OK.
- ▶ Colourless or pale yellow colour - acid level is too low, the 12 volt vehicle battery must be replaced.

Requirements for charging a 12 volt vehicle battery

- ✓ Ignition off
- ✓ Power consumers switched off

12 volt vehicle battery charging

To charge the 12 volt vehicle battery fully, set a charging current of max. of 0.1 times the battery capacity.

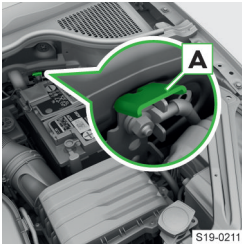

Earth point

- › Connect the ⊕ terminal of the charger to the ⊕ terminal of the 12 volt vehicle battery.
- › Connect the ⊖ terminal of the charger to the earth point **A**.
- › Plug the charger's power cable into the socket and switch on the device.

- › After charging, switch off the charger and unplug the power cable from the socket.
- › Disconnect the charger terminals from the 12 volt vehicle battery.

⚠ WARNING

Risk of explosion!

- ▶ During charging, hydrogen is released. An explosion can also be caused by sparks, for example, when disconnecting or loosening the cable connector.
- ▶ Never charge a frozen or thawed 12 volt vehicle battery.
- ▶ Do not carry out the so-called quick charging of the 12 volt vehicle battery yourself, but have it carried out by a specialist garage.

① NOTICE

A flat 12 volt vehicle battery can freeze easily!

Troubleshooting

The 12 volt vehicle battery does not charge while the engine is running



or illuminates

- › Seek the help of a specialist garage.

Engine fault



or illuminates

- › Stop driving!

- › Stop the engine and seek the help of a specialist garage.

Disconnecting, connecting and replacing

⚠ CAUTION

Risk of fire!

- ▶ Do not mix up the connection cables.

Disconnecting

- › Close the electric boot lid, the tilting/sliding sunroof, all windows and the electric sunblind.
- › Switch off the ignition and any connected power consumers.
- › Disconnect the ⊖ terminal and then the ⊕ terminal.

Connecting

- › Connect the ⊕ terminal and then the ⊖ terminal.

After switching on the ignition, the indicator lights light up from the isolation box.

- › If, after a short distance, one of the above-mentioned indicator lights does not go out, seek the help of a specialist garage.

Operate these vehicle functions after disconnecting and connecting the 12 volt vehicle battery

- ▶ Clock setting » page 65.
- ▶ Window operation » page 29.
- ▶ Operation of the tilting/sliding sunroof » page 30.
- ▶ Sunblind » page 31.

Changing

The new 12 volt vehicle battery must have the same parameters as the original battery. Have the replacement carried out by a specialist garage.

Using the jump-starting cable

Usage

With the help of jump start cables, a vehicle with a discharged or defective 12-volt vehicle battery can be started using the 12-volt vehicle battery of another vehicle.

What you should be mindful of

⚠ WARNING

Risk of explosion and chemical burns!

- ▶ Do not jump start with the 12 volt vehicle battery of another vehicle under the following conditions:
 - ▶ The discharged 12 volt vehicle battery is frozen. A discharged 12 volt vehicle battery may already freeze at temperatures just below 0 °C.
 - ▶ The acid level of the 12-volt vehicle battery is too low » page 205.

Use jump leads with a sufficient cross section and insulated terminal clamps.

The rated voltage of both batteries must be 12V. The capacity (in Ah) of the 12 volt charging vehicle battery must not be significantly lower than the capacity of the discharged 12 volt vehicle battery.

Use another vehicle's 12 volt vehicle battery to operate the vehicle

⚠ WARNING

Risk of injury! Danger of damage to vehicle!

- ▶ Lay the jump start cables so that they cannot become caught by rotating parts in the engine compartment.

ⓘ NOTICE

Short circuit!

- ▶ The non-insulated parts of the terminal clamps must not touch each other.
- ▶ The cable connected to the positive pole of the 12 volt vehicle battery must not come into contact with electrically conductive vehicle parts.
- ▶ The vehicles must not touch each other.

Connect the jump start cable

- ▶ Switch off the ignition.
- ▶ Connect the terminal clamps of the jump start cables in the order shown in the legend.

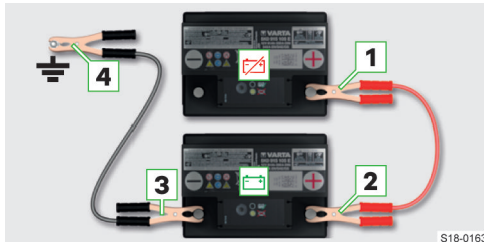

⊖ discharged 12 volt vehicle battery

⊕ current-supplying 12 volt vehicle battery

1 ⊕ -pole of the discharged 12-volt vehicle battery

2 ⊕ -pole of the current-supplying 12 volt vehicle battery

3 ⊖ -pole of the current-supplying 12 volt vehicle battery (or earth point)

4 ⊕ Earth point of the vehicle with discharged 12 volt vehicle battery

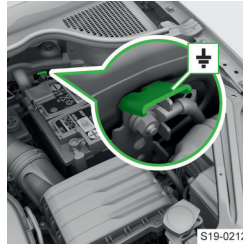

Earth point

Start the engine

- ▶ Start the engine of the current-giving vehicle and let it idle (applies to vehicles with combustion engine)

Or:

- ▶ Switch on the electric drive of the vehicle supplying power (applies to vehicles with an electric motor).
- ▶ Start up the vehicle with the discharged 12 volt vehicle battery.
- ▶ If the engine of the vehicle with the discharged 12 volt vehicle battery does not start within 10 seconds, repeat the starting procedure after approximately 30 seconds.

Disconnecting the cable

- ▶ Disconnect the cables in the reverse order from connection.

Fuses

What you should be mindful of

ⓘ NOTICE

Fire hazard and risk of damage to the electrical system.

- ▶ Do not repair fuses or replace them with stronger fuses.
- ▶ Replace the defective fuse with a new fuse with the same amperage.
- ▶ We recommend using replacement fuses from the ŠKODA Genuine Accessories range. These guarantee reliable and safe protection of the vehicle's electric system.
- ▶ If a newly inserted fuse blows again, seek the help of a specialist garage.

ⓘ One fuse may belong to several consumers. One consumer may have several fuses.

Functionality

Fuses protect the vehicle systems from damage caused by excessive current. The fuse blows when the current is exceeded.

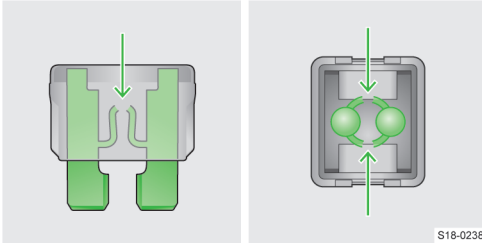

S18-0238

Blown fuse

Conditions for replacing a fuse

- ✓ Ignition key removed (vehicle without starter button)
- ✓ Ignition switched off and driver's door open (vehicle with starter button)
- ✓ All consumers switched off

Replacing a fuse

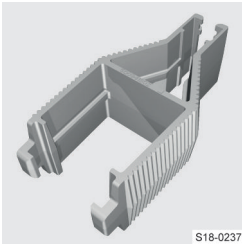

S18-0237

- › Replace the fuse with the clamp located on the inside of the fuse box cover in the engine compartment.
- › Use the appropriate end of the clamp according to the fuse dimensions.

Fuses in the dash panel

Overview

Access to fuses – left-hand drive

- › Open the storage compartment on the driver's side.



S19-0085

- › Press the button and open the tray.
- › Change the fuse.
- › Close the storage compartment.

Access to fuses – right-hand drive

- › Open the storage compartment on the passenger's side.



S19-0279

- › Loosen the brake rod of the storage compartment.

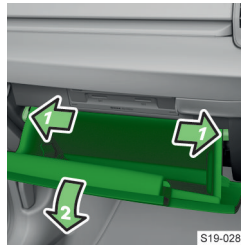

S19-0280

- › Press the locking lugs, the storage compartment folds down.

- › Change the fuse.
- › Insert and lock the brake rod.
- › Close the storage compartment.

Fuses overview

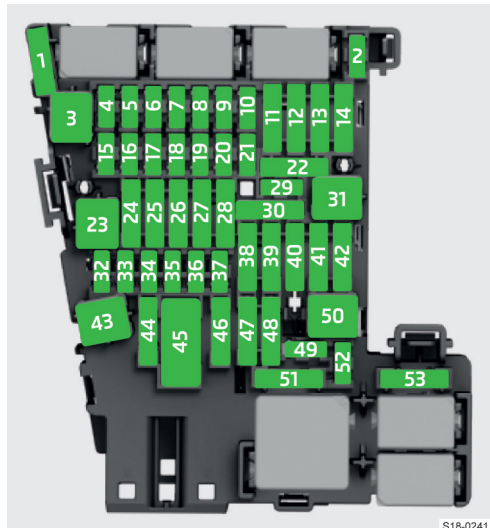

S18-0241

Fuse number	Consumer
1	SCR (AdBlue®)
2	Heated steering wheel

Fuse number	Consumer
3	Not used
4	Not used
5	Databus
6	Alarm system sensor
7	Front and rear air conditioning, auxiliary heater receiver, rear window heating, automatic gearbox, ignition key lock (vehicle with automatic transmission)
8	Light switch, rain sensor, parking brake, ambient lighting, headlights
9	Control lever under the steering wheel
10	Infotainment screen
11	Light - left side
12	Infotainment
13	Left side belt tensioner
14	Air blower for air conditioning, heating
15	Electric steering lock
16	USB ports, diagnostics connector, Phonebox
17	Instrument cluster, emergency call
18	Rear view camera, Area View
19	KESY (keyless locking and starting system)
20	SCR (AdBlue®), braking system
21	All-wheel drive
22	Tow hitch
23	Panorama sliding/tilting roof
24	Light - right side
25	Central locking- front and rear door left, power window - left, exterior mirrors left - heating, fold-in function, setting the mirror surface
26	Heating of the front seats
27	Interior lighting
28	Tow hitch
29	USB charging function - at the rear and on the interior mirror
30	Not used
31	Opening the boot lid
32	Parking aid, Park Assist, "blind spot" detection
33	Airbag
34	Air conditioning, reversing light switch, interior mirror with automatic dimming, heated seats, parking brake, light switch, strip with buttons, sports sound generator
35	Diagnostic connection, front camera, distance monitoring (e.g. ACC, Front Assist)
36	LED headlight - right
37	LED headlight - left
38	Tow hitch
39	Central locking - front and rear door right, power windows - right, right ex-

Fuse number	Consumer
	ternal mirror - heating, folding function, mirror surface adjustment
40	12-volt power outlets
41	Right side belt tensioner
42	Locking (luggage compartment lid, rear doors, fuel filler flap), headlight cleaning system, front and rear windscreen washer
43	Music amplifier
44	Tow hitch
45	Electrical operation of driver's seat
46	230 volt socket
47	Rear window wiper
48	Not used
49	Engine starting, clutch pedal switch
50	Not used
51	Seat heating - rear
52	Shock absorber adjustment (adaptive suspension)
53	Heated rear window

Fuses in the engine compartment

Overview

Access to the fuses

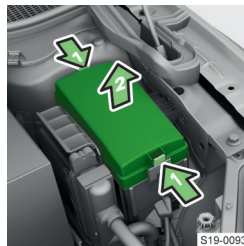

- › Simultaneously press the locking buttons on the fuse box cover and remove the cover.
- › Change the fuse.
- › Fit the cover and click into place.

ⓘ NOTICE

Danger of water entering the fuse box.

- ▶ Fit the cover correctly and click into place securely.

Fuses overview

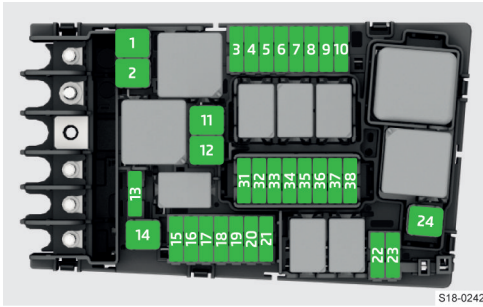

S18-0242

Fuse number	Consumer
1	ESC assist system, parking brake
2	Assistance system ESC
3	Engine control system
4	Engine components
5	Engine components
6	Brake sensor
7	Engine components
8	Lambda probe, NOx sensor
9	Engine components
10	Fuel pump
11	Electric auxiliary heater
12	Electric auxiliary heater
13	Oil pump for automatic gearbox
14	Heated windscreen
15	Horn
16	Ignition, fuel pump
17	ESC assist system, engine control unit, main relay coil
18	Data bus, 12 volt battery data module
19	Windscreen wiper
20	Alarm system
21	Automatic gearbox
22	Engine control system
23	Starter
24	Electric auxiliary heater
31	Not used
32	Not used
33	Not used
34	Not used
35	Not used
36	Not used
37	Auxiliary heating
38	Not used

Wheels

Tyres and rims

What you should be mindful of

ⓘ NOTICE

- ▶ Protect tyres from contact with lubricants and fuel.
- ▶ Always store wheels or tyres in a cool, dry and, where possible, dark place. Tyres without rims should be stored in an upright position.
- ▶ Alloy rims can be damaged by grit.
- ▶ Do not use light alloy rims with a high-shine surface in wintry weather conditions or with snow chains

Causes of uneven tyre wear

- ▶ Improper tyre pressure.
- ▶ Driving style (e.g. fast cornering, rapid acceleration and deceleration).
- ▶ Wheel alignment errors.
- ▶ Incorrect wheel balancing.

Wheel changes

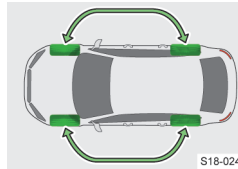

For uniform wear on all tyres, we recommend that you change the wheels every 10,000 km according to the schedule.

S18-0243

Advice for tyre assembly

- › With directional tires, the correct direction of rotation must be observed. The direction of rotation of the tyres is marked by arrows on the wall of the tyre.
- › Always replace the tyres by the axle.

Additional information

Only fit radial tyres of the same type, size (rolling circumference) and the same tread pattern on one axle.

Approved tyre sizes are specified in the technical vehicle documentation and in the declaration of conformity (in the so-called COC Document).

The declaration of conformity can be obtained from a ŠKODA Partner (valid for some countries and some models).

Tyres 245/40 R 19 94 W

A vehicle equipped with these tyres at the factory also has corresponding widening elements for the use of these tyres.

If you would like to have these tyres retrofitted, find out at a ŠKODA Partner about the possible retrofitting of your vehicle with the widening elements for the use of these tyres.

Overview of tyre labelling

Explanation of tyre markings

e.g. 215/55 R 17 94 V

- 215** Tyre width in mm
- 55** Height/width ratio in %
- R** Code letter for the type of tyre - Radial
- 17** Diameter of wheel in inches
- 94** Load index
- V** Speed symbol

Load index

The load index indicates the maximum permissible load for each individual tyre.

- 92** 630 kg
- 93** 650 kg
- 94** 670 kg
- 95** 690 kg
- 96** 710 kg
- 97** 730 kg
- 98** 750 kg
- 99** 775 kg

Speed symbol

The speed symbol indicates the maximum permissible speed for a vehicle fitted with tyres in the category concerned.

- S** 180 km/h
- T** 190 km/h
- U** 200 km/h
- H** 210 km/h
- V** 240 km/h
- W** 270 km/h
- Y** 300 km/h

⚠ WARNING

- ▶ Do not exceed the maximum permissible load and speed for the mounted tires.

Tread wear indicators



Wear indicators are located in the profile of the tyres that display the permissible minimum tread depth.

Markings on the walls of the tyres with the letters TWI or other symbols (e.g. Δ) indicate the position of the wear indicators.

A tyre is to be regarded as worn out when this wear indicator is flush with the tread.

i The tread depth can be measured with a tread depth gauge on the ice scraper. The ice scraper is located on the inside of the fuel filler flap.

⚠ WARNING

Risk of accident!

- ▶ Do not use worn tires.

Tyre manufacturing date

The date of manufacture is indicated on the tyre sidewall.

For example, DOT ... 10 20 means that the tyres were produced in the 10th week of the year 2020.

⚠ WARNING

Risk of an accident!

- ▶ Do not use tyres that are older than 6 years.

Troubleshooting

Help with a flat tyre

- ▶ Spare and emergency spare wheel » [page 212](#)
- ▶ Changing the wheel and raising the vehicle » [page 213](#)
- ▶ Breakdown kit » [page 214](#)

Change of tyre pressure



illuminates

- › Stop the vehicle.
- › Check the tyres and tyre pressures.

Show tyres with modified pressure

- › In the following menu, select the menu item for displaying the tyre condition:

CAR >

Or:

MENU > >

All-season or winter tires

Usage

All-season or winter tyres improve handling in winter weather conditions. They are characterised by 'M+S' and a mountaintop and snowflake symbol Δ .

What you should be mindful of

For the best possible handling, use tyres on all four wheels with a minimum tread depth of 4 mm.

Change winter tyres to summer tyres at the appropriate time. Summer tyres have better driving and braking characteristics on snow- and ice-free roads and at temperatures above 7 °C.

Usage conditions

If all-season or winter tyres are installed that have a lower speed category than the actual specified maximum vehicle speed, then proceed as follows:

- › In Infotainment, set the speed limit according to the category of tyres fitted.
- › In the driver's field of view, affix a warning label with the maximum value of the speed category intended for the tyres fitted (applies only to certain countries).

Settings

The speed limit setting for tyres is set in the Infotainment in the following menu item:

CAR >  >  > 

Or:

MENU >  >  >  > 

Snow chains

Usage

The snow chains improve driving in wintry road conditions.

⚠ WARNING

Risk of accident as well as tyre damage!

- ▶ Do not use chains on routes that are free from snow and ice.

What you should be mindful of

- › Before fitting the snow chains, remove the full wheel trims.
- › Only mount the snow chains on the front wheels.

Technical data

Permitted rim/tyre combinations for mounting of snow chains:

Rim size	Tyre size
6Jx16 ET43	215/60 R16

Only fit snow chains with links and locks that are no larger than 13 mm.

Spare and emergency spare wheel

Overview

Spare wheel

- ▶ The dimensions of a standard spare wheel correspond to the dimensions of the wheels mounted on the vehicle.
- ▶ A temporary spare wheel is provided with a warning label on the rim. This wheel is intended to enable you to reach the nearest specialist garage.

Inflate a space saver wheel with the maximum prescribed pressure.

Emergency wheel

A warning label is displayed on the rim of the temporary spare wheel. This wheel is intended to enable you to reach the nearest specialist garage.

An emergency wheel is significantly narrower than the wheels mounted ex-factory.

Remove the wheel on vehicles without sound system and replace

The spare wheel or emergency wheel is mounted in a recess under the floor covering or the variable loading floor in the boot.

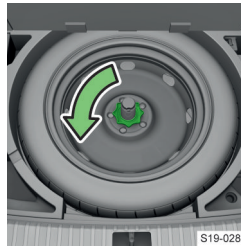

Removing

- › Remove the support foot for the boot floor.
- › Unscrew the lock nut.
- › Take out the wheel.

Inserting

- › Insert the wheel into the wheel well with the outside facing downwards.
- › Screw in the locknut until it stops.
- › Insert the support foot for the boot floor.

Remove the wheel on vehicles with sound system and replace

Removing

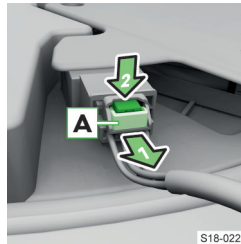

- › Partially pull out the safety tab **A**.
- › Press the safety button and remove the plug.

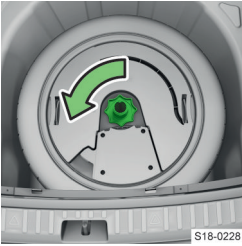

- › Unscrew the lock nut.
- › Remove the bass loudspeaker.
- › Take out the wheel.

Inserting

- › Insert the wheel into the wheel well with the outside facing downwards.
- › Insert the bass loudspeaker.
- › Screw in the locknut until it stops.
- › Insert the connector in the bass loudspeaker.
- › Secure the safety tab **A**.

Changing the wheel and raising the vehicle

What you should be mindful of

Before changing

- › Park the vehicle securely and secure it from rolling away.
- › Turn off the engine.
- › Let all of the occupants get out. During the wheel change they should not stand on the road, e.g. behind the crash barriers.
- › Close all doors, the boot and bonnet.
- › Uncouple any trailers.

Raise vehicle

⚠ WARNING

Always ensure the base plate of the lifting jack cannot slip!

- ▶ Provide a wide and firm base under the jack on loose surfaces.
- ▶ Create a non-slip base (e.g. a rubber floor mat) under the jack on a smooth surface.
- ▶ Always raise the vehicle with the doors closed.
- ▶ Do not insert any body parts under the raised vehicle.
- ▶ Do not start the engine of the lifted vehicle.

ⓘ NOTICE

Danger of damage to vehicle!

- ▶ Make sure that the jack is attached correctly to the bridge of the sill.

After having been changed

- › Check the tyre pressure on the mounted wheel and adjust if necessary.
- › In vehicles with a tyre indicator, save the tyre pressure values in the system.

- › Have the tightening torque of the wheel bolts of the mounted tyres checked with a torque wrench as soon as possible.

The specified tightening torque is 140 Nm.

Drive carefully until the tightening torque is checked.

Replace the damaged tyre. It is not recommended to repair the tyre.

⚠ WARNING

Risk of an accident!

- ▶ Too low a tightening torque may cause the wheel to disengage while driving.
- ▶ Too high a tightening torque can damage the threads and cause the rim to deform.

⚠ WARNING

Risk of an accident!

- ▶ Do not grease or lubricate screws.
- ▶ Do not use corroded or damaged screws.

Changing the wheel and raising the vehicle

Release screws

- › If the vehicle has covers over the wheel bolts or wheel trims, remove them.

⚠ WARNING

- ▶ If you step on the key end when loosening the screw, hold on to the vehicle for better stability.



Some vehicles may have anti-theft wheel bolts that protect the wheels from theft.

- › Insert the upper section on the anti-theft wheel bolt until it stops.



- › Place the key on the wheel bolt or on the attachment piece.
- › Turn the screw a maximum of half a turn so that the wheel does not come loose and fall off.

Jacking points for the jack

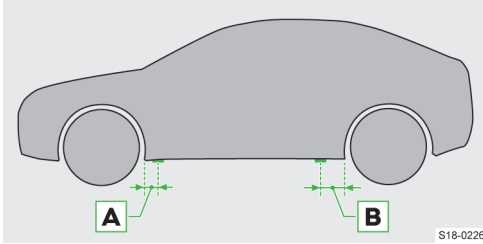

S18-0226

A 15 cm

B 27 cm

Position the jack and lift the vehicle

Use the jack from the tool kit.

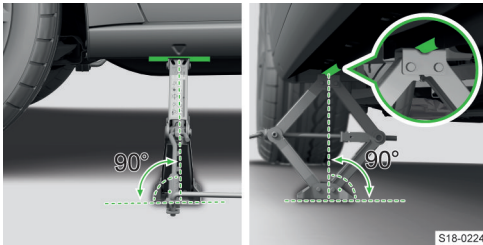

S18-0224

- › Position the jack at the jacking point closest to the wheel to be replaced.
- › Support the base plate of the jack with its full area resting on level ground and ensure that the jack is located in a vertical position at the jacking point.
- › Use the crank to raise the jack until its claw encloses the bar.
- › Continue to lift the vehicle until the wheel is just off the floor.

Changing a wheel

- › Unscrew the screws and place them on a clean surface.
- › Remove the wheel carefully.
- › Attach the wheel.
- › Slightly screw in the screws.
- › Lower the vehicle.

① NOTICE

- ▶ Applies to wheel trims supplied ex-factory or from ŠKODA Original Accessories: the anti-theft wheel bolt should be installed in the position marked on the back of the wheel trim.

Tighten screws

- › Tighten the opposite wheel bolts including the anti-theft wheel bolt one after the other.
- › Reinstall the cover caps of the wheel bolts or the full wheel covers.

I Keep the label with the code number of the anti-theft wheel bolts. A replacement upper section can

be acquired from ŠKODA original parts based on this.

Breakdown kit

Content overview

The kit is located in a box under the floor covering in the luggage compartment.

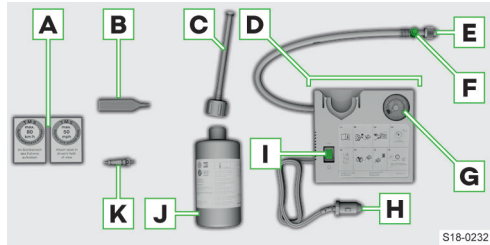

S18-0232

- A** Sticker with speed indication
- B** Valve remover
- C** Inflation hose with plug
- D** Air compressor (the layout of the controls may be different depending on the type of air compressor)
- E** Tyre inflation hose
- F** Button for pressure reduction
- G** Pressure indicator
- H** 12 volt cable connector
- I** ON and OFF switch
- J** Tyre inflation bottle
- K** Replacement valve core

The declaration of conformity is included with the air compressor or the log folder.

Usage conditions

Performing a repair with the breakdown kit not at all intended to replace a permanent repair on the tyre.

The purpose of the repair is to get you to the nearest specialist garage.

Change the tyre repaired by the breakdown kit as soon as possible.

Before using the kit

- › Park the vehicle securely and secure it from rolling away.
- › Turn off the engine.
- › Let all of the occupants get out. During the wheel repair they should not stand on the road, e.g. behind the crash barriers.

- › Close all doors as well as the bonnet and boot lid.
- › Uncouple any trailers.

After using the kit

If a tyre pressure of 2.0 bar cannot be achieved, the tyre is too damaged and cannot be sealed with the puncture set.

- › Stop driving. Seek the help of a specialist garage.

Once a tyre pressure of 2.0–2.5 bar is achieved, continue the journey at a maximum speed of 80 km/h (50 mph).

- › Avoid full accelerations, strong braking and fast cornering.

Information for driving with repaired tyres

- › The pressure of the repaired tyre must be checked after driving for 10 minutes.
- › If the tyre pressure is 1.3 bar and less, do not continue! Seek the help of a specialist garage.
- › If the tyre pressure is higher than 1.3 bar, correct the pressure to the correct value of at least 2 bar and continue driving.

ⓘ NOTICE

Danger of damage to the compressor!

- ▶ After the maximum running time of the air compressor, allow it to cool for a few minutes.

⚠ WARNING

Risk of burns!

The tyre inflation hose and the air compressor may become hot when inflated.

- ▶ Allow the air compressor and hose to cool for a few minutes.

Usage restrictions

Do not use the kit in the following cases:

- ▶ The rim is damaged.
- ▶ The outdoor temperature is below the minimum temperature indicated in the manual of the tyre filling bottle.
- ▶ Tyre punctures are greater than 4 mm.
- ▶ There is damage to the tyre wall.
- ▶ The expiry date stated on the tyre inflation bottle has expired.

Self-help

Seal the tyres

- › Unscrew the valve cap from the damaged tyre.
- › Unscrew the valve core with the valve insert and place it on a clean surface.
- › Shake the tyre inflation bottle back and forth with sealant.

- › Screw the inflation hose onto the tyre inflator bottle. The film on the closure is pierced automatically.
- › Remove the plug from the inflation hose and push it fully onto the tyre valve.
- › Hold the bottle with the bottom facing upwards and fill all of the sealing agent into the tyre.
- › Remove the filler plug from the valve.
- › Screw in the valve insert.

Inflate tyres

- › Fit the tyre inflation hose of the air compressor to the tyre valve.
- › Secure the vehicle with the parking brake.
- › Start the engine.
- › Plug the connector into the 12 volt socket.
- › Turn on the air compressor.
- › Once a tyre pressure of 2.0–2.5 bar is reached, turn off the air compressor.

Observe the maximum running time of the air compressor according to the directions of the repair kit manufacturer.

- › If an air pressure of 2.0 - 2.5 bar has not been reached, remove the tyre inflation hose from the valve.
- › Drive approx. 10 metres forwards or backwards to allow the sealing agent to distribute in the tyre.
- › Replace the tyre inflation hose on the valve and repeat the inflation procedure.

Tyre pressure

What you should be mindful of

ⓘ NOTICE

- ▶ Always adjust the tyre pressure to the load.
- ▶ Check the pressure in all tyres at least once a month and before each longer ride.
- ▶ Check the pressure when the tyres are cold. Do not reduce the higher pressure of warm tyres.
- ▶ After each change in tyre pressure, save the new values in the tyre control display.

⚠ WARNING

Risk of an accident!

- ▶ If tyre pressure loss is very quick, try to stop the vehicle carefully without heavy steering or heavy braking.

Sticker with prescribed tyre pressures

The sticker with prescribed tyre pressures is located on the inside of the fuel filler flap.

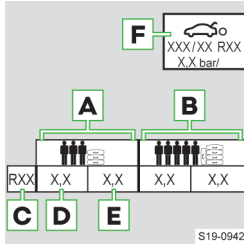

- A** Inflation pressure for half load
- B** Inflation pressure for a full load
- C** Tyre diameter in inches
This information only serves as information for the prescribed tyre pressure. This is not a listing of

approved tyre sizes for your vehicle. These are in the vehicle's technical documentation, as well as in the declaration of conformity (in the so-called COC document).

- D** Tyre pressure reading for the front axle tyres
- E** Tyre pressure reading for the rear axle tyres
- F** Prescribed tyre pressure value for the emergency wheel

Tyre pressure monitor

Functionality

The tyre pressure monitoring indicator indicates a change in tyre pressure.

Warning when pressure changes

 illuminates
 > Stop the vehicle.

- > Check the tyres and tyre pressures.

Function restriction

The system is unable to provide a warning in the event of a very rapid tyre pressure loss, e.g. sudden puncture.

The system function may be restricted in the following cases:

- > Uneven loading of the wheels, e.g. with a trailer attached
- > Sporty driving style
- > Driving on dirt roads
- > Snow chains fitted



Saving tyre pressure values



Store the tyre pressure values in the infotainment

- > Inflate the tyres to the prescribed inflation pressure.
- > Turn on the ignition.
- > In the following menu, select the menu item for displaying the vehicle condition:

CAR > 

Or:

MENU >  > 

- > Using the functional surfaces   select the tyre control display menu.
- > Tap on the functional surface  **SET**.
- > Then follow the instructions on the screen.

Save the tyre pressures in the following cases:

- > Change of tyre pressure
- > Change of one or more wheels
- > Change of position of a wheel on the vehicle
- > Always after covering a distance of 10,000 km or once a year

Troubleshooting

Tyre pressure display faulty

 flashes for about 1 minute and stays on

- > Stop the vehicle, switch off the ignition and start the engine.

If the symbol  flashes again after starting the engine, there is a system fault.

- > Continue driving, exercising appropriate caution, and seek the help of a specialist garage.

Wheel bolt cover caps

Remove cover caps and install

Disconnecting

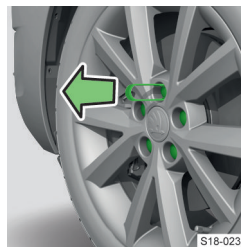

- > Push the pull-off clamp onto the cover cap up to the stop.
- > Remove the cover cap.

Installing

- > Push the cover cap onto the wheel bolt to the stop.

Full wheel frame

Removing and installing the trim

Applies to factory built or original accessory trims from ŠKODA.

Disconnecting

- > Hang the clamps for removing the wheel trims at the edge of one of the openings in the trim.

- › Push the wheel wrench through the clamp, support on the tyre and pull off the wheel trim.

Installing

- › Press the wheel trim onto the wheel rim at the designated valve opening.

When using an anti-theft wheel bolt, it must be located at the location indicated on the bezel.

- › Press the trim, starting at the valve, into the rim on both sides until it engages around the entire circumference.

ⓘ NOTICE

- › Use hand pressure, do not hit the wheel cover.

Removing and installing the Aero trim

Applies to factory built or original accessory trims from ŠKODA.

Removal

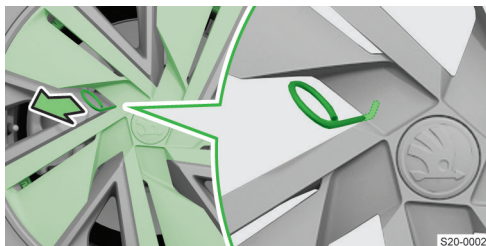

- › Hook the bracket as close to the centre as possible to remove the wheel covers at the edge of the panel.
- › Pull off the centre of the wheel cover by loosening it and pulling off the trim.

ⓘ To facilitate removal, it is possible to insert the wheel wrench through the bracket loop and pull on the two key ends.

Installing

- › When using an anti-theft wheel bolt, it must be located at the location indicated on the bezel.
- › Position the panel on the wheel rim and push in the individual spokes of the panel one after the other until they are fully engaged.
- › Press in the centre of the wheel cover until it engages completely.

ⓘ NOTICE

- › Use hand pressure, do not hit the wheel cover.

Storage space and interior equipment

Equipment in the boot

Overview

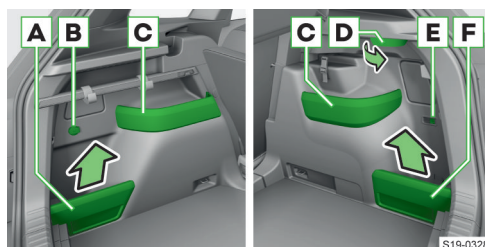

- A** Removable partition of the storage compartment
Max. load 2.5 kg
- B** 12-Volt-power socket
- C** Fixed storage compartment
Max. load 1.5 kg
- D** Lever for folding forward the rear seat backrests
- E** Trailer hitch switch
- F** Removable partition of the storage compartment
Max. load 2.5 kg

Emergency equipment

Overview

Emergency equipment in the luggage compartment

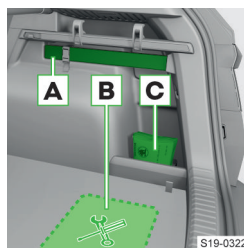

- A** Placing of the warning triangle
- B** Tool kit
- C** Placing of the first-aid kit

Storage compartment for the reflective vest

The storage compartment for the reflective vest is in the storage compartment of the front door.

Fire extinguisher under the passenger seat

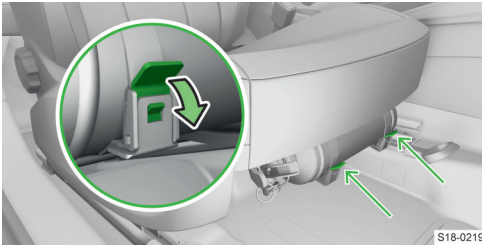

Tool kit

Overview

Depending on the equipment, not all of the following components may be included in the tool kit.

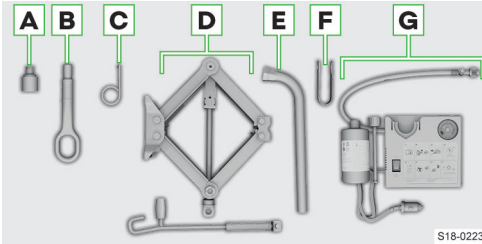

- A** Attachment for the anti-theft wheel bolts
- B** Towing lug
- C** Bracket for removing the full wheel covers
- D** Jack with sign and crank
- E** Wheel wrench
- F** Removal clip for the wheel bolt cover caps
- G** Breakdown set

The declaration of conformity is enclosed with the jack or the logbook folder.

Storage compartment for the reflective vest

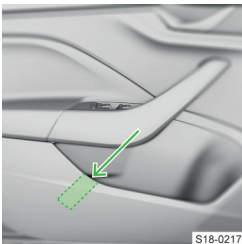

Fasteners in the boot

Overview

Vehicle without Varioflex seats

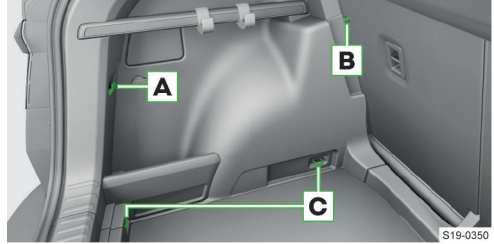

- A** Hook for securing the fastening nets
- B** Lashing eye for fastening the fastening nets
- C** Lashing eyes for securing the load and the fastening nets
Max. load 350 kg

Vehicle with Varioflex seats

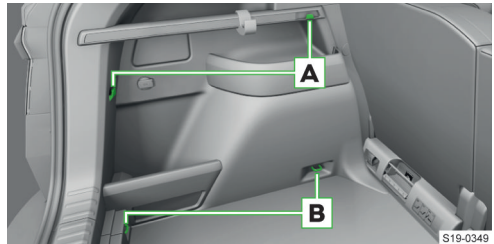

- A** Hook for securing the fastening nets
- B** Lashing eyes for securing the load and the fastening nets
Max. load 350 kg

Other fasteners

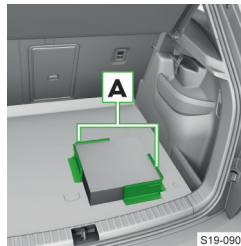

- A** Cargo elements
Max. load 8 kg
A storage compartment for the cargo elements is located under the floor covering in the boot.
› Fold up the cargo element and fasten it to the floor covering in the boot.

Bag hooks in the boot

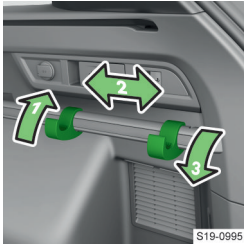

The maximum load for the hook is 5 kg.

The maximum load of the respective fastening nets is 1.5 kg.

Sliding hooks

Settings

Moving

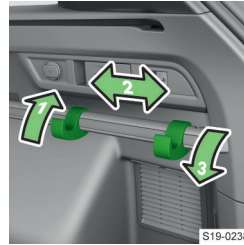

- 1 Loosening
- 2 Moving
- 3 Applying

Cargo elements in the luggage compartment

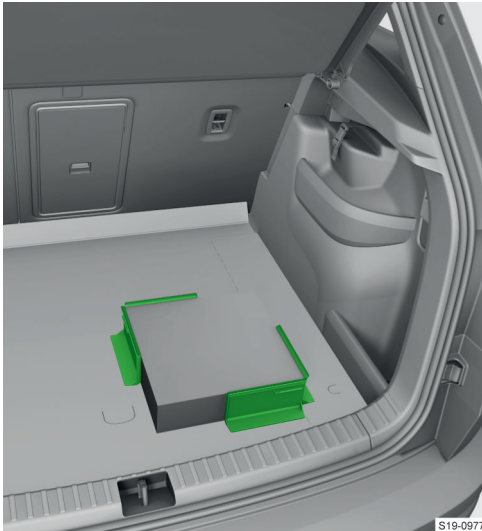

The maximum load for the Cargoelements is 8 kg.

Removal

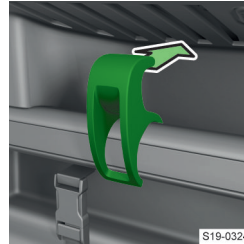

- › Press the hook until it is released and remove it.

Inserting hook

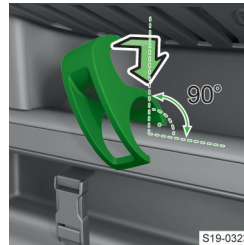

- › Place the hook in the direction of the slant on the fastening strip and straighten it.
- › Press the hook downwards and fold it down as far as possible.

Fastening nets

Overview

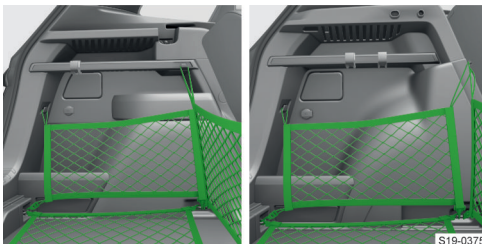

The maximum load for the hook is 5 kg.

Net partition

Attach the net partition

Attach at the back

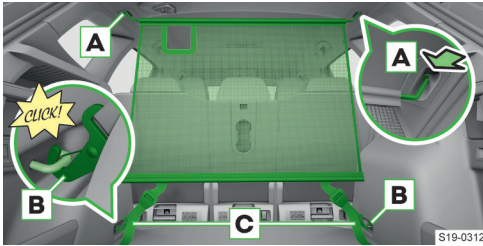

- › Insert the crossbar into the mount **A** on one side and push it forwards.
- › Fix the bar in the same way on the other side.
- › Snap the carabiners **B** into the lashing eyes.
- › Pull the straps firmly at the free ends **C**.

Fasten in the front

The procedure is analogous to the process behind. The lashing eyes for the carabiner are located under the central body pillars.

Loosening

Loosening takes place in the reverse order to fixing.

Double-sided floor covering

Overview

Depending on the equipment, the vehicle may be equipped with a double-sided floor covering in the luggage compartment. One side is made of fabric, the other side is washable.

Rigid boot cover

Removing and inserting

The maximum load of the other fastening nets is 1 kg.

Removing

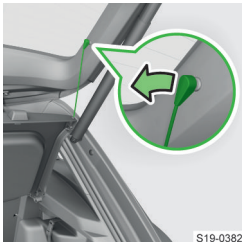

- › Unhook the straps.



- › Hold the raised cover in place and press the underside of the cover on both sides.
- › Remove the cover.

Inserting

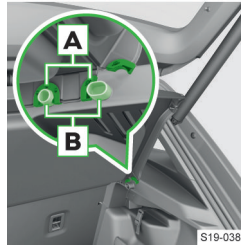

- › Insert the mount **A** opposite the holder **B** on both sides of the boot.
- › Press on the cover from above until it engages.
- › Hook in the retaining straps.

Store the cover behind the rear seats



- › Insert the cover behind the rear seats.

⚠ WARNING

The boot cover stowed behind the rear seats restricts the driver's rear view.

Roll-up luggage compartment cover

Operation

Pull out and roll up

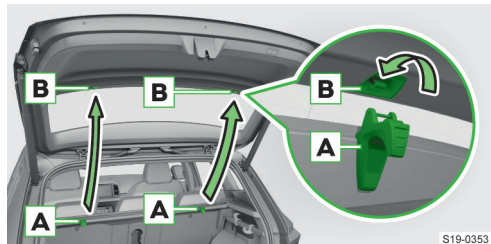

- › Hook the locking lugs **A** at the mounts **B**.
- › Roll it back takes place in reverse order. Hold the cover and let it roll up slowly.

Removing and inserting

Take out and insert the roll-up cover



- › Press the end of the crossbar and take out or insert the cover.

Variable loading floor in the boot

Setting the position

The maximum load of the variable loading floor is 75 kg.

Set the variable loading floor to the upper or lower position



- › Lift the variable load floor and pull it towards you.

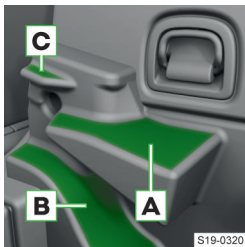

- › To set in the upper position, position the variable loading floor in the front area on area **A**.
- › To set in the lower position, position the variable loading floor in the front area in space **B**.
- › To form a connection to seats that have been

folded forwards, lay the variable loading floor in the front area on surface **C**.



- › Press the variable loading floor forward and hang up.

Park position

For instance, to reach the spare wheel more easily, the variable loading floor can be set to the parking position.

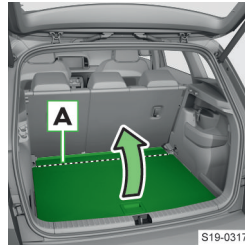

- › Set the variable loading floor to the upper position.
- › Lift the variable loading floor. The variable loading floor is folded up in area **A**.

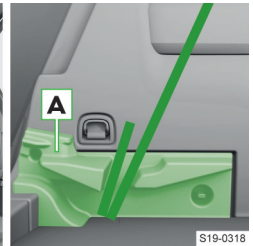
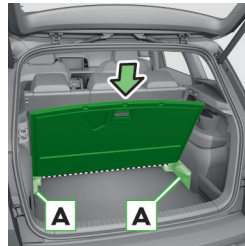

- › Push the variable loading floor that is folded up into the side panel **A**.

Through-loading bag

Insert and lock

Removable bag for seats with load-through device

In the bag, a max. of 4 pairs of skis with poles can be transported.

- › Fold the rear armrest and the cover in the seat backrest downwards.
- › Place the empty bag in the opening in such a way that the end of the bag with the zip is in the boot.
- › Place the skis with the tips facing to the front and the poles with the tips facing to the rear into the bag and close the bag.



- › Tighten the strap **A** around the skis in front of the bindings.
- › Partially fold the middle seat backrest forward.

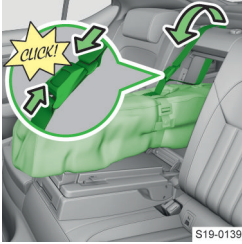

- › Guide the securing strap B through the opening around the upper part of the seat backrest.
- › Fold the seat backrests back until the locking button clicks into place.
- › Insert the securing strap into the lock until it clicks into place.

⚠ WARNING

The maximum weight of the transported skis is 17 kg.

ⓘ NOTICE

Risk of damage to the armrest!
 ▶ Handle the bag and the skis with care.

Removable bag for VarioFlex seats

Use the removable bag for VarioFlex rear seats.

In the bag, a max. of 2 pairs of skis with poles can be transported.

- › Fold the middle rear seat backrest forwards until it rests on the seat.
- › Place the empty bag in the opening in such a way that the end of the bag with the zip is in the boot.
- › Push the skis and poles with the tips backwards into the bag and secure the bag.
- › Pull the securing strap with both lock tongues out of the pocket of the bag.

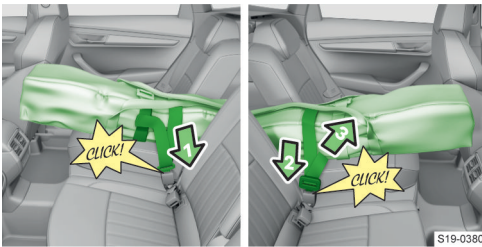

- › Tighten the drawstring around the skis on the tie base and at the free end.
- › Insert the locking tongues of the safety straps into the locks on the left and right sides of the middle seat until they audibly engage.
- › Move the securing strap between the foot and the tip of the binding and tighten at the free end.

⚠ WARNING

The maximum weight of the transported skis is 10 kg.

ⓘ NOTICE

Risk of damage to the armrest!
 ▶ Handle the bag and the skis with care.

Interior equipment front

Overview

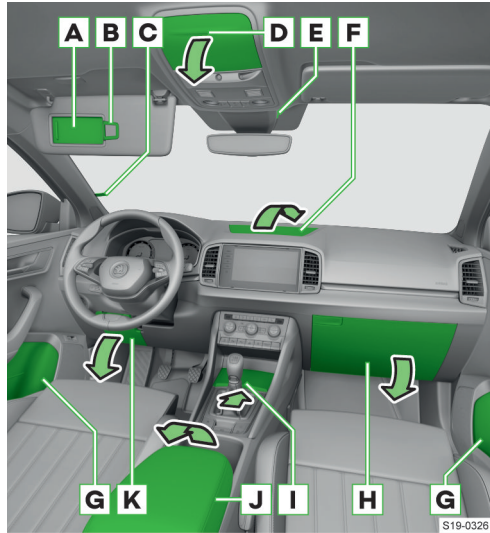

- A** Make up mirror
- B** Ticket holder
- C** Car park ticket holder
- D** Glasses compartment
 Max. load 0.25 kg
 › Press on the lid to open.
- E** USB connection
 The USB connection is for charging only.
- F** Storage tray
 › To open, press the button.
- G** Storage tray
 ▶ Bottle holder with a capacity of max. 1.5 l
 ▶ Storage compartment for the waste container
 ▶ Storage compartment for the reflective vest
 ▶ Rubber strip
- H** Storage compartment with air outlet nozzle
 In the compartment, there is a card holder, a pen holder and a storage compartment for coins.
 Max. load 3 kg
 › To open, press the button.
 › Turn the knob to position ☼ to open the air outlet nozzle.
- I** Storage tray

In the compartment is a 12-volt power outlet and a USB connection.

The USB connections can be used for charging and for data transfer.

- ▶ Pull the strip to open the compartment.

J Openable and adjustable armrest with storage compartment

- ▶ To open the compartment, lift the armrest.

K Storage tray

Max. load 0.5 kg

A card holder is located in the compartment.

- ▶ Pull on the handle to open.

NOTICE

- ▶ Do not leave any heat-sensitive objects in the spectacle compartment **D**.

Interior equipment rear

Overview

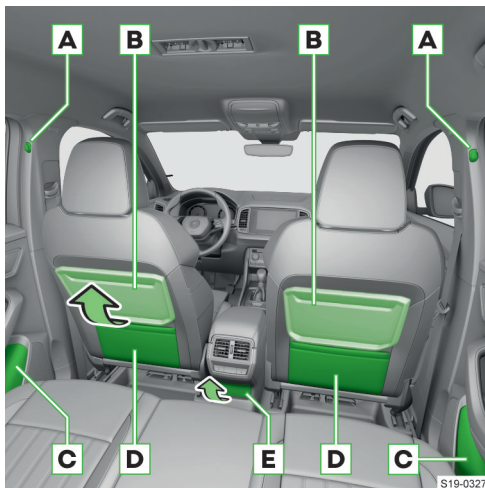

A Coat hook
Max. load 2 kg

B Folding table

C Storage tray
▶ Bottle holder with a capacity of max. 1.5 l
▶ Storage compartment for the reflective vest

D Storage pocket

E Depending upon vehicle equipment:

- ▶ 12 volt socket
- ▶ 230 volt socket

WARNING

- ▶ Only hang light clothing on the hooks. Do not leave heavy and sharp objects in the pockets of the clothing.
- ▶ Do not use hangers to hang clothes.

Car park ticket holder

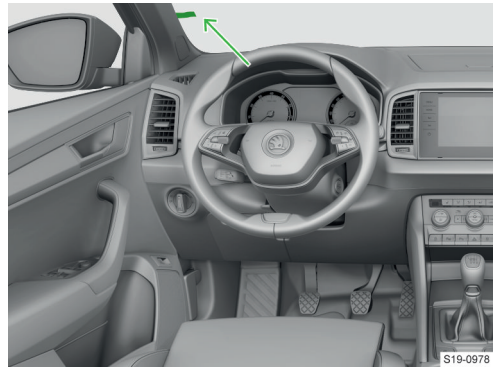

Rubber band in the door trim

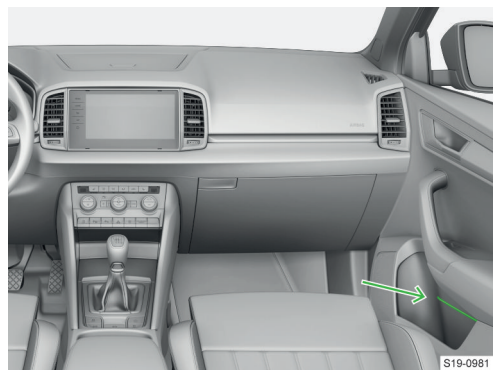

Bottle tray in the storage compartment of the front door



The tray is suitable for bottles with a max. size of 1.5 l.

Bottle tray in the storage compartment of the rear door



The tray is suitable for bottles with a max. size of 1.5 l.

USB-connections



The USB connection is for charging only.



The USB connections can be used for charging and for data transfer.



The USB connections are for charging only.

Hook on the centre body pillar



The maximum load for the hook is 2 kg.

⚠ WARNING

- ▶ Only hang light clothing on the hooks. Do not leave heavy and sharp objects in the pockets of the clothing.
- ▶ Do not use hangers to hang clothes.

Glasses compartment



The maximum load for the compartment is 0.25 kg.

① NOTICE

- ▶ Do not leave heat-sensitive objects behind in the glasses compartment.

Pen holder



Storage compartment for cards, coins and SD card



S19-0985

Storage compartment for cards in the storage area on the driver's side



S19-1058

Storage compartment for an umbrella

Overview

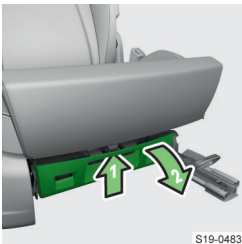

S19-0483

- › Pull on the handle to open.

Phonebox

What you should be mindful of

⚠ CAUTION

Risk of burns during charging.

- ▶ The phone may get warm, remove it carefully from the storage compartment.
- ▶ Do not leave any metal objects in the compartment under the phone. If there is a metallic object in the storage compartment, which has become hot, remove the phone and let it cool down in the storage compartment!

Functionality

Phonebox functions

- ▶ Wireless charging of phones.
- ▶ Amplification of the telephone signal (only valid for some countries).

The Phonebox is located in the storage compartment in the centre console at the front.

Insert a telephone with a maximum size of 160x80 mm into the storage compartment.

Charging Indicator

When the phone is charging, the Φ in the status bar in the infotainment screen will light up.

Recommendations for optimal function

- ▶ The phone is positioned with the screen facing up.
- ▶ Insert the phone without the protective case.
- ▶ Position the phone centrally on the phone symbol on the pad.

Operating conditions

Conditions for wireless charging

- ✓ The ignition is switched on.
- ✓ The phone supports the Qi standard.
- ✓ There is no object between the pad and the phone.

Troubleshooting

A message has been displayed on the Infotainment screen indicating that the mobile phone cannot be charged.

- ▶ Check that there is no object between the support and the phone to be charged. If this is the case, remove the phone and the item. Place the phone centrally on the phone symbol on the pad again.
- ▶ Check that the position of the phone to be charged has not changed. If this is the case, remove the phone and put it back in the centre of the phone symbol on the pad.

Cup holder

Overview

Cup holder at the front

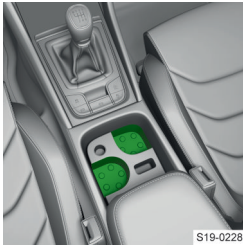

S19-0228

A bottle can be opened with one hand in the holder.

- ▶ Press the bottle into the holder and unscrew the cap.

Rear cup holder

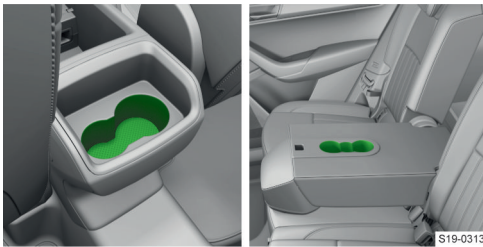

S19-0313

⚠ CAUTION
Risk of scalding!

- ▶ Never put hot beverage containers in the drinks holder.

ⓘ NOTICE
Danger of damage to the electrical system and the panels from spilled drinks.

Cup holder Easy Open

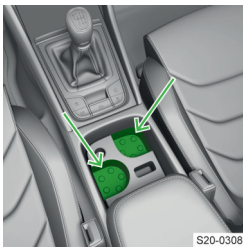

S20-0308

A bottle can be opened with one hand in the holder.

Waste container

Replace bags

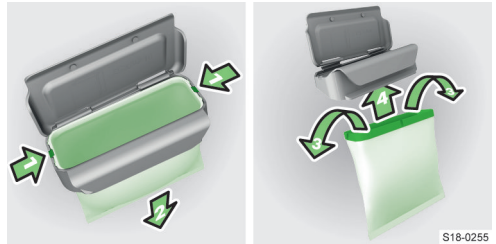

S18-0255

Ashtray and cigarette lighter

What you should be mindful of

- ⚠ CAUTION**
Risk of burning or fire!
▶ Do not use the ashtray for storing hot or burning objects.
- ▶ Handle the lighter carefully.

Operation

The ashtray is inserted in the cup holder.

Open the ashtray



S18-0264

Remove the lid



S18-0265

Cigarette lighter

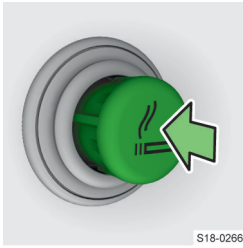

S18-0266

- › Push in the lighter.
- › Wait until the glowing lighter pops back out.
- › Remove the lighter and use.
- › Push the lighter back in.

The socket of the cigarette lighter serves as a 12-Volt socket.

Folding table

Operation

Fold up the table



S20-0250

- › Press the safety button and fold the table up to the desired position.

Unfold the table

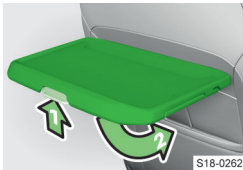

S18-0262

- › Press the safety button and unfold the table.

Slide out the cup holder

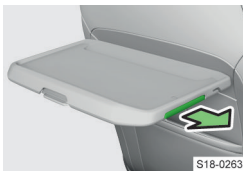

S18-0263

The maximum load for the table is 8.5 kg.

⚠ CAUTION

Risk of injury!

- ▶ While driving, the table must be in the folded-down position.

Multifunction holder

Overview

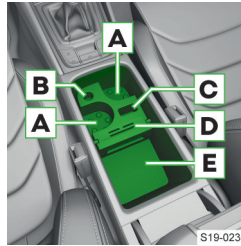

S19-0237

- A** Cup holder
- B** Storage compartment for storing the cover of the 12-volt power outlet
- C** Storage compartment for the vehicle key
- D** Storage compartment for coins and card
- E** Storage tray

card

- E** Storage tray

The multifunction holder can be removed or rotated.

Tablet holder

Settings

Tilt and turn



S18-0271

Adjust size

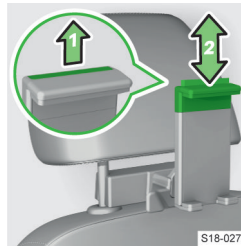

S18-0272

- › Pull out the locking tab and move the upper part of the holder to the desired position.

Set the minimum size of the empty holder to avoid noise while driving.

Removal and Insertion

Fasten behind the headrests

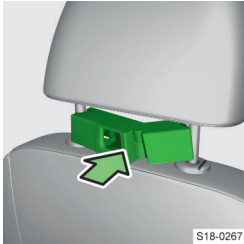

- › Place the open adapter on the front guide rods of the headrest and clip in carefully.

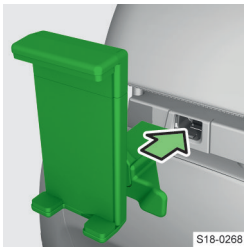

- › Clip in the holder in the adapter.

Removal

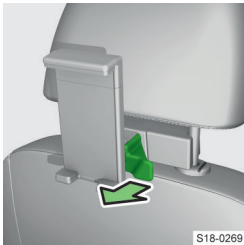

- › Press the safety button and unfold the holder.

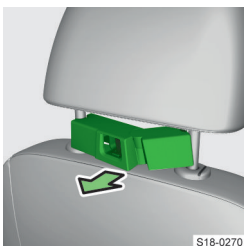

- › Press on the adapter and remove it.

Insert into the rear armrest



- › Clip the holder into the opening.

Removal



- › Press the safety button and unfold the holder.

Technical data

The holder is for fixing a tablet with a height of min. 11.5 cm and max. 19.5 cm.

The maximum load for the holder is 0.75 kg.

12-Volt power socket

Operating conditions

ⓘ NOTICE

Risk of damage to the electrical system of the vehicle!

- ▶ Use the sockets only for the connection of approved electrical accessories with a total power consumption of up to 120 watts.

ⓘ NOTICE

Danger of damage to the connected consumers!

- ▶ Switch off the consumers before switching the ignition on or off and before starting the engine.

230-Volt power socket

Functionality

ⓘ NOTICE

Danger of damage to the connected consumers!

- ▶ Do not connect a light with fluorescent lamp to the socket.
- ▶ Switch off the consumers before switching the ignition on or off and before starting the engine.

Status display

- ▶ Lit up in green - the socket is switched on.
- ▶ Blinking green - the socket is still switched on for about 10 minutes after the engine has been switched off, if a consumer was connected before the engine was switched off.

ⓘ The socket has a child safety lock. When inserting the plug, the fuse is unlocked and the socket is switched on.

Operating conditions

✓ Running engine

ⓘ On vehicles with the START-STOP system, the socket also works in STOP mode.

Troubleshooting

The indicator light flashes red

The socket is turned off e.g. for the following reasons:

- ▶ Excessive current
- ▶ Low state of charge of the 12-volt vehicle battery
- ▶ Overheating of the socket
- › If the reasons given above no longer exist and the socket is not switched on automatically, disconnect the connected load from the socket and reconnect after a short time.

230 volt socket and USB connections



The USB connections are for charging only.

Storage compartment with air outlet nozzle

Overview

In the compartment, there is a card holder and a pen holder.

The maximum load for the compartment is 3 kg.

- › Turn the knob in the compartment to position ✱ to open the air outlet nozzle.

Roof rack and hitch

Roof rack

Technical data

The maximum weight of the load incl. roof rack is 75 kg.

Swivelling hitch

What you should be mindful of

Applies to natural gas vehicles.

⚠ WARNING

An improperly installed or unsuitable tow hitch can damage the natural gas reservoir of the vehicle in an accident and thus deepen the consequences of the accident or cause fatal injuries.

- ▶ Due to the specific structure of the vehicles with natural gas reservoirs, we recommend using only the original ŠKODA tow hitch. With these accessories, ŠKODA stands for safety, reliability and suitability for this vehicle type.
- ▶ We recommend that all related assembly work be carried out by ŠKODA service partners.

⚠ WARNING

Risk of an accident!

- ▶ Do not manipulate the switch for swinging the tow bar in and out while a trailer or another accessory is coupled to the tow bar. The tow bar could be unlocked.

⚠ CAUTION

Risk of injury!

- ▶ Handle the trailer coupling carefully.
- ▶ When swinging out the tow bar, do not stand in the middle area of the rear bumper.

ⓘ NOTICE

Risk of damage to the trailer coupling!

- ▶ When not using the towing device, swing the tow bar under the bumper.

Tow bar: swivel out/in

Swing out the tow bar



- › Pull on the switch. The tow bar swings out. The indicator light → inside the switch illuminates.



- › Press the tow bar until it audibly clicks into place.

Check latching: the indicator light → within the switch lights up.

Swivel tow bar

① NOTICE

- ▶ No trailer or any other accessory can be connected to the tow bar.
- ▶ A socket or adapter may not be plugged into the socket.



- › Pull on the switch. The tow bar is unlocked. The indicator light → inside the switch illuminates.

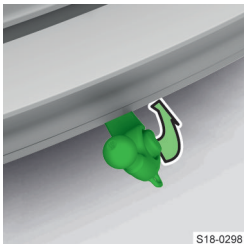

- › Swing in the tow bar under the bumper until it audibly clicks into place.

Check latching: the indicator light → within the switch lights up.

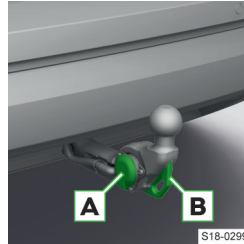

- › Plug the electrical trailer plug into the socket **A**.
- › Hook the tear-off rope of the trailer onto the safety eye **B**. The tear-off rope must sag against the vehicle in all trailer positions.

Uncoupling

Uncoupling takes place in reverse order.

Power supply of the trailer power network

In the electrical connection between the vehicle and trailer, the trailer is powered by the vehicle.

① NOTICE

Risk of damage to the vehicle electronics!
The total power consumption of all consumers connected to the trailer power supply must not exceed 350 watts.

Troubleshooting

Trailer coupling error

The indicator light → inside the switch does not light up or flash, or the tow bar does not lock into place.

- › Do not use the trailer coupling.
- › Seek the help of a specialist garage.

Tow bar not locked

- illuminates
- › Engage the tow bar.

Coupling or uncoupling a trailer or accessory

The following information describes the procedure for coupling and uncoupling a trailer. The information also refers to another accessory, e.g. a bike carrier.

⚠ WARNING

Risk of an accident!

- ▶ Do not use the safety eye for towing.
- ▶ Distribute and fix the load correctly.

i The trailer has a 13-pin electrical socket. If the trailer has a 7-pin connector, use a corresponding adapter from the ŠKODA Original Accessories.

Coupling

- › Swing out the tow bar.
- › Put the trailer drawbar onto the ball head.

Technical data

Tow hitch attachment points

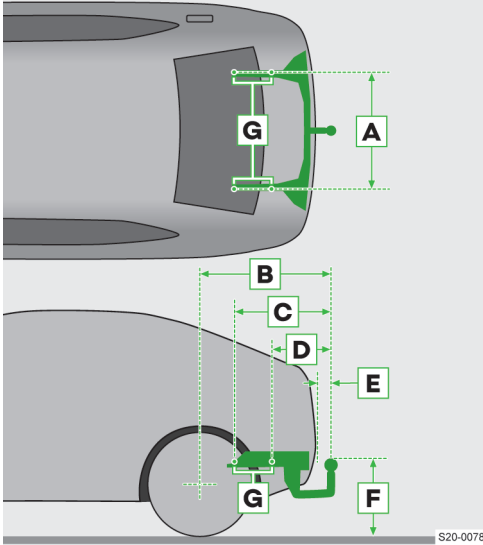

- A** Distance of the attachment points
- B** Length of the rear overhang to the centre of the ball head
- C** Distance of the front attachment point to the centre of the ball head
- D** Distance of the rear attachment point to the centre of the ball head
- E** Distance of the rear bumper to the centre of the ball head (according to the ECE-55 standard)
- F** Distance from the centre of the ball head to the road (according to the standard ECE-55)
- G** Fastening points on the body

In mm	
A	1047
B	958
C	633.6
D	413.6
E	min. 65
F	350-420

Maximum vertical load for trailer operation

The maximum vertical load for trailer operation depends on the engine type and the vehicle equipment.

The valid specification for your vehicle can be found in the technical vehicle documentation, (e.g. vehicle approval documentation, the COC document) or at a ŠKODA partner.

Other information (e.g. on the nameplate of the trailer device) merely provides information on the test values of the device.

Support load with mounted accessories

When using the accessories (e.g. bicycle carrier), the maximum length and the permissible total weight including load must be considered.

The maximum length of the mounted accessories (from the ball of the towing device) may not exceed 70 cm.

The permissible total weight of the mounted accessories including its load corresponds to the maximum vertical load for trailer operation; the value can be found in the vehicle registration documentation.

If the maximum load in trailer operation is more than 75 kg, then the permissible total weight of the mounted accessories including their load must not exceed 75 kg.

This value applies if the centre of gravity is at a distance of no more than 30 cm from the towing device ball head.

If the distance of the centre gravity of the load to the ball head of the towing device is greater than 30 cm, then the max. permissible total weight of the accessory, including its load, decreases (e.g. at a distance of 60 cm from the ball head, the permissible weight decreases by half).

If the distance between the centre of gravity of the load and the ball head of the towing hitch is 70 cm, the permissible total weight of the accessories including their load is reduced to 0 kg.

⚠ WARNING

Risk of an accident!

- ▶ Do not exceed the maximum vertical load.
- ▶ The permissible trailer load and the weight of another accessory, e.g. of the bike carrier, is not to be exceeded.

ⓘ NOTICE

Risk of damage to the trailer and the vehicle itself!

- ▶ When using the accessory (e.g. bicycle carrier), observe the maximum length and the permissible total weight of the accessory incl.

Maintaining and cleaning

Service events

service intervals

Compliance with service intervals is crucial for the life and value of the vehicle.

You will be notified of the due date for service with the symbol  and the corresponding message on the display of the instrument cluster.

The specialist garage will inform you of the type of service interval, the option of changing this and the scope of service.

I All services and the replacement or refilling of operating fluids are chargeable to the customer, even during the warranty period, unless the ŠKODA AUTO warranty conditions or other binding agreements determine otherwise.

Proof of service

A specialist garage stores the proof of service in the information system called Digital Service Plan.

The proof of service can be printed out.

Displaying the service due date in the Infotainment system

► In Infotainment, select the following menu:

CAR >  > Menu item for the Service

Or:

MENU >  > Menu item for the Service

Resetting information

We recommend that you do not reset the information regarding service events on your own. It can lead to incorrect setting of the service intervals and thus also to possible faults in the vehicle.

For vehicles with a variable service interval, new service interval values calculated according to the previous operating conditions will be displayed after the oil change service indicator is reset. These values will then continue to be adjusted according to the current operating conditions.

Service work, adjustments and technical changes

The instructions and guidelines from ŠKODA AUTO must be observed when carrying out any modifications, repairs or technical alterations to the vehicle.

Adhering to these instructions and guidelines helps ensure road safety and helps keep the vehicle in a good technical condition.

We advise only using ŠKODA Original Accessories and ŠKODA Original Parts which have been expressly approved for use on your vehicle. Reliability, safety

and suitability for your vehicle are guaranteed with these.

ŠKODA Service partner

All ŠKODA service partners work according to the instructions and guidelines from ŠKODA AUTO. Service and repair work is therefore carried out on time and at the appropriate quality. Adhering to these instructions and guidelines helps ensure road safety and helps keep the vehicle in a good technical condition.

We therefore advise having all modifications, repairs and technical alterations to the vehicle carried out by a ŠKODA Service Partner.

ŠKODA original parts

We recommend the use of ŠKODA Genuine Parts for your vehicle, as these parts are approved by ŠKODA AUTO. These parts comply wholly with ŠKODA AUTO regulations and are identical to the parts used in series production.

ŠKODA AUTO is able to warrant the safety, suitability, and long life of these products.

ŠKODA Service Partners are liable for any defects of ŠKODA Genuine Parts for a period of 2 years after sale in accordance with the materials defect liability, unless agreed otherwise in the purchase agreement.

ŠKODA original accessories

We recommend that you use ŠKODA Genuine Accessories in your vehicle. With these accessories, ŠKODA AUTO stands for safety, reliability and the suitability for your vehicle type.

ŠKODA Service Partners are liable for any defects of ŠKODA Genuine Accessories for a period of 2 years after installation or delivery in accordance with the materials defect liability, unless agreed otherwise in the purchase agreement or any other agreements.

Spoiler

WARNING

Risk of an accident!

- Only use the original spoiler on the front bumper in combination with the original spoiler on the boot lid.
- The original spoiler on the front bumper cannot be left on its own without the spoiler on the luggage compartment lid or in combination with an unsuitable spoiler on the luggage compartment lid.
- We recommend that you consult the ŠKODA Service Partner for any repairs to or replacement, addition or removal of spoilers.

Component protection

Some electronic vehicle components (such as the instrument cluster) are factory-equipped with component protection. This component protection ensures the functional limitation of these components in a

non-legitimate installation in another vehicle (e.g. after a theft) or operation outside the vehicle.

Interior

What you should be mindful of

① NOTICE

- ▶ Use cleaning agents intended for cleaning and care of the individual materials.
- ▶ Do not use aggressive cleaning agents or chemical solvents.

Natural leather / Faux leather / Alcantara® / Suedia / material

① NOTICE

- ▶ Remove impurities as soon as possible.
- ▶ Do not use solvents, floor wax, shoe cream, stain remover or similar agents on Alcantara® and Suedia suede seat upholstery.
- ▶ Make sure that natural leather is not moistened when cleaning and that no water seeps into the seams.
- ▶ Do not clean the roof cladding with a brush.

① NOTICE

Risk of fading to the cover fabric!

- ▶ If necessary, do not leave the covers for long periods in the blazing sun.

ⓘ

- ▶ During use, the leather and Alcantara®- and Suedia and materials may show minor changes (e.g. folds or discolouration). This does not constitute a material defect.
- ▶ Some clothing fabrics, e.g. dark denim, sometimes do not have sufficient colour fastness. As a result, discolouration that is clearly visible on the seat upholstery can occur. This is not a defect in the fabric.
- ▶ Sharp-edged zippers, rivets, clamps and similar garments can damage the upholstery in the vehicle. Such damages cannot be subsequently recognised as a justified complaint.

Plastic parts

① NOTICE

Risk of damaging the dash panel!

- ▶ Do not attach fragrances and air fresheners to the dash panel.

Windows

① NOTICE

Risk of damage to the filaments or the glass antenna!

- ▶ Do not stick stickers on the heating filaments.

- ▶ Do not use sharp objects (such as pot scrapers, etc.) to clean the windows.

Covers on electrically heated seats

① NOTICE

Risk of damaging the heating system!

- ▶ Do not clean the seats with water or other liquids.
- ▶ Do not dry the seats by switching on the heating.

Seat belts

① NOTICE

Risk of damage to the seat belts!

- ▶ Do not dry clean the seat belts.
- ▶ Allow cleaned belts to dry before rolling up.

Instructions for cleaning

Natural leather / Faux leather / Alcantara® / Suedia / material

- › Remove dust and dirt on the surface with a vacuum cleaner.
- › Remove fresh impurities with water, slightly moistened cotton cloth or woollen cloth; if necessary, use a mild soap solution¹⁾ and wipe with a dry cloth.
- › Remove stubborn stains with a suitable cleaning agent.
- › For regular care of natural leather, use the equipment provided for this purpose. After each clean, use a care cream with light protection and impregnation effect.
- › When looking after Alcantara®, Suedia and fabric surfaces, remove stubborn hair with a cleaning brush. Remove pills from materials with a brush.

Plastic parts

- › Remove impurities with water, slightly moistened cloth or sponge with a suitable cleaning agent if necessary.

Windows

- › Remove impurities with clean water and dry with a cloth provided for this purpose.

Infotainment screen

- › Remove any impurities on the screen using the cleaning agents provided.

① NOTICE

Danger of screen damage!

- ▶ When removing dirt, do not press on the screen.

Covers on electrically heated seats

- › Remove impurities with a suitable cleaning agent.

¹⁾ A mild soap solution consisting of 2 tablespoons of white neutral soap to 1 litre of lukewarm water.

Seat belts

- › Remove impurities with a soft cloth and mild soap solution.¹⁾

Exterior**What you should be mindful of****⚠ WARNING**

Risk of accident!

After washing the vehicle, the functionality of the brake system may be affected by moisture and, in winter, by ice.

- ▶ Dry and clean the brakes by braking several times.

ⓘ NOTICE

- ▶ Bird droppings, insect residues, litter and sea salt residues, overflowed fuel, AdBlue® etc. are to be removed as soon as possible.

- ▶ Do not use rough sponges, scourers or similar to remove dirt.

- ▶ Use cleaning agents intended for cleaning and care of the individual materials.

- ▶ Do not use aggressive cleaning agents or chemical solvents.

- ▶ Do not polish the vehicle in a dusty environment.

ⓘ NOTICE

AdBlue® picks up some materials, e.g. paint and plastics.

- ▶ Clean the affected area with a damp cloth and cold water.

- ▶ Remove any dried solution with warm water and a sponge.

ⓘ NOTICE

- ▶ Paint damage should be repaired as soon as possible.

- ▶ Do not treat matt lacquered parts with polish or hard wax.

- ▶ Do not polish foils.

- ▶ We recommend treating door seals and window guides with the appropriate tools from ŠKODA original accessories. These ensure that the protective lacquer layer of the seals and window guides is not attacked.

- ▶ Do not use abrasive cleaning agents to clean the rear view camera.

Before driving through a car wash

- › Observe the usual specifications of the car wash, e.g. close all windows, fold the mirrors, etc.
- › Move the windscreen wiper lever to position **OFF** to adjust.

- › If there are special attachments on your vehicle, observe the instructions of the car wash operator.

ⓘ NOTICE

- ▶ Deactivate the Auto Hold function if it is necessary to roll the vehicle when passing through a car wash.

ⓘ NOTICE

In vehicles with an electric luggage compartment lid, this can open automatically due to the pressure of the washing brushes.

- ▶ Lock the vehicle, e.g. with the central lock button.

After washing with a wax preservation

- › Wipe off the windscreen wiper blades with a dry cloth.

Wash with a pressure washer**ⓘ NOTICE**

- ▶ Follow the operating instructions for the high-pressure cleaner, in particular the instructions relating to the pressure and the spray distance to the vehicle surface.

- ▶ Do not direct the water jet directly at the following vehicle parts

- ▶ Films
- ▶ Lock cylinder
- ▶ Columns on the vehicle
- ▶ Trailer connection
- ▶ Swivelling ball bar
- ▶ Camera lenses and sensors
- ▶ Plastic, chromed and anodised parts

Remove snow and ice**ⓘ NOTICE**

- ▶ Remove snow and ice with a plastic scraper or a suitable deicing agent.

- ▶ Clean the cameras with a hand brush.

- ▶ Only move the scraper in one direction.

- ▶ Do not use scratchers or other sharp objects for foils.

- ▶ Do not remove snow and ice with hot or warm water.

- ▶ Do not remove snow and ice from surfaces with coarse dirt.

Instructions for cleaning**Handwash**

- › Wash the vehicle from top to bottom with a soft sponge or wash glove and plenty of water, if necessary with additional suitable cleaning agents.

¹⁾ A mild soap solution consisting of 2 tablespoons of white neutral soap to 1 litre of lukewarm water.

236 Maintaining and cleaning › Ice scraper

- › For foils and headlights, use a mild soap solution that contains two tablespoons of white neutral soap to one litre of lukewarm water.
- › Use a glass cleaner for the windscreen wiper blades.
- › Wash the cameras with clean water and dry with a suitable clean wipe.

① NOTICE

- ▶ Wash out the sponge or wash mitt regularly.
- ▶ Use a different sponge for wheels, sills and the lower part of the vehicle than that used for the other vehicle parts.
- ▶ Do not wash the vehicle in the blazing sun.
- ▶ Do not dry the headlights or use sharp objects.
- ▶ Do not put pressure on the bodywork when washing.
- ▶ The temperature of the washing water may be a max. 60 °C.

After hand washing

- › Rinse the vehicle and wipe it with a suitable clean cloth.

Vehicle paint

- › Preserve the varnish at least twice a year with hard wax.
- › Use a polish for matt lacquers.

Films

Films will age and become brittle – this is entirely normal: this is not an error.

The following factors have a negative effect on the life or colour fastness of the films:

- ▶ Sun rays
- ▶ moisture
- ▶ Air pollution
- ▶ Stones, e.g. due to the rebound of the cargo during transport on the roof rack

Protection of hollow spaces

Corrosion-prone cavities of the vehicle are permanently protected by preservative wax at the factory.

- › Remove spilled wax with a plastic scraper, clean stains with mineral spirits.

Underseal

The underside is permanently protected by the factory against chemical and mechanical influences.

- › Have the protective coating checked by a specialist garage before starting and at the end of the cold season.

Wheels

- › After washing, preserve the wheels with suitable means.

⚠ WARNING

Risk of an accident!

- ▶ Severe dirt on the wheels can result in the wheels unbalancing.

Car jack

- › If necessary, treat moving parts with suitable grease.

Tow hitch

- › Coat the ball head of the towing device with a suitable grease whenever necessary.

Ice scraper

On the fuel filler flap

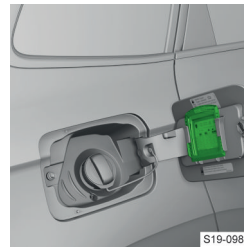

Technical data and specifications

Requirements for the technical data

The emission standard, information on fuel consumption and other information pertaining to your vehicle can be found listed in the technical vehicle documentation and in the declaration of conformity (in the so-called COC Document).

The information listed was determined in accordance with rules and under conditions that are stipulated by legal or technical regulations.

This and other information about your vehicle and the declaration of conformity can be obtained from a ŠKODA Partner.

The details in the technical vehicle documentation and in the declaration of conformity take precedence over the information in this Owner's Manual. These specifications and values apply to your vehicle in its condition and configuration at the time of delivery from the manufacturer. Retrofitting an accessory can have a negative impact on this information and values, in particular the values regarding fuel consumption and carbon dioxide (CO₂), which are specified in the vehicle documentation and in the declaration of conformity.

The performance values listed were determined without performance-reducing equipment, e.g. air conditioning system.

Vehicle identification data

Vehicle identification number (VIN)

The vehicle identification number is found at the following locations:

- ▶ Directly in the engine compartment on the suspension turret
- ▶ On a plate under the windscreen in the lower left corner
- ▶ On the type plate at the bottom of the middle body pillar of the vehicle



Type plate

- A** Vehicle manufacturers
- B** Vehicle identification number (VIN)

VIN display

The display of the VIN takes place in the infotainment in the following menu item:

CAR > > Menu item for the Service

Or:

MENU > > > Menu item for the Service

Engine number

The engine number is embossed on the engine block.

Maximum permissible weights

The maximum permissible weights are listed on the nameplate.

The type plate is located at the bottom of the middle body pillar of the vehicle.

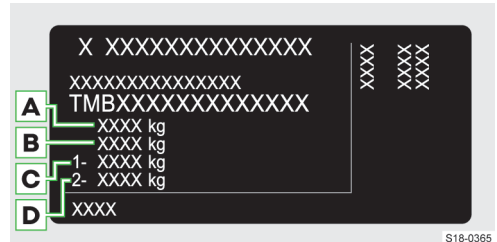

- A** Maximum permissible gross weight
- B** Maximum permissible towed weight (towing vehicle and trailer)
- C** Maximum permissible front axle load
- D** Maximum permissible rear axle load

Maximum permissible towed weight

The specified value is valid for altitudes up to 1000 m above sea level.

The engine output falls as the height increases, as does the ability to climb.

Therefore, for every additional 1,000 m in height (or part), the maximum permissible towed weight must be reduced by 10 %.

The towed weight is made up of the actual weights of the loaded towing vehicle and the loaded trailer.

Payloads

It is possible to calculate the approximate maximum payload from the difference between the permissible total weight and the operating weight.

The payload consists of the following components:

- ▶ The weight of the passenger
- ▶ The weight of all luggage and other loads
- ▶ The weight of the roof, including the roof rack system

- ▶ The weight of the equipment that is excluded from the operating weight
- ▶ Trailer bearing load for trailer towing » page 232

⚠ WARNING

Risk of accident and danger of vehicle damage!

- ▶ Do not exceed the specified values for the maximum permissible weights.

Operating weight

Information about the operating weight

The specification corresponds to the lowest possible operating weight without additional weight-increasing equipment. This includes 75 kg driver's weight, the weight of the operating fluids and the on-board tool kit and a fuel tank filled to min. 90%.

Operating weight

Engine type	Gearbox	Operating weight (kg)
1.0 l/81 kW TSI	Manual gearbox	1340
1.4 l/110 kW TSI	Automatic gearbox	1390
	DSG ^{a)} 4x4	1505
1.5 l/110 kW TSI	Manual gearbox	1380
	DSG ^{a)}	1387
2.0 l/140 kW TSI	DSG ^{a)} 4x4	1551/1555 ^{b)}
1.6 l/81 kW MPI	Manual gearbox	1325
	Automatic gearbox	1345
2.0 l/85 kW TDI CR	Manual gearbox	1458
	DSG ^{a)}	1465
2.0 l/105 kW TDI CR	DSG ^{a)}	1457
2.0 l/110 kW TDI CR	Manual gearbox	1459
	DSG ^{a)} 4x4	1586

^{a)} Automatic dual-clutch transmission.
^{b)} Applies to cars with the EU6DG emission standard.

i Ask for the exact vehicle weight in a specialist garage.

Vehicle dimensions

Dimensions

Specification	Value (in mm)	
Vehicle height	1603/1607 ^{a)}	
Vehicle width with folded-in mirrors	1841	
Vehicle width with folded-out mirrors	2025	
Ground clearance of the vehicle	Basic dimensions	172/167 ^{a)}
	Vehicles with 1.0 l/81 kW TSI engine	163
	Vehicles with 1.4 l/110 kW TSI and 1.6 l/81 kW MPI engine	171/176 ^{a)}
Vehicle length	4382/4398 ^{b)}	

^{a)} Applies to Karoq 4x4.
^{b)} Applies to vehicles Karoq Scout.

Engine specifications

1.0 I/81 kW TSI engine

Output (kW at rpm)	81/5500
Highest torque (Nm at rpm)	200/2000-3000
Number of cylinders/displacement (cm ³)	3/999
Gearbox	Manual gearbox
Maximum speed (km/h)	187
With specified gear engaged	5
Acceleration 0-100 km/h (s)	11.1

1.4 I/110 kW TSI engine

Number of cylinders/displacement (cm ³)	4/1395		
Gearbox	Automatic gearbox	6-Speed DSG ^{a)} 4x4	7-Speed DSG ^{a)} 4x4
Output (kW at rpm)	110/5000	110/5000-6000	110/5000
Highest torque (Nm at rpm)	250/1500-4000	250/1500-3500	250/1500-4000
Maximum speed (km/h)	199	192	194
With specified gear engaged	6	5	5
Acceleration 0-100 km/h (s)	8.8	9.0	8.8
^{a)} Automatic dual-clutch transmission.			

1.5 I/110 kW TSI engine

Output (kW at rpm)	110/5000-6000	
Highest torque (Nm at rpm)	250/1500-3500	
Number of cylinders/displacement (cm ³)	4/1498	
Gearbox	Manual gearbox	DSG ^{a)}
Maximum speed (km/h)	207	206
With specified gear engaged	5	5
Acceleration 0-100 km/h (s)	8.9	9.0
^{a)} Automatic dual-clutch transmission.		

2.0 I/140 kW TSI engine

Output (kW at rpm)	140/4200-6000
Highest torque (Nm at rpm)	320/1500-4100
Number of cylinders/displacement (cm ³)	4/1984
Gearbox	DSG ^{a)} 4x4
Maximum speed (km/h)	217
With specified gear engaged	5 ^{b)} /6
Acceleration 0-100 km/h (s)	6.9
^{a)} Automatic dual-clutch transmission.	
^{b)} Applies to cars with the EU6DG emission standard.	

1.6 I/81 kW MPI engine

Output (kW at rpm)	81/5800	
Highest torque (Nm at rpm)	155/3800-4000	
Number of cylinders/displacement (cm ³)	4/1598	
Gearbox	Manual gearbox	Automatic gearbox
Maximum speed (km/h)	182	178
With specified gear engaged	5	5
Acceleration 0-100 km/h (s)	11.2	12.7

2.0 I/85 kW TDI CR engine

Number of cylinders/displacement (cm ³)	4/1968	
Gearbox	Manual gearbox	DSG ^{a)}
Output (kW at rpm)	85/2750-4250	85/3250-4250
Highest torque (Nm at rpm)	300/1600-2500	250/1500-3250
Maximum speed (km/h)	190	189
With specified gear engaged	5	6
Acceleration 0-100 km/h (s)	10.6	11.0
^{a)} Automatic dual-clutch transmission.		

2.0 I/105 kW TDI CR engine

Output (kW at rpm)	105/3500-4000	
Highest torque (Nm at rpm)	320/1750-3000	
Number of cylinders/displacement (cm ³)	4/1968	
Gearbox	DSG ^{a)}	
Maximum speed (km/h)	196	
With specified gear engaged	5	
Acceleration 0-100 km/h (s)	9.6	
^{a)} Automatic dual-clutch transmission.		

2.0 I/110 kW TDI CR engine

Number of cylinders/displacement (cm ³)	4/1968	
Gearbox	Manual gearbox	DSG ^{a)} 4x4
Output (kW at rpm)	110/3250-4200	110/3000-4200
Highest torque (Nm at rpm)	340/1600-3000	360/1600-2750
Maximum speed (km/h)	207	199
With specified gear engaged	6	6
Acceleration 0-100 km/h (s)	8.8	8.7
^{a)} Automatic dual-clutch transmission.		

Accident data recorder (Event Data Recorder)

The vehicle is equipped with an accident data recorder, hereinafter called as "EDR". The purpose of

the EDR lies in the data recording during a traffic accident or another extraordinary traffic situation, hereinafter called as "accident".

Data is only recorded in the event of an accident in which the restraint systems are triggered.

The EDR records the accident in a short time (approximately 10 s), by showing the following information, for example:

- ▶ The function of certain systems in the vehicle.
- ▶ The seat belt status of the driver and front passenger.
- ▶ The actuation of the brake and accelerator pedals.
- ▶ The speed of the vehicle at the time of the accident.

The recorded data support the analysis of how the vehicle systems behaved shortly before, during and shortly after the accident. This enables them to clarify the circumstances of the accident.

The data relating to assist systems in the vehicle is also recorded. Whether for instance the affected systems were switched on or off at the corresponding time, whether they were only partially available or were inactive. There is also the possibility of tracking whether these vehicle functions controlled, accelerated or decelerated the vehicle during the accident. Depending on the equipment, these functions are, e.g:

- ▶ Adaptive Cruise Control (ACC).
- ▶ Lane Assist (Lane Assist).
- ▶ Park Assist.
- ▶ Emergency braking function (Front Assist).

Under normal driving conditions, data is not recorded. There is no audio or video recording from the vehicle interior or surroundings. Personal data such as name, gender, age or place where the accident occurred is not stored in the EDR. However, third parties such as law enforcement authorities may use certain resources to connect EDR content to other data sources, and therefore deduce the identification of some of the people involved in the accident when investigating the causes of the accident.

For reading the EDR-Data, special equipment is required and the ignition switched on.

ŠKODA AUTO will not read or otherwise process any accident data from the EDR without the approval of the vehicle owner or other person authorised for use of the vehicle. Exceptions are specified in the contractual arrangements, or these are subject to generally binding regulations.

Due to legal requirements, ŠKODA AUTO is required to monitor the quality and safety of its products, meaning that it is only entitled to use data from the EDR to monitor the product on the market, for further research and development, and to improve the quality of the vehicle's safety systems. For the purpose of research and development, ŠKODA AUTO will also make data available to third parties. This is done exclusively in anonymous form, i.e. without any connection to the specific vehicle, the vehicle owner or any other authorised user.

Personal data

Personal customer data is collected, processed and used by ŠKODA AUTO in accordance with the provisions of the generally binding legal provisions in the area of personal data protection.

The current declaration on the protection of personal data is displayed using the following link or by reading the QR code:

<https://www.skoda-auto.com/other/personal-data>



Information about the radio systems in the vehicle

Your vehicle has various radio systems.

Manufacturers of this radio equipment declare that this equipment complies with the requirements of **Directive 2014/53 / EU** and the **Technical Regulation on Radio Equipment, approved by the Decision of the Cabinet of Ministers of Ukraine of 25 May 2017 no. 355**.

Information about **Directive 2014/53 / EU** on the approximation of the laws of the Member States relating to the marketing of radio equipment, **Technical regulation on radio equipment, approved by the decision of the Cabinet of Ministers of Ukraine of May 25, 2017 No. 355** as well as regarding **declaration of conformity**, can be viewed on ŠKODA web pages using the following link or by scanning the QR-code:

<https://www.skoda-auto.com/services/red-doc>



After this, proceed as follows:

1. Select the desired region.
2. Select Download Declaration of conformity against the desired model, to receive the certificates.

Examples of labelling of radio systems

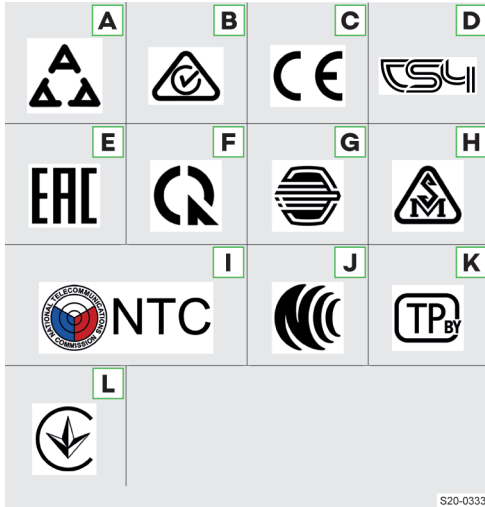

- A** Serbia
- B** Australia and New Zealand
- C** Europe (countries that approve radio equipment as per EU guidelines)
- D** Armenia
- E** Russia
- F** Vietnam
- G** Mongolia
- H** Moldova
- I** Philippines
- J** Taiwan
- K** Belarus
- L** Ukraine

Rights arising from defective performance, ŠKODA warranties

Rights arising from defective performance

Your ŠKODA Partner, as a seller, is liable to you for material defects in your new ŠKODA vehicle, ŠKODA Genuine Parts and ŠKODA Genuine Accessories, in accordance with the legal requirements and the purchase contract.

The buyer is entitled to assert the rights arising from defective performance with the responsible ŠKODA partner from the time of vehicle handover. The date of the vehicle handover and the vehicle identification number (VIN) are properly documented in the "Vehicle delivery documentation" chapter in this Owner's Manual.

ŠKODA warranty for new cars

As well as the legal rights arising from defective performance, ŠKODA AUTO grants you the ŠKODA warranty for new cars (hereinafter referred to as the "ŠKODA Warranty"), according to the conditions described below.

Under the ŠKODA Warranty, the company ŠKODA AUTO shall provide the following services¹⁾:

- ▶ Free repair of damage due to a defect that occurs in your vehicle within two years of the start of the ŠKODA Warranty.
- ▶ Free repair of damage due to paintwork flaws that occur on your vehicle within three years of the start of the ŠKODA Warranty.
- ▶ Free repair of rust corrosion on the body, which occurs on your vehicle within twelve years of the start of the warranty. In terms of rust corrosion on the body, the ŠKODA Warranty shall cover only rust corrosion through body panels from the inside to the outside.

The start of the ŠKODA Warranty is the day on which the new car is handed over for use by a ŠKODA partner to the first buyer who is not a ŠKODA Partner²⁾.

The ŠKODA Partner enters this date into the corresponding systems of the manufacturer. Any one ŠKODA Partner Partner can notify you of this date on request.

Fault rectification under the ŠKODA Warranty can be carried out by means of a replacement or repair of the defective parts. The ŠKODA Service Partner decides about the type of vehicle repair. The fault rectification takes place in accordance with the availability of the ŠKODA Service Partners and within a reasonable period of time. Replaced parts become the property of the ŠKODA Service Partner.

There shall be no further claims arising from the ŠKODA Warranty. In particular, no claim for replacement, no right of withdrawal, no claim to purchase price reduction, or provision of a replacement car for the duration of repair and compensation.

¹⁾ Based on the requirements of generally binding legal regulations or country-specific market requirements, the ŠKODA partner or importer can provide a warranty beyond the scope of the stated ŠKODA Warranty. This local warranty extends the scope of performance in accordance with the specific warranty conditions of ŠKODA partners or importers.

²⁾ Due to the requirements of the generally binding country-specific regulations, the date of first registration can be given instead of the date of the vehicle handover.

The ŠKODA Warranty can be claimed at any ŠKODA Service Partner.

There are no claims under the ŠKODA Warranty if vehicle damage has occurred in causal connection with one of the following circumstances:

- ▶ The service work was not carried out on time and professionally according to the provisions of ŠKODA AUTO, or its execution was not proven by the customer when asserting claims under the ŠKODA Warranty.
- ▶ Damage has not been reported immediately to a specialist company or has not been properly remedied.
- ▶ Damage refers to parts that are subject to natural wear, such as tyres, spark plugs, wiper blades, brake pads and brake discs, clutch, bulbs, synchronizer rings, batteries, etc.
- ▶ External impact or influences (e.g. accident, hail, flood, fire etc.).
- ▶ Installation, connection of parts or accessories, other adaptation or technical modification of the vehicle not approved by ŠKODA AUTO (e.g. Tuning).
- ▶ Unauthorized use, improper handling (e.g. use in motor sport competitions or overloading), improper care or unauthorized maintenance.
- ▶ Non-compliance with provisions in the Owner's Manual or other factory-supplied instructions.

The customer shall prove the lack of causation.

The present ŠKODA Warranty shall not affect the purchaser's statutory rights arising from unsatisfactory performance in respect of the seller of the vehicle and possible claims arising from product liability laws.

ŠKODA Mobility warranty

The Mobility Warranty provides you with a sense of certainty for journeys in your vehicle.

If your vehicle is left on the road due to an unexpected fault, we can provide services to keep you moving as part of the mobility guarantee, including the following: technical assistance on the phone, breakdown assistance at the breakdown location, start-up on site, and towing to the ŠKODA service partner, if necessary.

If your vehicle is not repaired on the same day, then the ŠKODA Service Partner may, if necessary, arrange additional subsequent services, such as replacement transport (bus, train, etc.), the provision of a replacement vehicle, and the like.

Specific claims for free provision of services under the ŠKODA Mobility Warranty only exist if your vehicle has remained in a causal connection with a defect which is to be remedied on the basis of fulfilment under the ŠKODA Warranty.

Check the conditions for provision of the Mobility Warranty for your vehicle with your ŠKODA Partner. They will also inform you of the detailed terms and conditions of the Mobility Warranty in relation to your vehicle. In the event that your vehicle is not covered by a mobility warranty, he will inform you of the possibilities for subsequent conclusion.

Optional ŠKODA Extended Warranty

If you also purchased a ŠKODA Extended Warranty when purchasing your new car, ŠKODA AUTO will provide you with a free repair of vehicle damage caused by a defect in the vehicle during the warranty period.

The ŠKODA Extended Warranty for your vehicle is valid for the agreed period or until the agreed mileage limit is reached, whichever comes first.

For the assessment of claims from the ŠKODA Extended Warranty, the conditions of the ŠKODA warranty described above apply to the appropriate extent.

The fault rectification under the ŠKODA Extended Warranty can only be carried out by replacement or repair of the defective parts, whereby the ŠKODA service partner decides on the type of vehicle repair. The fault rectification takes place in accordance with the availability of the ŠKODA Service Partners and within a reasonable period of time.

There shall in any case be no entitlement to further claims from the ŠKODA Extended Warranty. In particular, no claim for replacement, no right of withdrawal, no claim to purchase price reduction, or provision of a replacement car for the duration of repair and compensation.

The previously mentioned paint warranty and the warranty against rust perforation are unaffected by the ŠKODA extended warranty.

The ŠKODA Extended Warranty does not apply to exterior and interior foils.

Your ŠKODA partner will provide you with information about the detailed conditions of the ŠKODA Extended Warranty.

i The ŠKODA Mobility Warranty and the ŠKODA Extended Warranty are only available in some countries.

Index

Numbers and symbols

12 volt vehicle battery	205
Charge.....	205
Checking the condition.....	205
Discharge protection.....	205
Disconnecting and connecting.....	206
Fault.....	206
Safety.....	17
see 12 volt vehicle battery.....	205
12-Volt-vehicle battery	205

A

ABS	179
ACC	183
Automatic stop and start.....	183
Distance adjustment.....	184
Interruption of cruise control.....	184
Accident data recorder	240
Activation of online services	159
Adaptive Cruise Control	183
Adaptive suspension	173
AdBlue	
Checking.....	202
functionality.....	202
Indicator light.....	202
Refilling.....	202
Safety.....	17
standard.....	202
tank capacity.....	202
Air conditioning	
see Climatronic.....	59
see Manual air conditioning.....	58
Airbag	47
Deactivating the airbags.....	48
Deactivating the front passenger airbag.....	48
Fault.....	48
Installation locations.....	47
Release.....	47
Safety.....	47
Alarm system	27
Trailer.....	27
All-season tyres	211
Ambient lighting	56
Analogue instrument cluster	64
Android Auto	
Infotainment Amundsen.....	125
Infotainment Bolero.....	103
Infotainment Columbus.....	151
Infotainment Swing.....	81
see digital version of the manual.....	5
Anonymous vehicle data	159
Apple CarPlay	
Infotainment Amundsen.....	125
Infotainment Bolero.....	103
Infotainment Columbus.....	151
Infotainment Swing.....	81

see digital version of the manual.....	5
Area View	192, 194
see Area View.....	192
Armrest	
Front.....	39
rear.....	39
Ashtray	227
ASR	179
Assist systems	
Driver assist.....	179
Park Assist.....	191
Safety.....	19
Assist systems for emergency situations	189
Auto Hold	178
Automatic braking	
see Front Assist.....	180
Automatic gearbox	171
Manually changing gear with the shift paddles on the steering wheel.....	172
Manually switching gear with the selector lever.....	171
Automatic gearbox modes	171
Auxiliary heating and ventilation	61
Change the battery in the remote control.....	62
Troubleshooting.....	62
Availability of the ŠKODA Connect services	158

B

Background lighting	56
Backrest	
Load-through device.....	39
Battery acid	205
Bonnet	198
Boot	217
12 volt socket.....	217
Double-sided floor covering.....	220
Fasteners.....	218
Fastening nets.....	219
Lever for folding forward the rear seat backrests.....	217
Net partition.....	220
Rigid cover.....	220
roll-up cover.....	220
Storage compartments.....	217
Trailer hitch switch.....	217
Transporting objects safely.....	19
Variable loading floor.....	221
Boot cover	220
Boot lid	31
Automatic locking.....	31
Contactless operation.....	32
manual operation.....	31
Manually unlock.....	33
to be set to the highest position.....	32
Troubleshooting.....	32
Boot storage	
see boot lid.....	31
Brake fluid	176

- Safety..... 17
- Brake pads**..... 177
- Brakes**..... 176
- Breakdown call**..... 167
- Bulbs**..... 52
 - Front fog lights - Replacing..... 54
 - Front turn signal - Replacing..... 53
 - Rear turn signal - Replacing..... 54
- C**
- Car adaptations**
 - Recommendations..... 233
 - Safety..... 16
- Cargo elements**..... 218
- Central locking**..... 24
 - SAFE function..... 24
- Central locking button**..... 25
- Centre console**..... 11
- Charging your phone wirelessly**..... 226
- Check the vehicle before your journey**..... 17
- Child lock**..... 28
- Child seat**..... 44
 - Fastening using a belt..... 46
 - Grouping..... 44
 - i-Size..... 46
 - ISOFIX..... 45
 - Keyword child seat..... 44
 - on the passenger seat..... 44
 - Recommended child seats..... 45
 - Securing children properly..... 18
 - TOP TETHER..... 47
 - Types of mounting..... 46
- Cigarette lighter**..... 227
- Climatronic**..... 59
 - Display in the centre console at the rear..... 59
- Comfort flasher**..... 50, 51
- COMING HOME**..... 52
- Compartments**..... 222, 223
- Control Centre**
 - Infotainment Amundsen..... 110
 - Infotainment Bolero..... 88
 - Infotainment Columbus..... 136
 - Infotainment Swing..... 73
- Coolant**..... 199
 - Checking..... 199
 - Refilling..... 200
 - Safety..... 17
 - Specification..... 200
 - Temperature display..... 199
 - Troubleshooting..... 200
 - Warning lights..... 200
- Cooling system**..... 58, 59
- Crew Protect Assist**
 - see Proactive occupant protection..... 189
- Cruise control system**..... 182
- Cup holder**..... 227
- Cybernetic security**
 - Infotainment Amundsen..... 119
- Infotainment Bolero..... 97
- Infotainment Columbus..... 145
- D**
- Data connection**..... 164
- Daylight running lights**..... 49
- DCC**..... 173
- Deactivating the front passenger airbag**..... 48
- Diesel**..... 204
 - Misfuelling protection..... 204
 - Prescribed fuel..... 205
 - Refilling..... 204
 - Requirements for refuelling..... 204
 - Standards..... 204
 - Tank capacity..... 205
 - troubleshooting..... 205
- Digital Assistant Laura**
 - Columbus Infotainment..... 135
 - Infotainment Amundsen..... 109
- Digital instrument cluster**..... 65, 66
- Distribution of the cargo**..... 174
- Door**
 - Opening/closing..... 28
- Drive assistant**
 - see Travel Assist..... 186
- DriveGreen**..... 174
- Driver Alert**..... 189
 - see fatigue detection assistant..... 189
- Driver's seat**..... 11
- Driving data**..... 67
 - Reset to default..... 67
- Driving in neutral**..... 171
- DSR**..... 179
- Dynamic cornering lights**..... 49
- E**
- Earth point**..... 207
- Economical driving**..... 173, 174
- EDL**..... 179
- Electric parking brake**..... 177
- Electric windows**..... 29
 - Activation..... 29
 - Force limiter..... 28
 - Operation..... 29
 - Troubleshooting..... 29
- Emergency**
 - Emergency call..... 20
 - Using jump start cables..... 206
 - What to do after an accident..... 21
 - What to do in the event of a fire..... 21
- Emergency Assist**
 - see assist systems for emergency situations..... 189
- Emergency call**..... 20
- Emergency equipment**..... 217
 - Car jack..... 218
 - Tool kit..... 218
- Emergency wheel**..... 212
 - safe driving..... 19

- End of protection of personal data 159
 - Engine compartment 12
 - Coolant 199
 - Engine oil 198
 - Flap 198
 - Safety 17
 - Engine number 237
 - Engine oil 198
 - Changing 199
 - Checking 198
 - Indicator light 199
 - Refilling 198
 - Safety 17
 - Specification 198
 - EPC 200
 - Equipment in the boot 217
 - ESC 179
 - ESC Sport 179
 - Exhaust gas control system 201
 - Explanations 7
 - Exterior
 - lighting 49
 - Exterior mirrors 41
 - Extinguisher 218
- F**
- Fasteners in the boot 218
 - First aid kit 217
 - Flooring in the boot 220
 - Fog light 50
 - Fog lights 50
 - Fogged windows 59, 61
 - Folding table 228
 - Force limiter 30
 - Freewheel
 - Free-wheelingSee Driving in neutral 171
 - Front Assist 180
 - Front seat
 - Electrically operated 34
 - Manually operated 34
 - Front vehicle area 8
 - Fuel
 - Diesel 204
 - Petrol 202
 - Fuel filler flap 201
 - Fuel filter 201
 - Fuel tank
 - Opening the flap 201
 - Full LED headlights 49
 - Fuses 208
 - In the dash panel 208
 - Replacing 208
- H**
- Hazard warning light system 50
 - Headlights 51
 - Full LED 49
 - Headlight range control 51
 - Headrests 39
 - Heated steering wheel 64
 - Heated windscreen 63
 - HHC
 - see Hill Hold Control 179
 - High-beam
 - High-beam assist system 52
 - High-beam assist system 52
 - Hill Descent Assist System
 - Activation/deactivation 190
 - Hill Hold Control 179, 190
 - functionality 190
 - working conditions 190
 - Hook
 - in interior 223
 - in the luggage compartment 218
- I**
- i-Size 46
 - Ice scraper 10
 - Ignition lock 168
 - Images
 - Infotainment Amundsen 118
 - Infotainment Bolero 96
 - Infotainment Columbus 144
 - see digital version of the manual 5
 - Immobilizer 169
 - Indicator lights
 - Overview 12
 - Info call 166
 - Information Sport 69
 - Infotainment Amundsen 106
 - Infotainment Bolero 84
 - Infotainment Columbus 132
 - Infotainment keyboard
 - see digital version of the manual 5
 - Infotainment Overview
 - Infotainment Amundsen 106
 - Infotainment Bolero 84
 - Infotainment Columbus 132
 - Infotainment Swing 70
 - Infotainment screen
 - Infotainment Amundsen 107
 - Infotainment Bolero 85
 - Infotainment Columbus 133
 - Infotainment Swing 71
 - Infotainment settings
 - Infotainment Amundsen 106
 - Infotainment Bolero 84
 - Infotainment Columbus 132
 - Infotainment Swing 70
 - Infotainment Swing 70
 - Instrument cluster
 - analogue 64
 - digital 65
 - Instrument cluster display 64
 - Instrument cluster display 64
 - Interior

- lighting 55
- Interior fittings**
- 12 volt socket 217, 222, 223
 - 230 volt socket 223
 - Car park ticket holder 222
 - Coat hook 223
 - Glasses compartment 222
 - Make up mirror 222
 - Map pockets 223
 - Storage compartments 222, 223
 - Ticket holder 222
- Interior lighting** 55, 56
- Ambient lighting 56
 - Operation 55
- Interior mirror** 41
- ISOFIX** 46
- eyelets 46
 - Placement on the seat 45
- J**
- Jump start cables** 207
- K**
- Key** 23
- Memory function of the key 24
- Key switch for airbag deactivation** 48
- Key switch for the front passenger airbag**
- Key switch faulty 49
- Keyboard**
- Infotainment Amundsen 108
 - Infotainment Bolero 86
 - Infotainment Columbus 134
 - Infotainment Swing 72
- Keyless locking (KESSY)** 26
- Kick-down** 171
- L**
- Lane Assist** 185
- see Lane Assist 185
- Lane change assist system**
- siehe Side Assist 187
- Lap timer**
- Infotainment 69
 - Instrument cluster 68
- Launch control** 171
- LEAVING HOME** 52
- Lever**
- High-beam assist system 52
 - Main beam 50
 - Turn signal 50
 - Windscreen wipers and washers 56
- Liability for defects**
- see warranty 242
- Light** 49
- Automatically switch on and switch off 49, 51
 - Change bulbs 52
 - Changing bulbs 52
 - Clean headlights 56
 - CORNER function 49
 - Driving in the opposite direction of traffic 51
 - Fog light 50
 - Full LED headlights 49
 - Hazard warning light system 50
 - Headlamp flasher 50
 - Headlight range adjustment of headlights 51
 - High-beam assist system 52
 - Indicator light 51
 - Low beam 51
 - Main beam 50
 - Operation 50
 - Parking light 50
 - Side light 50
 - Troubleshooting 51
 - Turn signal 50
- Light Assist**
- see high beam assist system 52
- Light switch** 50
- Lightbulbs**
- High beam - Replacing 53
 - Low beam - Replacing 53
 - Parking light - Changing 53
- Lighting**
- Ambient lighting 56
 - interior 55
 - outer 49
- Lighting range** 51
- Limiters**
- see speed limiter 181
- Load-through bag** 221
- Load-through device** 39
- Lock** 24
- Locking elements**
- in engine compartment 209
- Low beam** 49
- M**
- Main beam** 50
- Management of online services** 163
- Manual air conditioning** 58
- Manual gearbox** 170
- MCB** 179
- Media**
- Infotainment Amundsen 114
 - Infotainment Bolero 92
 - Infotainment Columbus 140
 - Infotainment Swing 75
 - Playlist 93, 115, 141
 - see digital version of the manual 5
- Memory function of the key** 24
- Memory function of the seat** 34
- Mirror**
- see exterior mirror 41
- MirrorLink**
- Infotainment Amundsen 125
 - Infotainment Bolero 103
 - Infotainment Columbus 151

- Infotainment Swing_____81
- see digital version of the manual_____5
- Mirrors**
- see interior rear-view mirror_____41
- Mobile device management**
- Infotainment Swing_____78
- Mobile Device Management**
- Infotainment Amundsen_____119
- Infotainment Bolero_____97
- Infotainment Columbus_____145
- MSR**_____179
- Multi-collision brake**
- see MCB_____179
- Multifunctional holder**_____228
- N**
- Navigation**
- Infotainment Amundsen_____127
- Infotainment Bolero_____85
- Infotainment Columbus_____153
- Net partition**_____220
- Nets**_____219
- Notes on starting**_____169
- O**
- Offroad**_____173
- Offroad information_____173
- Power on / off_____173
- Oil**
- see engine oil_____198
- Online services**
- Breakdown call_____167
- Info call_____166
- Online Services**
- Availability_____158
- Data connection_____164
- Management of online services_____163
- Personalisation_____163
- Remote access to the vehicle_____168
- Service Scheduling_____167
- Shop_____166
- ŠKODA Connect_____157
- ŠKODA Connect application_____158
- System update_____165
- User Account_____163
- User management_____161
- User registration and activation of the ŠKODA
- Connect services_____158
- Vehicle status report_____167
- Operating the vehicle**
- Use jump start cables_____206
- P**
- Park Assist systems**_____191
- Park steering assistant**_____195
- Troubleshooting_____196
- Parking**
- Parking aid_____191
- Rear Traffic Alert_____194
- Reversing camera_____192
- Stop the vehicle safely!_____20
- Parking aid**_____191
- Parking brake**_____177
- see electric parking brake_____177
- Parking light**_____50
- ParkPilot**
- see parking aid_____191
- Passenger seat**_____11
- Pedestrian recognition**_____181
- Personal data**_____159, 241
- Personalisation**_____69, 163
- Change user account_____70
- Key assignment_____70
- Setting_____70
- Petrol**_____202
- prescribed fuel_____204
- prescribed petrol_____203
- Refilling_____203
- Requirements for refuelling_____203
- Standards_____203
- Tank capacity_____204
- Troubleshooting_____204
- Phonebox**_____226
- Power steering**_____40
- Practical equipment**
- 12 volt socket_____229
- 230 volt socket_____229
- Ashtray_____227
- Cigarette lighter_____227
- Cup holder_____227
- Folding table_____228
- Load-through bag_____221
- Multifunction holder_____228
- Storage compartment for the umbrella_____226
- Tablet holder_____228
- Predictive cruise control**_____183
- R**
- Radiator blinds**_____201
- Radio**
- Infotainment Amundsen_____110
- Infotainment Bolero_____89
- Infotainment Columbus_____136
- Infotainment Swing_____73
- see digital version of the manual_____5
- Radio systems in the vehicle**_____241
- Rear fog light**_____50
- Rear seats**
- Folding down_____35
- Rear Traffic Alert**_____194
- Rear vehicle area**_____10
- Rear view camera**_____192
- Rear View Camera**
- Operation_____192
- Recirculated air mode**_____58, 59
- Refilling**

- AdBlue..... 202
 - Coolant..... 200
 - Diesel..... 204
 - Engine oil..... 198
 - Petrol..... 203
 - Reflective vest**..... 217
 - Release**..... 24
 - Remote access to the vehicle**..... 168
 - Remote control of auxiliary heating and ventilation**
 - Change the battery..... 62
 - Restarting the Infotainment system**
 - Infotainment Amundsen..... 107
 - Infotainment Bolero..... 85
 - Infotainment Columbus..... 133
 - Infotainment Swing..... 71
 - Rights arising from defective performance**
 - see warranty..... 242
 - Roll-up boot cover**..... 220
 - Roof rack**..... 230
 - Roof load..... 230
 - safe driving..... 20
- S**
- Safe driving**..... 19
 - SAFE function**..... 24
 - Safety**
 - Before your journey..... 16
 - Car adaptations..... 16
 - Child seat..... 18
 - Driving through water..... 20
 - Emergency call..... 20
 - Exiting the vehicle..... 20
 - New brake pads..... 16
 - New tyres..... 16
 - Running in the engine..... 16
 - safe driving..... 19
 - Sensors and cameras..... 16
 - sit properly..... 18
 - Transport cargo and objects..... 19
 - Transporting children..... 18
 - Warning lights..... 19
 - Weather conditions..... 20
 - Webbing route..... 18
 - What to do after an accident..... 21
 - What to do in the event of a fire..... 21
 - Seat belts**..... 42
 - Adjusting the height..... 43
 - Automatic belt retractor..... 42
 - Belt tensioners..... 42
 - Blocked strap..... 43
 - correct arrangement..... 18
 - Fastening and unfastening..... 43
 - Reversible belt tensioner..... 42
 - Status display..... 42
 - Seat heating**..... 63
 - Seats**..... 34
 - Folding down..... 35
 - Heating..... 63
 - ISOFIX..... 46
 - Memory function of the seat..... 34
 - sit safely..... 18
 - TOP TETHER..... 47
 - Selector lever**..... 171
 - Service events**..... 233
 - Interval..... 233
 - Resetting information..... 233
 - Show service appointment..... 233
 - Service position for windscreen wiper arms**..... 57
 - Service Scheduling**..... 167
 - Service work**..... 233
 - Set tyre pressure values**..... 216
 - Shop**..... 166
 - Side Assist**..... 187
 - Side light**
 - see Parking light..... 50
 - Skis**..... 221
 - Sliding hooks**..... 219
 - Sliding/tilting roof**..... 30
 - electric operation of the sun blinds..... 31
 - Operation..... 30
 - SmartLink**
 - Infotainment Amundsen..... 125
 - Infotainment Bolero..... 103
 - Infotainment Columbus..... 151
 - Infotainment Swing..... 81
 - see digital version of the manual..... 5
 - Snow chains**..... 212
 - Sockets**
 - 12-volt socket..... 229
 - 230-volt socket..... 229
 - safety..... 17
 - Spare wheel**..... 212
 - safe driving..... 19
 - Speed limit**..... 68
 - Resetting..... 68
 - Settings..... 68
 - Speed limit warning**..... 68
 - Setting..... 68
 - Speed limiter**..... 181
 - Indicator light..... 181
 - Start**..... 169
 - Start the engine**..... 168
 - START-STOP**..... 170
 - Starter button**..... 169
 - Steering column lock**..... 40, 41
 - Steering wheel**..... 40
 - Buttons / dial..... 66
 - Buttons/dial:..... 40
 - correct position..... 18
 - Dials/button..... 65
 - Heating..... 64
 - Manually changing gear with the shift paddles on the steering wheel..... 172
 - Stopping the engine**..... 168, 169
 - Stopwatch**
 - Infotainment..... 69
 - Instrument cluster..... 68

- Storage** 222, 223
- Sun protection** 31
- Activating sunblind operation 31
 - electric operation of the sun blinds 31
- Supported media files**
- see digital version of the manual 5
- Supported media sources**
- see digital version of the manual 5
- Switching low beam on automatically** 49
- Switching gears**
- Manual gearbox 170
- System**
- Infotainment Amundsen 106
 - Infotainment Columbus 132
 - Infotainment Swing 70
- System update** 165
- System Update**
- Infotainment Bolero 84
- T**
- Tablet holder** 228
- Tank capacity**
- Diesel 205
 - Petrol 204
- Technical data** 237
- Dimensions 238
- Telephone**
- Infotainment Amundsen 120
 - Infotainment Bolero 98
 - Infotainment Columbus 146
 - Infotainment Swing 80
- Tilting/sliding sunroof**
- activation after disconnecting the 12-volt vehicle battery 30
 - Troubleshooting 30
- Tips for economical driving** 173
- Tiptronic** 171, 172
- Tool** 218
- TOP TETHER** 47
- eyelets 47
- Topping up**
- Windscreen washer fluid 57
- Touch operation**
- Infotainment Amundsen 107
 - Infotainment Bolero 85
 - Infotainment Columbus 133
 - Infotainment swing 71
- Tow hitch** 230
- Troubleshooting 231
 - Vertical load 232
- Tow rope** 176
- Towing a trailer** 174
- Safety 20
 - Trailer Stability Assist 179
- Towing lug** 175
- Towing the vehicle** 175
- Traffic accident**
- Data recorder 240
 - Emergency call 20
 - What to do after an accident 21
- Traffic Sign Recognition** 188
- Trailer** 174
- Alarm system 27
 - Coupling and uncoupling 231
 - Permissible load 175
 - safe driving 20
 - Swing out the tow bar and back in 230
- Trailer Assist** 196, 197
- see Trailer Assist 196
- Trailer Stability Assist** 179
- Transport**
- Roof rack 230
 - Tow hitch 230
 - Transporting objects safely 19
- Travel Assist** 186
- TSA**
- see Trailer Stability Assist 179
- Turn signal** 50
- Type plate** 237
- Tyre pressure monitor** 216
- Tyres** 210, 211
- Breakdown set 214
 - Labelling overview 211
 - Pressure 215
 - Snow chains 212
 - Tyre pressure monitor 216
 - Wear indicator 211
- U**
- Umbrella** 226
- Unlock** 26
- Update Infotainment**
- Infotainment Amundsen 107
 - Infotainment Bolero 85
 - Infotainment Columbus 133
 - Infotainment Swing 71
- Update of the system and infotainment**
- see digital version of the manual 5
- USB** 222, 223
- User Account** 163
- User management** 161
- User registration** 159
- V**
- Variable loading floor in the boot** 221
- VarioFlex** 36
- VarioFlex rear seats** 36
- VarioFlex seats**
- see VarioFlex rear seats 36
- Vehicle cleaning**
- Exterior 235
 - Instructions for cleaning the interior 234
 - Instructions for cleaning the outer area 235
 - Interior 234
- Vehicle dimensions** 238
- Vehicle driving mode** 172

Eco	173	Windscreen washer system	
Individual	173	see windscreen wiper and washer	56
Normal	173	Windscreen wiper and washer	
Offroad	173	Refill windscreen washer fluid	57
Snow	173	Windscreen washer fluid level too low	57
Sport	173	Windscreen wipers and washers	56
Vehicle height	238	automatic rear window wiping	57
Vehicle Identification Number (VIN)	237	automatic wiping	57
Vehicle length	238	Replace the windscreen wiper blade	58
Vehicle status	68	Unfold the windscreen wiper arms	57
Vehicle status report	167	Winter tyres	211
Vehicle width	238		
Vest		X	
see reflective vest	217	XDL +	179
VIN			
see vehicle identification number	237		
Virtual cockpit			
see digital instrument cluster	65		
Voice control			
Infotainment Amundsen	109		
Voice Control			
Infotainment Bolero	87		
Infotainment Columbus	135		
W			
Warning lights			
Foreword	12		
Warning triangle	217		
Warranty	242		
Mobility warranty	243		
Optional Extended Warranty	243		
Rights arising from defective performance	242		
Warranty for new cars	242		
Waste container	227		
Water in the fuel filter	201		
Weight	237		
Wheels	210		
Aero full wheel covers	217		
Breakdown	211		
Change	213		
Cover caps for the screws	216		
Full wheel covers	216		
Overview of tyre labelling	211		
Pressure change	211		
Spare wheel and emergency wheel	212		
Tyre pressure	215		
Tyre pressure monitor	216		
Wear indicator	211		
Wi-Fi			
Infotainment Amundsen	123		
Infotainment Bolero	101		
Infotainment Columbus	149		
see digital version of the manual	5		
Window	29		
heating	63		
Windscreen washer fluid			
How is the washer fluid refilled?	57		
Level too low	57		