

VOLVO
S80

VOLVO
for life

WEB EDITION



Volvo Service

Certain service remedies, which affect the car's electrical system, can only be carried out using electronic equipment specially developed for the car. Always contact your Volvo workshop, before beginning or carrying out any service which affects the electrical system.

Installing accessories

The incorrect connection and installation of accessories can negatively affect the car's electrical system. Certain accessories only function when the appropriate software has been programmed into the car electrical system. Always contact your Volvo workshop, before installing accessories which are connected to or affect the electrical system.

Recording vehicle data

One or several of the computers in your Volvo are capable of recording detailed information which may include specific details - without being limited to - regarding: frequency of seat belt use by the driver and passenger, information on various vehicle system and module functions and status information regarding the engine, throttle, steering, brakes and other systems.

This information may include details regarding the manner in which the driver operates the vehicle. This type of information can include specific details - without being limited to - regarding vehicle speed, use of the brakes, accelerator pedal or steering wheel position. This information can be stored while the car is being driven, during a collision or a near-collision.

The stored information may be read and used by:

- Volvo Car Corporation
- Service and repair facilities
- Police and other authorities
- Other interested parties who are entitled - or receive your permission for - access to this information.

Contents

An alphabetical index is at the back of the book.

	Page
Safety	7
Instruments, switches, controls	25
Climate control	45
Interior	57
Locks, alarm	67
Starting, driving, gearshifting	77
Wheels and tyres	97
Fuses, bulb replacement	103
Car care and Service	115
Specifications	133
Audio	141
Telephone	159
Index	173

In addition to describing the standard equipment this manual also covers optional and extra equipment. In addition there are also equipment alternatives, manual or automatic transmission for example. In certain countries statutory requirements affect the level of equipment. This means that it is occasionally necessary to page past sections of the book which describe equipment not installed on your car.

The specifications, design features and illustrations in this Owner's Manual are not binding. We reserve the right to make modifications without prior notice.

Dashboard - left-hand drive

Temperature gauge	26	Display	30
Speedometer	26	Tachometer	26
Odometer	26	Automatic gearbox	26
Trip odometer	26	Clock	26
Warning symbols	27	Outside temperature sensor	26
		Fuel gauge	26

Hazard warning flashers....38

Radio 141

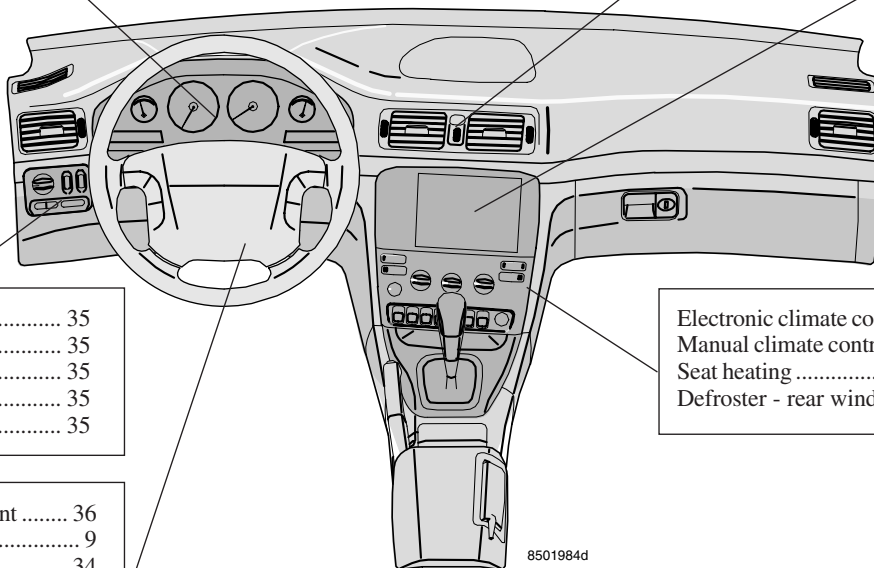

8501984d

Main/Dipped beam	35
Position/Parking lamps	35
Fog lamps	35
Instrument lighting	35
Beam length control	35

Electronic climate control ECC	48
Manual climate control A/C	52
Seat heating	38
Defroster - rear window, door mirrors	38

Steering wheel adjustment	36
Airbag	9
Cruise control	34
Radio keypad	147
Windscreen washers/wipers	37
Direction indicator lever	36
Trip computer	33

Dashboard - right-hand drive

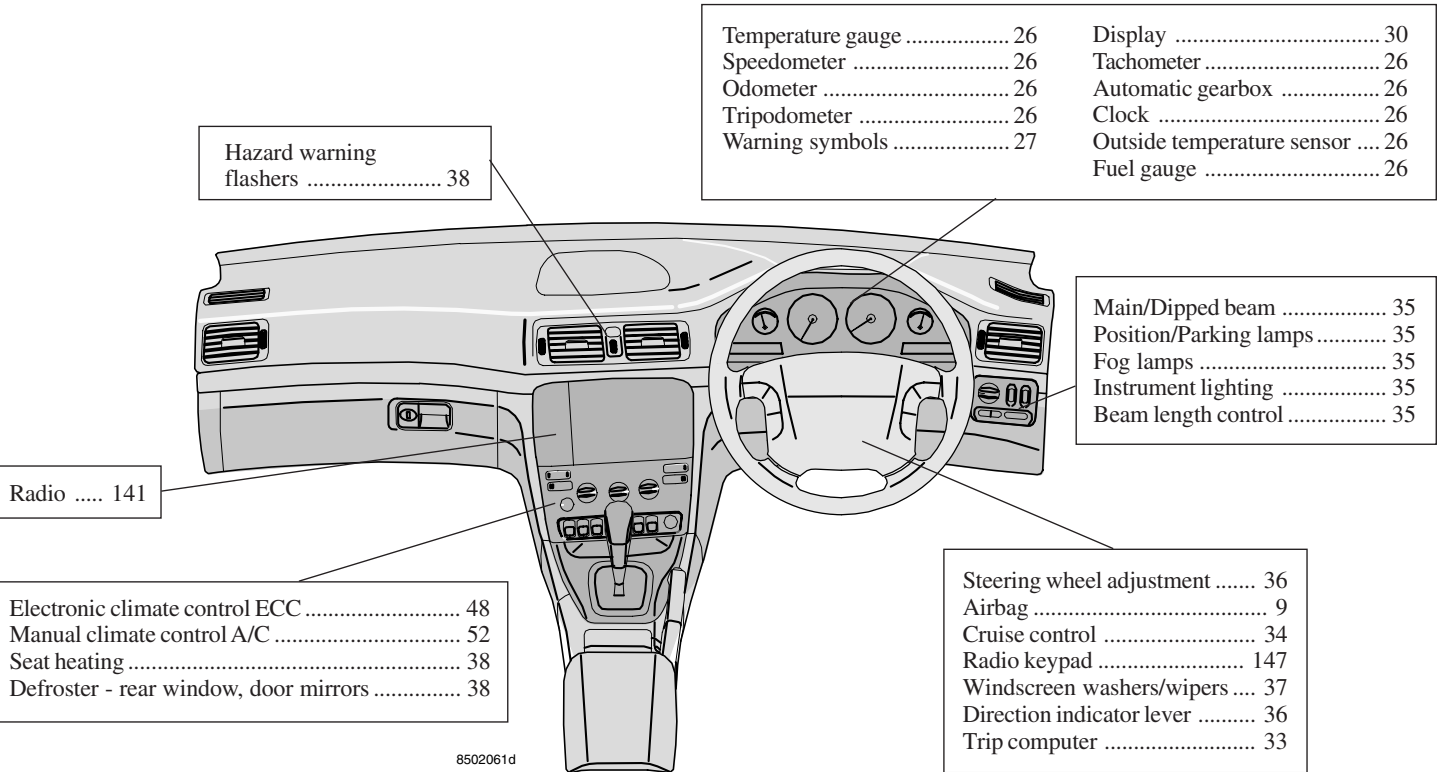

Interior - left-hand drive

Doors and Locks	68
Alarm	73
Power windows	40
Power mirror controls	41

Glovebox	62
----------------	----

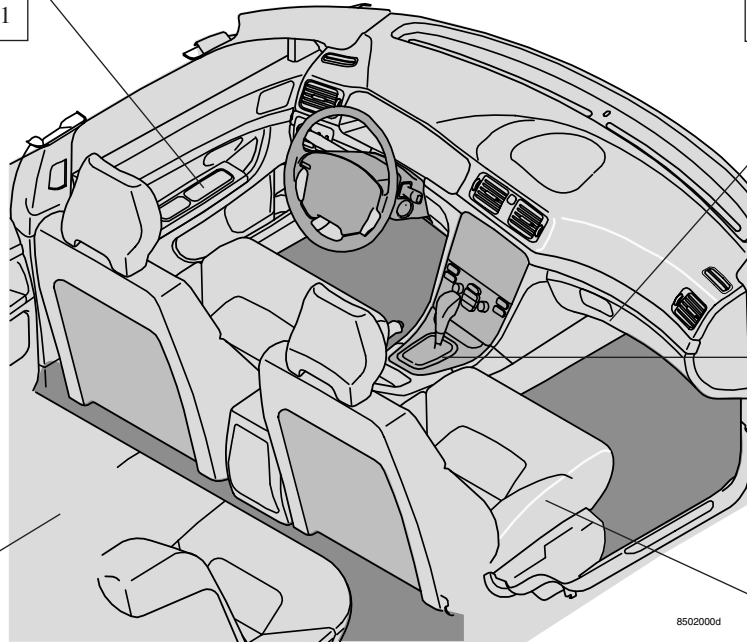

Manual gearbox	82
Automatic gearbox	83
Geartronic	85
Handbrake	39
Switch in centre console	31

Tipping backrests forward	65
Hatch for long loads	65
Tilting head restraints forward	31
Adjusting head restraints	59
Child locks	72
Integrated booster cushion for children	22

Manual adjustment of front seats	58
Electrical adjustment of front seats	60
Seat heating	38
Cleaning the upholstery	119

8502000d

Interior - right hand drive

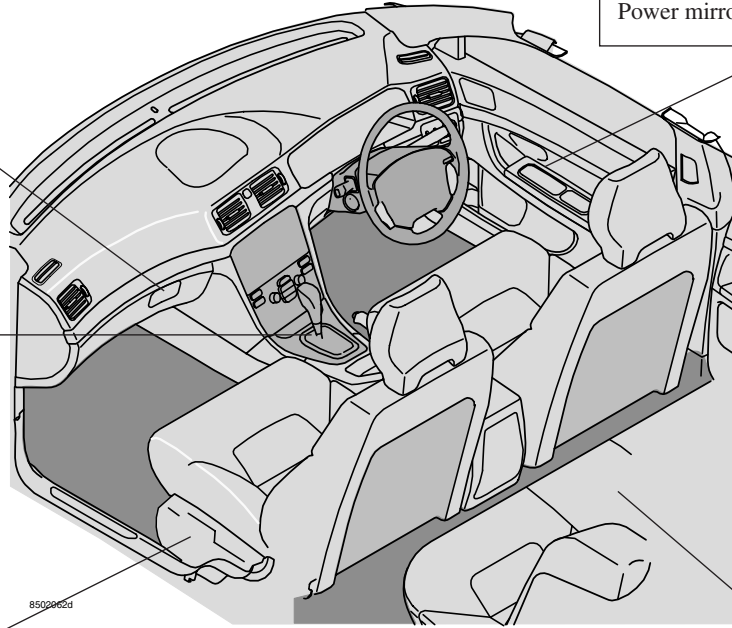

Doors and Locks	68
Alarm	73
Power windows	40
Power mirror controls	41

Glovebox	62
----------------	----

Manual gearbox	82
Automatic gearbox	83
Geartronic	85
Handbrake	39
Switch in centre console	31

Manual adjustment of front seats	58
Electrical adjustment of front seats	60
Seat heating	38
Cleaning the upholstery	119

Tipping backrests forward	65
Hatch for long loads	65
Tilting head restraints forward	31
Adjusting head restraints	59
Child locks	72
Integrated booster cushion for children	22

8502062d

Exterior

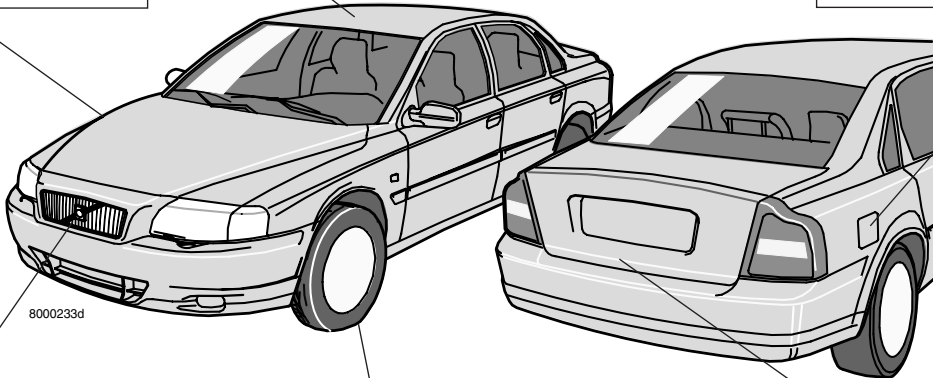

8000233d

Sunroof	42
Cleaning the car body	118
Rustproofing	116
Touching up paintwork	117
Fuel filler flap	78
Refuelling	78
Economical driving	80
Replacing main beam bulb	108
Replacing dipped beam bulb	108
Replacing position lamp bulb	109
Replacing direction indicator lamp bulb	109
Replacing fog lamp bulb	111
Replacing headlamp wiper blades	132
Tyres	97
Wheels	97
Brakes	18
Spare wheel	100
Changing wheels	102
Boot lid	70
Replacing reversing lamp bulb	110
Replacing brake lamp bulb	110
Replacing tail lamp bulb	110
Replacing direction indicator lamp bulb	110
Replacing fog lamp bulb	110
Replacing number plate lighting	112

Safety

Seat belts	8
SRS (airbag) and SIPS bag (side airbag)	9
SIPS airbag	11
IC system (Inflatable Curtain)	15
WHIPS	16
Brake system	18
Stability system	20
Children in the car	21

Seat belts

Use the seat belt for all types of driving

Even hard braking can have dangerous consequences if you are not wearing a seat belt! Therefore, always ask your passengers to use seat belts! Otherwise rear seat passengers may be thrown into the front seat backrests in a collision, injuring everyone in the car. Use the seat belt as follows: pull the belt out slowly and secure it by inserting the locking tab into the lock. A loud "click" indicates that the belt is locked. The belt is not normally restricted and you can move freely.

The belt is restricted and cannot be pulled out further:

- if it is pulled out too fast
- during braking and acceleration
- if the car leans excessively

It is important that the belt lies against the body so it can provide maximum protection. Do not lean the backrest too far back.

The seat belt is designed to protect in a normal seating position.

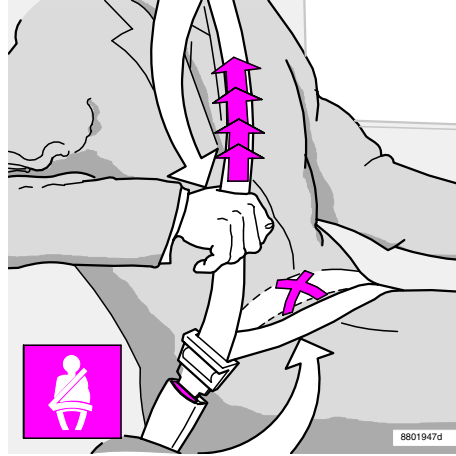

*Extending the lap belt
The lap belt should be low*

Keep in mind the following:

- do not use clips or anything else that prevents the belt from lying correctly.
- ensure the belt is not twisted or caught on anything.
- the lap belt should sit low - not over the abdomen.
- stretch the lap belt over the lap by pulling the diagonal shoulder belt as illustrated above.

Each seat belt is intended for **one** person only!

To release the seat belt: Press on the red button in the lock. Allow the reel to pull the belt in.

WARNING!



If the seat belt has been exposed to large load strain, in a collision for example, the entire seat belt assembly including reel, mountings, screws, and lock must be replaced. Even if the belt appears undamaged some of the protective properties may have been lost. Replace the seat belt if it is worn or damaged. **Never** make any modifications or repairs to the seat belt yourself; always allow a Volvo workshop to carry out the work.

SRS (airbag) and SIPS bag (side airbag)

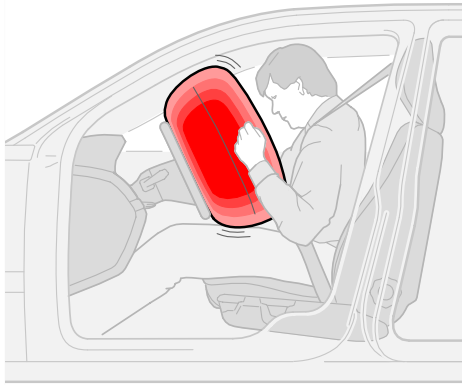

The airbag is located in the centre of the steering wheel, marked SRS

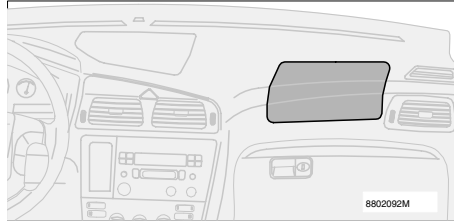
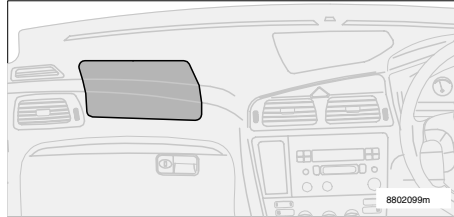

The side airbag is above the glovebox, marked SRS



The side impact airbags are installed in the front seat backrest frames

SRS (Airbag) and SIPS bag (side impact airbag)

To further increase interior safety, your car is equipped with airbags (SRS) to complement the standard three point seat belt. The car is marked SRS on the steering wheel and on the dashboard in front of the passenger, if the car has a passenger side airbag. The inflatable airbag is installed folded up in the centre of the steering wheel. On the passenger side it is folded up in a compartment above the glovebox.

SIPS (side impact airbags) further increase the interior safety of the car. The side impact airbags are installed in both front seat backrest frames.

WARNING!



Airbags (SRS) are installed as an addition to - not as a replacement for - the standard seat belts.

The side impact airbags are supplied as an addition to the existing SIPS* system. For maximum protection: **Always wear a seat belt.**

*Side Impact Protection System

SRS system (airbags in the steering wheel and dashboard)

The system consists of a gas generator (1) surrounded by the inflatable airbag (2). Upon a sufficiently violent collision, a sensor (3) reacts, activating the gas generator igniter, and the airbag inflates as it heats up. To cushion the impact, the airbag deflates when compressed. When this occurs, smoke escapes into the car. This is completely normal. The entire process, including inflation and deflation of the airbag, occurs in tenths of a second.

NOTE! The sensor (3) reacts differently depending on whether the driver's seat belt or front passenger seat belt is used or not. Crash situations can therefore occur where only one airbag is deployed.

Volvo Dual-Stage Airbag

(Dual-stage airbags)

In the event of lesser collisions, substantial enough to cause injury, the airbags inflate to slightly more than half their full capacity. In the event of collisions of greater force, the airbags inflate to their full capacity.

Seat belts and seat belt tensioners

All seat belts are equipped with a pyrotechnic seat belt tensioner (4). A small charge, integrated into the seat belt reel, ignites at the moment of impact and tensions the belt over the body so that any slack, caused by clothing etc., is minimized to restrain the occupant more rapidly. The front seat seat belt tensioners are only triggered if the seat belt is connected.

SRS system left-hand drive

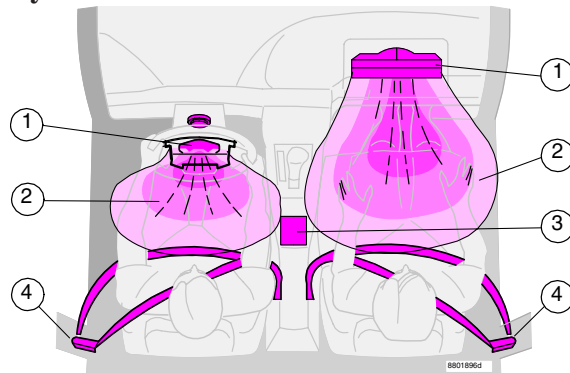

- | | |
|------------------|------------------------|
| 1. Gas generator | 3. Sensor |
| 2. Airbag | 4. Seat belt tensioner |

SRS system right-hand drive

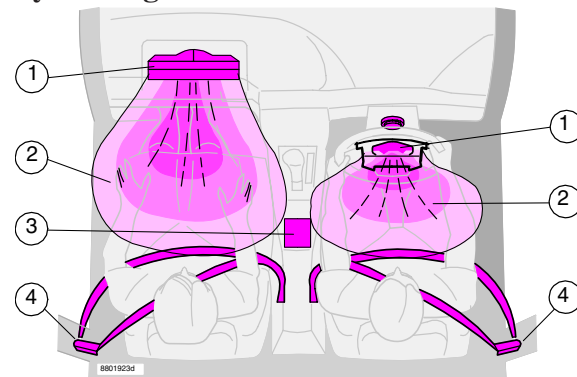

- | | |
|------------------|------------------------|
| 1. Gas generator | 3. Sensor |
| 2. Airbag | 4. Seat belt tensioner |

SIPS bag (side airbag)

SIPS bag system left-hand drive

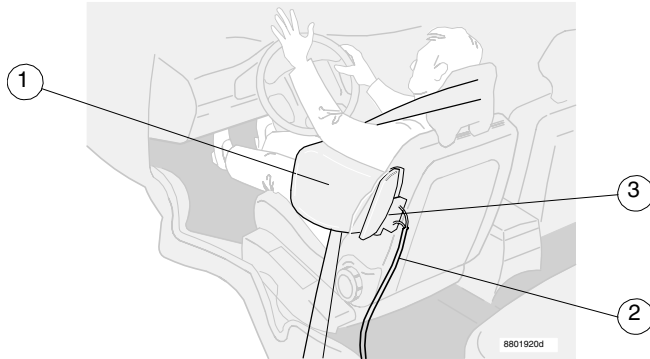

- 1. Airbag
- 2. Cable
- 3. Gas generator

SIPS bag system (side impact airbag)

This system consists of a gas generator (3), electric sensors, cables (2) and side impact airbags (1). In the event of a sufficiently violent collision the sensors react, activating the gas generator which inflates the side airbag. The airbag inflates between the occupant and the door panel, cushioning the impact at the moment of collision and then deflates. The side impact airbag only inflates on the side of the collision.

SIPS bag system right-hand drive

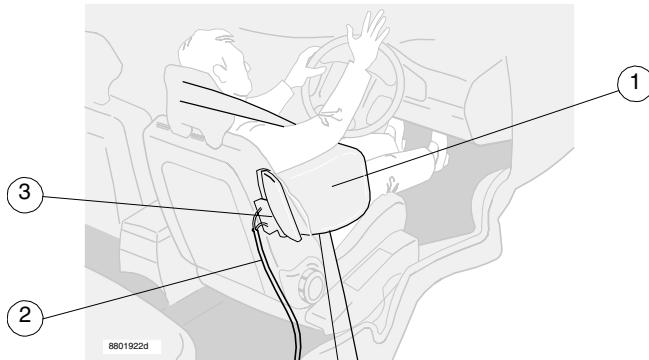

- 1. Airbag
- 2. Cable
- 3. Gas generator

SRS (airbag) and SIPS bag (side airbag)

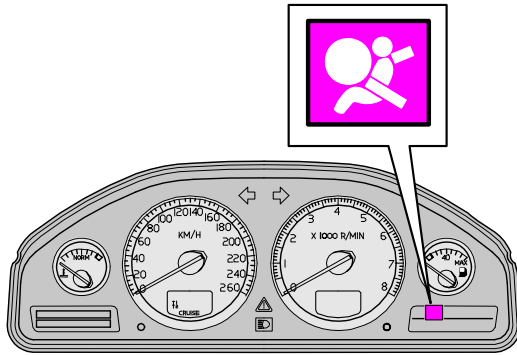

3800639d

Warning lamp in the combined instrument panel

The SRS system is continuously monitored by the sensor/control module and there is a warning lamp in the combined instrument panel. This lamp lights when the ignition key is turned to positions I, II or III. The lamp goes out when the sensor/control module has checked that the SRS system is fault-free. This normally takes approximately 7 seconds.

WARNING!



If the warning symbol (SRS) remains lit while driving it means that the SRS system is not functioning fully. Contact an authorised Volvo workshop.

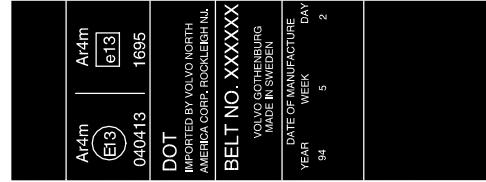

Marking on seat belts with seat belt tensioners

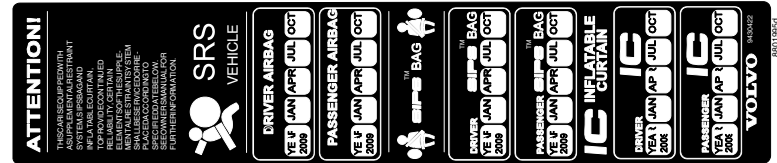

This decal is located in the rear left door opening

The year and the month given on the decal on the door pillar/s is the date when you should contact your Volvo workshop to inspect and if necessary replace the airbags and seat belt tensioners. If you have any question concerning either system, contact an authorised Volvo workshop.

WARNING!



Never try to repair any part of the SRS or SIPS bag systems yourself. Any interference can cause malfunction and serious injury and any work should be carried out by an authorised Volvo workshop.

SRS (airbag) and SIPS bag (side airbag)

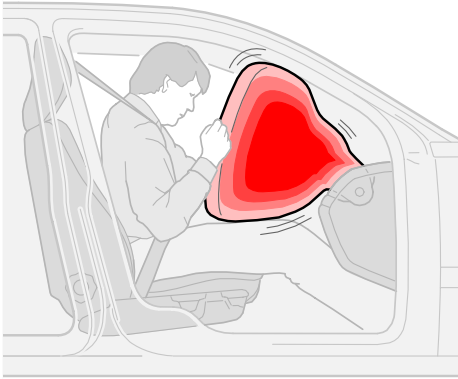

8801889a

Passenger side airbag deployment

Airbag - passenger side (option)

When the airbag is inflated the volume is approximately 150 litres on the passenger side, while the driver's side airbag, because of the location of the steering wheel, is approximately 65 litres. The crash protection is the same in both locations.

WARNING!



Airbag - passenger side

- The passenger in the front seat should never sit bent over the dashboard, at the front of the seat, or in another abnormal seating position. The passenger should sit as upright as is possible and comfortable, back against the backrest. The seat belt should be under some tension.
- Ensure that the passengers keep their feet on the floor (not on the dashboard, on the seat, in the map and newspaper compartment, or on the side window).
- Never allow children to sit or stand in front of the passenger seat.
- **Never** put a child seat or booster cushion on the front passenger seat if the car is equipped with SRS (Airbag) on the passenger side.
- **No one** shorter than 140 cm should sit in the front seat.
- No objects or accessories may be positioned or stuck on or near the SRS panel (above the glovebox) or in the area affected by the airbag.
- Do not place loose objects on the floor, seat, or on the dashboard.
- Never interfere with the SRS components in the steering wheel hub or in the panel above the glovebox.

WARNING!



Do not stick or mount your own emblems or decals on the steering wheel or dashboard!

WARNING!



SIPS airbag

- Extra seat covers must not be used on the front seats if they are not Volvo Genuine covers or Volvo approved seat covers for SIPS airbags.
- No objects or accessories may be placed between the outer side of the seat and the door panel because this area may be affected by the SIPS airbag.
- Never interfere with the SIPS airbag system.

SRS (airbag) and SIPS bag (side airbag)

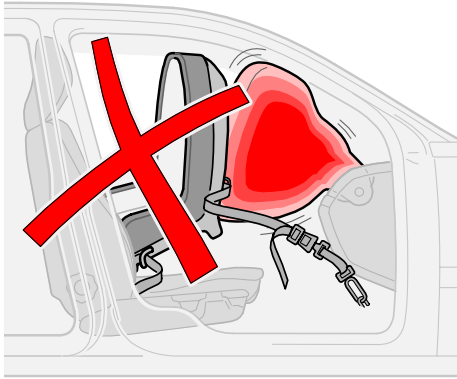

8801909e

Airbags and child seats are not compatible!

Child seat and airbag

A child can be seriously injured if a child seat or booster cushion is used in the front seat of a car equipped with a passenger side airbag.

The safest place for a child and child seat/booster cushion is the rear seat, if the car is equipped with passenger side airbag.

If the car is only equipped with SIPS airbags child seats/booster cushions can be placed in the front seat.

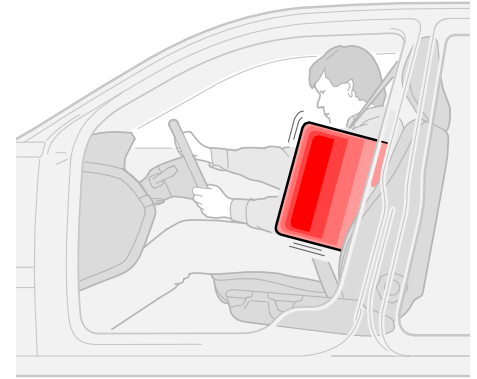

8801909e

Inflated SIPS airbag

SIPS airbag

The SIPS system is an electrical system, consisting of two main components: the side impact airbags and sensors. The side impact airbags are installed in the front seat backrest frames and the sensors are in the insides of the centre and rear pillars. The volume of the inflated side impact airbags is approximately 12 litres.

The side impact airbag normally inflates only on the side of the collision.

WARNING!



Never put a child seat or booster cushion on the front passenger seat if the car is equipped with SRS (Airbag) on the passenger side.

IC system (Inflatable Curtain)

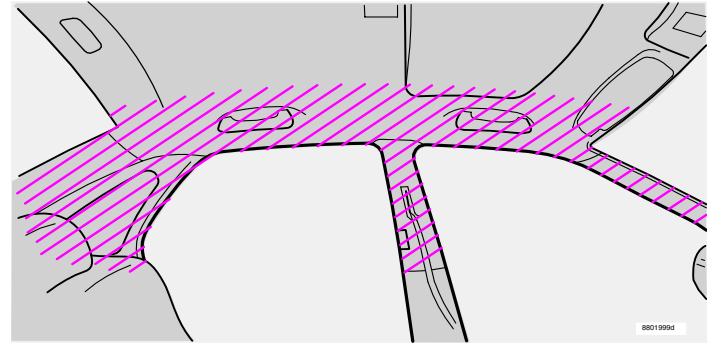
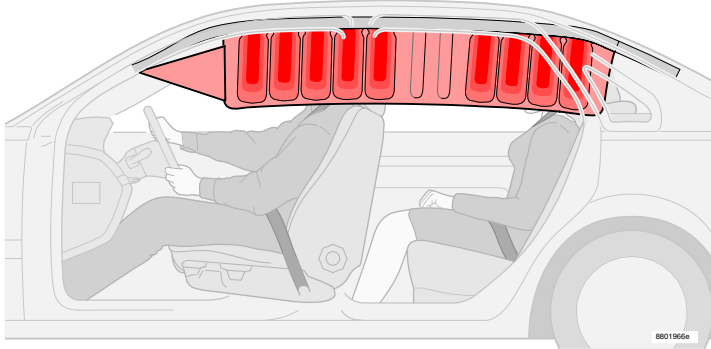

IC system (Inflatable Curtains)

The IC system protects the head from blows against the car interior. The curtain also protects against objects that the car is in collision with. The IC system protects both those travelling in the front and outer rear seats. The curtain is hidden inside the headlining. The IC system - inflatable curtains - covers the upper part of the car interior next to the front and rear seats. The IC system is activated by the SIPS system collision sensors, when the car is hit from the side. When the IC system is activated the curtain is filled with gas from the gas generator, which is located in the rear end of the curtain.

Always use the safety belts!

If you have passengers in the rear seat, ensure that the rear seat head restraints are folded up and that the centre head restraint is correctly adjusted for a passenger.

WARNING!



Do not screw or mount anything to the headlining, door pillars or side panels. The intended protection may be compromised.

WHIPS (Whiplash Protection System)

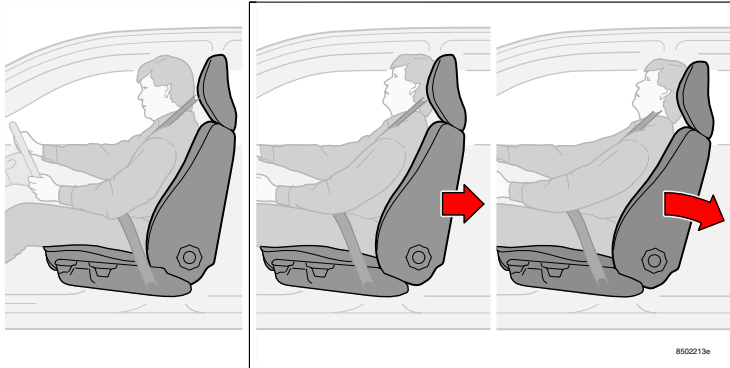

WARNING!



Never obstruct WHIPS system functions!

- If a rear backrest has been lowered, adjust the corresponding front seat in order to avoid contact with the lowered backrest.
- Avoid placing boxes or similar cargo so that they are clamped between the rear seat cushion and the front seat backrest.

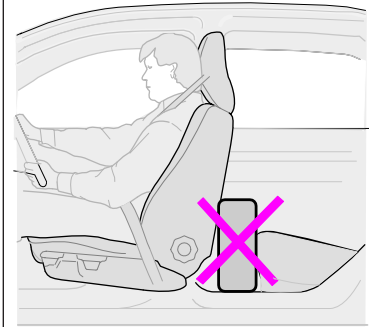

WHIPS

This system consists of energy absorbing backrests and specially developed head restraints in both front seats.

WHIPS seat

WHIPS is activated in event of a collision from behind, based on the collision angle, speed and nature of the colliding vehicle. Upon activation the backrests of the front seats, if occupied, move backwards and the seating position of the occupants in the front seats is altered. This diminishes the risk of whiplash injury.

Correct seating position

For the best possible protection, you and your front seat passenger should sit in the centre of your seats with as little distance as possible between the head restraints and your heads.

WHIPS and child seat

The WHIPS system does not negatively affect the protective properties of the car as regards Volvo child seats. As long as there is no passenger side airbag (SRS), a child seat may be placed on the front passenger seat. The WHIPS system stills functions if a rear-facing child seat is placed on the rear seat with the support against the front seat backrest.

WARNING!



If the seat has been exposed to a heavy load strain, for example a collision, the WHIPS system should be inspected at an authorised workshop. Even if the seat does not appear damaged, the WHIPS system may have deployed without causing visible damage to the seat. Parts of the WHIPS protective capacity may have been lost. Allow an authorised Volvo workshop to check the system even after minor collision from behind. Never modify or repair the seat or the WHIPS system yourself!

SRS (airbag), SIPS bag (side airbag) and Inflatable Curtain (IC)

When do the airbags and curtains inflate?

The SRS system senses the collision in the level of braking and the speed reduction caused by the collision. The sensor determines whether the collision is of the character and nature requiring the airbag deployment.

Note that it is **not only** the deformation of the bodywork which affects the car's sensors but also the speed reduction at the moment of impact. This means that the SRS sensor senses those occasions when there is a risk that occupants in the front seats may be injured by blows against the dashboard or steering wheel.

The above applies to the SIPS system (side airbags), and inflatable curtains except that side impact airbags and inflatable curtains are only deployed in **side-on collisions**, when the car is hit by an object with sufficient force.

NOTE! Deployment of the SRS, SIPS and IC systems occurs only once in a collision in the relevant direction.

If the airbags have been deployed, we recommend the following:

- Tow the car to a Volvo workshop. Do **not** drive the car with the airbags deployed even if the car can be driven after an accident.
- Let an authorised Volvo workshop replace components to the SRS, SIPS, and IC systems.

WARNING!



The SRS sensors are located in the centre console. If the passenger compartment floor has been drenched with water, remove the battery leads in the cargo compartment. Do not try to start the car; the airbags may deploy. Tow the car to an authorised Volvo workshop.

WARNING!



Never drive with deployed airbags! They can hinder the steering of your car. Other safety systems may also be damaged. Intensive exposure to the smoke and dust released when the airbags are deployed can cause eye and skin irritation. If irritated, wash with cold water and/or contact a doctor. The speed of deployment can, in conjunction with the airbag fabric, cause friction burns to the skin.



If a brake circuit fails

If a fault should occur in one of the circuits it is still possible to stop the car. Press the pedal hard once - not repeatedly. The brake pedal can be depressed further and feels a little softer than usual. It also requires more pressure on the pedal to achieve a normal braking effect.

The brake servo only works when the engine is running

If the car is rolling or being towed with the engine switched off you must apply approximately five times more pressure on the brake pedal than when the engine is running.

The brake pedal feels rigid and hard.

Moisture on the brake discs and brake lining alter braking characteristics!

The brake components become wet when the car is driven in heavy rain, through pools of water, or when the car is washed. This alters brake pad friction characteristics so that there is a delay before braking effect is noticed. Depress the brake pedal lightly from time to time when driving long distances in rain or slush or before parking the car in such conditions. The brake pads are thus able to warm up and dry out. You should also do this when driving after washing the car or when starting in very damp or cold weather conditions.

If the brakes are heavily loaded

When driving in the Alps or other roads with similar characteristics, the brakes are heavily loaded even if you are not pressing the pedal

particularly hard. Because the speed is often low the brakes are not cooled as effectively as when driving on flat roads.

So as not to overload the brakes **shift down** and use the same gear both uphill and downhill instead of using the brake (manual transmission). In this way engine braking is used more effectively and the brake is only required for short periods.

Keep in mind that the brakes are even more heavily loaded when driving with a trailer.



ABS - Anti-lock brakes

The ABS system (Anti-lock Braking System) is designed so that the wheels do not lock when braking. This retains the best possible steering response when braking. This improves your ability to swerve to avoid obstacles. The ABS system does not increase your total braking capacity. However, as the driver you have increased ability to steer and thus better control over the car, which in turn increases safety.

After the engine has started and reached a speed of about 20 km/h (12 mph), a short self-test can be both heard and felt. When the ABS system functions, you can hear and feel pulses in the brake pedal. This is completely normal.

NOTE! You must depress the brake pedal fully to take maximum advantage of the ABS system. Do not release the pedal when the ABS pulses are felt and heard. Practice braking with the ABS system in a suitable place.

The ABS symbol is lit and shines with a constant glow:



- For approximately two seconds when you start the car to test the system.
- If the ABS system has shut down due to a fault.

Electronic Brakeforce Distribution (EBD)

The EBD system (Electronic Brakeforce Distribution) is an integrated part of the ABS system. The EBD system controls the brake force to the rear wheels so that the best possible braking force is always available. Pulses in the brake pedal can be felt and heard as the system controls the brake force.

WARNING!



If both the **BRAKE**  and **ABS**  warning symbols are lit, there is a risk that the rear end will have a tendency to slide during heavy braking. If the brake fluid reservoir level is normal in these circumstances, you may, very carefully, drive the car to the nearest authorised Volvo workshop to have the brake system checked.



Stability and Traction Control STC/DSTC*

The STC system (Stability and Traction Control) contains the functions TC and SC. The DSTC system (Dynamic Stability and Traction Control) contains the functions TC, SC, AYC and EBA

Traction Control -TC

The traction control transfers the motive power from a drive wheel that spins on the road surface to the drive wheel that does not spin by braking the wheel that starts to spin. In order to increase accessibility in this situation you may need to press the accelerator harder than usual. A pulsing sound can be heard when traction control is working. This is completely normal for the system. The TC function is mostly active at low speeds. It cannot be deactivated.

Stability Control - SC

Stability Control is designed to prevent the drive wheels spinning on the road surface during acceleration, by lowering the engine torque on the drive wheels. This improves accessibility and road safety in slippery road conditions. In specific conditions, for example, driving with snow chains, in deep snow or sand, it can be beneficial to deactivate the SC function to increase traction. This is then done using the DSTC button.

Active Yaw Control - AYC

The anti-skid function performs automatic braking on one or more of the car's wheels. This stabilises the car if it starts to skid. If in this situation you attempt to apply the brakes yourself, the brake pedal will feel harder than normal and a pulsing sound will be heard. The AYC function is active the whole time and, for reasons of safety, it cannot be deactivated.

Emergency Brake Assistance (EBA)

The EBA function is an integrated part of the DSTC system. The system is designed to provide full braking force immediately when rapid braking is necessary. The system senses when you need to brake heavily by registering how quickly you press down the brake pedal.

The EBA function is active at all speeds and, for reasons of safety, cannot be deactivated.

NOTE! When the EBA function is active the brake pedal sinks at the same time as the car has maximum brake force available. Continue applying the brakes without releasing the pressure on the brake pedal. The EBA function disengages when the pressure on the brake pedal is eased.

* The STC and DSTC system is an option on some markets

STC/DSTC button

The STC/DSTC button in the centre console is used to reduce or reactivate the STC/DSTC system.

When **the LED in the button comes on** the STC/DSTC system **is activated** (if no fault arises).

When reduced the stability control (SC) is deactivated and the active yaw control (AYC) is reduced. Other functions are not affected.

NOTE! In order to reduce the effect of the STC/DSTC system for reasons of safety the button must be held in for at least a half second.

The LED in the button **goes out** and the display shows: "**STC SPIN CONTROL OFF**"/**DSTC SPIN CONTROL OFF**".

The STC/DSTC system is automatically activated each time the engine is started.

The warning symbol  flashes when...

- ...the SC function works to prevent the car's drive wheel from spinning.
- ...the TC function works to improve the car's traction.
- ...the AYC function works to prevent the car from skidding.

The warning symbol  comes on and goes off after approximately 2 seconds when ...

- ...the car starts. (The lamp comes for a system check.)

The LED in the button goes out and the text "STC SPIN CONTROL OFF/DSTC SPIN CONTROL OFF" is shown on the display when...

- ...the STC/DSTC system's SC function has been reduced using the DSTC button.

The warning symbol  lights yellow and the text "TRACTION CONTROL TEMPORARILY OFF" is shown on the display when...

- ...the brake system's TC function has been temporarily reduced due to a high brake temperature. The TC function is automatically reactivated when the brake temperature has returned to normal.

The warning symbol  lights yellow and the text "ANTI-SKID SERVICE REQUIRED" is displayed when:

- ...the DSTC system is deactivated due to a fault.

WARNING!



In normal driving conditions the STC/DSTC system improves the car's road safety, which should not be perceived as a possibility to increase speed. Always follow the usual precautions to ensure safe cornering and driving on slippery surfaces. Remember the driving characteristics of the car change if you deactivate the STC/DSTC system.

Road Friction Detection (RFD) system (option)

Road Friction Detection is an advanced system which discerns the amount of friction between the tyres and the road.

The system is designed as an early warning system which alerts the driver when road conditions are slippery.

The RFD system is active at low speed and upwards and cannot be switched off for reasons of safety.

The warning symbol  lights when:

- The RFD system detects low road surface friction.

The warning symbol  lights with a fixed, yellow glow and the additional text "RFD SERVICE REQUIRED" when:

- The RFD system has been switched off due to a fault.

Children in the car

Children should sit comfortably and safely

Remember that children, regardless of age or size, should always be securely strapped into the car. Never allow a child to sit on the knee of a passenger!

Location and equipment must be selected with regard to the weight of the child.

Volvo's own child safety equipment is designed for your car. If you select Volvo equipment, you can be sure that the mounting points and attachments are correctly positioned and sufficiently strong.

The smallest children should sit in rear-facing seats. These give children up to the age of 3 - 4 years maximum protection.

NOTE! Many countries have statutory requirements covering where the child may be located in the car. Find out what rules apply in the countries you will be visiting.

WARNING!



Never put a child seat/booster cushion in the front seat if the car is equipped with SRS (airbag) on the passenger side.

Important tips!

When using other child safety products available on the market it is important that the installation instructions are carefully read and closely followed.

These are some points that you should consider:

- The child seat should always be located according to the manufacturer's description.
- Do not attach the child seat straps to the seat springs, rails or any of the rails and struts under the seat which may have sharp edges.
- Providing that the car is not equipped with a passenger side airbag (SRS), position the child seat backrest so that it rests against the dashboard.
- Do not allow the top portion of the child seat to rest against the windscreen.

NOTE! If you have difficulties installing a child safety product contact the manufacturer for clearer installation instructions.

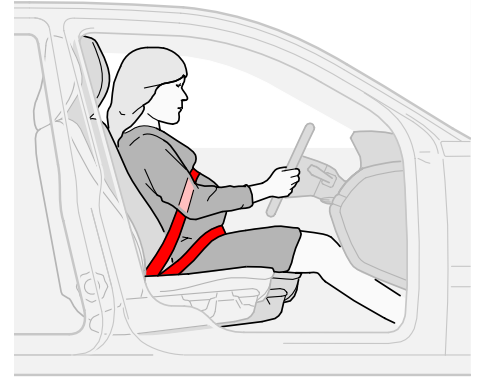

8801888e

The lap belt should be low

Pregnant women

Pregnant women should be extra careful when using seat belts! Always remember to position the seat belt so that there is no unnecessary pressure on the womb. The lap belt on the three point seat belt should be low.

Volvo's integrated booster cushion

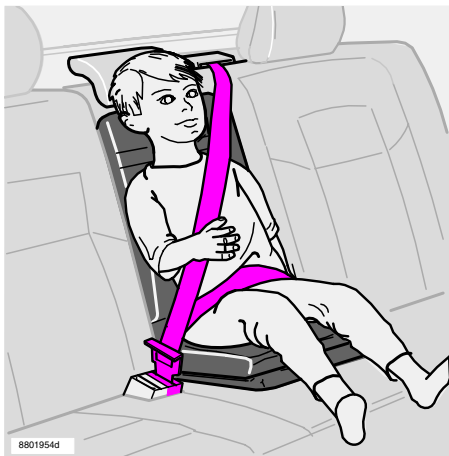

*Integrated booster cushion for children
between 15-36 kg*

Booster cushion

Volvo's integrated booster cushion for the centre rear seat is specially designed to provide optimum safety. When used with the regular three-point seat belt, the booster cushion is approved for children weighing between 15 and 36 kg.

When a child uses the booster cushion, the lap belt must be positioned low across the hips - not over the stomach.

Carefully adjust the position of the head restraint to suit the child.

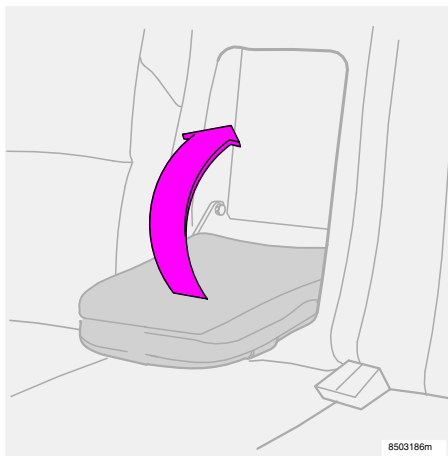

Raising the booster cushion

Raise the booster cushion. The booster cushion locks automatically in the backrest.

NOTE! See also the directions on the booster cushion.

WARNING!



If the integrated booster cushion has been exposed to heavy load, in a collision for example, the entire booster cushion, including the seat belt and screws, must be replaced. Even if the integrated booster cushion appears undamaged some of the protective properties may have been lost. The booster cushion should also be replaced if it is very worn or damaged. Note that cushion replacement must be carried out professionally, because it is important for passenger safety that the cushion is correctly installed. Therefore the replacement and any repairs should be referred to your Volvo workshop. If the cushion becomes dirty it should initially be cleaned in situ. If the cushion is so dirty that it requires separate cleaning, the above instructions for replacing and installing the cushion should be followed.

WARNING!



The regular armrest in the rear seat must not be used as a booster cushion. Only Volvo's integrated booster cushion may be used for this purpose.

Isofix bracket system for child seats (option)

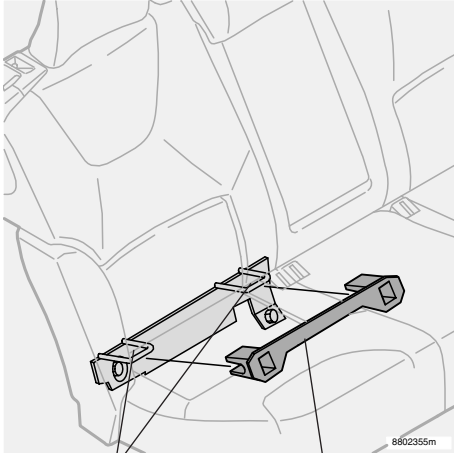

Isofix attachment points

Rail

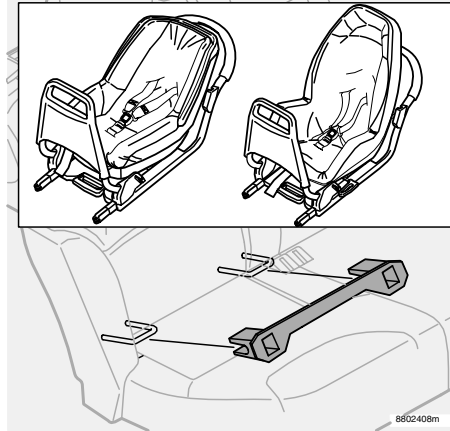

Isofix bracket system for child seats

The car can be equipped with an Isofix bracket system for child seats in the outer rear seats. Contact your Volvo dealer for further information on child safety equipment.

NOTE! Isofix attachment points are located on both outer rear seats. The rail can be moved from one side to the other as needed.

Location of the child in the car

Weight / Age	Front seat, alternatives*	Outer rear seats, alternatives	Centre rear seat, alternatives
<10 kg (0-9 months)	<ol style="list-style-type: none"> 1. Rear-facing child seat, secured with seatbelt. L: Type approval no. E5 03160 2. Rear-facing child seat, secured in ISOFIX attachment. L: Type approval no. E5 03162 3. Rear-facing child seat, secured with seatbelt and mounting strap. L: Type approval no. E5 03135 	<ol style="list-style-type: none"> 1. Rear-facing child seat, secured with seatbelt and support arm. L: Type approval no. E5 03160 2. Rear-facing child seat, secured in ISO-FIX attachment and with support arm. L: Type approval no. E5 03162 3. Rear-facing child seat, secured with seatbelt, support arm and securing strap. L: Type approval no. E5 03135 	<ol style="list-style-type: none"> 1. Rear-facing child seat, secured with seatbelt, support arm and securing strap. L: Type approval no. E5 03135
9-18 kg (9-36 months)	<ol style="list-style-type: none"> 1. Rear-facing child seat, secured with seatbelt. L: Type approval no. E5 03161 2. Rear-facing child seat, secured in ISOFIX attachment. L: Type approval no. E5 03163 3. Rear-facing child seat, secured with seatbelt and mounting strap. L: Type approval no. E5 03135 	<ol style="list-style-type: none"> 1. Rear-facing child seat, secured with seatbelt and support arm. L: Type approval no. E5 03161 2. Rear-facing child seat, secured in ISOFIX attachment and with support arm. L: Type approval no. E5 03163 3. Rear-facing child seat, secured with seatbelt, support arm and securing strap. L: Type approval no. E5 03135 	<ol style="list-style-type: none"> 1. Rear-facing child seat, secured with seatbelt, support arm and securing strap. L: Type approval no. E5 03135
15-36 kg (3-12 years)	Not a suitable placement for this age group.	<ol style="list-style-type: none"> 1. Booster cushion with or without backrest. L: Type approval no. E5 03139 	<ol style="list-style-type: none"> 1. Booster cushion with or without backrest. L: Type approval no. E5 03139 2. Integrated booster cushion. B: Type approval no. E5 03140

***) WARNING!**



NEVER place a child seat or booster cushion in the front seat if the car is equipped with a passenger side airbag.

L: Suitable for certain child seats, as listed. The child seats may be vehicle-specific, limited, half universal or universal.

B: Integrated and approved for this age group.

Instruments, switches and controls

Combined instrument panel	26
Indicator and warning symbols	27
Messages in the display	30
Switches in the centre console	31
Trip computer	33
Cruise control	34
Headlamp, Fog lamps	35
Beam length control, Instrument lighting	35
Direction indicators, Follow-me-home	
Steering wheel adjustment	36
Ignition and steering wheel lock, Windscreen washer/wipers	37
Hazard warning flashers, Rear defroster, Heated seats	38
Parking brake, Electrical socket	39
Power windows	40
Rearview mirror/door mirrors	41
Power sunroof	42
Sun blinds, Laminated side windows	43

Combined instrument panel

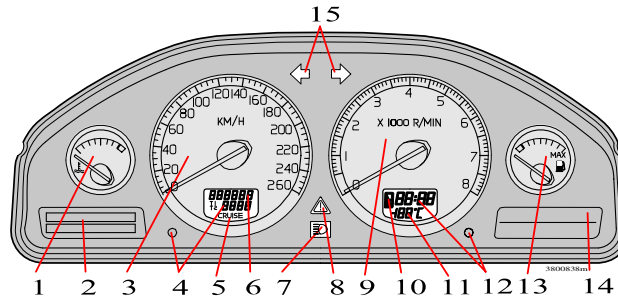

1. Temperature gauge

Displays the engine cooling system temperature. If the temperature is abnormally high and the needle enters the red field a message is shown in the display. Remember that extra lamps in front of the radiator grille reduce the cooling capacity with high outside temperatures and high engine loads.

2. Display

The display shows information and warning messages.

3. Speedometer

Shows the speed of the car.

4. Trip odometer

The trip odometer is used for measuring shorter distances. The right hand digit gives 100 meter units. Depress the button for more than 2 seconds to reset. Change between the trip odometers using one short press on the button.

5. Cruise control indicator

See page 34.

6. Odometer

The odometer indicates the total mileage of the car.

7. Main beam on/off

8. Warning symbol

If a fault should occur, the symbol lights and a message is shown in the display.

9. Tachometer

Gives engine speed in thousands of revolutions per minute (RPM). The needle on the tachometer must not enter the red field.

10. Automatic gearbox indicator

The selected gearshift programme is displayed here. If you have Geartronic automatic transmission and drive in manual mode, the current manual gear is displayed.

11. Outside temperature gauge

Displays the outside temperature. When the temperature lies between +2°C and -5°C, a snowflake symbol is shown in the display. The symbol warns of slippery road conditions. When the car is or was stationary, the outside temperature gauge may read a higher reading than is actual.

12. Clock

Turn the button to set the time.

13. Fuel gauge

The fuel tank holds 70/80 litres*. The instrument lights up when approx. 8 litres of usable fuel remain.



14. Indicator and warning symbols

15. Direction indicators - left - right

*Cars with 6-cylinder engines and all turbo models come with an 80 litre tank.

Indicator and warning symbols

The indicator and warning symbols light when the ignition key is turned to driving position (position II) before starting. This shows that the symbols are functioning. When the engine is started all the symbols go out. If the engine is not started within 5 seconds all the

symbols go out except  and . Certain symbols may not have the function indicated, depending on car equipment. The symbol for the parking brake goes out when the parking brake is released.

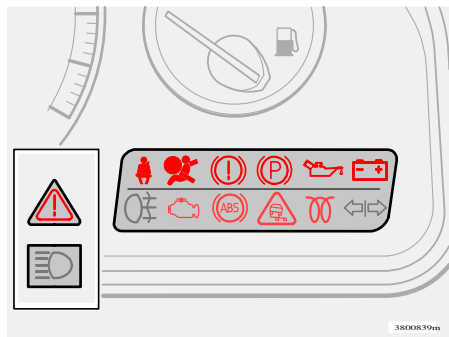

Warning symbol in centre of dashboard

This symbol shines as an **red** or **yellow** light depending on the severity of the fault discovered. See next page for more information!

WARNING!

If both the **BRAKE** and **ABS** warning symbols are lit up there is a risk that the rear end will have a tendency to slide during heavy braking.



Warning - fault in brake system

If the **BRAKE** symbol lights up the brake fluid level may be too low.

- Stop the car in a safe place and check the brake fluid reservoir level.
- If the reservoir level is below MIN the car should not be driven further. Have it towed to an authorised Volvo workshop to check the brake system.



Warning - fault in ABS system

If the **ABS** warning symbol lights up the ABS system is not functioning.

The car's normal braking system continues to function normally but without the ABS function.

- Stop the car in a safe place and switch off the engine.
- Start the engine again.
- If the warning symbol goes out, the fault was temporary and it is not necessary to visit a workshop.
- If the warning symbol remains lit, drive carefully to an authorised workshop to check the ABS system.





If **BRAKE** and **ABS** warning symbols light up at the same time, there may be a problem in the brake force distribution.

- Stop the car in a safe place and switch off the engine.
- Start the car again.
- If both warning symbols go out the fault was temporary and it is not necessary to visit a workshop.
- If the warning symbols remain lit, check the brake fluid reservoir level first.
- If the reservoir level is below MIN the car should not be driven further. Have it towed to an authorised Volvo workshop to check the brake system.
- If the brake fluid level is normal and the lamps remain lit, carefully drive the car to the nearest authorised Volvo workshop to have the brake system checked.

Indicator and warning symbols

The indicator and warning symbols light when the ignition key is turned to driving position (position II) before starting. This shows that the symbols are functioning. When the engine is started all the symbols go out. If the engine is not started within 5 seconds all the

symbols go out except  and . Certain symbols may not have the function indicated, depending on car equipment. The symbol for the parking brake goes out when the parking brake is released.



Fault in car emissions systems

Drive to a Volvo workshop to have it checked.



Rear fog lamp

The lamp lights up when the rear fog lamp is on.



Trailer indicator lamp

Flashes when the car and trailer direction indicators are in use.

If the lamp does not flash, one of the direction indicators on the trailer or car is defective.



Fault in SRS

If the symbol remains lit or lights while driving a fault has been found in the SRS system. Drive to a Volvo workshop to have it checked.



Parking brake applied

Remember that the light only indicates **that** the parking brake is applied, **not how hard**. Check by pulling the lever! **You must always pull it hard enough for the brake to fasten in a “notch”.**



Generator not charging

If the lamp lights while driving, there is probably a fault in the electrical system. Contact a Volvo workshop.



Low oil pressure

If the lamp lights while driving, engine oil pressure is too low. Stop the engine immediately and check the engine oil level.



Seat belt reminder

The lamp shines until the driver connects his/her safety belt.



Engine pre-heater (diesel)

The lamp lights to inform that the engine is pre-heating. When the lamp goes out, the car may be started. Only applies to diesel-powered cars.

Messages in the display

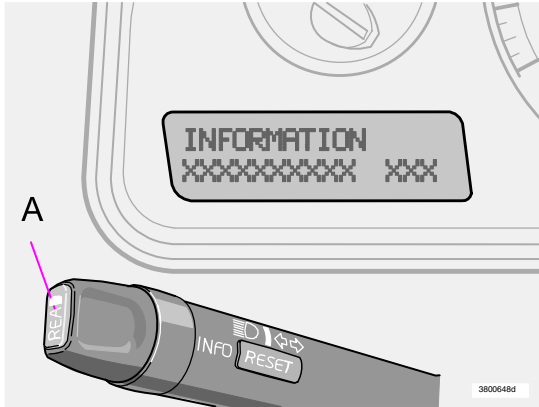

Message:

STOP SAFELY

STOP ENGINE

SERVICE URGENT

SEE MANUAL

SERVICE REQUIRED

FIX NEXT SERVICE

TIME FOR REGULAR SERVICE -

Significance/Action:

- Stop and switch off the engine. Serious risk of damage.
- Stop and switch off the engine. Serious risk of damage.
- Take your car in for service immediately.
- Consult your Owner's Manual.
- Take your car for service as soon as possible.
- Check your car at the next service interval.
- When the message is displayed, the car is due for service. The message is displayed as a function of the distance travelled, number of months since last service and engine running hours.

Messages in the display

Whenever a warning or indicator symbol lights up, a message is displayed. When you have read and understood, press the **READ** button (A). Read messages are then erased from the display and are put into the memory. The message remains in the memory until the fault is remedied.

Very serious fault messages cannot be erased from the display. They remain in the display until the fault is remedied.

NOTE! If a warning message interrupts when you, for example, are in the trip computer menu or wish to use the telephone, you must first acknowledge the message by pressing the **READ** button (A).

Messages stored in the memory can be read again. Press the **READ** button (A) if you wish to see the stored message. You can scroll through the messages in the memory by pressing the **READ** button (A). Press the **READ** button (A) to return read messages to the memory.

Switches in the centre console

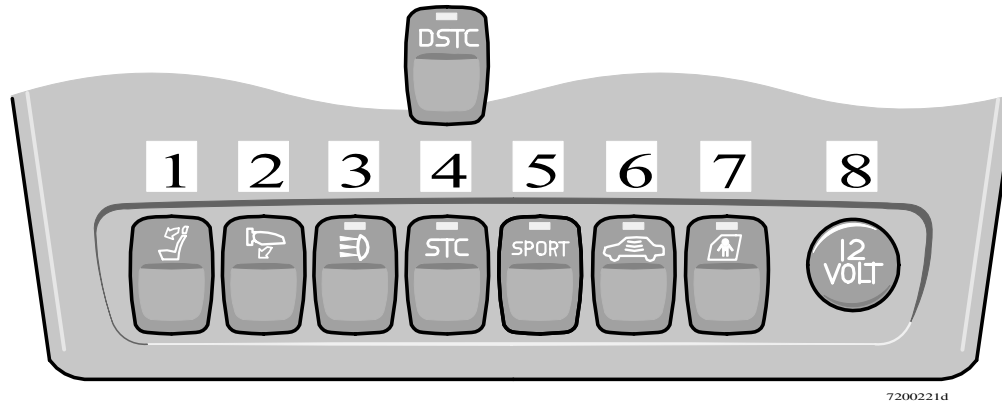

1. Tilting the outer rear seat head restraints (option)

Do not tilt the head restraints forward if there are passengers in any of the outer seats. Turn the ignition key to position I or II. Press button 1 to tilt the rear head restraints forward for a better rear view. The head restraints are tilted back manually. The head restraints must be in the upright position if you wish to fold the rear backrests down.

2. Retractable door mirrors (option)

This button is used to retract the door mirrors if they are folded out, or to fold them out if they are retracted.

Do as follows if a door mirror has been accidentally folded in or out:

- Manually fold the door mirror forward as far as possible.
- Turn the ignition key to position II.
- Fold the door mirror inward and then outward using the button. The door mirrors have now returned to their original fixed positions.

3. Auxiliary lamps (option)

Use this button to switch the auxiliary lamps on or off. The LED in the button is lit when the lamps are on.

4. The STC/DSTC system*

This button is used to reduce or reactivate the functions in the STC/DSTC system. When the LED in the button comes on, the STC/DSTC system is activated (if no fault arises).

In order to reduce the effect of the STC/DSTC system for reasons of safety the button must be held in for at least a half second.

The text "STC SPIN CONTROL OFF" / "DSTC SPIN CONTROL OFF" is shown on the display

Reduce the system if you must use a wheel of a different dimension than the other wheels.

The STC/DSTC system is reactivated when the engine is started.

WARNING!



Remember the driving characteristics of the car change if you deactivate the STC/DSTC system.

* Option on some markets

Switches in the centre console

5. Active chassis, FOUR-C (option)

FOUR-C (Continuously Controlled Chassis Concept) is an advanced, electronically-controlled active chassis system. Suspension system characteristics can be selected when driving style is changed or if the quality of the road surface changes. The button on the dashboard can be used at random in order to select from two different settings: Comfort and Sport.

Comfort

Comfort adjusts the chassis setting so that the body is insulated from uneven sections of the road surface, which allows for better glide. Shock absorption is softer and body movements are minimal. This setting is recommended for long-distance driving or driving on slippery road surfaces.

When the ignition is switched off in Comfort setting, the chassis will resume the same mode when the car is re-started.

Sport

The Sport setting provides quicker steering response than the Comfort setting. The suspension is harder and the body follows the road in order to reduce roll during rapid cornering.

When the ignition is switched off in Sport setting, the chassis will resume the same mode when the car is re-started. The LED in the button lights when Sport setting is active.

6. Deactivating the deadlock function and detectors

Use this button if you wish to shut off the deadlock function (deadlock means that the doors cannot be opened from the inside when they are locked). This button is also used to deactivate the movement and tilt detectors in the alarm system. The LED lights when these systems are deactivated.

7. Child safety locks in the rear doors (option)

Use this button when you wish to activate or deactivate the electric child safety locks in the rear doors. The ignition key must be in position I or II. When the child safety locks are activated, the LED in the button lights. A message is shown in the display when you activate or deactivate the child safety locks.

8. Electric socket/Cigarette lighter (option)

The electric socket can be used for various 12V accessories, such as mobile phones or coolers. The cigarette lighter is activated by pushing in the button. Once the lighter is heated, the button will pop out. Pull out the lighter to use it. For reasons of safety, always keep the lighter in the socket when it is not in use. The maximum current is 10A.

NOTE! The relative positions of the buttons can vary.

Trip computer (option)

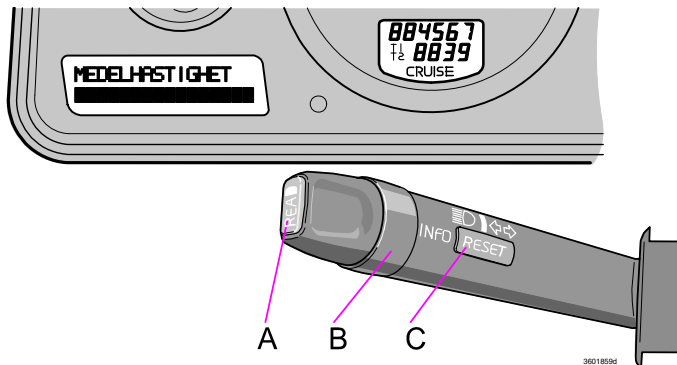

Trip computer

The trip computer receives data which is continuously evaluated by a micro-processor. The system has four menus which are shown in the display:

- **Range to empty fuel tank**
- **Average fuel consumption**
- **Current fuel consumption**
- **Average speed**

NOTE! If a warning message interrupts while you are using the trip computer menu, you must acknowledge the warning message. Then press the READ button (A) to return to the trip computer.

Controls

In order to access the trip computer information turn the ring (B) in steps, either forwards or backwards. By turning again you return to the starting point.

Average speed

The average speed since the last reset (**RESET**). When the ignition is switched off, the average speed is stored and used as the basis of the new value when you continue driving. This can be reset with the **RESET** button (C) on the lever.

Current fuel consumption

Continuous information on current fuel consumption. Fuel consumption is calculated every second. The figure in the display is updated every few seconds. When the car is stationary “----” is displayed.

NOTE: The displayed value may be slightly off if a fuel-driven heater is used.

Average fuel consumption

The average fuel consumption since the last reset (**RESET**). When the ignition is switched off, the average fuel consumption is stored and remains until reset with the **RESET** button (C) on the lever.

NOTE: The displayed value may be slightly off if a fuel-driven heater is used.

Range to empty fuel tank

Displays the range available with the remaining fuel, calculated using the average fuel consumption over the last 30 km (18 miles) and the quantity of fuel remaining. When the range to empty is less than 20 km (12 miles) “----” is displayed.

NOTE: The displayed value may be slightly off if a fuel-driven heater is used.

Cruise control (option)



Activating

The controls for cruise control are to the left in the steering wheel.

Setting desired speed:

- Press the CRUISE button. "CRUISE" is displayed in the combined instrument panel.
- The speed can be increased or decreased by pressing the + or - button.
NOTE! Cruise control cannot be engaged at speeds below 35 km/h (22 mph).
- Press + or - lightly to lock desired speed.

Temporary disengagement

Press **0** to temporarily disengage the cruise control.

The previously set speed is disengaged when the brake or clutch pedal is depressed. The previously set speed is stored in the memory.

Cruise control is also temporarily disengaged if:

- the speed goes below the engagement limit.
- the gear selector is put in position N
- wheel spin/ wheel lock occurs.

Resuming speed

Press **↻** and the car will resume the previously set speed.

Acceleration

A temporary increase in speed, when overtaking for example, does not affect the cruise control setting. The car resumes the previously set speed. When cruise control is already engaged the speed can be increased or decreased by holding the + or - button depressed. A short press corresponds to 1 km/h. The speed the car has when the button is released will be programmed instead.

Disengagement

Press CRUISE to disengage cruise control. "CRUISE" will disappear from the combined instrument panel.

Cruise control automatically disengages when ignition is switched off.

NOTE! If any cruise control buttons are held depressed for longer than a minute, the system will disengage. To reset cruise control, car ignition must be switched off.

Headlamps, Fog lamps, Beam length control, Instrument lighting

A - Headlamps and position/parking lamps

0 All lighting off.

Cars with daytime running lights:

Ignition key in position II: Dipped beam lit (and front and rear position/parking lamps, numberplate lighting and instrument lighting). **Dipped beam lights automatically when the ignition key is turned to the “driving position” and cannot be switched off.**

DE Position/Parking lamps front and rear.

D **Ignition key in position 0:** all lighting off.

Ignition key in position II: headlamps (and position/parking lamps front and rear, numberplate lighting and instrument lighting) lit.

NOTE! The light switch must be turned to position **D** for the main beam to be turned on.

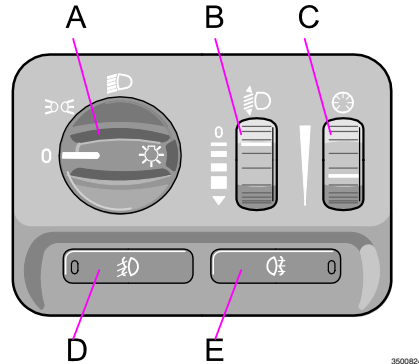

B - Beam length control

Certain models are equipped with an actuator motor at each headlamp in order to control the headlamp beam length with different loads in the car. Beam length is controlled using the beam length control in the dashboard. Cars with Bi-Xenon lighting (option) have automatic headlamp levelling.

C - Instrument lighting

Move the control upward - brighter lighting
Move the control downward - dimmer lighting

A twilight sensor (see page 48) automatically regulates all instrument lighting.

D - Front fog lamps

Ignition key in position II. Press the button. The fog lamp lights in combination with the parking lamps. The LED in the button lights when the fog lamp is lit.

NOTE! In certain countries, dipped beam may not be used in conjunction with fog lamps.

E - Rear fog lamps

Ignition key in position II. Press the button. The rear fog lamps light in combination with the main/dipped beam. The LED in the button and the symbol in the combined instrument panel light at the same time.

Please remember: Regulations for use of front and rear fog lamps vary from country to country.

Cars with daytime running lights

Before trips to certain countries, your Volvo workshop can help you deactivate the daytime running lights.

Direction indicators, Follow-me-home, Steering wheel adjustment

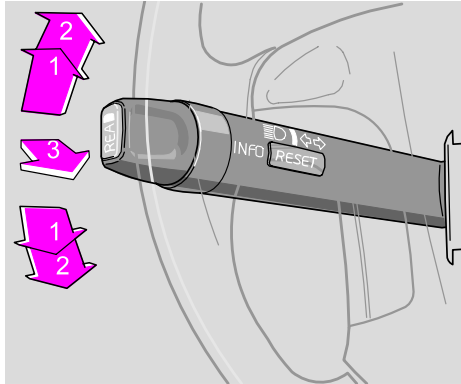

3 Main beam flash

Pull the lever lightly towards the steering wheel (until you feel a slight resistance). Main beam is lit until the lever is released.

3 Main/dipped beam switch (Switch on headlamps)

Press the lever towards the steering wheel past the “flash position” and release it again. The headlamps change between main and dipped beam.

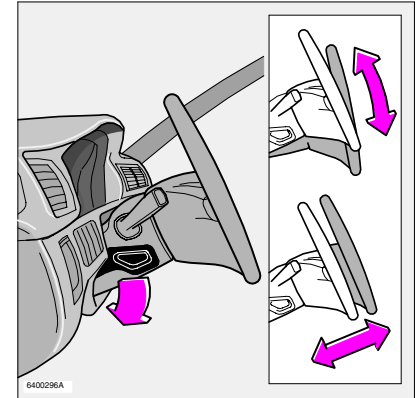

Direction indicators, main/dipped beam switch and main beam flash

1 “Resistance point position”

For turns requiring small steering adjustments (lane changing, overtaking) move the lever up or down and hold it with a finger. The lever returns immediately to the neutral position when it is released.

2 Normal turns

Follow-me-home

Do as follows when you **leave your car** when it is dark out:

- Remove the key from the ignition switch.
- Pull the left hand lever towards you (as in main beam flash)
- Lock the doors.

The dipped beam position/parking lamps, numberplate lighting, side marker lamps and lamps in the door mirrors now light. These lamps remain lit for 30, 60, or 90 seconds. The time settings for your car can be changed by an authorised Volvo workshop.

Steering wheel adjustment

The steering wheel can be adjusted both vertically and front-rear. Push down the control on the left-hand side of the steering column. Then adjust the steering wheel to the position that suits you best. Ensure that the steering wheel fastens in a determined position (notch). Press the control back into place to lock the steering wheel.

WARNING!



Adjust the steering wheel before driving, never while driving. Ensure that the steering wheel is locked.

Ignition and steering wheel lock, Windscreen wipers/washer

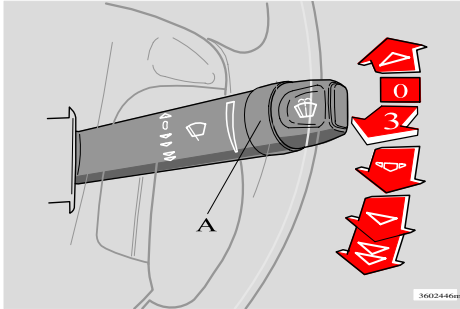

Windscreen wipers

0 - Windscreen wipers switched off. If the lever is in the **0** position and you draw it upwards, the wipers will continue one swipe at a time as long as you hold the lever up.

 - **Intermittent wiping.** The speed of the intermittent wipe can be adjusted and set. Twist the ring (see A in illustration) upwards to increase the wiper stroke frequency. Twist the ring downwards to decrease the wiper stroke frequency.

Rain sensor (option)

The rain sensor replaces the intermittent function. The windscreen wipers automatically increase or decrease speed based on how much water the sensor indicates is on the windscreen. **Sensitivity** can be adjusted using the ring (see illustration).

To activate the rain sensor function:

- Switch on the ignition.

- Move the lever from position 0 to the position for intermittent wiping.

The rain sensor is deactivated when the ignition is switched off completely.

To reactivate the rain sensor function:

- Switch on the ignition.
- Move the lever to position 0 and then to the position for intermittent wiping.

NOTE:

When using a car wash: Disengage the rain sensor (move the lever to position 0) or switch off the ignition completely. Otherwise, the windscreen wipers will begin swiping and can be damaged.

 - Wipers operate at normal speed

 - Wipers operate at high speed

3 – Windscreen/headlamp washer

The windscreen and headlamp washers are started by pulling the lever **back**.

Ignition keys and electronic immobilizer

Do not let several ignition keys, each containing a chip, dangle on the same keyring when inserting the key in the ignition switch. The immobilizer could be activated. If this happens, take away the excess keys and restart the car.



Ignition and steering wheel lock

0 Locked position

The steering wheel locks when the ignition key is removed.



I Intermediate position - “radio position”

Certain electrical components can be connected. The engine electrical system is not connected.



II Drive

The key position when driving. The car’s entire electrical system is connected. Diesel: Wait until pre-heating is finished. See page 78.



III Start position

The starter motor is connected. Release the key when the engine has started. The key springs back to the driving position automatically.

If the key is difficult to turn the front wheels are positioned so that there is tension in the steering wheel lock. Turn the steering wheel back and forth while turning the key.

Ensuring that the steering wheel is locked when you leave the car minimises the risk of theft.

WARNING!



Never switch off the ignition (key in the position 0) or pull out the ignition key while the car is moving. This can activate the steering lock, which makes the car impossible to drive.

Hazard warning flashers, Rear defroster, Heated seats

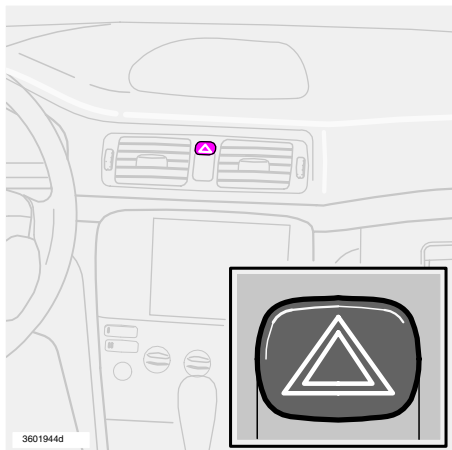

Hazard warning flashers

The hazard warning flashers (all direction indicators flash) should be used when you are forced to stop or park the car where it is a hazard or hindrance to traffic.

Please remember: Regulations for using hazard warning flashers vary from country to country.

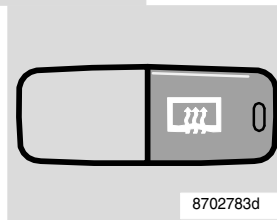
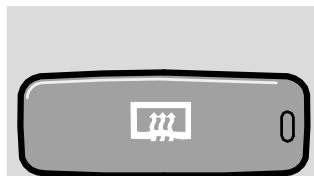

Heated door mirrors Rear defroster

Use the defroster to remove ice and misting from the rear window and door mirrors. Pressing the switch starts heating the rear window and the door mirrors at the same time. The LED in the switch lights. A built-in timer automatically disconnects the defroster from the door mirrors after approximately 6 minutes and from the rear window after approximately 12 minutes.

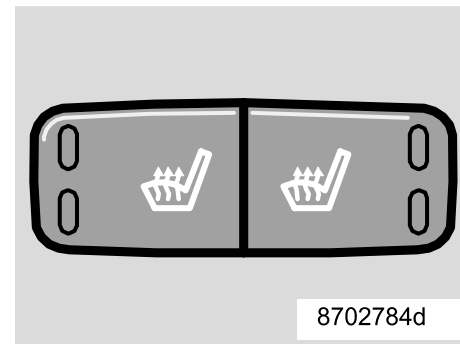

Front seat heater switch

Heated front seats

If you wish to have extra heat in the front seat(s) carry out the following:

- Press **once**: High heat - both LEDs in the switch light up.
- Press **once again**: Low heat - one LED in the switch lights.
- Press **once again**: heating switched off (no LEDs are lit).

Your Volvo workshop can adjust the temperature.

Parking brake, Electrical socket/cigarette lighter

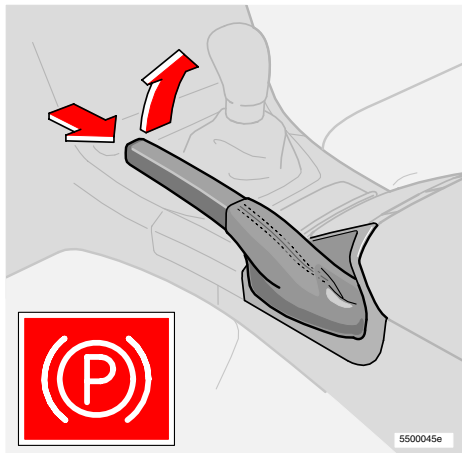

Parking brake lever

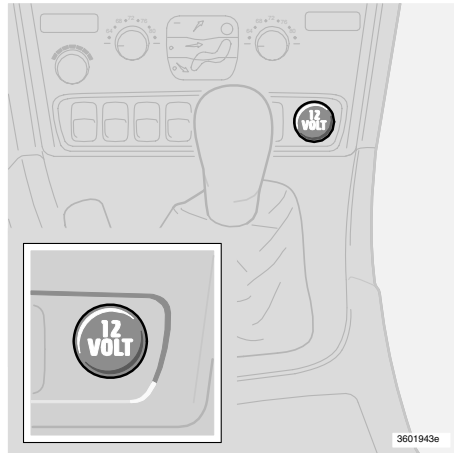

Electrical socket at the front seat

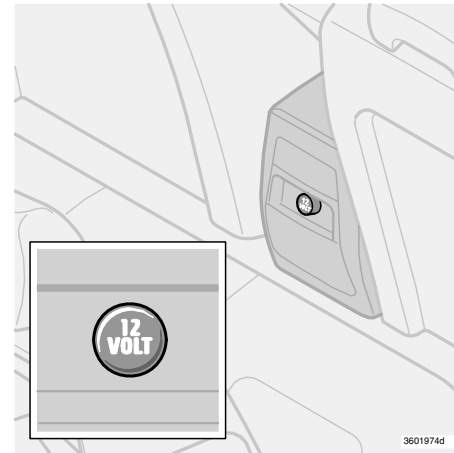

Electrical socket for the rear seat

Parking brake (handbrake)

The lever is located between the front seats. The parking brake operates on the rear wheels. The warning symbol in the combined instrument panel lights when the brake is applied. Pull up the lever slightly and press in the button to release the brake.

Remember that the warning symbol in the combined instrument panel lights even if the parking brake is only “slightly” applied. Check that the brake is applied correctly. **You must always pull the lever hard enough to fasten it in a “notch”.**

Electrical socket/cigarette lighter

The cover should always be in position if the socket is not being used as a power source or as a cigarette lighter socket. The maximum current is 10A.

Power windows

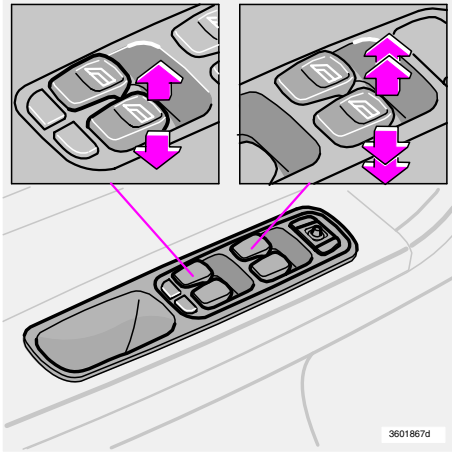

Windows can be opened or closed from the front seat two ways.

1. Press the switch **gently** downwards or pull it **gently** upwards. The power windows go up or down as long as the switch is affected.
2. Press the switch **all the way** down, or pull it **all the way** up, and **then release it**. In this position (AUTO-DOWN - AUTO-UP*), the power windows open or close automatically.

If you close the front windows using the AUTO function an integrated clamp protection is activated if the window is blocked by any object.

NOTE! The AUTO-UP function on the **passenger side** is only available on some markets.

The power windows are operated using the switches in the door armrests. The ignition key must be turned to the radio or driving position* for the power windows to function. The window opens when you **depress** the front section of the switch and closes when you **pull up** the front section of the switch.

*When you have finished your trip and removed the ignition key, you can still close or open the windows **as long as you have not opened either of the front doors**.

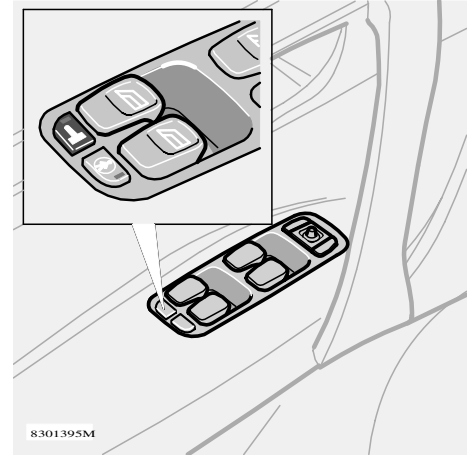

Rear power window switches

The power window switches in the rear seat can be blocked from the switch on the driver's door switch panel. Always remember to break the current to the power windows (that is to say remove the ignition key and open one of the front doors*) when you leave children in the car unattended.

LED in the switch unlit:

The rear door windows can be operated both by the switch in each door but also by the switch in the driver's door.

LED in the switch lit:

The rear windows can **only** be operated from the driver's door.

WARNING!

When children are in the car, make sure that their hands are clear when closing the rear windows.



Rearview mirror/door mirrors

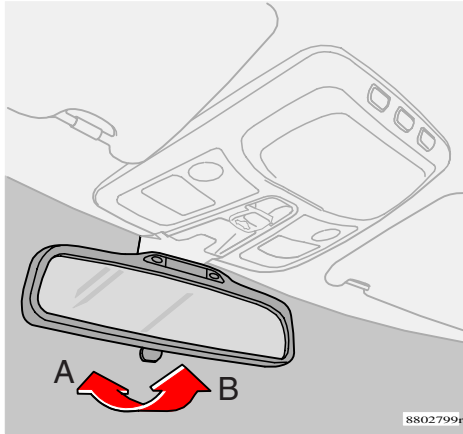

Rearview mirror

A normal position.

B dimming position. Use this if headlamps from the cars behind irritate you.

Certain models have an **autodim** function, which leads to an automatic dimming based on current light conditions.

Seat belt reminder

The seat belt warning symbol above the rearview mirror flashes as long as the **driver's** seat belt has not been connected.

In certain models, the seat belt reminder switches off after 6 seconds. If the driver has

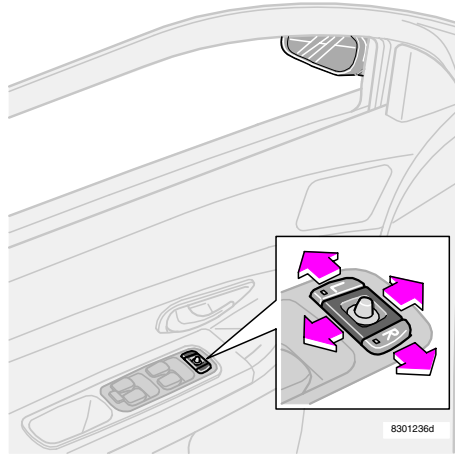

Switches, power door mirrors
not fastened his seat belt, the reminder is switched back on when speed exceeds 10 km/h (6 mph) and switches off when speed falls below 5 km/h (3 mph). If the belt is unfastened, this function is activated again when speed exceeds 10 km/h (6 mph).

Door mirrors

The switches for setting the two outer door mirrors are furthest forward on the driver's door armrest.

Press the switch. L = left door mirror.

R = right door mirror.

LED in the switch lit: Adjust the position with the adjustment control. When you have set the position press the switch once. The LED should no longer be lit.

Storing mirror settings in the remote control

Unlocking the car with one of the remote controls and changing the mirror settings will cause the new positions to be saved in the remote control. The next time the car is unlocked with the same remote control and the driver's door is opened within two minutes, the mirrors will assume the saved positions.

NOTE! The above only applies if your Volvo is equipped with a driver's power seat.

Do not use ice scrapers with steel blades to remove ice from the mirrors as the glass could be scratched!

WARNING!



Adjust the mirrors before you begin driving!

The outer half of the door mirror on the driver's side is a wide-angle mirror that eliminates the "blind spot".

Bear in mind that angles and distances in the mirror image are distorted!

Power sunroof (option)

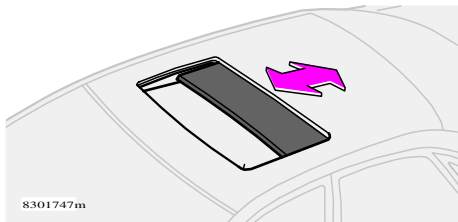
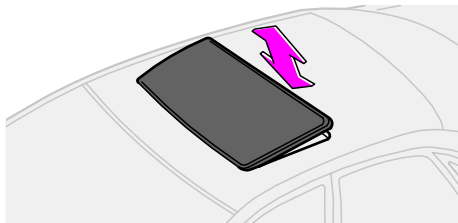

8301747m

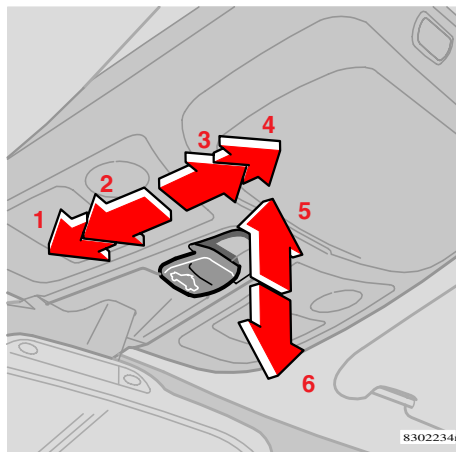

8302234e

1. Automatic closing
2. Manual closing
3. Manual opening
4. Automatic opening
5. Opening ventilation position
6. Closing ventilation position

Power sunroof (option)

Sunroof controls are located in the headlining. The sunroof can be opened in two different ways:

- Raise/lower trailing edge (ventilation position)
- Rearwards/forwards (opening position/comfort position*)

The ignition key must be in position I or II.

Ventilation position

Open: Push the trailing edge of the switch (5) upwards.

Close: Pull the trailing edge of the switch (6) downwards.

It is possible to switch directly from the **ventilation position to comfort position***: pull the control backwards to its end position (4) and release.

* In comfort position, the sunroof is not completely open in order to reduce the level wind noise.

Opening position/comfort position*

Automatic control

Move the control over the resistance point position (3) to the rearmost end position (4) or over the resistance point position (2) to the front end position (1) and release. The sunroof will open to the **comfort position*** or will close completely.

Open from **comfort position*** to max. opening: pull the control to the rear once more to the end position (4) and release.

Manual control

Open: Pull the switch rearwards to the resistance point position (3). The sunroof will move towards maximum opening position as long as the switch is held in this position.

Close: Press the switch forwards to the resistance point position (2). The sunroof will move towards its closing position as long as the switch is held in this position.

Pinch protection

NOTE! The sunroof pinch protection function is activated if the hatch is blocked by an object. If blocked, the sunroof will stop and automatically open to the previous open position. This function will be activated only when the sunroof is in the open position.

WARNING!



Pinch protection functions only in the opening position - not in ventilation position.

Make sure the sunroof is properly closed before leaving the car.

WARNING!



When closing the sunroof, make sure that no hands are in the way.

Sun blinds (option), Laminated front and rear side windows (option)

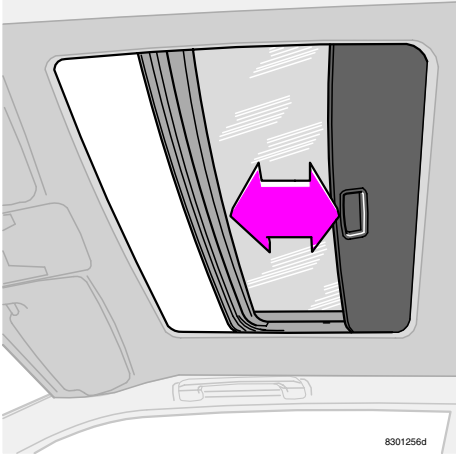

Sun screen

The sunroof also has an inner manually sliding sun screen. The sun screen slides back automatically when the sunroof is opened.

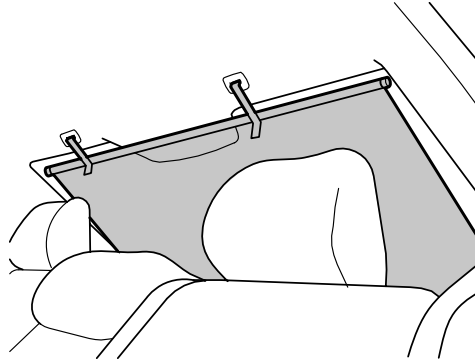

Sun blind - rear window

Pull the sun blind up from the parcel shelf and hook it into the holes above the rear window, as illustrated.

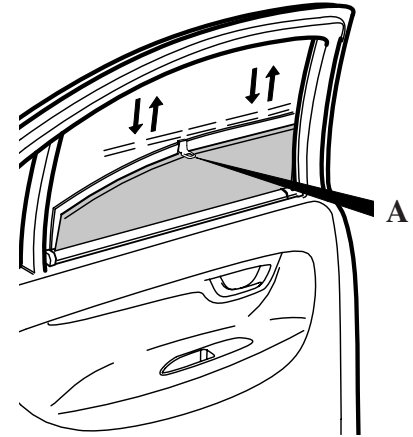

Sun blinds - rear side windows

Lower the window slightly. Hook the sun blind (A) onto the top edge of the window. You can now raise and lower the window as you wish.

Laminated front and rear side windows (option)

Inform the rear seat passengers of the following:

Due to the refraction of light through the side windows, rear seat passengers may find angles and distances distorted when looking **through the front side window on the same side as they are sitting.**

Laminated side windows give you extra protection against attempted break-ins.

Climate control

Air distribution	46
Useful hints	47
Electronic Climate Control ECC	48
Manual climate control with air conditioning (A/C)	52
Manual climate control without air conditioning (A/C)	54
Parking heater	56

Air distribution

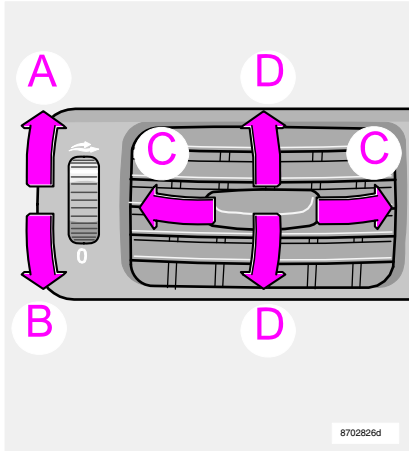

Air vents in the dashboard

Air vents in the dashboard

- A Open
- B Closed
- C Directing airflow laterally
- D Directing airflow vertically

- Aim the outer vents towards the side windows to remove misting.
- In cold climates: close the centre vents for the most comfortable climate and best demisting.

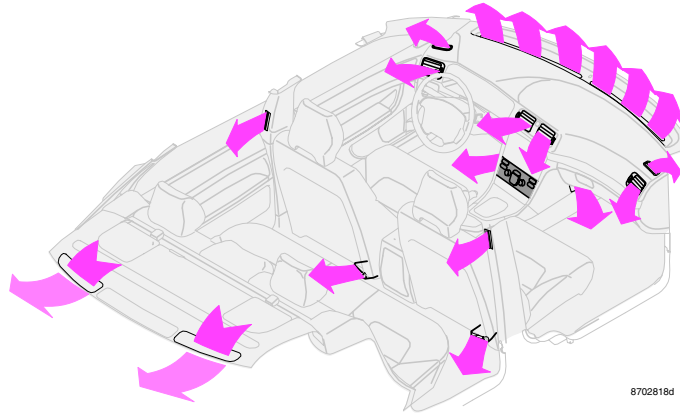

8702818d

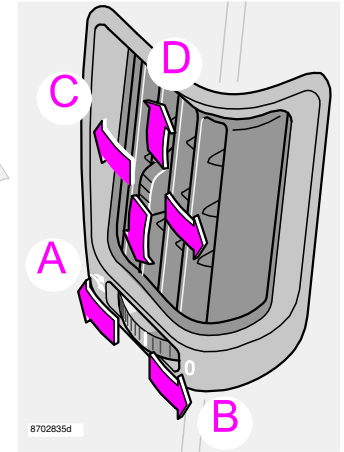

8702835d

Air vents in the door pillars

Air vents in the door pillars

- A Open
- B Closed
- C Directing airflow laterally
- D Directing airflow vertically

- Aim the vents toward the rear side windows to remove misting.
- Aim the vents inwards into the car if you wish to have a comfortable climate in the rear seat.
- Bear in mind that small children are sensitive to airflow and draughts.

Your climate control system - useful hints

Misting on window interiors

A good way to reduce the problem of misting on the insides of the windscreen and other windows is to clean them. Use a normal window cleaner. Bear in mind that you must clean them more often if someone smokes in the car.

Ice and snow

Remove ice and snow from the climate control air intake (the grille between the bonnet and the windscreen).

Particle filter

Make sure the particle filter is replaced regularly. Consult your Volvo workshop.

Actual temperature - ECC

The temperature you select corresponds to the physical experience with reference to air speed, humidity, exposure to sun, etc. which affect the interior and exterior of the car.

Sensors - ECC

The sun sensor is on the upper portion of the dashboard. Remember not to cover it. Do not cover the passenger compartment temperature sensor on the climate control panel.

When it is hot outside - sun heated car

In order to cool the car more rapidly when it is very hot outside you can "air" the car at the beginning of your journey by opening the windows and sunroof for a short time. This assists the car to cool the interior.

Side windows and sunroof

For the air conditioning (A/C) system to operate satisfactorily the side windows and sun roof should be closed. Also, remember not to block the evacuation channels in the parcel shelf.

Acceleration

The air conditioning system switches off temporarily at full acceleration. You may feel a temporary rise in temperature.

Condensation / After Blow

In warm weather conditions condensation from the air conditioning (A/C) system may drip under the car. This is completely normal. If necessary, the fan starts 50 minutes after the ignition key is switched off and dries the climate control system for seven minutes. The fan will afterwards switch off automatically.

Fault tracing

Your Volvo workshop has the instruments and tools required for any fault tracing or repair of your climate control system. Entrust checks and repairs only to trained personnel.

Environmental care

Refrigerant R134a is in the air conditioning system. This contains no chlorine, which means it is harmless to the ozone layer. Use only R134a when topping up/refilling refrigerant. This work should be performed by an **accredited workshop**.

Electronic Climate Control ECC

*Recirculation/Interior Air Quality System
(Interior Air Quality System)*

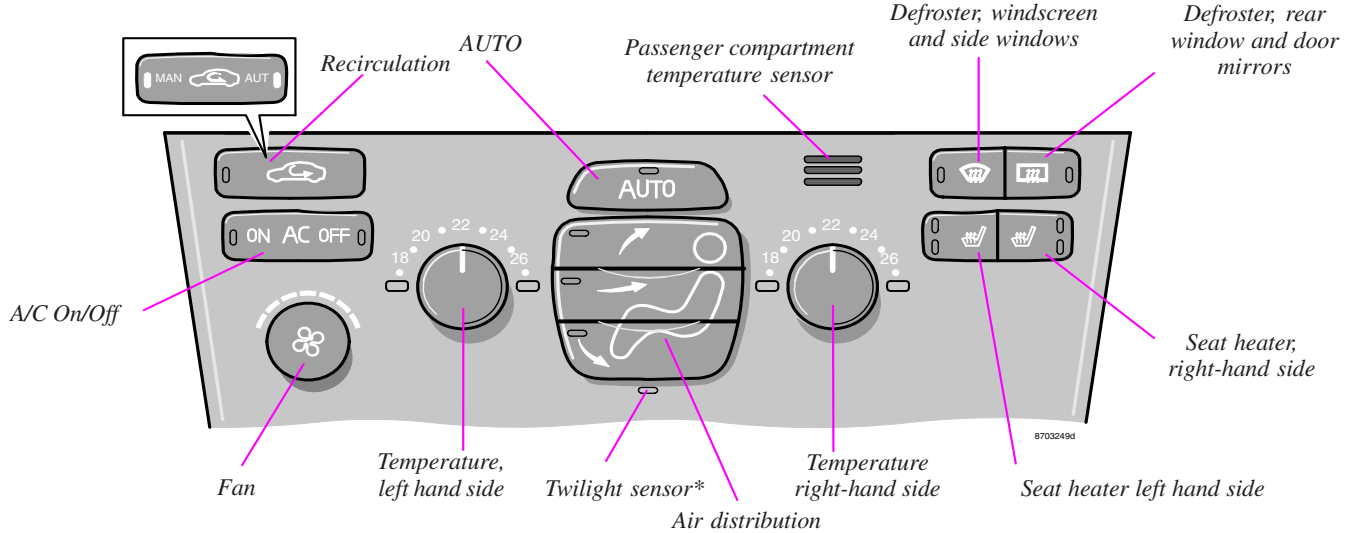

* Automatically adjusts all instrument lighting.

Electronic Climate Control ECC with Interior Air Quality system (option)

Multifilter with

Air quality sensor (option)

Some cars are equipped with a multifilter and air quality sensor. The multifilter separates gases and particles, thus reducing the volume of odours and contaminants entering the car. The air quality sensor detects increased levels of contaminants in the outside air. When the air quality sensor detects contaminated outside air, the air intake is closed and the air inside the compartment is recirculated. The multifilter also cleans the air recirculating in the compartment.

When the air quality sensor is connected, the

green *AUT* LED lights in .

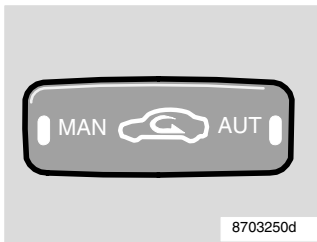



Operation:

Press  to activate the air quality sensor (normal setting).

Or select one of three functions by

pressing .

1. Press : the LED *AUT* lights. The air quality sensor is now activated.

2. Press : no LED lights. Recirculation is not activated unless needed to cool.

3. Press : the LED *MAN* lights. Recirculation is now activated.

You can switch between these three functions

by repeatedly pressing .

Keep in mind the following:

- Make it a rule to have the air quality sensor activated at all times.
- Recirculation is limited in cold climates to avoid misting.
- In the event of misting, you should disconnect the air quality sensor.
- In the event of the windows misting up you can use the windscreen and side window defroster functions. See next page.
- The recommended interval for changing the multifilter is at every other scheduled service. The Multifilter may need to be changed more often if you drive in heavily polluted environments.

Electronic Climate Control ECC

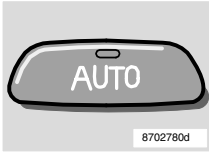

AUTO

The **AUTO function** regulates climate control so that the selected temperature is attained. The automatic function controls heating, air conditioning, fan speed, recirculation and air distribution. If you select one or more functions manually, the other functions continue operating automatically. All manual settings are switched off when **AUTO** is switched on.

Fuel economy - Electronic climate control ECC

With ECC, the air conditioning system is controlled automatically and is used just enough to cool the passenger compartment and dehumidify the incoming air. This provides better fuel economy compared to conventional systems where the air conditioning cools the air to just above freezing point.

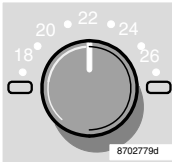

Temperature

The two knobs can be used to set the temperature for the passenger and driver's sides of the car. Remember that it will not heat or cool any quicker even if you select a higher or lower temperature than you wish to have in the passenger compartment.

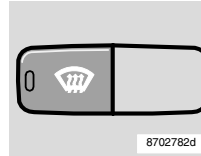

Defroster - windscreen and side windows

Use this button to quickly remove misting and ice from the windscreen and side windows. The air flows to the windows at high fan speed. The LED in the defroster button lights when this function is activated. The air conditioning system is now controlled so that the air is maximally dehumidified. The air is not recirculated.

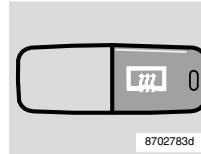

Defroster - rear window and door mirrors

Use this button to quickly remove ice and misting from the rear window and door mirrors. See page 38 for more information about this function.

Electronic Climate Control ECC - manual settings

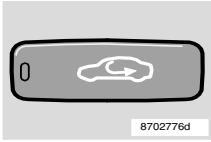



Recirculation

(see also page 49)

The best cooling in warm climates is achieved by selecting the **AUTO function**.

The recirculation is then controlled automatically. Manual recirculation can be selected if you wish to shut out bad air, exhaust fumes etc. The air in the passenger compartment is recirculated; no air from outside the car is taken into the car when  is activated. The LED in the switch is lit.

If you allow the air in the car to recirculate there is a danger of misting and icing in the car, especially during the winter.

The timer function (cars with multifilters and air quality sensors have no timer function) minimises the risk of ice, misting and bad air. Carry out the following to activate it. Press  for more than 3 seconds. The LED flashes for 5 seconds. The air in the car recirculates for 3-12 minutes depending on the outer temperature. Each time you press  the timer function is activated. If you wish to switch off the timer function, press  again for more than 3 seconds. The LED lights for 5 seconds to confirm your selection.

If you select **Defroster** , recirculation is always disconnected.

Air distribution

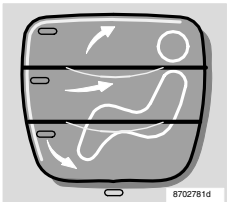

Air to windows.

Air to head and body.

Air to legs and feet.

Press **AUTO** to return to automatic air distribution.

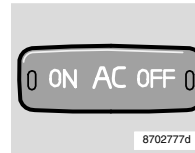

A/C - ON/OFF

When the ON LED lights the air conditioning (A/C) system is controlled automatically by the system. In this way incoming air is cooled and moderately dehumidified. When AC OFF is selected and the OFF LED lights the air conditioning (A/C) system is always disconnected, other functions are still controlled automatically. The air conditioning (A/C) system operates down to approximately 0°C.

When you select **Defroster** , the air conditioning system is controlled so that air is maximally dehumidified.

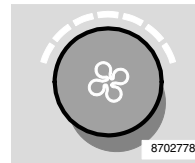

Fan

Fan speed can be increased or decreased by turning the knob. If **AUTO** is selected, fan speed is controlled automatically. The previously set fan speed is disconnected.

NOTE! If the knob for the fan has been turned so far that the left LED above the knob lights up with an orange light, the fan and the air conditioning (A/C) system are switched off.

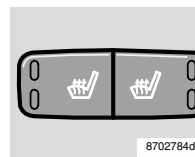

Heating the front seats

See page 38 for more information



Manual climate control with air conditioning AC

Recirculation



8702776d

Recirculation, together with your air conditioning (A/C) control, helps to cool a warm cabin more quickly. This function can also be used to exclude bad air, exhaust fumes etc. The air in the passenger compartment is recirculated; no air from outside the car is taken into the car when the button  is activated. The LED in the switch is lit. If you allow the air in the car to recirculate there is a danger of misting and icing in the car, especially during the winter.

The **timer function** minimises the risk of ice, misting and bad air. To activate the function: press  for more than 3 seconds. The LED flashes for 5 seconds. The air in the car recirculates for 3-12 minutes depending on the outer temperature. Every time you press  the timer function is activated. If you wish to switch off the timer function, press  again for more than 3 seconds. The LED lights for 5 seconds to confirm your selection.

Recirculation is always disconnected when you select **Defroster** .

A/C - ON/OFF



8702777d

The air conditioning is connected to the **cooling and dehumidification function** when the ON LED lights.

The air conditioning is disconnected with the OFF LED lights.

When you select Defroster , the air conditioning is always connected, unless the fan is set at position 0.

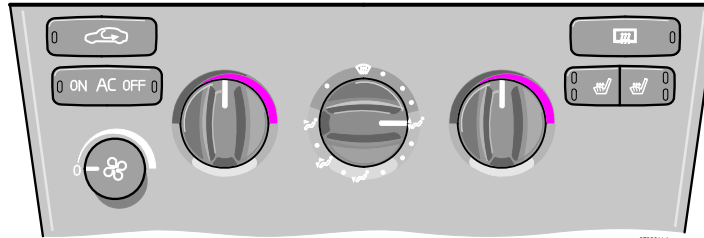

8702811d

Fan

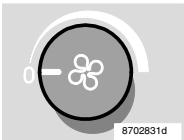

8702831d

Fan speed can be increased or decreased by turning the knob. If the knob is set to 0, the air conditioning is disconnected.

Heating/Cooling - left side

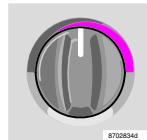

8702834d

Turn to adjust the heating or cooling of the incoming air. The air conditioning must be connected to receive cooled air.

Heating/Cooling - right side

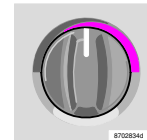

8702834d

Turn to adjust the heating or cooling of the incoming air. The air conditioning must be connected to receive cooled air.



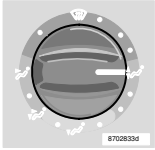

Manual climate control with air conditioning A/C



Use the air distribution control positions (marked with dots) between the different symbols to fine-tune air distribution for maximum comfort.

Air distribution

Use...

 <p>Air through front and rear air vents.</p>	<p>When you want good cooling in a warm climate.</p>
 <p>Air to windows In this position the air does not recirculate. The air conditioning (A/C) system is always connected. There is a certain amount of airflow to the vents.</p>	<p>When you want to remove ice and misting. High fan speed is good for this.</p>
 <p>Air to both floor and windows. There is a certain amount of airflow to the air vents.</p>	<p>When you want comfortable conditions and good demisting in a cold climate. Not too low a fan speed.</p>
 <p>Air to floor. There is a certain amount of airflow to the air vents and the defroster vents for the windscreen and side windows.</p>	<p>When you want to warm your feet.</p>
 <p>Air to floor and air vents.</p>	<p>In sunny weather with cool outside temperature.</p>

Here is some supplementary advice and information:

- You must turn the fan knob (from the 0 position) to connect the air conditioning.
- Use the air conditioning at low temperatures (0 - 15 °C) to dehumidify incoming air.

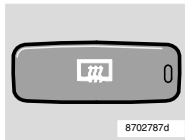

Defroster - rear window and door mirrors

Use this button to quickly remove ice and misting from the rear window and door mirrors. See page 38 for more information about this function.

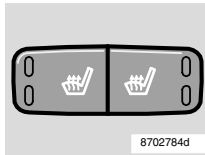

Heating the front seats

See page 38 for more information.

Parking heater (option)

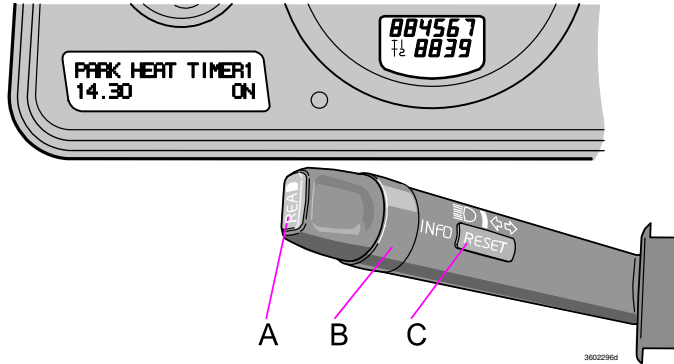

Short push on RESET (C)

Setting of hours and minutes

Long push on RESET

The timer is activated (ON)

Long push on RESET

The timer is turned off (OFF)

ON lamp lights with a steady glow

The timer is activated

The ON lamp flashes

The parking heater is activated

The parking heater can be started immediately or set to two different start times using TIMER 1 and TIMER 2.

Here, start time refers to the time point the car should be completely warmed up.

Vehicle electronics calculates start time based on current outside temperature. If the outside temperature exceeds 25°C, heating is not switched on.

At temperatures of -7°C and below, the parking heater runs a maximum of 60 minutes.

If repeated attempts to start the parking heater are unsuccessful, an error message is shown in the display - contact a Volvo workshop.

The car must be outdoors

Remember that the car must be outdoors when using petrol and diesel heaters.

Parking on a hill

If you park your car on a steep incline, the front of the car should be facing up the slope to ensure the supply of fuel to the parking heater.

Direct start of heater

1. Use the thumb wheel (B) to select DIRECT START.
2. Press the RESET button (C) to make ON and OFF selections available.
3. Select ON. The heater will now run for 60 minutes. Heating of the passenger compartment will begin as soon as the engine coolant has reached a temperature of 20°C.

Deactivation of heater after direct start

1. Use the thumb wheel (B) to select DIRECT START.
2. Press the RESET button (C) to make ON and OFF selections available.
3. Select OFF.

Parking heater (option)

Setting TIMER 1 or 2

For reasons of safety, you can only programme times for the following 24 hours, not several days in a row.

1. Use the thumb wheel (B) to select TIMER 1.
2. Briefly press the RESET button (C) so that the hours setting starts to flash.
3. Use the thumb wheel to set the desired number of hours.
4. Briefly press the RESET button so that the minutes setting starts to flash.
5. Use the thumb wheel to set the desired number of minutes.
6. Briefly press the RESET button to confirm your setting.
7. Press the RESET button to activate the timer.

Once you have set TIMER 1, you can toggle to TIMER 2. Make settings the same way as for TIMER 1.

Deactivation of timer-started heater

Do as follows to manually switch off the heater before the set time has elapsed:

1. Press the READ button (A)
2. Use the thumb wheel (B) to scroll to the text PARK HEAT TIMER 1 or 2. The text ON flashes.
3. Press the RESET button (C). The text OFF is displayed with a steady glow and the heater is switched off.

Messages in the display

Once TIMER 1, TIMER 2 or DIRECT START is activated, the amber warning symbol in the combined instrument panel lights and explanatory text is shown in the display.

When you leave the car, you will receive a message regarding the current settings of the system.

Car clock/timer

For reasons of safety, all timer settings will be cleared if the car clock is reset after timer settings have been made.

Battery and fuel

If the battery is not sufficiently charged or the petrol tank is close to empty, the parking heater will be switched off.

If this is the case, you will receive a message in the display. Confirm the message using the READ button (A).

Important!

Repeated use of the parking heater combined with only short journeys can discharge the battery and impair starting.

In order to ensure that the generator receives sufficient time to produce the amount of energy needed without discharging the battery as a result of regular heater use, drive the car for a period equalling the time during which the heater has been active.

Interior

Front seats	58
Interior lighting	60
Storage compartments	62
Centre console storage compartments, Load curtain	63
Spare wheel, Warning triangle	64
Long loads	65
Coat hanger	66

Front seats

Height adjustment - front seat

The front edges of the driver's and passenger seats can be adjusted to seven different settings and the rear edges to nine different settings.

The front lever - (A) adjusting the front edge of the seat.

The rear lever - (B) adjusting the rear edge of the seat.

Lumbar support

Softer

Harder

Move the seat backwards in order to operate the lumbar support adjustment knob more easily!

Front-rear adjustment

The seat can be moved forward or backward when the bracket is lifted.

Check that the seat has locked into position after adjusting.

WARNING!



Adjust the seat before you begin driving.

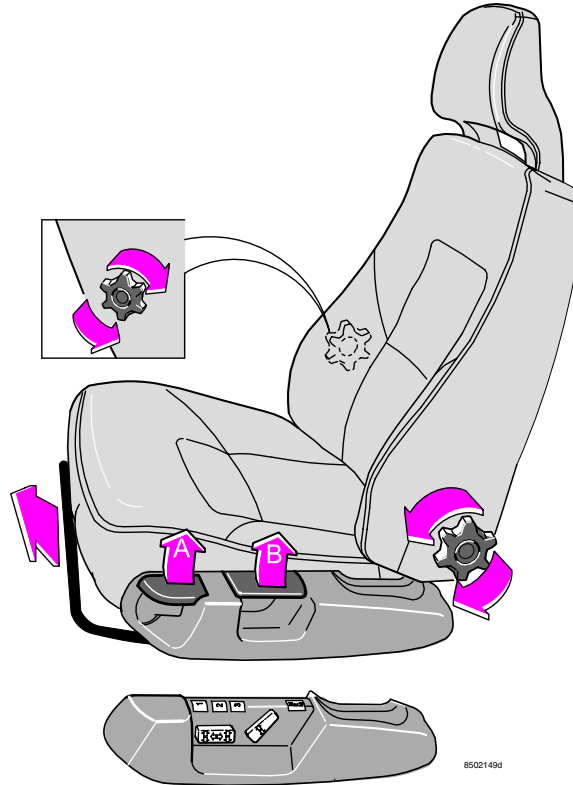

Backrest rake

Clockwise - backward

Anticlockwise - forward

Electrical operation centre

Folding the front passenger seat, Rear seat head restraints

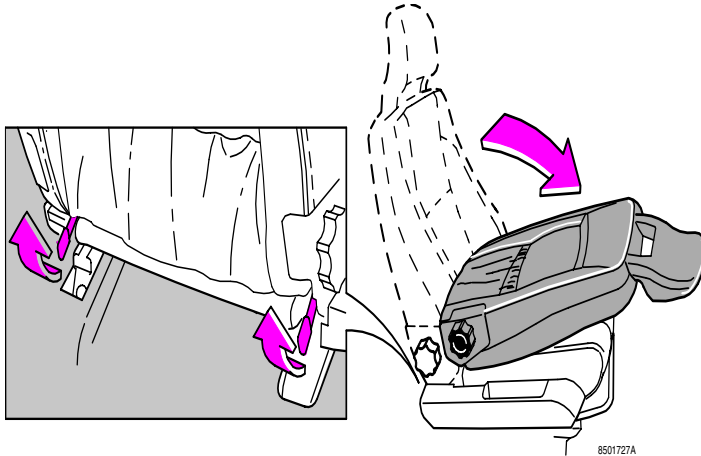

Folding the front passenger seat

The front passenger seat backrest can be folded to a horizontal position to make room for a long load. Fold the backrest as follows:

- Move the seat as far back as possible.
- Adjust the backrest to the upright position.
- Lift the catches on the rear of the backrest.
- Fold the backrest forward.

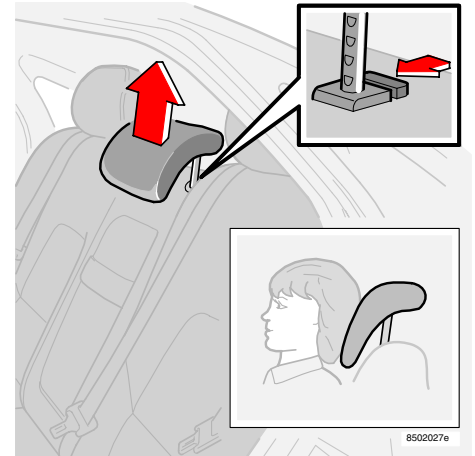

Adjust the head restraint vertically

Rear seat head restraints

The centre seating position head restraint is adjusted vertically according to the height of the passenger. Press the head restraint up or down as necessary. To move the head restraint up or down, you must press the release button behind the left-hand support. See illustration.

If the integrated booster cushion is used, the head restraint must be carefully positioned to suit the child.

Front seats

Power seat (option)

If your Volvo is equipped with power seats, the following may be adjusted with the two switches at the side of the seat:

- A - Height of seat front edge
- B - Front - rear
- C - Height of seat rear edge
- D - Backrest rake

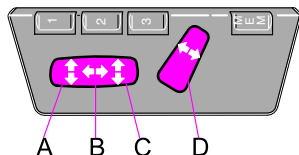

NOTE! The power seats have an overload protector which activates if the seat is blocked by any object. If this occurs switch off the ignition (ignition key in position 0) and wait for 20 seconds before using the seat again.

Emergency stop

If the seat accidentally begins to move, press one of the buttons to stop the seat.

Seats with memory function (option)

Three positions can be stored. After setting the position hold the MEM button (H) depressed, while depressing button E. Further seat and door mirror settings can be stored in the memory using memory buttons F and G.

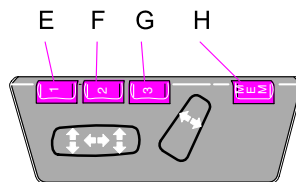

Setting preset positions

Hold one of the buttons E, F or G depressed until the seat and door mirrors stop.

If one of the setting buttons is released the seat will, for safety reasons, stop moving.

Ignition key

Passenger seat: The seat can only be adjusted if the ignition key is in position I or II.

Driver's seat: The seat can be adjusted if the ignition key is in position I or II. It can also be adjusted in the following circumstances:

1. Within 40 seconds of the ignition key being turned to position 0 or removed from the ignition switch.
2. After you have unlocked the driver's door with the key or remote control, the driver's seat can be adjusted during a 10 minute period **if the door remains open**. If the door is closed, the seat can be adjusted for 40 seconds. The ignition key can be in position 0 or not yet inserted in the ignition switch.

Storing seat positions in the remote control

Unlocking the car with one of the remote controls and changing the driver's seat settings, causes the new position to be saved in the remote control. The next time the car is unlocked with the same remote control and the driver's door is opened within two minutes, the driver's seat will assume the saved position.

WARNING!



When adjusting, ensure that there are no objects in front of or behind the seat. Ensure that none of the rear seat passengers will be pinched. To avoid this possibility, ensure that children do not play with the switches.

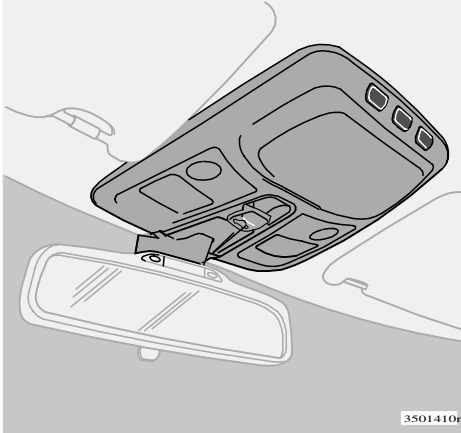

General lighting and front reading lamps



Rear reading lamps

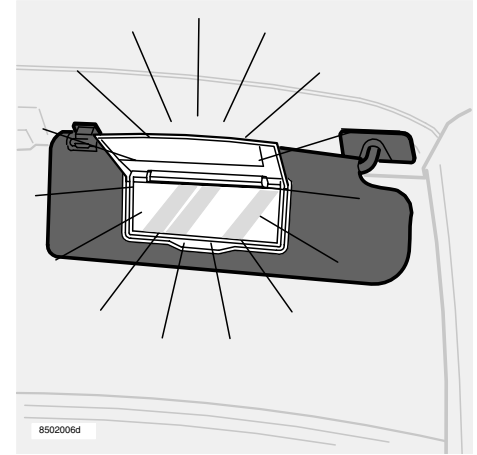

Vanity mirror in the sun visor

General lighting

General lighting lights up and goes out when you press the button. The general lighting has a built-in automatic function which means that the general lighting lights up and remains lit for 30 seconds:

- When you unlock the car from the outside using the key or remote control.
- When you have stopped the engine and turned the ignition key to position 0.

General lighting lights up and remains lit for 10 minutes:

- When one of the doors is open.

General lighting goes out:

- When the engine is started.
- When you lock the car from the outside using the key or remote control.

General lighting can be switched off or on in all situations by briefly pressing the button.

When you switch the light on, it remains lit for 10 minutes.

You can disconnect the automatic function by pressing the button for more than 3 seconds.

When you then briefly press the button, the automatic function reconnects.

The pre-programmed times of 30 seconds and 10 minutes can be changed. Contact an authorised Volvo workshop.

Front and rear reading lamps

Reading lamps in the front and rear seats can be switched on or off by pressing the respective button. Reading lamps are switched off automatically after 10 minutes if not switched off manually.

Vanity mirror

The lamps come on when you open the cover.

Storage compartments

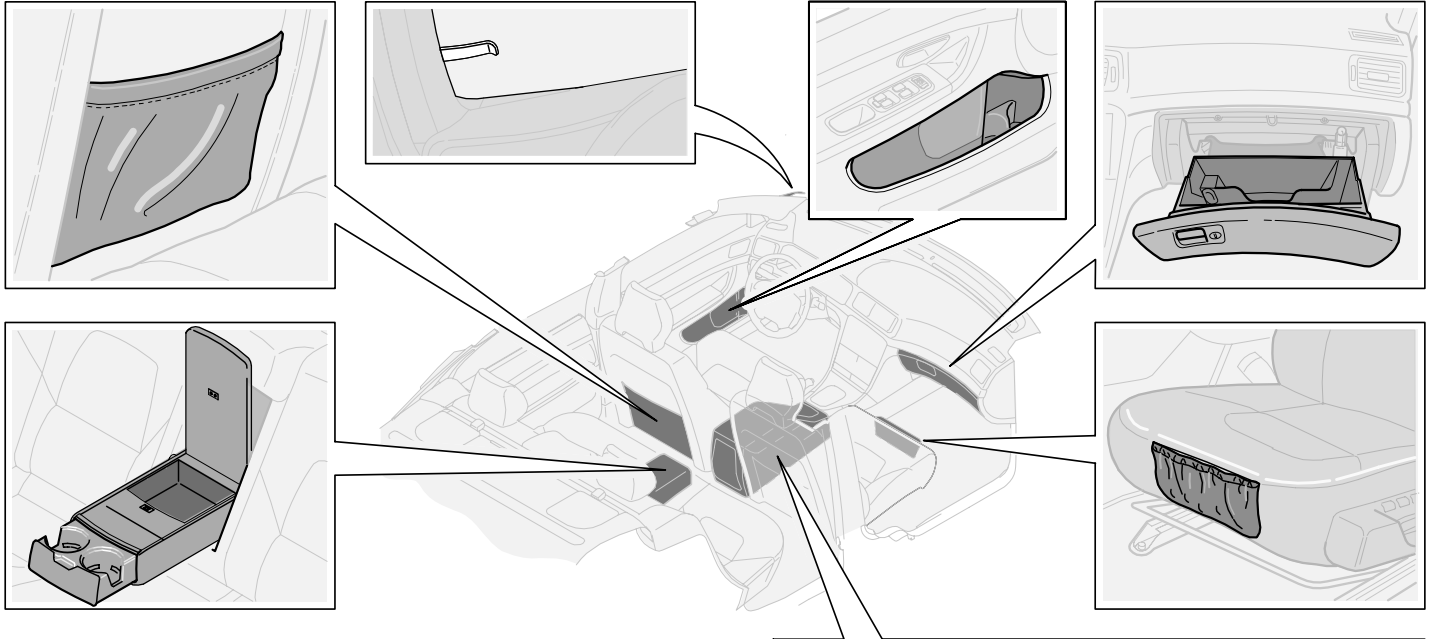

WARNING!



Make sure that no hard, sharp or heavy objects lie on or in (or protrude from) the parcel shelf, map pocket or other storage compartments where they might cause injury during heavy braking. Always fasten large heavy objects with one of the seat belts.

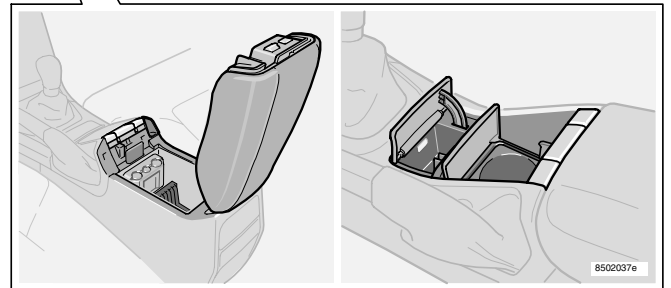

Centre console storage compartments, Load curtain

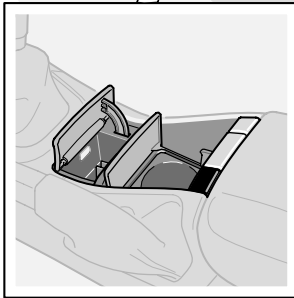
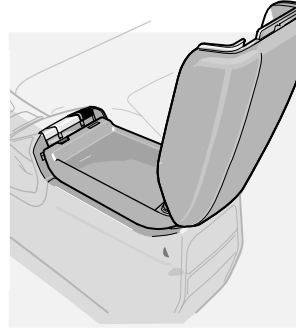
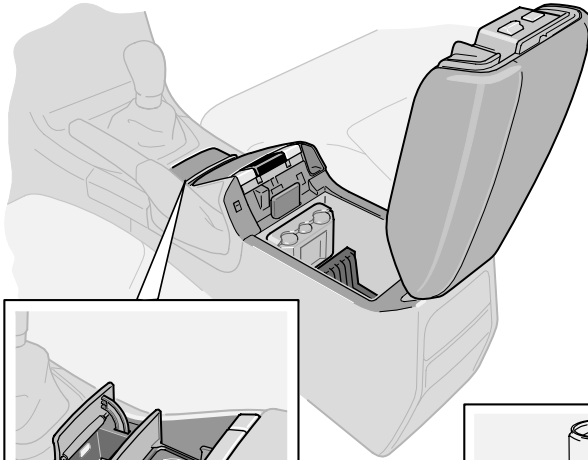

8502003d

Ashtray (option)

To empty the ashtrays:

Front seat: pull the ashtray straight upwards.
Rear seat: press the ashtray downwards and remove.

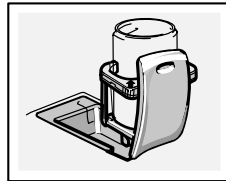

Cup holder (option)

Some models are equipped with cup holders for the front and rear seat occupants. To open the cup holders in the front seats, press the left-hand button in the centre console to open the driver's cup holder and the cover below to open the passenger-side cup holder. To close the passenger-side holder after use, the arms must be pressed inwards as indicated by the arrows on the holder. You can also use the storage compartment in the centre console for cassette tapes and the like.

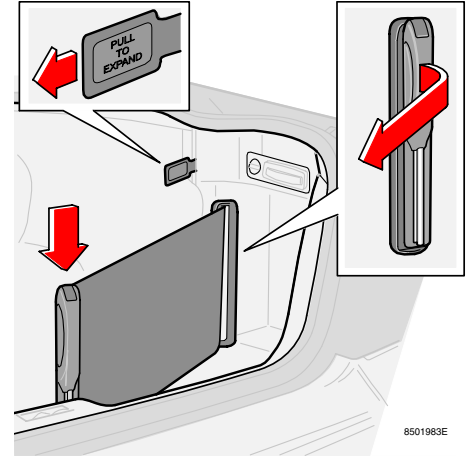

8501983E

Load curtain in cargo compartment (option)

The load curtain can be used to secure lighter objects, such as grocery bags. Pull out the curtain. It works in the same way as a seat belt and has a locking function.

To release the curtain from the locked position, pull the release tab and pull out the curtain.

The expanded curtain can be fixed in two positions. When securing the curtain in position, press until it clicks into place.

NOTE! If you have an extra plastic mat with edges that go up along the sides of the cargo compartment, you must cut a groove in the mat so that the load curtain can run freely.

Spare wheel, Warning triangle

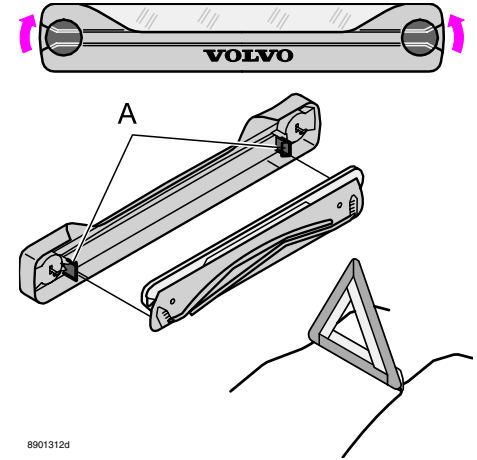
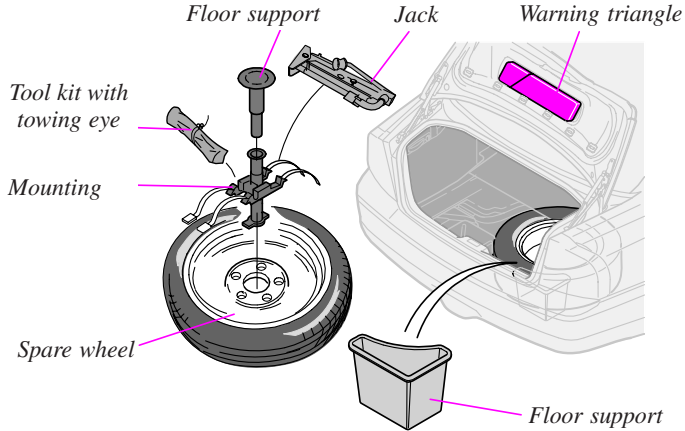

Spare wheel, tools, jack

The spare wheel with the jack and tool kit can be found under the floor of the cargo compartment. Carry out the following to remove the spare wheel:

- Fold the floor inwards.
- Lift and remove the floor support that sits in the spare wheel mounting. Cars with a “Temporary Spare” also have a floor support in the rear left-hand corner of the cargo compartment. Pull the support upwards to facilitate removing the spare wheel.
- Lift out the jack and tool kit.
- Unscrew the mounting and lift out the spare wheel.
- Return and secure everything in the reverse order. Make sure that the spare wheel is fixed in place and that the jack and tool kit are properly secured with the straps on the mounting.

Warning triangle (certain countries)

Follow the regulations concerning warning triangles of the country you are in. Carry out the following when the warning triangle is required for use:

- Turn both attachment screws to the vertical position.
- Carefully remove the warning triangle case.
- Remove the warning triangle from its case (A).
- Fold out the four support legs on the warning triangle.
- Fold out and secure the two remaining sides of the warning triangle.
- Place the warning triangle in a suitable position. Think about the position of the car and the traffic.

After use:

- Pack everything in reverse order.
- Make sure the warning triangle and its case are properly secured in the boot lid.

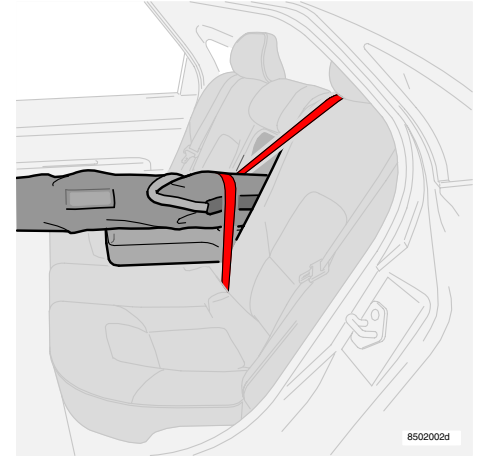
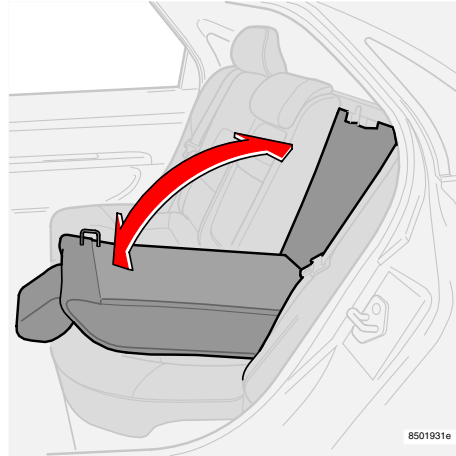
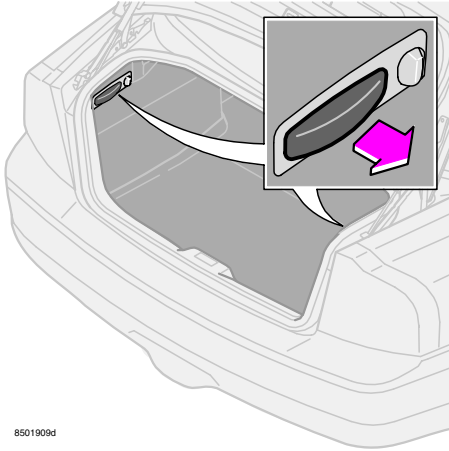

Always secure long loads!

Tipping the backrests forward

One or both of the rear seat backrests can be folded down from the cargo compartment for transporting long objects. Pull the handle(s) in the cargo compartment. The head restraints must be in the upright position. Then tip the backrest or backrests forward. The centre head restraint may need to be adjusted. When raising the backrests, ensure that they are properly secured and locked.

Ski hatch

A hatch in the rear backrest allows long objects (skis, planks, etc.) to be transported. To open this hatch, tip the right-hand backrest forward. Release the hatch by pushing the catch upwards at the same time as folding the hatch forward. Then tip the backrest back into position with the hatch open.

NOTE! If your Volvo is equipped with an integrated booster cushion, you must fold this out first.

WARNING!



Always secure the load. During heavy braking the load may otherwise shift, causing personal injury. Cover sharp edges with something soft. Turn off the engine and apply the parking brake when loading or unloading long objects! You may accidentally knock the gear lever or gear selector with the load and cause a gear to engage and the car to move off.

Coat hanger

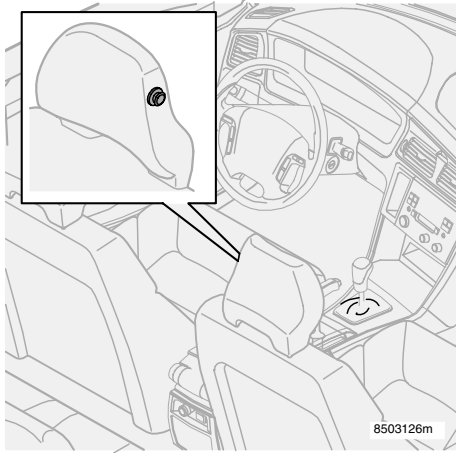

Coat hanger

Use the coat hanger for clothes of normal weight.

Locks and Alarm

Immobilizer, remote control	68
Locking and unlocking	69
Replacing the battery	70
When it is dark, deadlocks	71
Child safety lock	72
Alarm	73

Doors and locks

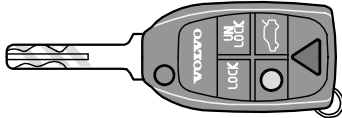
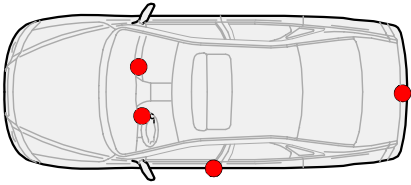

Master key

This key operates all locks

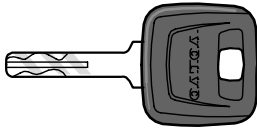
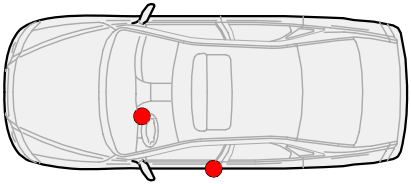

Service key*

For driver's door, ignition switch and steering wheel lock only.

8302189d

*: certain markets only

Keys - Immobilizer

Your car is delivered with two master keys and one service key*. One of the master keys is foldable and equipped with an integrated remote control.

Loss of key

If you should lose one of your keys, bring the remaining keys to an authorised Volvo workshop. As a crime prevention measure, the code for the lost key is erased from the system and the other keys must be re-coded in the system. The mechanical code numbers for the keys are recorded on a separate label accompanying the keys. Store the label in a safe place. Take the label to your Volvo dealer if you wish to order new keys. A maximum of six remote controls/keys can be programmed and used.

Immobilizer

Each key has an integrated coded chip. The code must be the same as the code in the ignition switch receiver. The car can only be started if the correct key with the correct code is used.

Remote control functions

1. Unlocking

Button (1) unlocks all doors, boot lid and fuel filler flap.

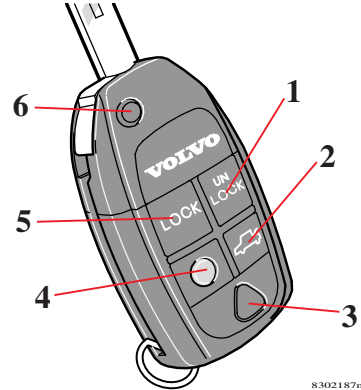

8302187e

1. Unlock 2. Open boot lid
3. Alarm function 4. Approach lighting
5. Lock 6. Fold/open key

2. Boot lid

Press button 2 to unlock the boot lid only.

3. Alarm function

The alarm function can be used to attract attention during emergency situations. If the red button (3) is held for at least 3 seconds or is pressed twice in succession during the same amount of time, the direction indicators and horn will be activated. The alarm can be deactivated with any of the remote control buttons or it will shut off automatically after 25 seconds.

Locking and unlocking

4. Approach lighting

Do the following when you approach the car:

Press the yellow button (4) on the remote control.

The interior lighting, parking lamps, number-plate lighting and the lamps in the door mirrors (option) will switch on. If a trailer is attached to the car, the trailer lights will also be switched on. These lights will remain lit for 30, 60 or 90 seconds. An appropriate time setting for your car can be performed at an authorised Volvo workshop.

In order to switch off Approach lighting: press the yellow button again.

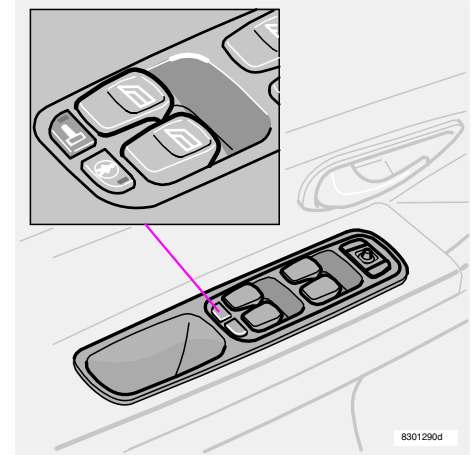
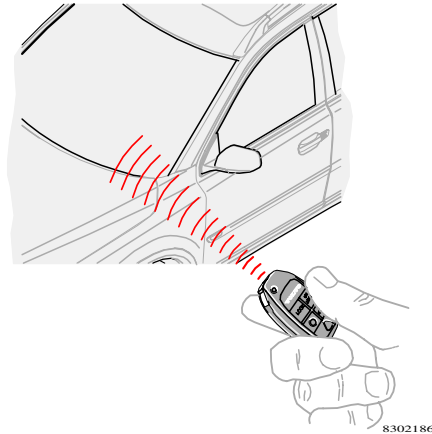

5. Locking

Lock all doors, boot lid and fuel filler flap with button 5. There is a delay of approx. 10 minutes for the fuel filler flap.

6. Folding/opening key

The key can be folded by pressing button 6 while folding the key blade into the keypad. The folding key will open automatically with one press of the button.

Locking and unlocking the car from the outside

Using the master key or its remote control, all the doors and the boot lid can be locked or unlocked from the outside at the same time. When the vehicle is locked, the door locking buttons and interior door handles are disconnected.

Using the master key or its remote control, all the doors and the boot lid can be unlocked from the outside at the same time.

If the car is locked from the outside, the fuel filler flap locks after a 10-minute delay.

Locking and unlocking the car from the inside

All doors and the boot lid can be locked and unlocked at the same time using the switches in the door panel (applies if the vehicle is opened with the master key).

All doors can also be unlocked and locked using the lock buttons. The above situation is valid, as long as you haven't locked the car from the outside!

If the car is locked from the inside using the switches in the door panel, the fuel filler flap remains unlocked.

Automatic relocking

If none of the doors or the boot lid is opened within two minutes of being unlocked **with the remote control from the outside**, all locks will be automatically relocked. This function prevents you from inadvertently leaving the car unlocked.

For cars with an alarm, see page 73.

NOTE! If the boot lid was opened with the button on the remote control, it will not automatically relock.



Locking, unlocking and opening the boot lid with the remote control

Normally the boot lid is locked or unlocked when you lock or unlock the car using the master key in the driver's door or the remote control. If you wish only to unlock or open the boot lid, press the button on the remote control. So that the boot lid is not unlocked accidentally you must: press the button **slowly** twice within three seconds. The boot lid then opens. If all the doors are locked when you later close the boot lid, it will be automatically locked.

Unlocking the boot lid with the master key

Normally the boot lid is locked or unlocked when you lock or unlock the car using the master key in the driver's door or the remote control. The boot lid can be opened by **slowly** pressing the button on the remote control twice within three seconds, or by pressing the boot lid opener. The master key should only be used to unlock the boot lid in emergency situations (if the remote control is broken or if the car is without power). In such cases: insert the master key into the upper or lower part of the plug covering the lock. Twist the key upwards or downwards and remove the plug. Then unlock the boot lid.

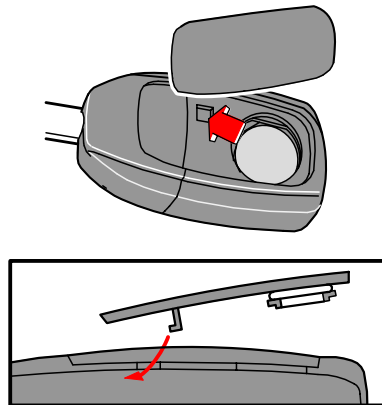

Replacing the battery

If the locks repeatedly fail to react to signals from the remote control at a normal distance, the battery should be replaced at the next service interval or within the course of a couple of weeks.

- Remove the cover by carefully prising up the rear edge with a small screwdriver.
- Change the battery (type CR 2032, 3 volt), the plus side should be up. Avoid touching the battery and its contact surfaces with your fingers.
- Refit the cover. Make sure the rubber seal is properly fitted and free from damage to prevent water from entering.
- Turn the old battery in to your Volvo workshop so that it is disposed of in an environmentally friendly way.

When it is dark, deadlocks

When it is dark

Approach lighting

Carry out the following **when you approach** the car:

- Press the yellow button on the remote control.

The interior lighting, parking lamps, number-plate lighting and lamps in the door mirrors now light (certain models).

Deadlocks

Your car has a special deadlock position which means that the doors cannot be opened from the inside if they are locked. Deadlocks can only be activated from the outside by the driver's door being locked with the key or remote control. All doors must be shut before the deadlock can be activated. The doors then cannot be opened from the inside. The car can only be unlocked from the outside via the driver's door or by using the remote control (this only applies to cars that are equipped with deadlocks). The car cannot be opened by manipulating the door buttons from the outside.

WARNING!

Do not allow anyone to remain in the car without deactivating the deadlock

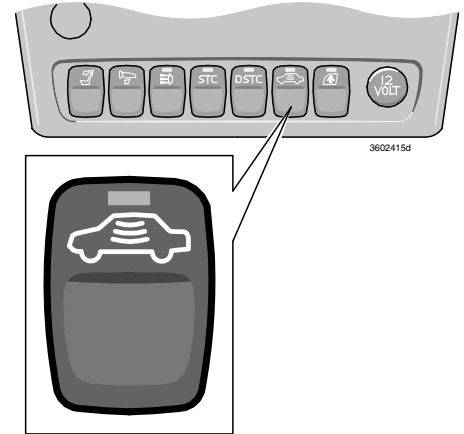

Deactivating deadlocks

If someone wishes to remain in the car but you still wish to lock the doors from the outside the deadlocks can be disconnected. From the time the key is turned from position II until you lock the car, or as long as the centre console is supplied with current, you can press the button. The LED in the button then comes on and stays on until you lock the car using the key or remote control. A message is displayed as long as the key remains in the ignition switch. The deadlock is now disconnected. The deadlocks will be re-activated the next time the ignition is switched on.

Child safety lock

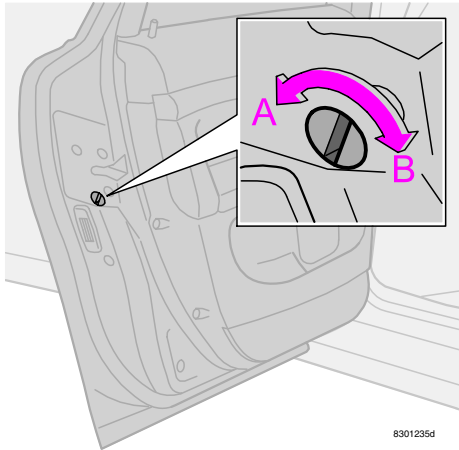

8301235d

Control for child safety lock - left rear door

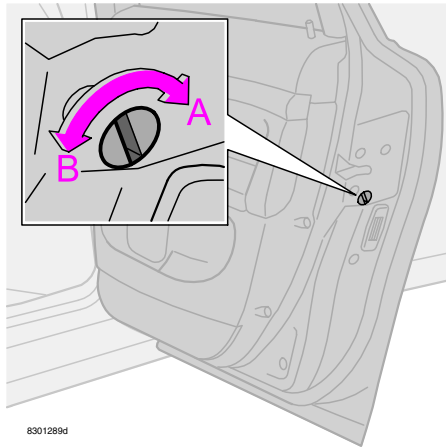

8301289d

Control for child safety lock - right rear door

Manual child safety locks - rear doors

The controls for the child safety locks are in the rear edges of the rear doors and are only accessible when the door is open. Use the ignition key to turn the control and thus activate or deactivate the child safety lock.

- A Door cannot be opened from the inside (twist outward).
- B The doors can be opened from the inside (twist inwards).

WARNING!



Remember that in the event of an accident, rear seat passengers cannot open rear doors from the inside if the child safety locks are activated. **Therefore, keep the doors unlocked while driving!** In the event of an accident, rescue personnel will then be able to quickly get into the car **from the outside**.

The alarm system (option)

When the alarm is connected, it continually monitors all alarm points.

The alarm is triggered if:

- the bonnet is opened.
- the boot lid is opened.
- a side door is opened.
- the ignition switch is turned with a non-approved key or subjected to force.
- a movement is detected in the passenger compartment (if a movement detector is installed - extra equipment).
- the car is lifted or towed away (if it is equipped with a tilt detector - extra equipment).
- the battery cable is disconnected.
- anyone tries to disconnect the siren.

Activating the alarm

Press the LOCK button on the remote control. A long flash signal from the car's direction indicators confirms that the alarm is active and that **all** doors are closed. In certain markets the key or the switch in the driver's door can be used to alarm the car.

Deactivating the alarm

Press the UNLOCK button on the remote control. Two short flash signals from the direction indicators of the car confirm that the alarm is deactivated. In certain markets, the key can be used to deactivate the alarm.

Deactivating a triggered alarm

Press the UNLOCK button on the remote control if the alarm sounds and you wish to deactivate it. Two short flashes of the direction indicators are given as confirmation.

Audio signal - Alarm

The audio signal is given from a siren with a reserve battery. Each alarm signal lasts 25 seconds.

Visual signal - Alarm

When the alarm is triggered, all direction indicators flash for 5 minutes and the car interior lighting lights for 5 minutes or until you deactivate the alarm as described above.

NOTE!

Even if your remote control does not work or you have lost it, you can start the car as follows: open the driver's door with the key. The alarm is triggered and the siren sounds. Start the car as usual. The alarm will then be deactivated.

Automatic alarm reset

If neither the side doors or rear door are opened within two minutes of the alarm being disarmed, and the car is unlocked with the remote control, the car automatically rearms the alarm. The car is simultaneously locked. This function prevents you from accidentally leaving the car unalarmed.

Status indicator lamp on the dashboard

An indicator lamp (LED) at the top of the dashboard gives a description of the alarm system status:

- Lamp not lit: Alarm is deactivated.
- Lamp flashes once a second: The alarm is activated.
- Lamp flashes quickly, after deactivating the alarm and until the ignition is switched on: The alarm has been triggered.
- If a fault has occurred in the alarm system, a message is shown in the display with instructions for appropriate measures.

IMPORTANT!

Do not attempt to repair or modify alarm system components. All such attempts can affect terms of insurance.

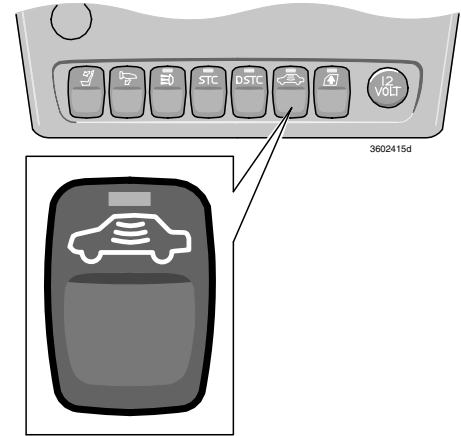

Temporary deactivation of detectors

To avoid triggering the alarm inadvertently, for example when leaving a dog in the car or during a ferry crossing, the movement and tilt detectors can be temporarily deactivated. The button can be pressed at any time between the key being turned from position II to the car being locked, or as long as the power to the centre console is on. The LED in the button lights until you lock the car with your key or remote control. A message is displayed as long as the key remains in the ignition lock. The detectors will be reactivated the next time you switch on the ignition. If your car is equipped with deadlocks, these will be simultaneously activated. See page 71.

Testing the alarm system

Testing the movement detector for the passenger compartment:

1. Open all windows.
2. Activate the alarm. Alarm activation is confirmed by the LED flashing slowly.
3. Wait 30 seconds.
4. Test the movement detector in the passenger compartment by lifting a bag or similar from the seat. The alarm should now sound and flash.
5. Deactivate the alarm by unlocking with the remote control.

Testing the doors:

1. Activate the alarm.
2. Wait 30 seconds.
3. Unlock with the key on the driver's side.
4. Open one of the doors. The alarm should now be triggered.
5. Repeat the test for the other door.
6. Deactivate the alarm by unlocking with the remote control.

Testing the bonnet:

1. Get into the car and deactivate the movement detector as described on page 74.
2. Arm the alarm (remain in the car and lock the doors with the button on the remote control).
3. Wait 30 seconds.
4. Open the bonnet with the handle under the dashboard. The alarm should now sound and flash.
5. Deactivate the alarm by unlocking with the remote control.

Testing the boot lid:

1. Activate the alarm.
2. Wait 30 seconds.
3. Unlock with the key on the driver's side.
4. Open the boot lid. The alarm should now sound and flash.
5. Deactivate the alarm by unlocking with the remote control.

If the alarm system does not work correctly, have the car examined by an authorised Volvo workshop.

Starting, driving, gearshifting

Fuel filler flap, Starting the engine	78
Economical driving	80
Manual gearbox	82
Automatic gearbox	83
All Wheel Drive	87
Active chassis, FOUR-C	87
Parking Assistance System	88
Towing	89
Jumpstarting	90
Driving with trailer	91
Towing bracket	93
Detachable towbar	95

Fuel filler flap, Starting the engine

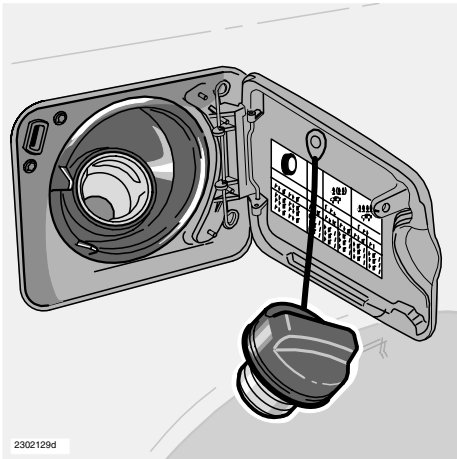

Refuelling

The fuel cap is inside the fuel filler flap on the right rear wing.

In high exterior temperatures there can be overpressure in the fuel tank. Open the filler cap slowly. Do not overfill the fuel tank. **A maximum of one automatic cut out by the fuel pump nozzle is recommended!** Too much fuel at high outside temperatures can cause the tank to overflow!

After refuelling, replace the fuel cap and turn until one or more clicks is heard.

Opening fuel tank

The fuel filler flap is unlocked and can be opened when the car is unlocked.

NOTE! When the car is locked from outside, the fuel filler flap remains unlocked for a further 10 minutes.

Start the engine as follows (Petrol)

- 1 Apply the parking brake (handbrake).
- 2 **Automatic gearbox:** Gear selector in P or N position.
Manual gearbox: Gear lever in neutral and the clutch pedal completely depressed. This is especially important in severe cold.
- 3 Turn the ignition key to the start position. If the engine does not start within 5-10 seconds, release the key and try again.

Refuelling

NOTE! Never add cleaning additives yourself unless specifically recommended to do so by a Volvo workshop.

Important!

Petrol-powered cars must always be refuelled with unleaded petrol so as not to damage the catalytic converter.

WARNING!



Always **switch off** your mobile telephone during refuelling - the ring signal can cause sparks which may ignite petrol fumes and lead to fires or personal injury.

Start the engine as follows (Diesel)

- 1 Apply the parking brake (handbrake).
- 2 **Automatic gearbox:** Gear selector in P or N position.
Manual gearbox: Gear lever in neutral and the clutch pedal completely depressed. This is especially important in severe cold.
- 3 Turn the ignition key to the driving position. A control symbol in the combined instrument panel shows that the engine is pre-heating. Turn the key to the start position when the indicator symbol has gone out.

Refuelling with diesel oil

At low temperatures (-5°C to -40°C) the diesel oil can precipitate paraffin, which makes the engine difficult to start. Make sure that special winter fuel is used during the cold period of the year.

NOTE! Depending on the engine temperature when starting, the idling speed with a cold start is - for a short period - higher than normal for some engine types.

The reason for this is Volvo's ambition to minimise exhaust emissions by bringing up the engine's exhaust purification system to its correct working temperature as quick as possible.

Immobilizer

Use the car key. Do not let several keys dangle next to each other from the same key ring when starting.

The new car - slippery road surface

Driving on a slippery road may feel different depending on whether you choose a car with a manual or an automatic gearbox. Practice handling skids under controlled conditions so that you know how your new car reacts.

Never rev the engine hard after a cold start!
If the engine fails to start or misfires, contact the nearest Volvo workshop.

Automatic gearbox safety systems

Cars with automatic gearbox have special safety systems:

Keylock - Ignition switch interlock

In order to move the gear selector from **P** position to other gear positions the ignition key must be in position I. In order to remove the ignition key after driving, the gear selector must be in the **P** position.

Shift lock

In order to move the gear selector from P position to the other gear positions when the key is in position I or II, the brake pedal must be depressed.

If you have started the engine and the car remains stationary:
hold your foot on the brake pedal when you move the gear selector to another position!

Automatic gearbox adaptive system

The gearbox is controlled by an "adaptive system". The control module continually "learns" how the gearbox behaves. It senses how the gearbox shifts gear and achieves optimal gear shifts each time. The control module also senses your driving style, such as how hard you depress the accelerator pedal, and adjusts the shift schedule to your specific driving style.

Automatic gearbox - Cold starts

When starting in low temperatures, gear shifts may feel harder. This is due to transmission oil viscosity at low temperatures.

To **minimise** engine emissions, the gearbox shifts up later than normal if the engine has been started at low temperatures.

When driving with a cold engine the gearbox shifts at a higher engine speed. This is done to faster attain the correct temperature for the catalytic converter.

Do not allow the engine and cooling system to overheat

Under certain conditions, e.g. when driving in hilly terrain and with a heavy load, especially in warm weather, there is a risk of the engine and cooling system overheating.

To avoid the cooling system overheating:

- Drive at low speeds if driving with a trailer up a long incline.
- Switch off the air conditioning temporarily.
- Avoid letting the engine idle.
- Do not turn the engine off immediately you stop, if the car has been driven hard.
- Remove any auxiliary lamps from in front of the grille if driving in extremely high temperatures.

To avoid the engine overheating:

Do not exceed engine speeds of 4500 rpm if driving with a trailer or caravan in hilly terrain. The oil temperature can become too high.

Drive with anticipation

Economical driving results from driving gently with anticipation and adapting your driving style and speed to the situation.

Keep in mind the following:

- Drive the engine to operating temperature as soon as possible! That is to say: do not let the engine idle, but drive with a light load as soon as you can.
- A cold engine consumes more fuel than a warm one.
- Avoid driving short distances where the engine never has time to reach operating temperature.
- Drive gently! Avoid unnecessary quick accelerations and heavy braking.
- Do not drive with unnecessary, heavy loads in the car.
- Do not drive with winter tyres when the roads are clear and dry.
- Remove the load carrier when it is not in use.
- Do not open side windows unnecessarily.

Select the right gear

An important part of driving economically is using the gearbox correctly. Select the right gear! Do not labour the engine!

Speed-dependent power steering

Your car can be equipped with speed-dependent power steering as an option. This means that the car is lighter to steer at low speeds, which

makes it easier to park, etc. As speed increases, the steering force will be adapted accordingly to give the driver better road feel.

Those of you who drive with trailers - here are some “special tips”

- When parking on slopes, you should apply the parking brake **before** moving the gear selector to P. When starting from a slope, first put the gear selector in drive and **then** release the parking brake.
- Select a low gear in the gearbox when driving on steep inclines or when driving slowly. This prevents the gearbox from upshifting if you have an automatic gearbox. The transmission oil will be cooler.
- If you have a Geartronic gearbox, do not use a higher manual gear than the engine can “handle”. It is not always economical to drive in high gears.

Driving characteristics and tyres

The tyres have great influence on the handling of the car. Both tyre type, dimension and tyre pressure are all important to how the car behaves. When you change tyres, ensure that you have the same type, size and brand of tyre on all four wheels. Also follow the recommendations as regards air pressure.

Do not drive with the boot lid open!

If you drive with the boot lid open, some of the exhaust gases and poisonous carbon monoxide could be sucked into the car through the cargo compartment. If you must drive a short distance with the boot lid open, do as follows:

- Close all windows.
- Distribute the air between the windscreen and floor while running the fan at high speed.

Car care

You should, of course, keep your car and especially the engine in good condition. Factors that can help you to keep fuel consumption down are:

- Good spark plugs
- Clean air filter
- Correct engine oil
- Brakes that are not constantly touching
- Correct wheel alignment
- Correct tyre pressure

Remember that the most important factor with regard to fuel consumption is you, and how you handle the accelerator pedal, break pedal and gear lever.

Some important tips!

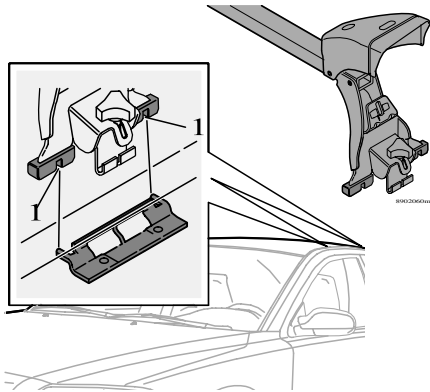

Load carrier attachment points

Fitting the load carriers

1. Make sure the load carrier is placed in the right direction (see the marking on the decal under the cover).
2. Fit the guide pins into the guide holes (1).
3. Carefully lower the bracket on the other side to the roof.
4. Screw the knob up a bit.
Press the knob against the roof bracket catch the hook **in the roof bracket** under the roof rail.
5. Screw the load carrier in place.
6. Fit the guide pins of the other brackets into the guide holes.

7. Screw the load carrier in place.
8. Check that the hook is properly secured in the roof bracket.
9. Tighten the knobs alternately until the carrier feels secure.
10. Replace the cover.
11. **Regularly check that the knobs are securely tightened.**

If you use load carriers

- To avoid damaging your car and to achieve the best level of safety when driving, we recommend that you only use load carriers that Volvo has specially designed for your car.
- **Check periodically that the load carriers and load are properly secured.** Lash the load securely with suitable straps.
- You can carry a **maximum of 100 kg** on the roof (including load carriers).
- Distribute the load evenly over the load carriers. Do not load lopsidedly. Place the heaviest items at the bottom.
- Remember that the car's centre of gravity and driving characteristics change if you have a load on the roof.
- Keep in mind that the car's wind resistance and fuel consumption increase in proportion to the size of the load.
- Drive gently. Avoid quick accelerations, heavy braking and taking curves hard.

The load and its position affect driving characteristics

At kerb weight your car has a tendency to understeer. This means that you will have to turn more and more sharply in the same bend if you accelerate. This also means that the car is stable and the chance of a rear wheel skid low. Bear in mind that these characteristics can change depending on how the car is loaded. As the load in the rear of the car increases, the car understeers less.

NOTE! The permitted total load and axle pressures must not be exceeded.

Floor carpets

Volvo supplies floor carpets specially manufactured for your car. These must be properly stuck down and secured with mat clips so as not to obstruct the pedals for the driver or cause inconvenience in other positions.

Manual gearbox

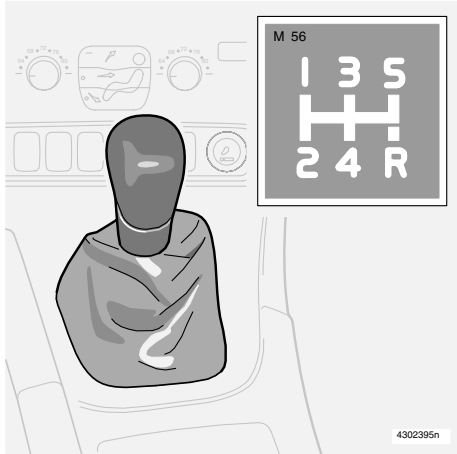

Gear position

Gear position, manual gearbox

Depress the clutch pedal fully with every gear change. Remove your foot from the clutch pedal between changes! Be sure to follow this shifting pattern.

Use the 5th gear as often as possible for speeds over 70 km/h (43 mph) in order to obtain the best fuel economy.

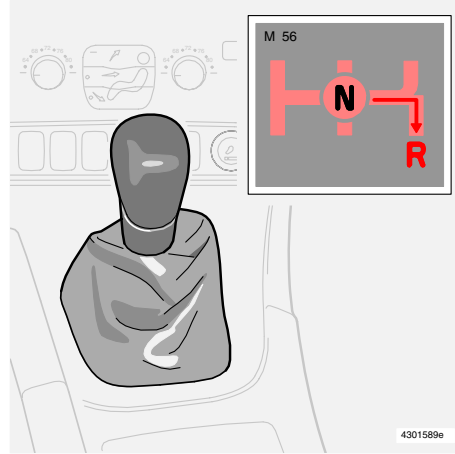

Reverse gear detent

Reverse gear detent

Engage the reverse gear when the car is stationary!

To put the car in reverse, the lever must first be moved to neutral position (between 3rd and 4th gear). Reverse gear cannot be selected directly from 5th gear because of the reverse gear detent.

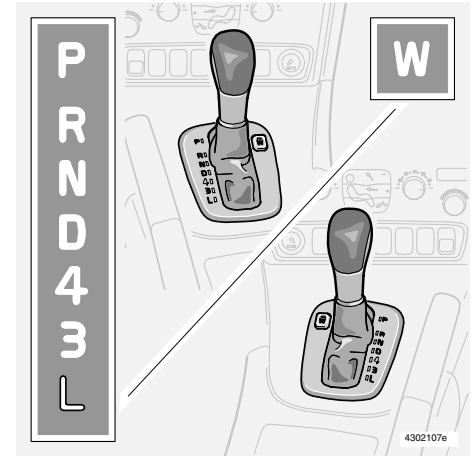

Gear selector positions

P – Parking

Select this position when you wish to start the engine or park the car.

The car should be stationary when you select P!

In the P position the gearbox is mechanically locked. Always apply the parking brake when parking!

R – Reversing position

The car should be stationary when you select R!

N – Neutral position

N is the neutral position. The engine can be started, but no gear is selected. Apply the parking brake when the car is stationary with the **gear lever in N**.

D – Driving position

D is the normal driving position. The car automatically shifts between the different gearbox gears based on the level of acceleration and speed. The car should be stationary when selecting D from position R.

4 – Low gear

Shifting up and down between the 1st, 2nd, 3rd, and 4th occurs automatically.

The 5th gear will not be engaged.

Position 4 can be used:

- for mountain driving
- when driving with a trailer
- to increase engine braking

3 – Low gear

Shifting up and down between 1st, 2nd and 3rd occurs automatically.

The 4th gear will not be engaged.

Position 3 can be used:

- for mountain driving
- when driving with a trailer
- to increase engine braking

L – Low gear position

Select L if you wish to drive in 1st or 2nd. Position L gives the best engine braking for mountain driving, etc.

Downshift inhibitor

There is a built-in inhibitor in the gearbox that prevents engine over-revving, when selecting one of the low gear positions.

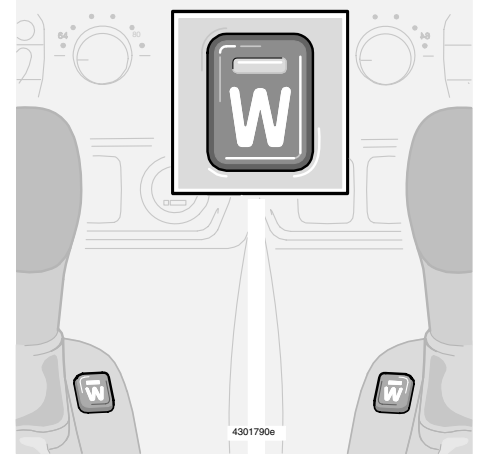

W - Winter

Use the button to switch the winter program **W** on and off.

The winter program makes it easier to drive at low speed in slippery road conditions. When the program is engaged, the driving wheels receive less power than normal and all upshifting occurs at a lower engine rpm.

The symbol **W** is displayed in the combined instrument panel.

NOTE! The **W** program cannot be selected if you have selected the manual positions.

Program **W** can only be selected in position **D**.

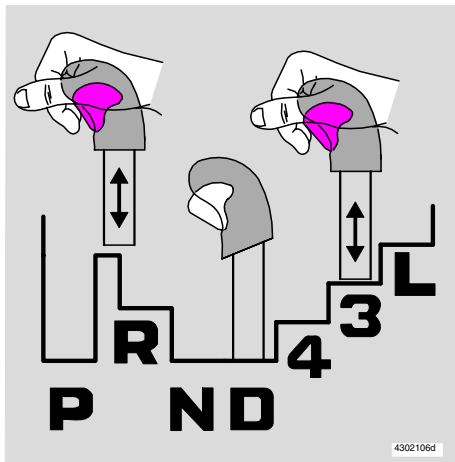

Gear selector inhibitor

You can always move the gear selector freely forward or backward between **N** and **D**. Other positions are locked with a latch that you can control with the inhibitor button on the gear selector.

Press the inhibitor button to move the gear selector forward or backward between **R** and **N**, and between **D**, **4**, **3** and **L**.

”Kick-down”

When you press the accelerator all the way down - beyond the position normally regarded as full acceleration - a lower gear is automatically engaged. This is called ”kick-down” down-shifting. When you reach the maximum speed for the gear or release the accelerator pedal from the ”kick-down” position, there is an automatic upshift. Use ”kick-down” when you want maximum acceleration, such as when overtaking. The gearbox is equipped with a downshift inhibitor on all gears.

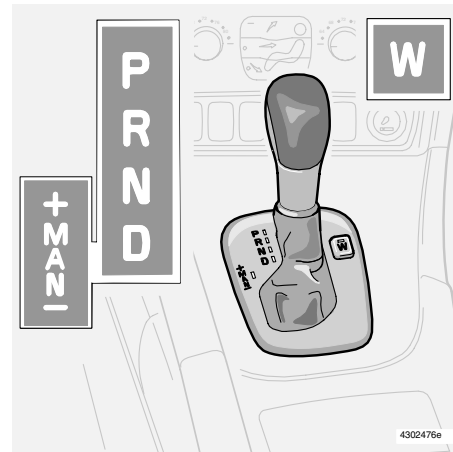

P – Parking

Select this position when you wish to start the engine or park the car.

The car should be stationary when you select P!

In the position **P** the gearbox is mechanically locked. Always apply the parking brake when parking!

Geartronic (option)

R – Reversing position

The car should be stationary when you select **R**!

N – Neutral position

N is the neutral position. The engine can be started, but no gear is selected. Apply the parking brake when the car is stationary with the gear lever in N.

D – Driving position

D is the normal driving position. The car automatically shifts between the different gearbox gears based on the level of acceleration and speed. The car should be stationary when selecting **D** from position **R**.

Gear selector manual position

If you wish to move from the automatic position **D** to the manual position, press the selector to the left. If you wish to move from **MAN** to position **D**, press the selector to the right and then up to **D**; 3rd, 4th and 5th have the Lock-up function (locked gears), which gives better braking and lower fuel consumption.

While moving:

The manual gear positions can be selected at any time in the journey. The selected gear is locked until another gear is selected. The gearbox downshifts only if you slow down to a very slow speed.

Holding the gear selector in minus (-) downshifts the car one gear position while simultaneously engine braking. Holding the gear selector in (+) shifts the car up one gear position.

3rd is the highest gear you can use when starting.

The Kick-down function is not available while you are in manual shifting mode. You must return to automatic position **D**.

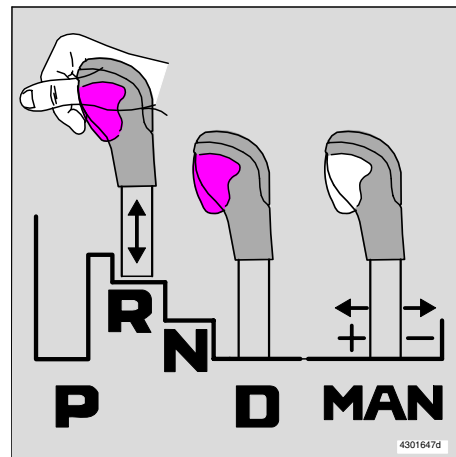

Gear selector inhibitor - Geartronic

You can always move the gear selector freely forward or backward between **D**, **N**, and **manual shifting mode**. Other positions are locked with a latch that you can control with the inhibitor button on the gear selector. Pressing the inhibitor button allows the gear selector to be moved forward or backward between the positions **P**, **R**, **N** and **D**.

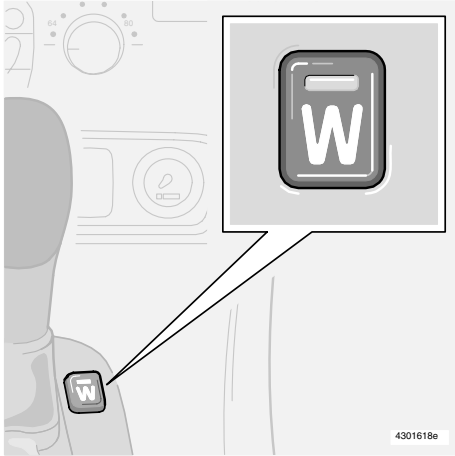

W - Winter

Use the button to switch the winter program **W** on and off.

The winter program makes it easier to drive at low speed in slippery road conditions. When the program is engaged, the driving wheels receive less power than normal and all upshifting occurs at a lower engine rpm. The symbol **W** is displayed in the combined instrument panel.

NOTE! The **W** program cannot be selected if you have selected the manual positions. Program **W** can only be selected in position **D**.

“Kick-down” - Automatic shifting

When you press the accelerator all the way down - beyond the position normally regarded as full acceleration - a lower gear is automatically engaged. This is called “kick-down” downshifting. When you reach the maximum speed for the gear or release the accelerator pedal from the “kick-down” position, there is an automatic upshift. Use “kick-down” when you want maximum acceleration, such as when overtaking.

The gearbox is equipped with a downshift inhibitor on all gears.

AWD – All Wheel Drive (option)

The all-wheel drive system in your Volvo, which is continuously engaged, conforms to advanced technical requirements. When used correctly, the all-wheel drive system provides the driver with better control on all types of road surfaces when compared with conventional rear-wheel drive.

All-wheel drive implies that the vehicle uses all four wheels simultaneously. Power is automatically distributed between the front and rear wheel pairs. An electronically-controlled clutch system distributes power to the wheel pair providing the best handling according to the prevailing road conditions, which in turn provides the best possible traction and prevents wheel spin. Under normal driving conditions, the majority of power is transmitted to the front wheels.

The improved traction increases driving safety in rain, snow and icy conditions.

Tyre dimensions and pressure

Volvo recommends driving with tyres which have the same make, size, specifications, load designation, and speed rating. Pressure is specified in the table on the inside of the fuel filler flap. See page 99.

Snow chains

Snow chains may only be fitted to the front wheel pair on all-wheel drive cars.

Use chains designed for AWD models only.

Important!

Only Volvo-approved snow chains are permitted. Use of other snow chains could damage your car.

Never drive faster than 50 km/h when snow chains are fitted!

Never use "quick links" because the space between the disc brakes and the wheels is too small.

Active chassis FOUR-C (option)

FOUR-C (Continuously Controlled Chassis Concept) is an advanced, electronically-controlled active chassis system.

System functions are based on a number of sensors which continuously adjust vehicle movements and reactions

The button in the centre console (see the illustration on page 31) can be used at random in order to select between two different settings: Comfort and Sport. The driver can adjust the suspension characteristics while driving - when switching driving style or when the character of the road surface changes. Adjustments occur within a few milliseconds.

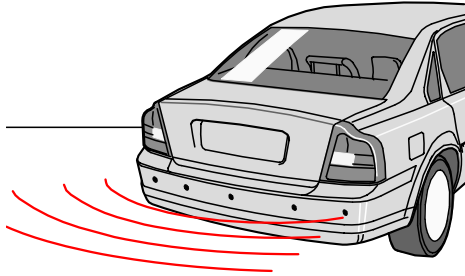

3603107d

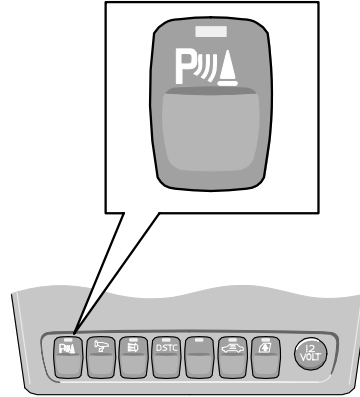

3602947r

Function

The Parking Assistance System can be used as an aid when parking the vehicle. An audible signal from the speaker system indicates the distance between the vehicle and the detected object; the audio system volume is lowered when the system is engaged. As the driver nears an object behind the car, the interval between signals becomes shorter. When the distance between the car and the object is approximately 30 cm, a continuous tone is audible. Distances are measured using ultrasonic technology via sensors mounted in the bumper; system range is approximately 1.5 m.

NOTE! Deactivate the system when driving with a trailer or bicycle holder mounted on the towbar or the sensors will react.

Activating/deactivating

The Parking Assistance System is activated once reverse gear is engaged if it has not been deactivated with the control located in the switch panel.

The LED in the control lights when the system is active.

Fault indication

If a system fault should be detected, the LED in the control will extinguish. A text message will be shown in the combined instrument panel display.

Cleaning the sensors

In order to ensure proper sensor function, they must be cleaned regularly with water and car washing liquid.

The Parking Assistance System is designed to aid the driver while parking but can never replace the responsibility normally assumed by the driver during parking. The sensors are designed to assist the driver and cannot detect objects inside their 'dead angles'. Be aware of children and animals in close proximity to the car.

Towing

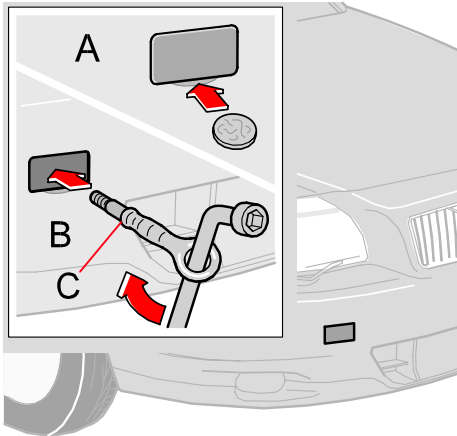

8600305e

Towing eye, front

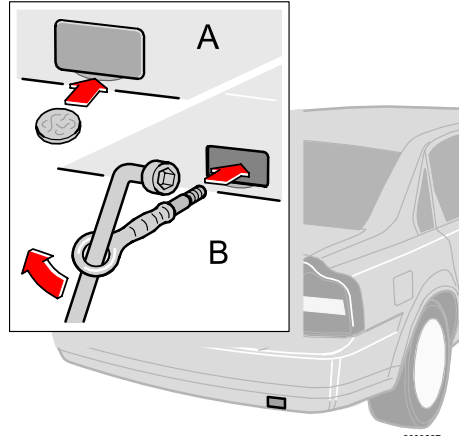

8600307e

Towing eye, rear

If you need to be towed

- Unlock the steering wheel lock so that the car can be steered.
- **Keep in mind the highest permitted legal towing speed.**
- Remember that the brake and power steering servos do not function when the engine is switched off! You must exert approximately five times more pressure on the brake pedal and steering is considerably harder than usual.
- Drive gently. Keep the towline taut to avoid unnecessary jerking.

For automatic gearboxes

- The gear selector should be in position N.
- Maximum permitted speed for cars with an automatic gearbox: 80 km/h (50 mph).
Maximum permitted distance: 80 km (50 miles).
- Cars equipped with an automatic gearbox must only be towed face forward.
- The engine cannot be towed to start (bump started). See “Jump starting” on the next page.

To tow start (bump start) the engine

If you bump start a car with manual gearbox, the catalytic converters will be damaged. Cars with automatic gearboxes cannot be bump started. Use a booster battery if the battery is discharged.

Towing eye

The towing eye is located in the tool kit in the cargo compartment. You must screw the towing eye into place before towing. The sockets and covers for the towing eye are located on the right-hand side of each bumper.

Remove the cover as follows:

- A. Loosen the bottom edge of the cover with a coin.
 - B. Screw the towing eye securely into place up to the flange (C). You can use a wheelbrace.
- After use, unscrew the towing eye and refit the cover.

Towing

NOTE! The towing eye may only be used for towing on the road, not for salvage after driving into a ditch or similar. Professional help should be called for salvage towing.

Jumpstarting

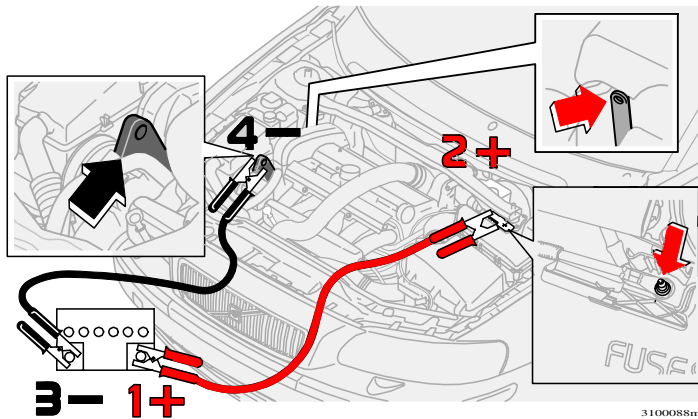

Jumpstarting with a booster battery is as follows:

If for some reason the battery in your car is discharged, you can "borrow" current from a spare battery or another car's battery to start the engine.

Always check that the clamps are secure so that there are no sparks during the start attempt.

To avoid the risk of explosion, we recommend you do exactly as follows.

- Turn the ignition key to position 0.
- Ensure that the booster battery has **12 volt current**.
- If the booster battery is in another car, stop the engine of that car and make sure the cars are not touching.
- Connect the red cable to the booster battery's positive terminal (1+ in the illustration) and the connection in your car's engine compartment (2+ in the illustration).

The clamp should be attached to the contact point located under a little black cover with a plus sign on it. The cover is connected to the cover of the fuse box.

WARNING!



Remember that batteries, especially the booster battery, contain oxyhydrogen which is highly explosive. A spark, which can be caused if you incorrectly install the jump leads, is enough to cause the battery to explode and both damage the car and injure you. The battery also contains sulphuric acid, which can cause serious corrosive damage. If the acid comes into contact with your eyes, skin or clothes, flush with large quantities of water. If acid splashes into your eyes contact a doctor immediately.

- Connect one end of the black cable to the booster battery's negative terminal (3- in the illustration).
- Connect the other end of the black cable to a grounding point on your car (4- in the illustration).
- Start the engine of the "booster car". Let the engine run a few minutes at a speed slightly higher than idle, 1500 rpm.
- Start the engine of the car with the discharged battery.
- **NOTE! Do not move the clamps during the start attempt (risk of spark buildup).**
- Remove the clamps in reverse order.

NOTE! If you need to help another car, connect the red cable as shown in the illustration above. Connect the black cable between two grounding points as also shown in the illustration. **Do not connect the black cable to the negative pole of another battery!**

Driving with trailer

Driving with trailer

- The towing bracket on the car must be of an approved type. Your Volvo dealer can advise you as to which towing bracket to use.
- Distribute the load in the trailer so that the weight on the towing bracket is approximately 50 kg for trailer weights under 1200 kg and approximately 75 kg for trailer weights over 1200 kg.
- Increase tyre pressure to correspond to the pressure for full load. See the tyre pressure table!
- Clean the towing bracket regularly and grease the towball* and all moving parts to prevent unnecessary wear.
- Do not drive with a heavy trailer when your car is brand new! Wait until it has gone at least 1000 km (620 miles).
- The brakes are loaded much more than usual on long and steep downhill slopes. Downshift to a lower gear and adjust your speed.
- If the car is driven with a heavy load in a hot climate, the engine and gearbox may overheat. The temperature gauge in the combined instrument panel goes into the red zone when the car overheats. Stop and let the engine idle a few minutes.
- If the car overheats, the air conditioning system can be temporarily switched off.
- The gearbox reacts with a built-in protection function if the car overheats. See the message in the display!
- The engine is loaded more heavily than usual when driving with a trailer.
- For reasons of safety, you should not drive faster than 80 km/h (50 mph), even if the laws of certain countries permit higher speeds.
- The highest permissible trailer weight for a trailer without brakes is 750 kg.
- If you park with a trailer, always move the gear selector to the P position (automatic transmission), or engage a gear (manual gearbox). If you park on steep hills always put chocks under the wheels.
- Avoid driving with trailer weights above 1200 kg on inclines greater than 12%. You should not drive with a trailer on inclines above 15%

* Does not apply to ball hitch with vibration damper.

Driving with trailer - automatic transmission

- When parking on a slope you should apply the parking brake before moving the gear selector to the P position. When starting on a slope you should first move the gear selector to the driving position and then release the parking brake.
- Select an appropriate low gear position on the gearbox when driving on steep slopes or if driving slowly. In doing so, you prevent the gearbox from changing up if you have an automatic transmission. The gearbox oil will be cooler.
- If you have a Geartronic transmission, do not use a higher manual gear than what the engine can "handle". It is not always economical to drive in high gears.

NOTE! Some models must be fitted with an oil cooler for the automatic transmission when driving with a trailer. You should therefore check with your closest Volvo dealer about just your car if a towbar has been fitted at a later date.

Driving with trailer

NOTE! The maximum permitted trailer weights stated are the ones that the Volvo Car Corporation allows. Remember that national vehicle regulations may further limit the trailer weight and speed. The towbars can be certified for higher towing weights than what the car may tow.

The highest permitted trailer weight for a trailer with brakes	Recommended ball pressure
0-1200 kg.....	50 kg
1201-1600 kg.....	75 kg
1601-1800 kg.....	75 kg

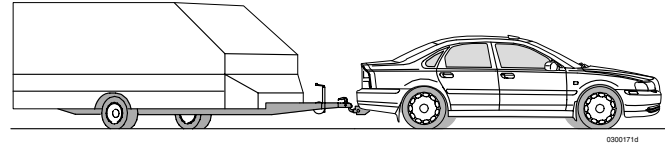

Level control

If your car is equipped with automatic level control, the rear end will always have the right height **while driving** irrespective of the load. The rear end drops when the car is at a standstill, which is quite normal.

WARNING!



If you do not follow the given recommendations, the trailer and car may be difficult to control during evasive manoeuvres and braking, which can be dangerous to you and others on the road.

Towing bracket

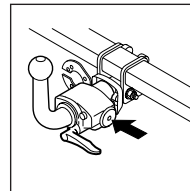
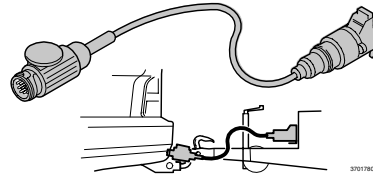
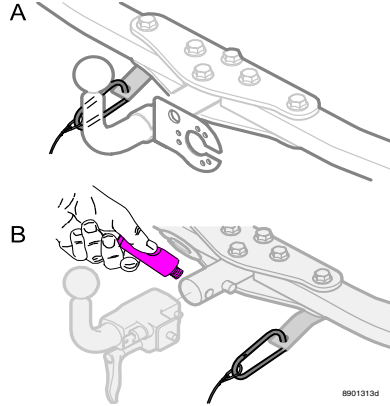

Fixed towbar(A)

Always remember to fasten the trailer's safety cable to the attachment. See the illustration.

Detachable towbar (B)

Always follow installation instructions carefully.

Always remember to fasten the trailer's safety cable to the attachment. See the illustration.

Always remember to clean and grease the connector pin regularly. Use the recommended grease 8624203.

NOTE! Your car may have a towing bracket with a 13-pin electrical connector, which you need to connect to a trailer with a 7-pin electrical connector. If this is the case, use only an original Volvo Genuine adapter cable. Ensure that the cable does not drag on the ground.

WARNING!



If your car is fitted with Volvo's detachable towbar: Make sure that the towbar is locked before you drive off.

- The red signal pin (see the arrow in the illustration to the left) should not be visible!
- Use the key to lock it.

See the description on page 95.

Towing bracket

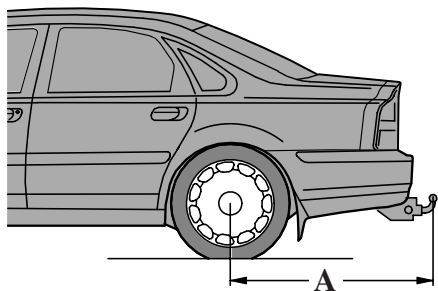

8902083d

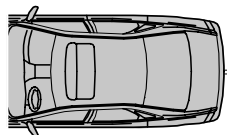

*Attachment points under
the car*

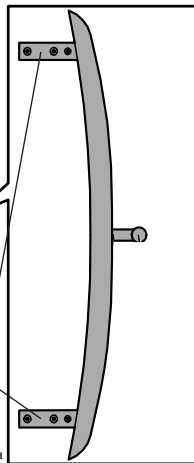

8902082d

Distance A above:

S80: 1152 mm

Max. ball pressure: 75 kg

Detachable towbar - mounting the ball section

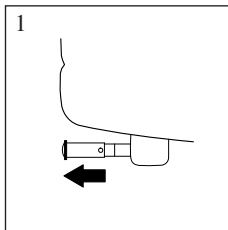

8902079M

Remove the connector pin cover.

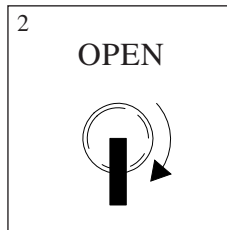

8902078M

Put in the key and turn it clockwise to the unlocked position.

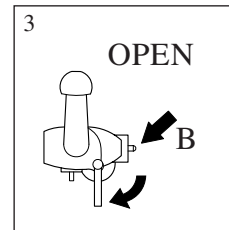

8902074M

Take the towball section and turn the handle clockwise until it stops.

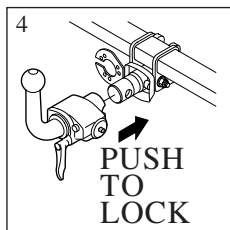

8902075M

Push the part with the ball in until it locks.

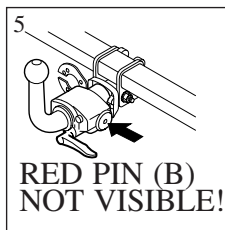

8902076M

Check that the signal pin (B) is pushed in.

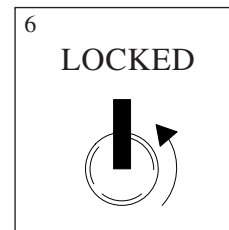

8902076M

Turn the key anticlockwise to the locked position and remove it from the lock.

Detachable towbar - removing the ball section

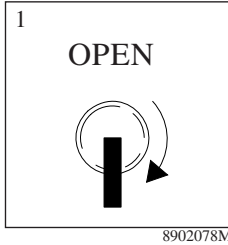

Put in the key and turn it clockwise to the unlocked position.

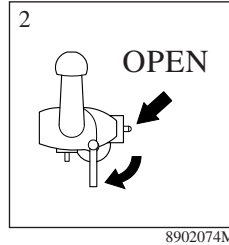

Turn the handle clockwise until it stops.

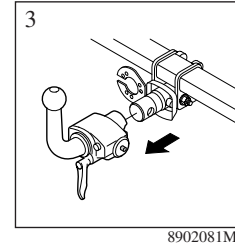

Pull the towball section from the connector pin.

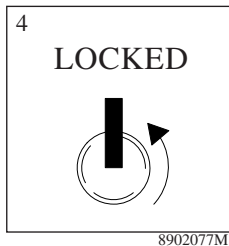

Turn the key anticlockwise to the locked position and remove it from the lock.

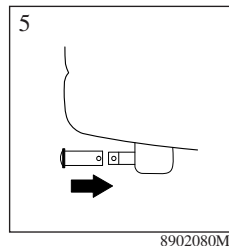

Refit the connector pin cover as in the illustration.

Wheels and tyres

General about wheels and tyres	98
Tyre pressures	99
Wear, Changing wheels, Spare wheel	100
Changing wheels	101

General wheels and tyres

All tyres have a dimension designation, such as 215/55R16 93W.

These tyre size designations, which are used by all tyre manufacturers, can be interpreted as follows:

- 215 section width (mm)
- 55 relationship between the section height and breadth (%)
- R means radial tyre
- 16 wheel rim diameter in inches (")
- 93 code digits for maximum permissible tyre load, in this case 650 kg
- W specifies that the tyre is manufactured for speeds up to 270 km/h (167 mph).

Your car is fully approved, which means that you may not deviate from those dimensions and performance ratings indicated in the vehicle registration. The only exception from these regulations concerns winter tyres and studded tyres, which may have different dimensions and a different speed rating than indicated in the registration. If you select tyres with different dimensions, do not drive at speeds faster than those permitted. The most common speed ratings are indicated in the following table:

- Q 160 km/h, used most often with studded tyres
- T 190 km/h
- H 210 km/h
- V 240 km/h
- W 270 km/h

Note: maximum permissible speeds indicated.

When you change tyres: be sure to use the same type (radial), dimension, designation, and brand on all four wheels. Otherwise, there is a risk that the handling characteristics of the car could change. Check with your dealer regarding dimensions which are available for your car. Keep in mind that the road surface can determine how fast you may drive, not the tyre speed rating.

New tyres

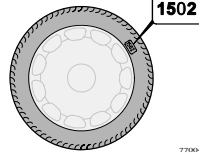

Bear in mind that tyres are perishable goods - after a few years they begin to harden while their friction properties deteriorate little by little. Try to use fresh tyres when changing.

This is especially important for winter tyres. The week and year of manufacture is indicated with 4 digits (e.g. 1502 indicates tyres manufactured week 15, 2002).

Winter tyres

We recommend the use of winter tyres, size 195/65 R15 except for cars with turbo engines. For these cars we recommend tyre size 205/55 R16.

Always use winter tyres on all four wheels!

NOTE: Always consult your Volvo dealer as to which wheel and tyre type is appropriate for your car.

Studded winter tyres

Studded winter tyres should be run in for 500-1000 kilometres (300-600 miles), softly and gently so that the studs sit in the tyre correctly. This extends the service life of both the tyres and the studs while making the drive a bit quieter. Ensure that the studded tyres have the same direction of rotation throughout their lifetime. If you wish to shift wheels, see to it that they remain on the same side as previously.

Please remember: The regulations for using studded tyres vary from country to country.

Snow chains

Snow chains may only be used on the front wheels.

Because of the limited space in the wheel arch we recommend that you do **not** use conventional snowchains. (Conventional snow chains can be used with 195/65R15 dimension tyres). Volvo-approved snow chains are available for all recommended standard rim/tyre combinations. Consult your Volvo dealer.

Tyre pressures

Snow chains and All Wheel Drive (AWD)

On vehicles equipped with All Wheel Drive (AWD), snow chains may only be fitted to the front wheels. Only use chains adapted for AWD models.

NOTE! You should never drive faster than 50 km/h (30 mph) with snow chains! Do not drive on bare roads unnecessarily because it wears away both your snow chains and tyres.

Driving characteristics and tyres

Tyres affect driving characteristics greatly. Tyre type, size and pressure are important to how the car performs. When you change tyres, be sure to use the same type, size and brand on all four wheels. Follow the recommendations regarding tyre pressure.

The tyre pressure is important!

Check the tyre pressure regularly. The correct pressure is listed in the adjacent table and on the decal on the inside of the fuel filler flap.

If you drive with tyres at the wrong pressure, the car's handling will be markedly impaired and tyre wear will increase.

Note that the values in the table refer to cold tyres (outside temperature). Tyres get warm and pressure increases after just a few kilometres driving. This is normal, so do not let out air if you check the pressure when the tyres are warm. However, you should increase pressure if it is too low.

Remember that tyre pressure can vary depending on exterior temperature. Therefore check the tyres outdoors when the tyres are cold.

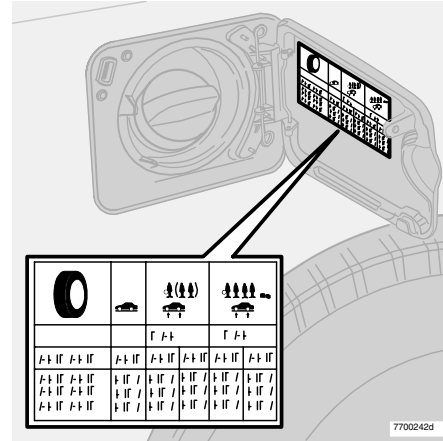

Tyre pressure table

The tyre pressure decal on the inside of the fuel tank filler flap indicates the tyre pressure your car should have.



WARNING!

The only Volvo approved "special wheel rims" are those tested by Volvo and are **Volvo Genuine parts**.

Wheels and tyres

Tyres with tread wear indicators

Tread wear indicators are narrow, raised areas across the tread that have approximately 1.6 mm less tread depth than the remainder of the tyre (the letters TWI are on the side of the tyre). When this bar is visible, only 1.6 mm of tread remains and the tyre should be replaced **immediately**. Bear in mind that road grip and the tyre's ability to push water out of the way is already affected markedly when there is 3-4 mm of remaining tread.

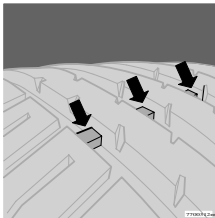

Changing the tyres - summer/winter

When you change between summer and winter tyres; mark on the tyre which side they were fitted: For example, L = left, R = right.

NOTE! Tyres should have the same direction of rotation throughout their life. Tyres with tread designs that are made to roll only in one direction, have the direction of rotation marked with an arrow on the tyre. If the tyres are fitted incorrectly this will impair the car's braking characteristics and the ability to disperse rain, snow and slush.

IMPORTANT!

Tyres with the greatest tread depth should always - irrespective of rear or front wheel drive - be fitted at the rear.

Contact your closest Volvo dealer to check if you are unsure.

Storage

Wheels should be stored horizontally or suspended, not vertically.

Spare wheel “Temporary Spare” (certain markets)

The “Temporary Spare” should only be used for the short time it takes to repair or replace the normal tyre.

By law it is only legal to temporarily use the spare wheel/tyre in connection with tyre damage. A wheel/tyre of this type should therefore be replaced by a normal wheel/tyre.

Bear in mind that this tyre combined with the other normal tyres may cause different driving characteristics.

The maximum speed with a “Temporary Spare” is therefore 80 km/h (50 mph).

NOTE! Only use the car's original spare wheel! Tyres of other dimensions may damage your car. Only **one** spare wheel may be used at a time.

Changing wheels

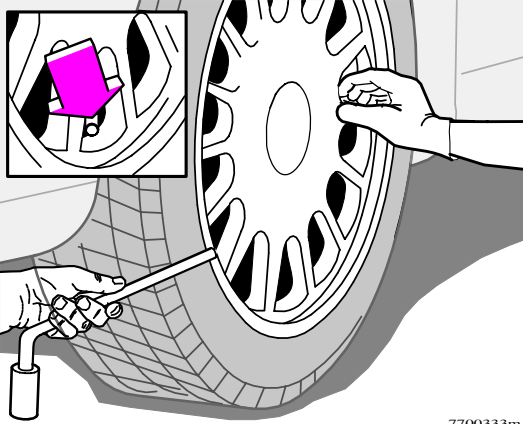

7700333m

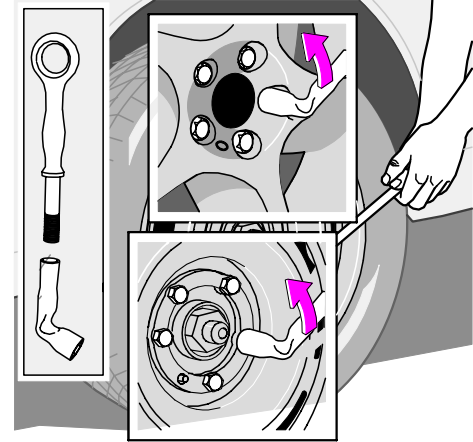

7700318n

Remove wheel studs

The spare wheel is stored under the carpet in the cargo compartment.

Remember to set out the warning triangle.

- Apply the parking brake and put into first gear on cars with manual transmission - position P on cars with automatic transmission. Put chocks in front and behind of the wheels that are to remain on the ground.
- Cars with **steel wheel rims** have removable wheel covers. Prise off the wheel cover with a thick screwdriver or the like. If tools are not available, the wheel cover can be prised off by hand. Use protective gloves. When you reinstall the wheel covers: ensure that the wheel cover valve hole is opposite the wheels air valve.
- Cars with aluminum rims with a cover: remove the cover using the socket wrench.
- Loosen the wheel nuts 1/2-1 with the socket wrench. The nuts are loosened by turning anticlockwise. There are two jacking points on each side of the car. The jacking points are marked on the door sill trims.

Changing wheels

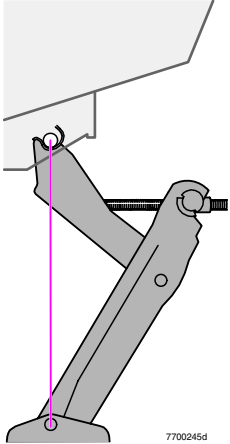

7700245d



7700244d

The jack should be located so

- Hold the jack against the pin in the jacking point as illustrated and wind down the jack foot so that it is pressed **flat against the ground**.
- **Check again that the jack is mounted correctly according to illustration and that the foot is positioned vertically under mounting.**
- Lift the car so that the wheel is free.
- Remove the wheel studs and lift off the wheel.

WARNING!



- **Never crawl under the car when it is raised on a jack!**
- The car and the jack should be on a solid **horizontal** surface.
- The car original jack should be used for wheel changing. All other work on the car should be carried out using workshop jacks and axle stands under the part of the car which is raised.
- Apply the parking brake, put into 1st gear or back up (reverse) on manual transmission and position P on the automatic transmission.
- Put chocks in front of and behind the wheels to remain on the ground.
- Use large wooden blocks or large stones.
- The jack screw should be kept well lubricated.

Fitting

- Clean the contact surfaces on the wheel and hub.
- Mount the wheel and tighten the wheel bolts.
- Lower the car so that the wheels cannot rotate. Tighten the wheel studs crosswise and in torque steps. Tightening torques: 140 Nm (14.0 kpm). It is important that they are tightened to the correct torque. Tightening should be checked with a torque wrench.
- Fit the hub cap.
- Screw the jack together before returning it to the cargo compartment.
- Ensure that the jack and tool kit are properly secured and do not cause any rattling.

Fuses, bulb replacement

Fuses	104
Replacing bulbs	108

Fuses

All electrical functions and components are protected with a number of fuses to protect your car's electrical system from damage by short-circuits or overloads.

Fuses are located in three different locations in the car:

- A - **Integrated relay/fusebox in engine compartment.**
- B - **Fusebox in passenger compartment.**
- C - **Integrated relay/fusebox in cargo compartment.**

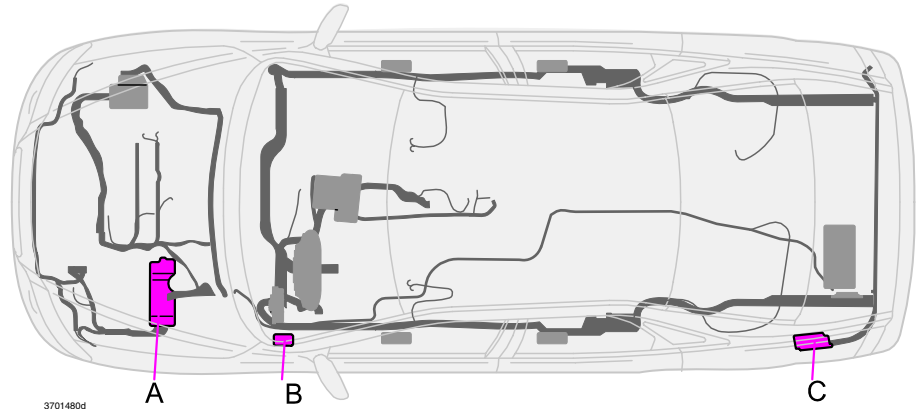

If an electrical component or function does not operate it may be because the component fuse was temporarily overloaded and burned out. Look in the fuse diagram to locate the affected fuse. Pull out the fuse and look at it from the side to see if the curved wire is burned out. Replace with a new fuse of the **same colour and ampere designation**.

The fuse box in the engine bay contains a number of spare fuses. There are also pliers to assist you in pulling out and replacing the fuses.

If the same fuse burns out repeatedly, there is a fault in the component, and you should visit your Volvo workshop to have it checked. Never change the main fuses in the engine or cargo compartments yourself.

Fuses in the engine compartment

In the fuse box in the engine compartment there are 8 positions for main fuses and 21 positions for regular fuses. Never change the main fuses yourself, have this done by an authorised workshop. If necessary, you can change the regular fuses yourself. Be sure to replace a blown fuse with a new one of the same colour and amperage.

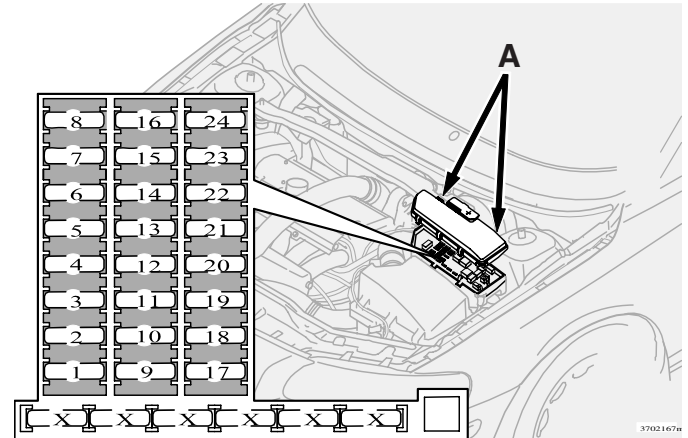
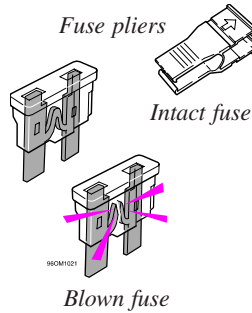

Fuses in the engine compartment

No	Ampere rating
1. Parking heater (option)	25
2. Auxiliary lamp (option)	20
3.	
4. Lambda sonds, engine control module (diesel), high pressure valve (diesel)	20
5. Crankcase ventilation heater, solenoid valves, Fuel distributor (Bi-Fuel)	10
6. Mass air flow sensor, engine control module, injectors	15
Mass air flow sensor (diesel)	5
7. Throttle module	10
8. AC compressor, accelerator position sensor, fan electronic box	10
9. Horn	15
10.	
11. AC compressor, ignition coils, solenoid valves (diesel)	20
12. Brake light contact	5

A. Press in the catches on the rear of the box and pull the cover up.

13. Windscreen wiper	25
14. ABS/STC/DSTC	30
15. Gas tank valve (Bi-Fuel)	15
16. Washer (windscreen), headlamp cleaner	15
17. Dipped beam (right)	10
18. Dipped beam (left)	10
19. ABS/STC/DSTC	30
20. Main beam (left)	15
21. Main beam (right)	15
22. Starter motor	40
23. Engine control module	5
24.	

Fuses in the passenger compartment

Fuses are located inside the access panel on the end face of the dashboard. There are also a number of spare fuses.

No	Ampere rating
1. Headlamp (dipped beam), Bi-Xenon (option)	15
2. Headlamp (main beam)	20
3. Power seat (driver)	30
4. Power seat (passenger)	30
5. Speed-dependent power steering, vacuum pump	15
6. Gas tank valve (Bi-Fuel)	5
7. Heated seat (front left)	15
8. Heated seat (front right)	15
9. ABS/STC/DSTC	5
10.	
11.	
12. Headlamp levelling, headlamp wiper	15
13. 12 V socket	15
14. Power seat (passenger), seatbelt catch (front), CEM	5
15. Audio, RTI (option)	5
16. Audio	20
17. Audio amplifier	30
18. Fog lamp (front)	15
19. RTI display (option)	10
20.	
21. Transmission unit 6 cyl, shiftlock, extended D2 feed	10
22. Direction indicator	20
23. Control unit lights, control unit climate control, diagnostic socket, control unit steering wheel levers	5
24. Extended D1 feed: Climate control unit, power seat (driver), combined instrument panel, parking heater (option)	10
25. Ignition switch (30 feed), central electronic module, relay starter motor, engine control module	10
26. Fan, climate control unit	30

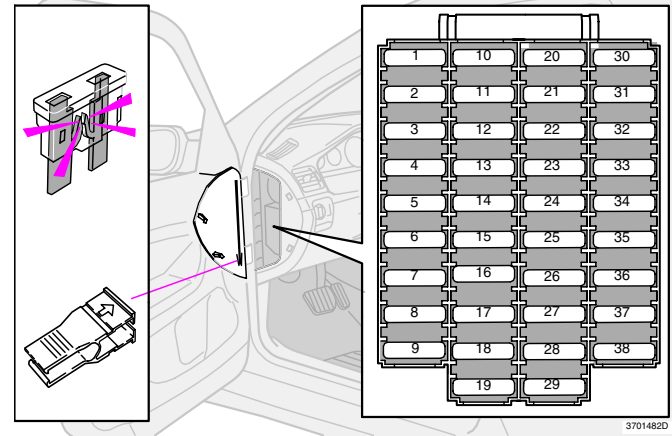

27. Active chassis FOUR-C	15
28. Electronic module (ceiling), interior lighting (ceiling)	10
29. Telephone (option)	10
30. Position/Parking lamp (left, front and rear)	7.5
31. Position/Parking lamp (right, front and rear), numberplate lighting	7.5
32. Central electronic module, vanity mirror lighting, power steering, general lighting, glovebox lighting	10
33. Fuel pump	15
34. Sunroof	15
35. Central locking, power window (front left)	25
36. Central locking, power window (front right)	25
37. Power windows (rear), child safety lock	30
38. Alarm siren	5

Fuses in the cargo compartment

The fuses are located behind the trim on the left-hand side. They are difficult to access. The main fuses are covered by a lid that is secured with screws. Main fuses should only be changed by authorized personnel.

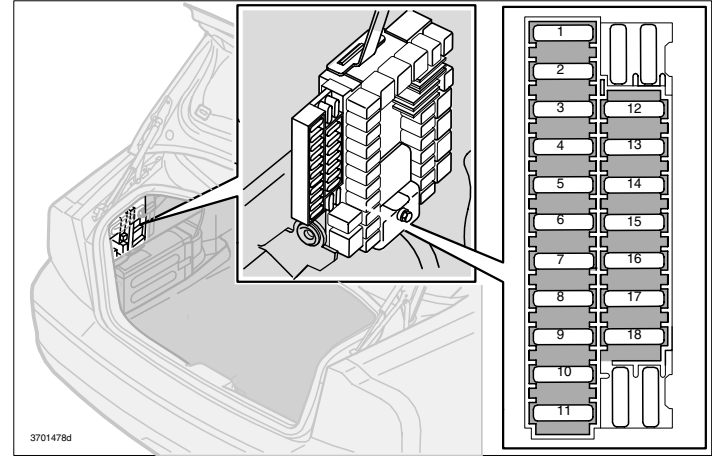
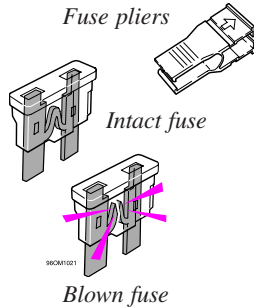

Fuses in the cargo compartment

No	Ampere rating
1. Rear electronic module (REM), lighting (cargo compartment)	10
2. Rear fog lamp	10
3. Brake light (cars with towbar only)	15
4. Reversing lamp	10
5. Heated rear window, relay 15I feed (rear)	5
6. Opening boot lid	10
7. Lowering head restraint	10
8. Locking rear doors, fuel filler flap	15
9. Towing bracket (30 feed)	15
10. CD changer (option), RTI (option)	10

11. Electronic module - AEM (option)	15
12.	--
13.	--
14.	--
15. Towing bracket (15I feed), Parking Assistance System	20
16. Socket, cargo compartment (option)	15
17. Heated fuel filter (diesel), Control module, AWD	7.5
18. Heated fuel filter (diesel)	15

Replacing bulbs

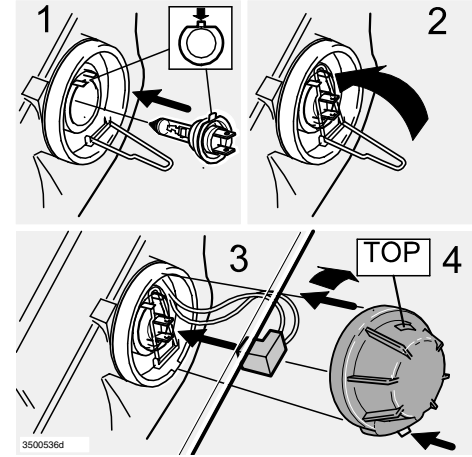
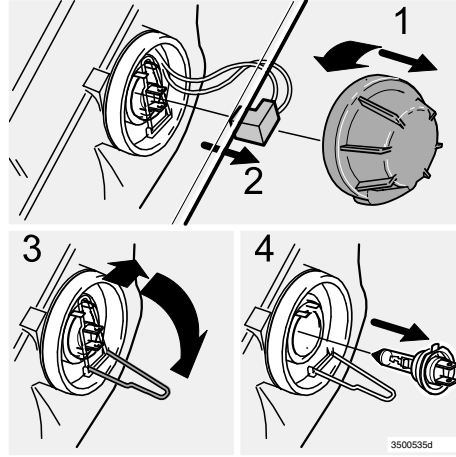
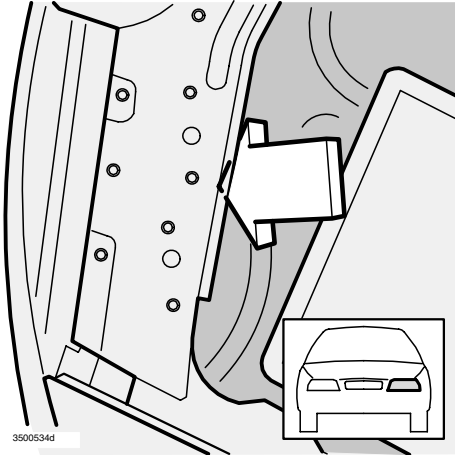

Replacing dipped and main beam bulbs (does not apply to Bi-Xenon)

Replace headlamp bulbs from the engine compartment.

NOTE! Never touch the bulb glass with your fingers. Grease and oil from your fingers evaporate in the heat and will leave a deposit on the reflector, destroying it.

- Switch off all lights and turn ignition key to position 0!
- Open the bonnet.
- Remove the cover by twisting anticlockwise (1).
- Pull off the connector (2).

- Disconnect the spring clamp. First push to the right so that the spring disconnects and then out and down (3).
- Pull the bulb out and replace with a new one (4).
- Replace the bulb (1). It can only be fitted in one position.
- Press the clamp spring upwards and a little to the left so that it secures in its catch (2).
- Press the connector back into place (3).
- Screw the cover back into place; "TOP" should be upwards (4)!

WARNING!



If your car is equipped with Bi-Xenon headlamps (option), the bulbs must be replaced by an authorised Volvo workshop due to the high voltage.

NOTE! Because Bi-Xenon lamps contain a little bit of mercury they must be handled correctly. Consult your Volvo dealer or Volvo workshop.

Replacing bulbs

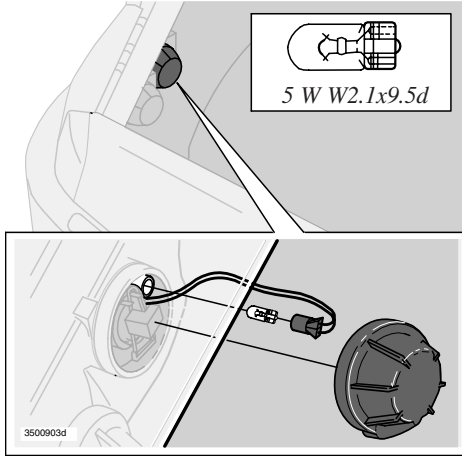

Replacing front position/parking lamp bulb*

- Switch off all lights and turn ignition key to position 0.
- Remove the main headlight cover by turning it anticlockwise.
- Pull out the bulb and its socket. Replace the bulb.
- Press the bulb and its socket back into place.
- Check that the new bulb lights.
- Screw the cover back into place; “TOP” should be up!

* On cars with Bi-Xenon headlamps, these bulbs sit in the direction indicator lamp housing. See next column.

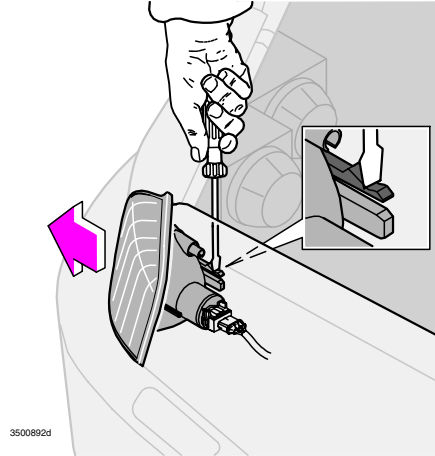

Replacing bulb in front corner

- Switch off all lights and turn ignition key to position 0.
- Using a screw driver, press the guide lug and pull out the entire lamp housing.
- Press down the spring clip and undo the connector from the lamp housing.
- Twist the bulb holder anticlockwise and remove it.
- Press the bulb inwards, turn it anticlockwise and remove it from the bulb holder.
- Replace with a new bulb and refit the bulb holder in the lamp housing.

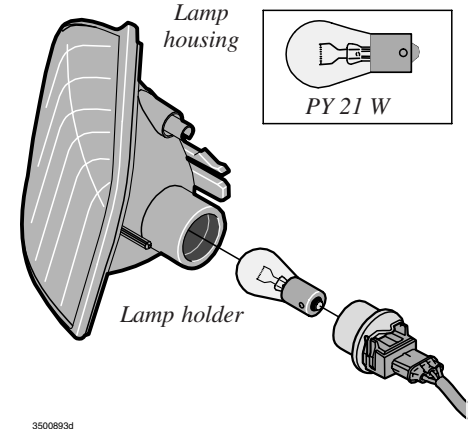

- Press the connector back onto the lamp holder.
- Switch on the ignition and check that the new bulb lights.
- Press the lamp housing home and check that it is seated securely.

For optimum reliability: Use Volvo Genuine bulbs!

Replacing bulbs

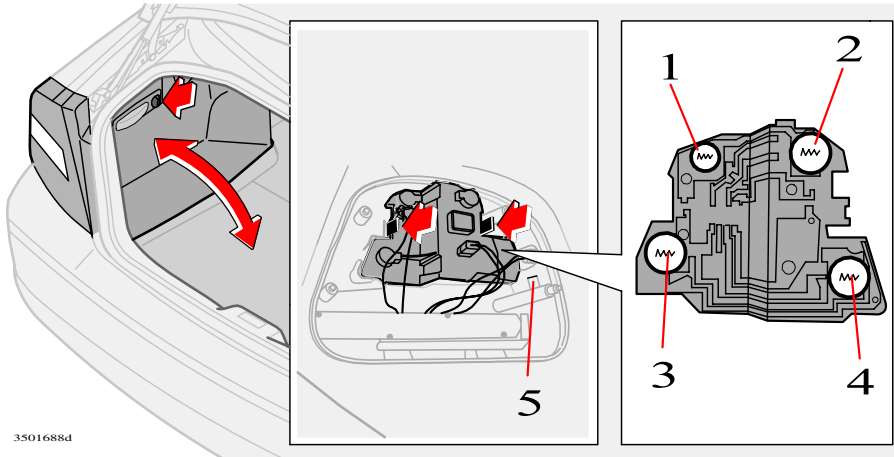

3501688d

Left-hand rear edge of car

1: Position lamp
5W BA15

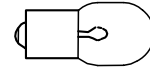

4: Reversing lamp
21W BA15

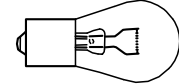

3: Position (direction indicator) lamp bulb
21W PY

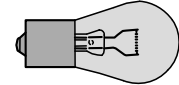

2: Position/Parking lamp/ Fog lamp bulb
21/4W BA15d

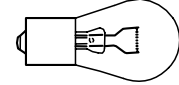

5: Position (side marker) light
5W5 W2,1x9.d

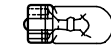

3501690d

Replacing bulbs in the rear lamp cluster

All bulbs in the rear lamp cluster can be replaced from inside the cargo compartment.

- Switch off all lights and turn ignition key to position 0.
- Unlock and fold down the side panel inwards to allow access to the bulbs. On the right-hand side, it is easier to access the bulbs if you first extend the load curtain as much as possible.

The bulbs are located in a removable lamp holder which is secured with two locking pins.

To replace bulbs in the lamp holder:

- Press the locking pins towards one another in order to remove the lamp holder from the lamp housing.
- Replace the bulb.
- Press back the lamp holder.
- Close and secure the side panel.

NOTE! LED brake light bulbs should be replaced at a Volvo workshop.

For optimum reliability: Use Volvo Genuine bulbs!

Replacing bulbs

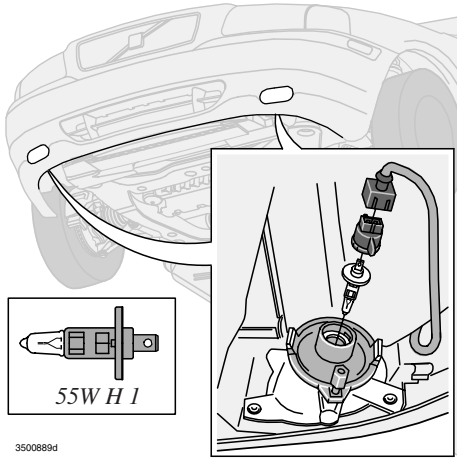

Replacing front fog lamp bulb

NOTE! Never touch the bulb glass with your fingers.

- Switch off the lights and turn the ignition key to position 0.
- Turn the bulb holder a little anticlockwise.
- Remove the bulb and replace with a new.
- Refit the bulb holder. (The profile on the bulb holder aligns with the profile on the base of the lamp).
- Replace the bulb holder by turning a little clockwise. The marking "TOP" on the headlamp cover should be upwards!

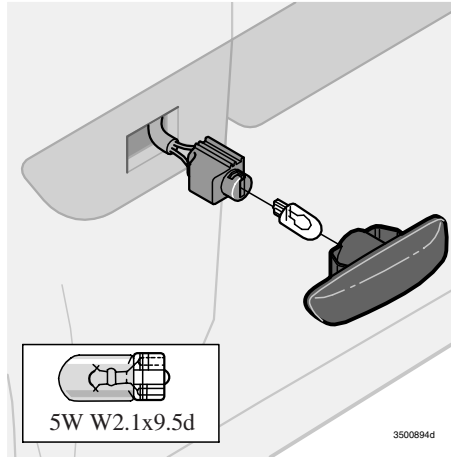

Replacing side direction indicator bulb

- Open the front door halfway.
- Insert your hand behind the front wing and press out the lamp. Allow the cables to remain in the bulb holder.
- Twist the bulb holder 1/4 turn anticlockwise and pull straight out.
- Pull the defective bulb straight out.
- Replace the bulb and press the lamp straight in.

**For optimum reliability:
Use Volvo Genuine bulbs!**

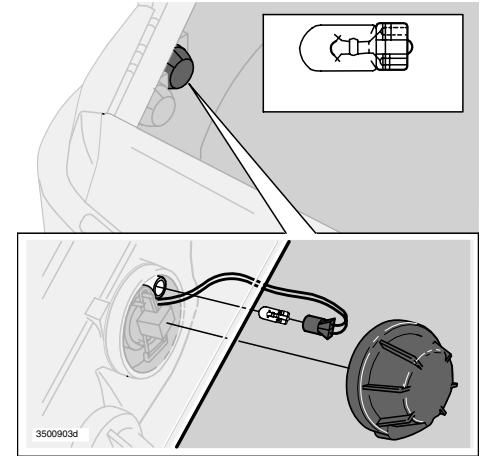

Replacing position/parking lamp bulb

- Switch off all lights and turn ignition key to position 0.
- Remove the main headlight cover by turning it anticlockwise.
- Pull out the bulb and its socket. Replace the bulb.
- Press the bulb and its socket back into place.
- Check that the new bulb lights.
- Screw the cover back into place; "TOP" should be up!

Replacing bulbs

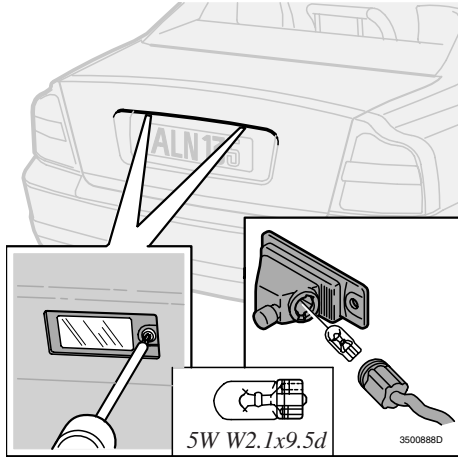

Replacing numberplate lighting bulb

- Switch off the lights and turn the ignition key to position 0!
- Remove the screw with a screwdriver.
- Loosen the whole lamp housing carefully and pull it out.
- Turn the connector anticlockwise and pull out the bulb.
- Replace bulb.
- Reinstall the connector and turn it clockwise.
- Reinstall and screw the whole lamp housing into place.

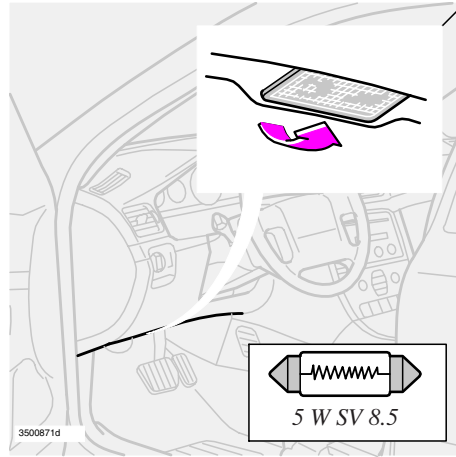

Replacing courtesy lighting bulb - front door

The courtesy lighting is under the dashboard on the driver's and passenger sides. Carry out the following to replace:

- Insert a screwdriver and twist lightly so that the lamp housing loosens.
- Remove the faulty bulb and install a new bulb.
- Check that lamp lights and reinstall the lamp housing.

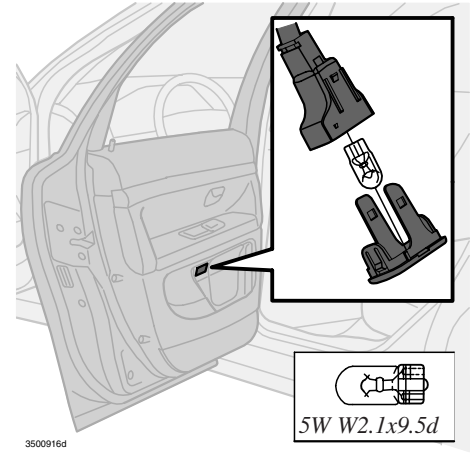

Replacing courtesy lighting bulb - rear door

- Insert a screwdriver and twist lightly so that the lamp housing loosens.
- Undo the cable from the lamp housing and then remove the glass from the lamp housing by pressing the two side clips outward.
- Pull out the old bulb and fit a new one.
- Refit in the reverse order.

**For optimum reliability:
Use Volvo Genuine bulbs!**

Replacing bulbs

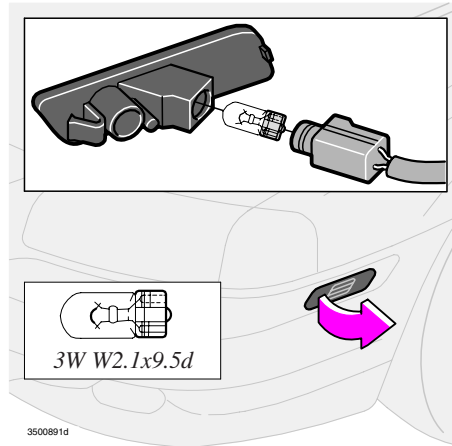

Replacing side marker bulb

- Press the entire lamp insert backwards and remove.
- Try if possible to remove the lamp insert with your fingers. Otherwise, use a plastic or wooden tool so as not to damage the paintwork.
- Turn the lamp holder anticlockwise and remove.
- Install a new bulb.
- Insert the lamp holder and turn it clockwise.
- Refit the lamp insert by pressing it into place in the body.

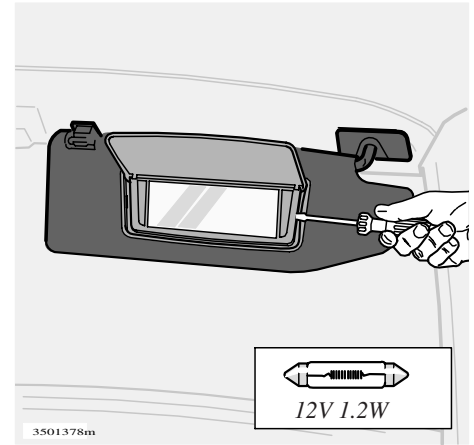

Insert screwdriver and turn carefully

Replacing the make-up-mirror bulb

- Insert a screwdriver and gently turn so that the glass loosens.
- Prise out the bulb and replace with a new one.
- Press the lamp glass back into place and make sure it is secured correctly.

**For optimum reliability:
Use Volvo Genuine bulbs!**

Replacing bulbs

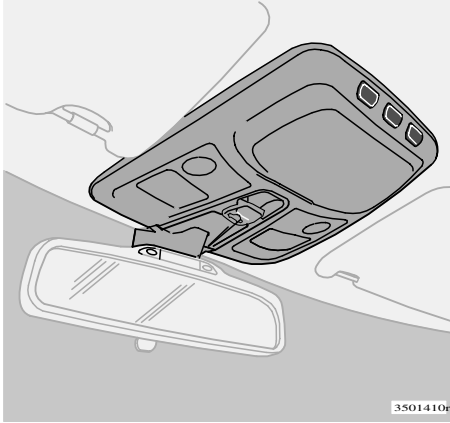

Replacing bulb in ceiling lighting with front reading lamps

These bulbs are of a special type. We recommend that you ask your Volvo workshop to replace this bulb.



Replacing bulb in rear reading lamp

These bulbs are of a special type. We recommend that you ask your Volvo workshop to replace this bulb.

Replacing high level brake lamp bulb

These bulbs are of a special type. We recommend that you ask your Volvo workshop to replace this bulb.

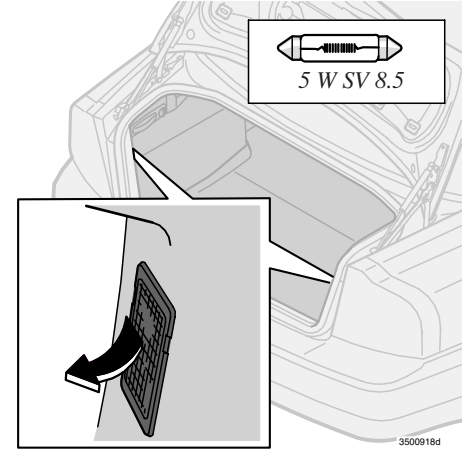

Replacing cargo compartment bulb

The lighting is to the left and right of the boot lid. Carry out the following to replace:

- Insert a screwdriver and twist lightly so that the lamp housing loosens.
- Remove the faulty bulb and install a new bulb.
- Check that the lamp lights and reinstall the lamp housing.

Car care and Service

Rustproofing	116
Checking and repairing paintwork damage	117
Washing	118
Service	120
Catalytic exhaust treatment	122
Environmental care	123
Bonnet, Engine Compartment	124
Diesel	126
Engine oil	127
Coolant	128
Brake fluid, Power steering, Windscreen washer fluid	129
Battery care	130
Replacing wiper blades	132

Rustproofing

Rustproofing - check and repair

Your Volvo received a very thorough and complete rustproofing at the factory. Areas that are extremely vulnerable, such as the underbody, have been sprayed with a thick, wear-resistant anti-corrosion compound on the outside. Members, cavities and enclosed sections are sprayed internally with a thin, penetrating rust inhibitor.

The car's rustproofing is maintained by doing the following:

- Keep the car clean! Wash chassis components*, the underbody, and the inside and edges of wheel arches with a pressure washer. When high pressure washing - hold the spray nozzle at least 30 cm away from painted surfaces!
- Check and repair the rustproofing regularly.

* Trailing arms, link arms, spring mountings and spring strut seats.

The car's rustproofing does not normally require treatment for approximately 8 years. After that time, it should be treated at three year intervals. If your car requires treatment, consult your Volvo workshop.

Visible rustproofing

Periodically check and touch up the "visible" rustproofing. Make good the rustproofing immediately so that moisture does not have a chance to penetrate - let your Volvo workshop help you.

If you want to repair the rustproofing yourself, make sure the area is clean and dry. Hose down, wash and dry the car thoroughly. Use a rustproofing agent in a spray can or one that is intended for brush application.

Two types of rustproofing agent are available:

- a) thin (colourless), for visible places
- b) thick, for areas prone to wear on the underbody and in the wheel arches

Possible repair areas with these agents:

- Visible welds and sheet metal joints - thin fluid
- Underbody and wheel arches - thick fluid
- Door hinges - thin fluid
- Bonnet hinges and catch - thin fluid

When you have finished treatment, excess rustproofing can be wiped off using a rag dampened with white spirit.

Parts of the engine and suspension strut mountings in the engine bay are treated at the works with a wax-based colourless rustproofing agent. This withstands normal detergents without dissolving and losing its rustproofing ability. On the other hand, if you wash the engine using aromatic solvents such as turpentine or white spirit (especially those which do not contain emulsifiers), the protective wax should be renewed after washing. Your Volvo dealer has such waxes in stock.

Repairing paintwork damage

Paint

Paint is an important part of the car's rustproofing and should therefore be checked regularly. Repair paintwork damage immediately so that it does not start to rust. The most common types of paintwork damage that you can repair yourself are:

- minor stone chips and scratches
- damage to wing edges and sills

When repairing paintwork, the car should be clean and dry with a temperature above + 15°C.

Colour code

Make sure you have the right colour. The colour code number is on the data plate in the engine compartment.

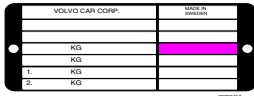

Colour code

Minor stone chips and scratches

Material:

- Primer in a can
- Paint in a can or a touch-up pen
- Brush
- Masking tape
- If the stone chip has not gone down to the bare metal and an unpainted colour coat remains, you can add paint immediately after removing dirt.

Do as follows if the stone chip went down to the bare metal:

- Fasten a piece of masking tape over the damaged surface. Then remove the tape, removing any paint residue (illustration 1).
- Stir the primer thoroughly and apply using a fine brush or matchstick (illustration 2).
- When the primer is dry, apply the surface coat with a brush.
- Ensure that the paint is well stirred and apply several thin coats allowing it to dry between coats.
- The procedure is the same for scratches, but masking tape can be used to protect undamaged paintwork (illustration 3).
- Wait a day or so and then finish the repair by polishing. Use a soft rag and apply lapping paste sparingly.

Remove any paint residue with tape

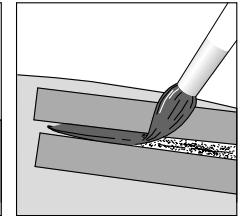
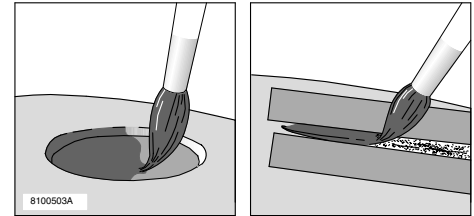
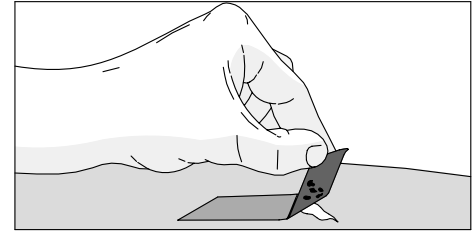

Mask if necessary

Washing

Wash the car frequently!

Wash the car as soon as it becomes dirty, especially in the winter when road salt and moisture can lead to corrosion.

Wash the car as follows:

- Thoroughly hose off the dirt on the car underbody (wheel arches, wing edges, etc.).
- Rinse the whole car until the dirt has softened.
- When using high pressure hose:
Ensure that the high pressure hose nozzle does not come nearer than 30 cm from the bodywork. Do not spray directly at the locks.
- Wash with a sponge using a lot of water with or without detergent.
- You can use lukewarm (maximum 35 °C) but not hot water.
- If the dirt is ingrained, you can wash the car with cold degreasing agent, but then be sure that there is a drain separator where you are washing the car. When using cold degreasing agent, ensure that the car is not in direct sunlight or that the paint is warm from sunlight or a warm engine. Sunlight and heat can cause permanent damage. Consult your Volvo workshop.
- Dry the car with a clean, soft chamois.
- Clean the wiper blades with a lukewarm soap solution.

Suitable detergent:

Car shampoo.

Keep in mind the following:

Always wash off **bird droppings** from the paintwork as fast as possible. Bird droppings contain chemicals that affect and discolour paintwork quickly. The discoloration cannot be polished off.

WARNING!



After washing: always test the braking so that damp and corrosion do not affect the brake pads and impair the brakes! Depress the brake pedal lightly now and again when driving longer distances in the rain or slushy snow to warm up and dry the brake discs and pads. You should also do this when starting in very damp or cold weather conditions.

WARNING!



Do not wash the engine when it is still warm. Fire risk!

Automatic car wash

An automatic car wash is a simple and fast way of washing the car. Remember that an automatic car wash can never replace a proper hand-wash.

The brushes of an automatic car wash do not reach all areas. During the first months of the car's life it is recommended that you only handwash the car.

Polishing and waxing

Polish and wax the car when you feel the paintwork is matte and when you wish to give the paintwork extra protection, such as before winter. The car does not usually need polishing until after one year. It can be waxed earlier.

Wash and dry the car thoroughly before you begin polishing and/or waxing. Clean of asphalt and tar stains with white spirit. More stubborn marks can be removed with fine rubbing paste designed for paintwork. Polish first with a polish and then wax with fluid or solid wax. Carefully follow the instructions on the package. Many preparations contain both polish and wax. Do not polish or wax surfaces warmer than 45 °C.

Cleaning the upholstery

Treating marks on fabric

A special cleaning agent available at your Volvo dealer is recommended when cleaning fabric upholstery. Other chemicals can impair the fire retardant qualities of the upholstery.

Treating marks on vinyl

Never scrape or rub a mark. **Never** use strong stain remover. Wash with a weak soap solution and lukewarm water.

Treating marks on leather

A special cleaning agent available at your Volvo dealer is recommended when cleaning leather upholstery. Use the Volvo leather care kit once or twice a year to preserve suppleness and comfort.

Never use strong detergent, petrol, alcohol, white spirit, etc. as such strong substances can damage fabric, vinyl and leather upholstery.

Cleaning seat belts

Use water and synthetic detergent.

Volvo Service

Before the car left the factory, it was thoroughly test driven. It was checked again in accordance with Volvo Car Corporation regulations before it was handed over to you.

Volvo service programme

In order for you to keep your Volvo at the highest level of traffic safety, driving safety and reliability you should follow the Volvo service programme which is specified in the Warranty and Service schedule. We advise you always to let a Volvo workshop carry out the servicing and repair work. Your Volvo workshop has the personnel, the special tools and the service literature which guarantees you the highest quality of service. Your Volvo workshop always uses Volvo Genuine parts. The Volvo Service schedule is developed for the normal motorist.

Important!

For the Volvo warranty to apply, check and follow the instructions in the Service and Warranty Manual.

Adverse driving conditions

Change engine oil and replace air and oil filters more often than recommended in the Service and Warranty Booklet when driving in adverse conditions.

Adverse driving conditions include:

- Prolonged driving in dusty/sandy conditions
- Prolonged driving with caravan or trailer
- Prolonged driving in mountainous areas
- Prolonged driving at high speeds
- Prolonged idling and/or driving at low speeds
- Driving in low temperatures - below 0°C - along shorter distances; less than 10 km.

WARNING!



The car ignition system has very high voltage!
The voltage in the ignition system is dangerous!
Do not touch spark plugs, ignition cables or the ignition coil when the engine is running or the ignition is switched on!

The ignition should be switched off when:

- Conducting engine tests.
- Replacing parts in the ignition system, such as spark plugs, ignition coil, distributor, ignition cables, etc.

Note the following before you begin working on your car:

Battery

- Ensure that the battery cables are correctly connected and tightened.
- Never disconnect the battery when the engine is running (e.g. when replacing the battery).
- Never use a fast charger to charge the battery. The battery cables should be disconnected when recharging.

Environmental care

The battery contains acid that is both corrosive and poisonous. It is important that the battery is handled in an environmentally friendly way. Let your Volvo dealer assist you.

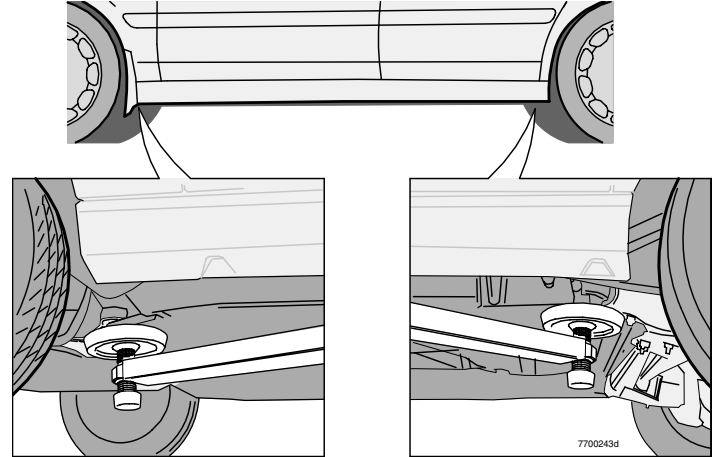

Lifting the car

If the car is lifted with a workshop jack, it should sit with the front edge on the engine support arm. Do not damage the splashguard under the engine. Ensure that the jack is positioned so that the car cannot slide off the jack. Always use axle stands or the like.

If you lift the car using a two pillar workshop lift, ensure that the front and rear lift arms are fixed under the lifting points on the door sill. See the illustration.

Catalytic exhaust treatment

Catalytic converter

The catalytic converter is an additional part of the exhaust system. Its purpose is to purify exhaust. The converter primarily consists of a housing with two monoliths that are designed so that the exhaust gases pass through a honeycomb of channels. The channel walls are lined with a thin layer of platinum, rhodium and palladium. These metals act as catalysts, i.e. they participate in and accelerate a chemical reaction without being used up themselves.

Lambda-sond™ (oxygen sensor, petrol engines only)

The lambda sensor is part of a management system intended to reduce emissions and improve fuel economy. An oxygen sensor monitors the oxygen content of the exhaust gases leaving the engine. These values are fed into an electronic system that continuously controls the injectors. The ratio of air to fuel is continuously adjusted. These adjustments create optimal conditions for efficient combustion, and together with the three-way catalytic converter reduce harmful emissions (hydrocarbons, carbon monoxide and nitrous oxides).

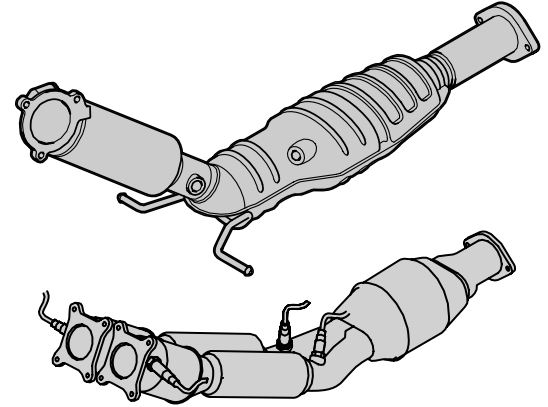
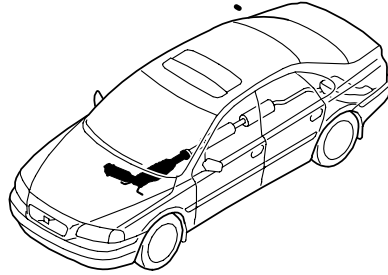

2501092a

NOTE!

Cars with petrol engines must only be run on **unleaded** petrol. Leaded petrol damages the catalytic converter.

Environmental care, Fuel consumption and emissions

Environmental care

There are many examples of environmental care within the Volvo field of activity. We use a chlorine-free refrigerant in our climate control systems that is harmless to the ozone layer and contributes very little to the greenhouse effect. Asbestos-free brakes, engines with catalytic converters and biogas operation are other examples of what Volvo Car Corporation is doing for the environment.

Our specific services are also of importance to the environment, such as using Volvo Genuine parts, maintaining ignition and fuel systems, and other measures that directly reduce exhaust emission.

We would also like to point out the care taken by our Volvo workshops in regards to handling environmentally dangerous substances.

Fuel consumption and carbon dioxide emissions

Engines	Gearbox	Fuel cons. litre/100 km	Carbon dioxide mission emission (CO ²) g/km
B5204T5	Manual	9.4	223
	Automatic	10.4	246
B5244S	Manual	9.0 - 9.1	214 - 217
	Automatic	9.7 - 9.8	232 - 235
B5244S2 (170 bhp)	Manual	8.9 - 9.0	212 - 215
	Automatic	9.6 - 9.7	229 - 232
B2524T2 (2.5T)	FWD Manual	9.3	222
	FWD Automatic	10.0	239
	AWD Automatic	10.5 - 10.7	252 - 256
B6294S2	Automatic	10.6 - 10.9	255 - 259
B6294T (T)	Automatic	11.1 - 11.3	268 - 272
D5244T (D5)	Manual	6.5	172
	Automatic	7.7 - 7.8	204 - 207
D5244T2 (2.4D)	Manual	6.5	171
	Automatic	7.7 - 7.8	204 - 207

Official fuel consumption figures are based on a standard driving cycle; EU directive 80/1268 comb.

Fuel consumption figures can be altered if the car is equipped with extra options which affect car weight. The manner in which the car is driven and other non-technical factors can affect fuel consumption

Bonnet, Engine compartment - left-hand drive

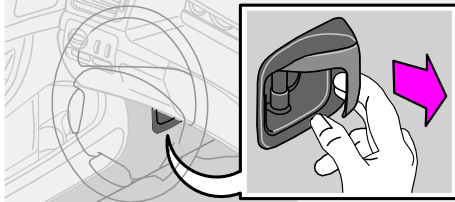

Pull the handle...

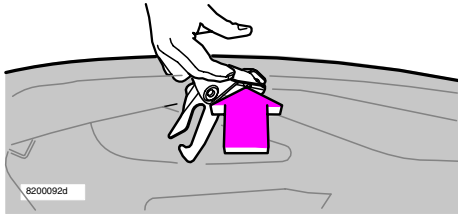

...press up and open

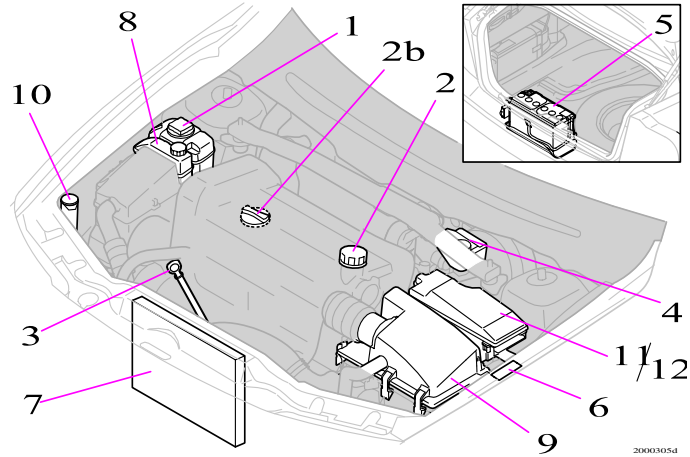

Opening the bonnet

Pull the handle on the far left under the dashboard. You hear when the lock releases. Insert the hand in the centre of the front edge of the bonnet and press up the safety catch handle. Open the bonnet.

Engine compartment

- | | | | |
|---|--------------------------------|----|--------------------------------|
| 1 | Expansion tank, cooling system | 7 | Radiator |
| 2 | Engine oil filler pipe | 8 | Power steering fluid reservoir |
| 3 | Engine oil dipstick | 9 | Air filter |
| 4 | Clutch/brake fluid reservoir | 10 | Washer fluid reservoir |
| 5 | Battery (in cargo compartment) | 11 | Main fuse box |
| 6 | Data plate | 12 | Integrated relay/fuse box |

WARNING!



Check that the bonnet lock properly when you close it!

WARNING!



Electric engine cooling fan:

Cooling fan may continue running and can start itself after the engine is switched off!

Bonnet, Engine compartment - right-hand drive

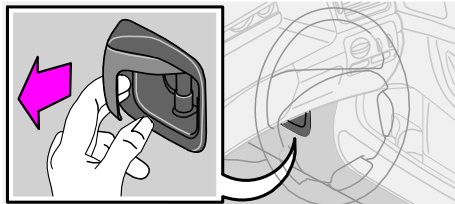

Pull the handle...

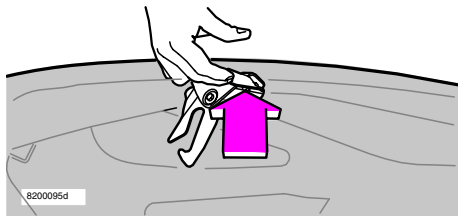

...press up and open

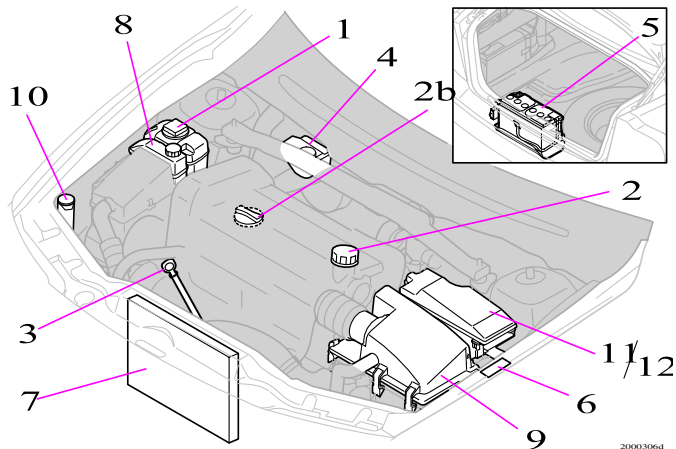

Opening the bonnet

Pull the handle on the far right under the dashboard. You hear when the lock releases. Insert the hand in the centre of the front edge of the bonnet and press up the safety catch handle. Open the bonnet.

Engine compartment

- | | | | |
|---|--------------------------------|----|--------------------------------|
| 1 | Expansion tank, cooling system | 7 | Radiator |
| 2 | Engine oil filler pipe | 8 | Power steering fluid reservoir |
| 3 | Engine oil dipstick | 9 | Air filter |
| 4 | Clutch/brake fluid reservoir | 10 | Washer fluid reservoir |
| 5 | Battery (in cargo compartment) | 11 | Main fuse box |
| 6 | Data plate | 12 | Integrated relay/fuse box |

WARNING!



Check that the bonnet locks properly when you close it!

WARNING!



Electric engine cooling fan:

Cooling fan may continue running and can start itself after the engine is switched off!

Fuel system

Diesel engines are very sensitive to contamination. Only use diesel fuel from well known oil companies. Never use diesel of doubtful quality. The major oil companies can also offer a special diesel fuel for winter use. This fuel is much thinner when the temperature is low, which reduces the risk of waxing in the fuel system. The risk of condensation in the fuel tank is less if it is kept rather full.

During filling you should check that the area around the filler pipe is clean. If you do the refuelling from a tank of your own, you should filter the fuel.

Avoid spilling onto the paintwork. Wash off any spills with detergent and water.

Empty tank

No special procedures are required if the tank runs dry. The fuel system is bled automatically.

RME (Rape Methyl Ester)

- 5% RME may be added to diesel.

Draining condensation water from fuel filter

The fuel filter removes condensation, which could otherwise affect engine function, from the fuel. The fuel filter should be drained as specified in the Service and Warranty Book, and when you suspect that the car has been filled with contaminated fuel.

Engine oil

Oil grade:

Petrol engines: ACEA A1 ACEA A3 grade oil can also be used.
Note that the same oil can comply with both ACEA A1 and ACEA B1, regardless of whether it is a mineral, semi-synthetic or fully synthetic oil.

Diesel engines: ACEA B4

Note that the same oil can comply with ACEA A3, ACEA B3 and ACEA B4, regardless of whether it is a mineral, semi-synthetic or fully synthetic oil.

Do not use extra additives. These can damage the engine.

Castrols® fully synthetic engine oil is recommended for turbocharged petrol and diesel engines.

Volvo recommends Castrol® oil products.

Changing the oil and oil filter

Your Service and Warranty Manuals contain instructions regarding suitable intervals for changing oil and oil filters.

Shorter intervals are recommended for driving in adverse conditions*.

*: see page 120

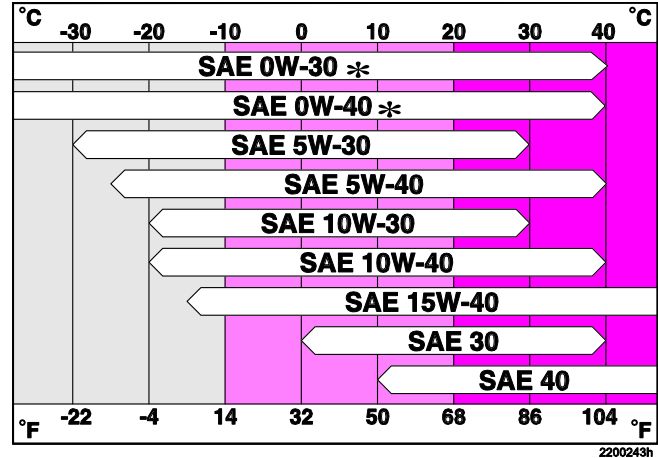

Viscosity (assumes constant air temperature)

For extreme driving conditions that produce abnormally high oil temperatures or oil consumption, such as driving in mountainous terrain with a great deal of engine braking or high-speed motorway driving, oil grade **ACEA A3 (petrol engines)** is recommended.

* Oils with viscosity 0W-30 and 0W-40 must fulfil the requirements of ACEA A3 (petrol engines).

Check engine oil regularly when refuelling

Volvo recommends that the oil level be checked every 2 500 km (1 550 miles). This is especially important during the period up to the first scheduled oil change. Park the car on a level surface and wait at least five minutes after turning off the engine so that the oil can run back to the oil sump.

The most accurate measurement is made on a cold engine before starting.

Wipe dipstick before check.

The oil level should fall within the markings on the dipstick.

The distance between MAX and MIN on the dipstick corresponds to approx. 1.5 litres for petrol engines and 2 litres for diesel engines.

If the level is at MIN: Fill with...

...cold engine 1.0 litres

...warm engine 0.5 litres

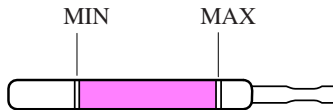

Approx. 1.5 litres for petrol engines

Approx. 2.0 litres for diesel engines

WARNING!



Do not spill oil on the hot exhaust pipe.
Fire risk!

Coolant

Never top up with ordinary water only! Use a mixture of half water, half **Volvo coolant** all year round.

NOTE! Certain engine components are manufactured of an aluminium alloy and it is therefore important that Volvo coolant is always used. It has especially good anti-corrosion properties! When the car is new it is filled with engine coolant to withstand approximately -35°C .

Check coolant regularly!

The level should lie between the MIN and MAX marks on the expansion tank. Top up the coolant if the level falls below the MIN mark.

If you need to top up the coolant when the engine is warm, unscrew the expansion tank cap slowly so that the overpressure dissipates.

NOTE! The engine must only be run with a well-filled cooling system. If the system is not well filled, high temperatures can occur, causing a risk of cracks in the cylinder head.

Let your Volvo dealer help you.

WARNING!



If you need to top up the coolant when the engine is warm, unscrew the expansion tank cap slowly so that the overpressure dissipates.

Brake fluid, Power steering, Windscreen washer fluid

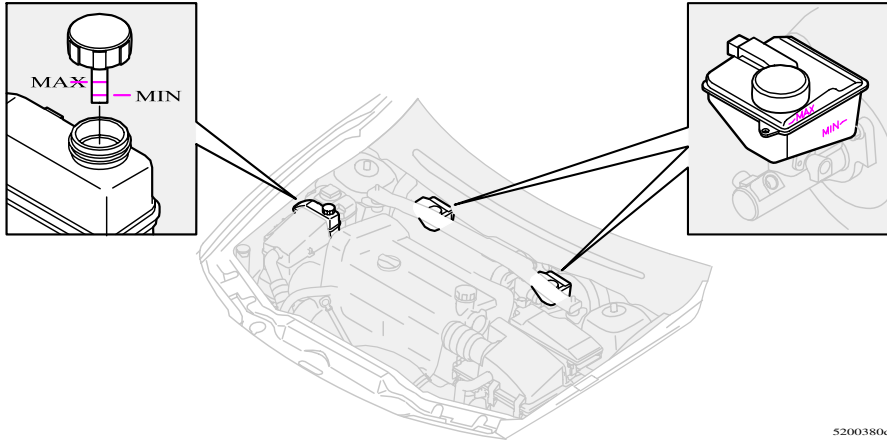

Power steering

The level should lie between the MIN and MAX marks.

Oil grade: Power steering fluid of type Pentosin CHF 11S or the like.

Check level at every service. Replacing the oil is not necessary.

Position: In engine compartment, see pages 124-125.

NOTE! If a fault occurs in the power steering (or if the car has no power and is to be towed) the car can still be steered. Remember that the steering will be much heavier than normal and more strength is required to turn the steering wheel.

Clutch and brake fluid reservoir

The brake and clutch have the same reservoir. The level should lie between the MIN and MAX marks.

Fluid type: Brake fluid DOT 4+.

Check level regularly

Change the fluid every other year or at every other regular service interval.

Position: In engine compartment, see pages 124-125.

NOTE! The fluid should be changed annually on cars which drive in conditions requiring hard and frequent braking, driving in mountains or tropical climates with high humidity. Replacement is not part of a service schedule but should be carried out in conjunction with a service at the Volvo workshop.

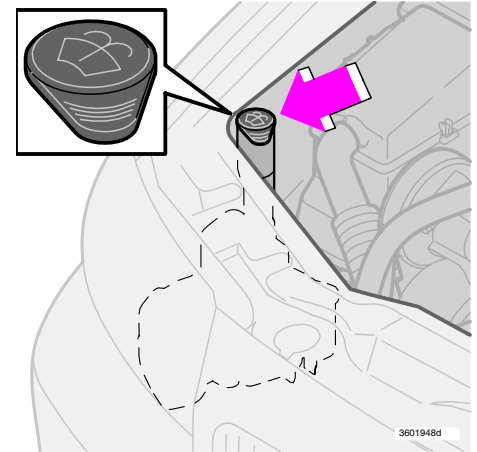

Washer fluid reservoir

Washer fluid reservoir

The wipers for the windscreen and headlamps share the same fluid reservoir. It is located under the bonnet and has a capacity of 4.5 litres. Use washer fluid during the winter so that the fluid does not freeze in the pump, reservoir and hoses.

Battery care

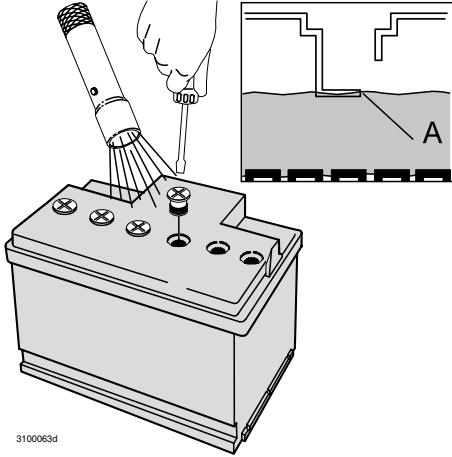

Battery

The function and life of the battery are affected by driving conditions, driving style, number of starts, climate conditions, etc. For the battery to function satisfactorily, you should consider the following:

- Regularly check that the battery fluid level is correct (A).
- Check **all** battery cells. Use a screwdriver to remove the cover. A flashlight is useful for checking the fluid level. Each cell has a maximum mark (A).

- If necessary: fill the battery with water to the maximum level in the battery.
NOTE! Do not fill above the maximum mark (A).
- Do not use normal tapwater. Use distilled or deionized water (battery water).
- If you wish to charge your battery for any reason, you must check the fluid level **after** charging and top up with water as needed.
- Ensure that the plugs are tight.

NOTE! The number of times the battery is run flat negatively affects its service life.

WARNING!



- Remember that the battery contain oxyhydrogen, which is highly explosive. An open flame or smoking new the battery is enough to cause the battery to explode and cause you injury and/or damage the car.
- The battery also contains sulphuric acid, which can cause serious corrosive damage. If the acid comes into contact with your eyes, skin or clothes, flush with large quantities of water. If acid splashes into your eyes contact a doctor immediately.

Symbols:



Use protective goggles.



Further information in the owner's manual.



Store the battery out of the reach of children.



The battery contains corrosive acid.



Avoid sparks and open flames.



Risk of explosion.

Battery care

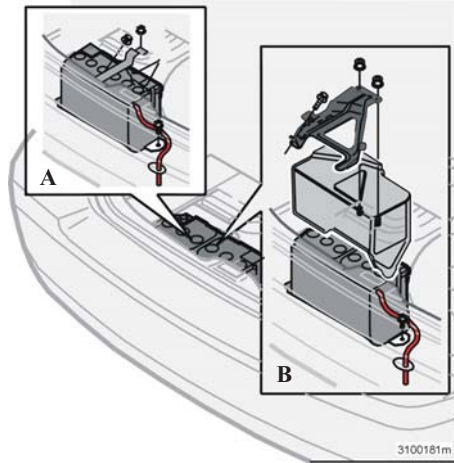

- Undo the nut from the lower bracket and remove the bracket.
- Lift out the old battery.
- Put the new battery in place.
- Fit the lower bracket and tighten the nut.
- Press the plastic cover of the positive battery terminal in place and connect the positive lead.
- Fold down the plastic cover over the positive terminal and then connect the negative lead.
- Make sure the evacuation hose is correctly connected to both the battery and the outlet in the bodywork.
- Fit the lock brace over the battery and tighten the bolts.

B. Battery with cover (see illustration)

Once you have unscrewed the bracket and the cover from over the battery, remove the battery as described in version A.

Replacing the battery

A. Battery without cover (see illustration)

- Check that the ignition is switched off.
- **Wait** at least 10 minutes before touching any electrical terminals (so that the information in the car's electrical system can be stored in the different control modules).
- Undo the bolts from the lock brace over the battery and remove the brace.
- **Disconnect the negative lead first.**
- Fold up the plastic cover over the positive terminal of the battery.
- Disconnect the positive lead and remove the plastic cover from the positive terminal.
- Detach the oxyhydrogen gas evacuation hose from the battery.

Important!

Repeated use of the parking heater and other great power consumers in combination with short trips can lead to battery discharge and thereby difficulty starting.

If great power consumers are used regularly, the car should be driven for the same amount of time as these consumers were connected in order to ensure that the generator is able to produce enough energy to compensate for the amount consumed.

WARNING!



Oxyhydrogen gas evacuation

The battery can develop oxyhydrogen gas, which is extremely explosive. To prevent oxyhydrogen gas from remaining in the cargo compartment, there is an evacuation hose that leads any oxyhydrogen gas from the battery out into the fresh air. If the battery must be replaced for some reason, make certain that the evacuation hose is connected to the new battery and it is run downwards to its intended outlet in the bodywork.

Replacing wiper blades

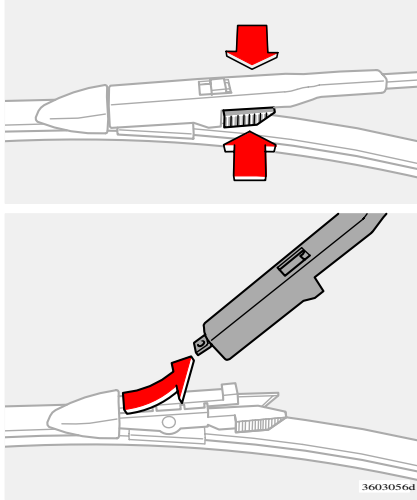

Replacing 'flatblade' windscreen wiper blades

- Fold out the wiper arm and hold the wiper blade.
- Push in the ribbed locking springs on the wiper blade while lifting it from the arm extension.
- Install the new blade following the instructions in reverse order and **check that the blade is properly secured.**

NOTE! Keep in mind that the wiper blade on the driver's side is longer than the blade on the passenger side.

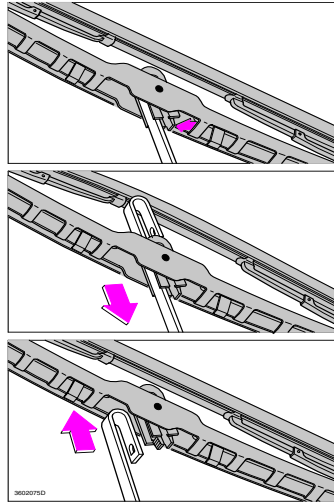

Replacing windscreen wipers of traditional type

- Fold out the wiper arm and hold the wiper blade at 45° to the wiper arm. Press in the spring on the wiper blade.
- Press the entire wiper blade down so that the wiper arm eye passes through the hold in the wiper blade mounting.
- Then pull the blade up so that the wiper arm eye passes beside the wiper blade mounting.
- Install the new blade in reverse order and **check that it is securely in place.**

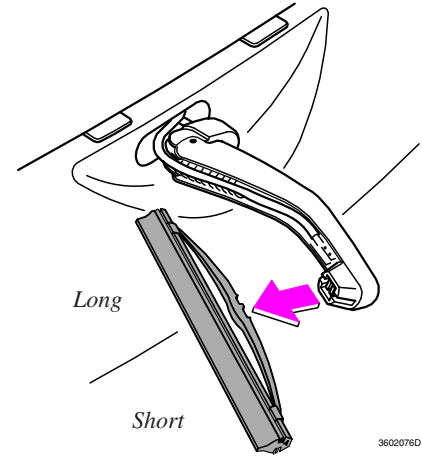

Replacing headlamp wiper

- Fold the wiper arm forward.
- Remove the wiper blade outwards.
- Press new wiper blade into position.
- Check that it is properly secured!

Specifications

Type designation	134
Weights and measurements, Capacities	135
Lubricants, Fluids, Oils	136
Power transmission	137
Electrical system	138
Engine	139

Specifications

Type designation

When contacting your Volvo dealer about your car and when ordering spare parts and accessories, it makes things easier if you know your car's type designation, vehicle identification number and engine number.

1 Type, model year designation and vehicle identification number

Stamped in the engine compartment beneath the windscreen.

2 Type designation, vehicle identification number, permitted weights and codes for paint and upholstery and type approval number.

Plate on the wing liner behind the left-hand headlamp.

3 Engine type designation, component and serial number

On the top side of the cylinder block.

4 Gearbox type designation, and serial number

a: Manual gearbox: on the front side

b: Automatic gearbox (AW55-50): on the upper side

c: Automatic gearbox (GM4T65EV): on the rear side

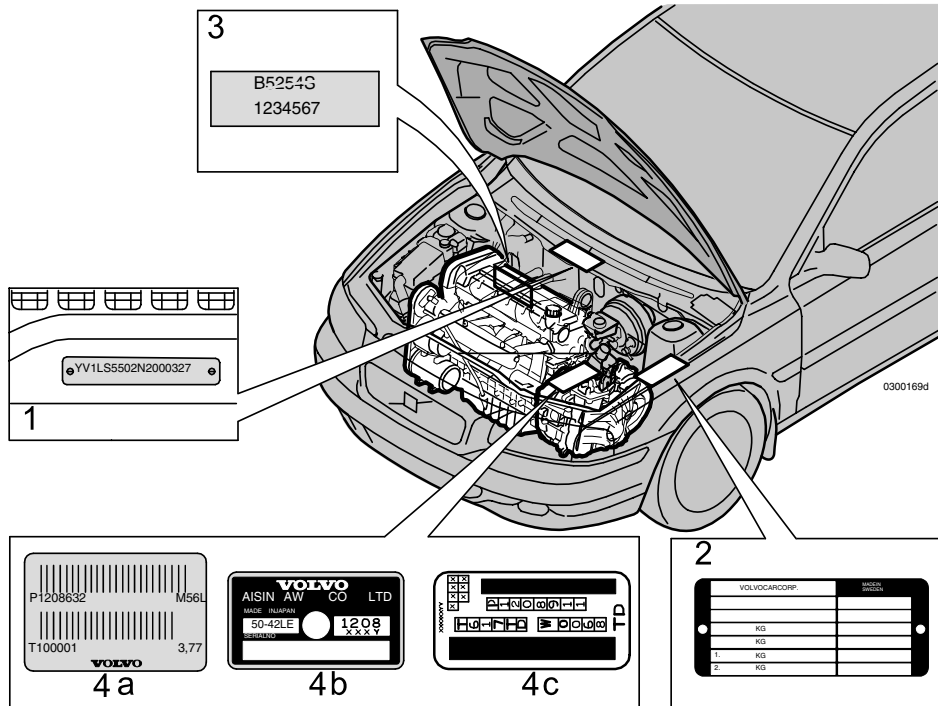

Weights and measurements, Capacities

Weights and measurements

Length	482 cm
Width	183 cm
Height	145 cm
Wheelbase	279 cm
Front track	158 cm
Rear track	156 cm

Permissible weight (excluding driver) = Total weight-kerb weight

Chassis data plate with weight specification on the plate in the engine compartment

1. Max. total weight

2. Max. train weight (car+trailer)

3. Max. front axle load

4. Max rear axle load Max load, see registration papers

Max roof load 100 kg

Maximum trailer weight 1800 kg

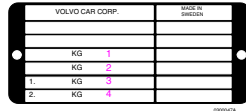

Capacities

Fuel tank 70/80 litres*

Engine oil (incl. filter change)**

B5204T5	approx. 5.5 litres
B5234T7	approx. 5.5 litres
B5244S (170 bhp)	approx. 5.5 litres
B5244S2 (140 bhp)	approx. 5.5 litres
B5254T2 2.5T	approx. 5.5 litres
B6294S2	approx. 6.5 litres
B6294T T	approx. 6.5 litres
D5244T D5	approx. 7.0 litres
D5244T2 2.4D	approx. 7.0 litres

Transmission oil

Manual	2.1 litres
Automatic	7.2 litres
Geartronic	7.5 litres

Power steering 0.9 litres

Windscreen washer reservoir 4.5 litres

Brake and clutch fluid 0.6 litres

Air conditioning (A/C) system 1000 grams

* Cars with 6-cylinder engines and all turbo models come with an 80 litre tank.

** : To verify which engine is in the car - see the type designation stamped into the engine compartment (previous page, point 3).

Important!

After changing the oil, use the dipstick to check that the engine has the correct amount of oil. Warm up the engine and then check the oil a few minutes after the engine is switched off.

Lubricants, Fluids, Oils

Engine

Petrol engines: ACEA A1

ACEA A3 grade oil can also be used.

Note that the same oil can comply with both ACEA A1 and ACEA B1, regardless of whether it is a mineral, semi-synthetic or fully synthetic oil

Diesel engines: ACEA B4

Note that the same oil can comply with ACEA A3, ACEA B3 and ACEA B4, regardless of whether it is a mineral, semi-synthetic or fully synthetic oil.

Do not use extra additives. These can damage the engine.

Volvo fully synthetic engine oil is recommended for turbocharged petrol and diesel engines.

Viscosity (assumes constant air temperature)

For extreme driving conditions that produce abnormally high oil temperatures or oil consumption, such as driving in mountainous terrain with a great deal of engine braking or high-speed motorway driving, oil grade **ACEA A3 (petrol engines) is recommended.**

NOTE! Oils with viscosity 0W-30 and 0W-40 must fulfil the requirements of ACEA A3 (petrol engines).

Gearbox

Oil grade:

- Manual: Use only Volvo's synthetic gearbox oil.
- Automatic: **Only** Volvo's gearbox oil part no 1161540-8. Do not mix with any other oil.
- Geartronic: Volvo's synthetic gearbox oil. (Oil that complies with the requirement specification for Dexron(r)-IIIG).

Power steering

Oil grade: Power steering fluid of type Pentosin CHF 11S or the like.

Volume: approx. 0.9 litre

Brake fluid

Fluid type: Brake fluid DOT 4+

Volume: approx. 0.6 litre

Important!

If in doubt about the correct oil grade - contact a Volvo workshop.

Cooling system

Type:	Closed, overpressure	
Volume:	Petrol 5-cyl without turbo	approx. 8.0 litres
	Petrol 5-cyl with turbo	approx. 9.0 litres
	Petrol 6-cyl without turbo	approx. 9.0 litres
	Petrol 6-cyl with turbo	approx. 9.5 litres
	Diesel	approx. 12.5 litres

The thermostat starts to open at 90°C

Refrigerant

Type:	R 134a
Oil:	PAG P/N=1161627-3

Power transmission

Fuel

Standard DIN 51600

The engine can be run with octane ratings of 91, 95 and 98 RON.

- 98 RON is recommended for maximum effect and minimum fuel consumption.
- 95 RON can be used for normal driving.
- 91 RON should only be used as an exception. However, the engine will not be damaged by this fuel grade.

Diesel

Standard SS-EN 590

Power transmission - Automatic gearbox

Electronically controlled automatic gearbox with five gears. Consists of a hydraulic torque converter and planetary gears.

Rear suspension

Independent suspension with individually sprung wheels with shock absorbers. The suspension consists of rear-facing trailer arms, upper and lower control arms, track rods and anti-roll bar.

Frontend

McPherson type spring strut. Unitary construction of shock absorbers and spring. Rack and pinion steering. Safety type steering shaft. The values apply to an unladen car with full tank, coolant and spare wheel.

Electrical system

Electrical system

12-volt system with voltage regulated alternating current generator. Single pole system in which the chassis and engine block are used as conductors. The negative pole is connected to the chassis.

Battery

Voltage	12V	12V	12V (Diesel)
Cold start capacity (CCA)	520 A/30 s	600 A/30 s	800 A*
Reserve capacity (RC)	90 min/25A	115 min/25A	115 min/25A

If you must replace your battery, be sure to replace it with a battery of **the same cold start capacity and reserve capacity** as the original (See the decal on the battery).

Generator max current	140A		
Starter motor , power	1.4 kW	1.7 kW	2.2 kW

* Cars with a parking heater are also equipped with an 800A battery.

Bulbs

Headlamps	
Bi-Xenon headlamp (option)	
Fog lamps	
Position lamps, front	
Direction indicators, front (yellow)	
rear (yellow)	
side (yellow)	
Position lamps, rear	
Reversing lamp	
Fog lamp, rear	
Numberplate lighting	
Courtesy lighting, rear	
Courtesy lighting, front	
Cargo compartment lighting	
Glovebox lighting	
Vanity mirror	
Ashtray, rear	
Side marker lamp	
Position (side marker) light	

Output

55W	H 7
35W	D2R
55W	H 1
5W	W 2.1x9.5 d
21W	PY
21W	PY
5W	W 2.1x9.5 d
5W	BA 15
21W	BA 15
21W	BA 15
5W	W 2.1x9.5 d
5W	W 2.1x9.5 d
5W	SV 8.5
5W	SV 8.5
3W	BA 9
1.2W	SV 5.5
1.2W	W 2x4.6 d
3W	W 2.1x9.5 d
5 W	W 2.1x9.5 d

Base

Engine specifications

Engine	B5204T5*	B5234T7*	B5244S* (170 bhp)	B5244S2* (140 bhp)	B5254T2* 2.5T FWD/AWD	B6294S2*
Output** [kW/rps]	132/88	147/83	125/100	103/75	154/83	144/87
[bhp/rpm]	180/5300	200/5000	170/6000	140/4500	210/5000	196/5200
Torque** [Nm/rps]	240/37-88	285/33-83	225/75	220/55	320/25-75	280/65
[kpm/rpm]	24.5/2200-5300	29.1/2000-5000	23.0/4500	22.5/3300	32.6/1500-4500	28.6/3900
No. of cylinders	5	5	5	5	5	6
Bore [mm]	81	81	83	83	83	83
Stroke [mm]	77	90	90	90	93.2	90
Cylinder displacement [dm ³ (l)]	1.98	2.32	2.44	2.44	2.52	2.92
Compression ratio	9.5:1	8.5:1	10.3:1	10.3:1	9.0:1	10.5:1
Spark plugs						
Electrode gap [mm]	0.7-0.8	0.7-0.8	1.2	1.2	0.7-0.8	1.2
Tightening torque [Nm]	30	30	30	30	30	30

To verify which engine is in the car - see the type designation stamped into the engine compartment (Type designations - page 134, point 3).

* **The engine can be driven with the octane ratings 91, 95, and 98 RON.**

- 98 RON is recommended for maximum effect and minimum fuel consumption.
- 95 RON can be used for normal driving.
- 91 RON should only be used as an exception. However, the engine will not be damaged by this fuel grade.

** : Output and torque as per testing standard EU 80/1269. For petrol engines, 98 octane is used for this test.

Fill with correct petrol

You car has a catalytic converter and may only be driven using unleaded petrol. Otherwise, the catalytic converter could be damaged.

Engine specifications

Engine	B6294T*	D5244T	D5244T2	B5244SG	B5244SG2
	T6	D5	2.4D	CNG (gas)	LPG (gas)
Output** [kW/rps] [bhp/rpm]	200/87 272/5200	120/67 163/4000	96/67 130/4000	103/97 140/5800	103/85 140/5100
Torque** [Nm/rps] [kpm/rpm]	380/30-83 38.8/1800-5000	340/29-50 34.7/1750-3000	280/29-50 28.6/1750-3000	192/75 19.6/4500	214/75 21.8/4500
No. of cylinders	6	5	5	5	5
Bore [mm]	83	81	81	83	83
Stroke [mm]	90	93.2	93.2	90	90
Cylinder displacement [dm ³ (l)]	2.92	2.40	2.40	2.44	2.44
Compression ratio	8.5:1	18.0:1	18.0:1	10.3:1	10.3:1
Spark plugs					
Electrode gap [mm]	0.7-0.8	-	-	1.2	1.2
Tightening torque [Nm]	30	-	-	30	30

* **The engine can be run with octane ratings of 91, 95 and 98 RON.**

- 98 RON is recommended for maximum effect and minimum fuel consumption.
- 95 RON can be used for normal driving.
- 91 RON should only be used as an exception. However, the engine will not be damaged by this fuel grade.

** : Output and torque as per testing standard EU 80/1269. For petrol engines, 98 octane is used for this test.

Fill with correct petrol

You car has a catalytic converter and may only be driven using unleaded petrol. Otherwise, the catalytic converter could be damaged.

Audio

Overview HU-401	142
Overview HU-601	143
Overview HU-801	144
Radio functions	145
Cassette deck	152
CD player	153
Dolby Surround Pro Logic	156
Technical data - Audio	158

Audio system HU-401

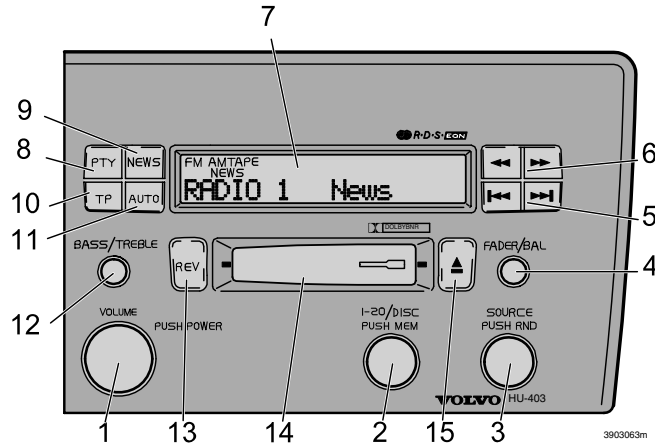

- | | | |
|--|---|--|
| <p>1. On/Off - press
Volume - turn</p> <p>2. Selector knob:
Stored radio stations
CD changer (option)</p> <p>3. Selector knob for:
Radio - FM, AM
Cassette
CD changer (option)
TV (option)</p> | <p>4. Fader - press and turn
Balance - press, pull and turn</p> <p>5. Radio - station seek up/down
Cassette - select next/previous track</p> <p>6. Radio - manual station selection
Cassette - fast forward/rewind</p> <p>7. Display</p> <p>8. Programme type</p> <p>9. News /Radio text</p> | <p>10. Traffic information</p> <p>11. Automatic station pre-setting</p> <p>12. Bass - press and turn
Treble - press, pull and turn</p> <p>13. Tape direction selector</p> <p>14. Cassette opening</p> <p>15. Cassette eject</p> |
|--|---|--|

Audio system HU-601

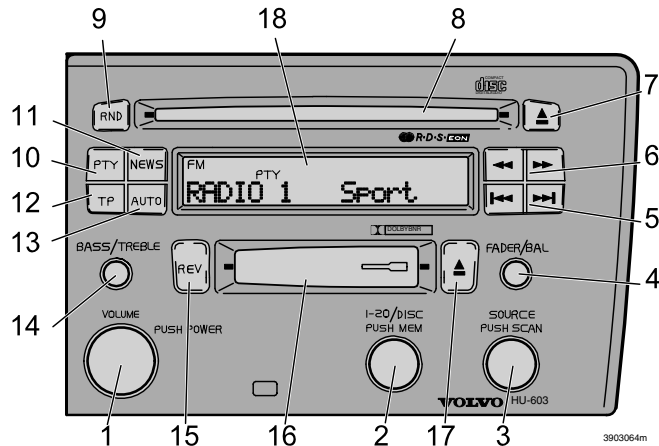

- | | | |
|--|--|---|
| <p>1. On/off (press)
Volume (turn)</p> <p>2. Selector knob:
Stored radio stations
CD changer (option)</p> <p>3. Selector knob:
Radio
Cassette
CD
CD changer (option)
TV (option)</p> | <p>4. Fader - press and turn
Balance - press, pull and turn</p> <p>5. Radio - station seek up/down
Cassette - selecting next/previous track
CD - selecting next/previous track</p> <p>6. Radio - manual station selection
Cassette - fast forward/rewind
CD - fast forward/rewind</p> <p>7. CD eject</p> <p>8. CD opening</p> <p>9. CD random</p> | <p>10. Programme type</p> <p>11. News/Radio text</p> <p>12. Traffic information</p> <p>13. Automatic station pre-setting</p> <p>14. Bass - press and turn
Treble - press, pull and turn</p> <p>15. Tape direction selector</p> <p>16. Cassette opening</p> <p>17. Cassette eject</p> <p>18. Display</p> |
|--|--|---|

Audio system HU-801

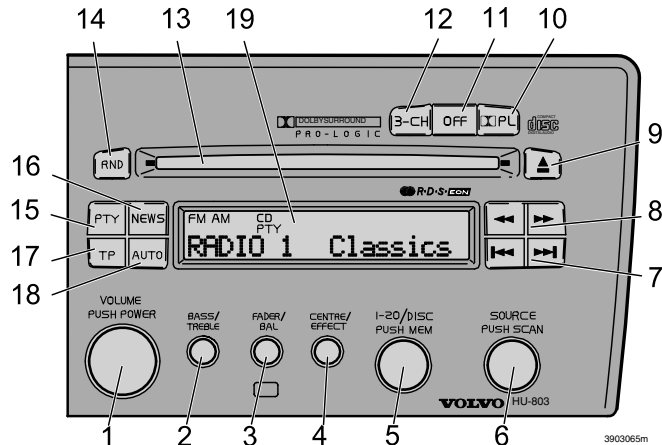

- | | | |
|---|--|--|
| <p>1. On/off (press)
Volume (turn)</p> <p>2. Bass - press and turn
Treble - press, pull and turn</p> <p>3. Fader - press and turn
Balance - press, pull and turn</p> <p>4. Centre volume - press and turn
Output volume - press, pull and turn</p> <p>5. Selector knob for:
Stored radio stations
Internal CD changer
External CD changer (option)</p> | <p>6. Selector knob for:
Radio
CD
CD changer (option)
TV (option)</p> <p>7. Radio - station seek up/down
CD - selecting next/previous track</p> <p>8. Radio - manual station selection
CD - fast forward/rewind</p> <p>9. CD eject</p> | <p>10. Dolby Pro Logic</p> <p>11. 2-channel stereo</p> <p>12. 3-channel stereo</p> <p>13. CD opening</p> <p>14. CD random</p> <p>15. Programme type</p> <p>16. News</p> <p>17. Traffic information</p> <p>18. Automatic station pre-setting</p> <p>19. Display</p> |
|---|--|--|

Radio functions

Volume control - TP/PTY/NEWS

If a cassette or a CD is playing when the radio receives traffic information, news, or a selected programme type, the function is interrupted, and the message will be heard

at the pre-set volume for traffic information, news or programme type. Volume is adjusted with the volume control.

The unit will thereafter return to the previously set volume and continue playing the cassette or the CD.

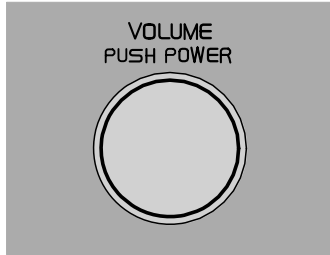

3902418d

On/Off switch

Press button to switch the radio on or off.

Volume control

Turn the knob clockwise to increase volume.

Volume control is electronic and does not have an end stop. If you have a keypad in the steering wheel, increase or decrease volume with the + or - buttons.

Volume control for integrated telephone (option)

If the telephone should ring while the radio is playing, the volume automatically lowers while the call is taken. When the conversation is concluded volume will return to its previous set level. The volume can also be adjusted during the call so that the new volume level is kept after the call. When in active mode, telephone information is always shown in the display.

This function only applies to the Volvo integrated telephone system.



3901856d

Bass

Set the bass by pressing out the button and turning to right or left. In the centre position the volume is “normalised”. Press the button back to original position after setting.

Treble

Set the treble by pressing out the button, pull it further out and turn it left or right. In the centre position the volume is “normalised”. Press the button back to original position after setting.

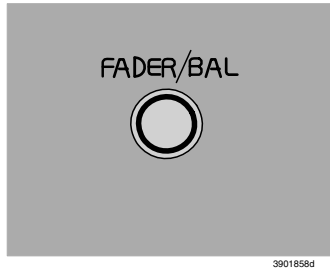

Fader - Balance front/rear

Set a suitable balance between the front and rear loudspeakers by pressing out the button and then turning it to the right (sound to front) or to the left (sound to the rear). Centre position means that the balance is "normalised". Press the button back to its original position after setting.

Balance right/left

Set the balance by pressing, pulling out the button and turning to right or left. In the centre position the volume is "normalised". Press the button back to its original position after setting.

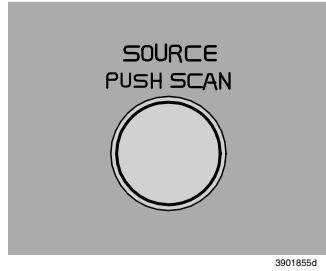

Wavelength selector

Turn **SOURCE** knob to select FM or AM. The station and wavelength are displayed. You can also select cassette deck, CD or CD changer, if connected, with this knob.

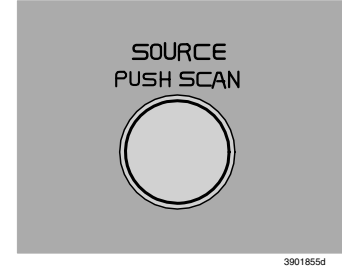

Scanning

Press the **SOURCE** knob to start scanning. When the radio finds a station, it stops scanning for a few seconds. It then resumes scanning. When it has found a station you wish to listen to, press the **SOURCE** knob. If the audio system is in cassette mode (HU-401, 601), each track is played for a few seconds. If the system is in CD mode (HU-601/801), each track will be played for a number of seconds. When it has found a song or track to which you wish to listen, press the **SOURCE** knob.

A

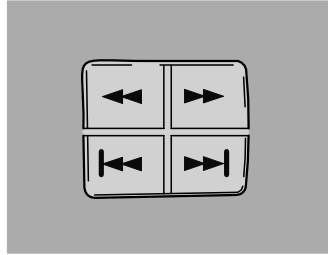

3901859d

B

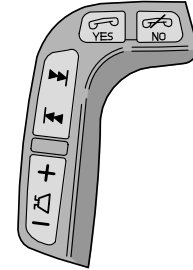

3901873d

A - Setting station

Press the left button to select a lower frequency and the right button for a higher frequency. Set frequencies are displayed.

B - Station seek up/down

Press the left or right-hand side of the button to seek lower or higher frequencies. The radio seeks the next audible station and sets it. Press the button again to continue seek.

Steering wheel keypad

If you have a keypad in the steering wheel, press the right or left arrow to select preset stations.

NOTE! If the car is equipped with an integrated telephone, the steering wheel keypad can only be used for telephone functions when the telephone is activated. When in active mode, telephone information is always shown in the display. Deactivate the telephone by pressing .

Switch off the telephone if you do not have an SIM card. See page 162.

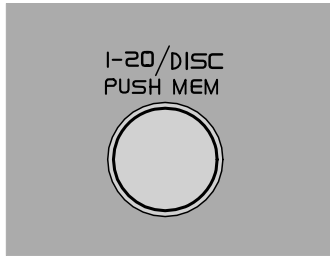

3901854d

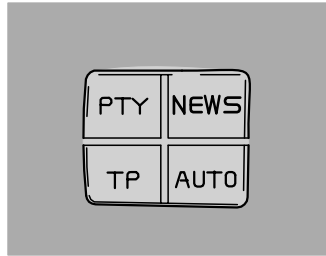

3901860d

Programming stations

1. Set the desired frequency.
2. Press the **1-20/DISC** button with a short push. Select a number by turning forwards or backwards. Press again to store the desired frequency and station.

Preset

To choose a preselected radio programme, turn the **1-20/DISC** button to the stored number. The set programme is displayed.

AUTO - Automatic station pre-setting

This function automatically seeks and stores up to 10 strong AM or FM stations in a separate memory. This function is especially useful in areas where you are not familiar with the radio stations.

1. Press and hold the **AUTO** button for at least 2 seconds. A number of stations with strong signals (maximally 10) from the set wavelength are now automatically stored in the memory. "AUTO" is displayed. If there is no station with sufficient signal strength, "NO STATION" is displayed.

2. Turn the **1-20/DISC** button if you wish to change to another of the preset stations. A new station is set with every turn (A0 - A9).
3. To once again choose from programmed settings, press **AUTO** again. **AUTO** will disappear from the display.

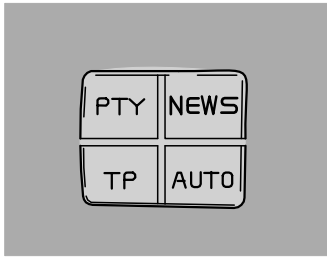

3901860d

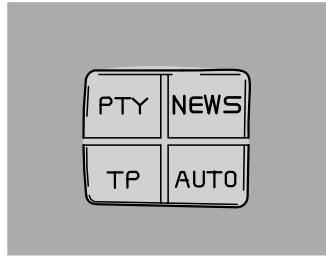

3901860d

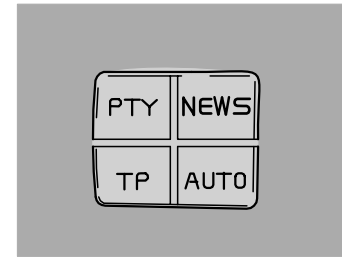

3901860d

Traffic information (TP)

A short push on the **TP** button (less than 2 seconds) gives the traffic information from RDS stations. "TP" is displayed when the function is connected. When the unit is in cassette or CD mode in the background, the radio automatically seeks an FM station with a strong signal which sends traffic information. If the cassette or CD is playing when the radio receives a traffic bulletin, the function is interrupted and the bulletin is broadcast with the volume selected for traffic information. As soon as the bulletin is over, the system returns to the previously set volume and resumes playing the cassette or CD.

- Traffic information can only be heard when **TP** and TP are displayed at the same time.
- If only TP is displayed it means that no traffic information is being broadcast by the current broadcaster.

- If you do not wish to listen to an ongoing traffic bulletin, press the **TP** button. The TP function, however, is still connected and the radio waits for the next traffic bulletin.
- Press the **TP** button to switch off the TP function. TP will no longer be shown in the display.

News on/off

A short press on the **NEWS** button activates the news function. The text NEWS is shown with small letters in the display. Press the **NEWS** button again to switch off the function. As soon as the news broadcast starts, the cassette, CD or CD changer is interrupted so the news can be heard.

If you do not wish to listen to the news programme when it is sent, press the **NEWS** button. The current programme is interrupted.

The news function, however, is still connected and the radio waits for the next news broadcast. Press **NEWS** again to switch off the function. NEWS then disappears from the display.

Radio text

Some RDS stations send information about programme content, artists, etc. This information is shown in text form in the display. Push the **NEWS** button for a few seconds to access any transmitted radio text, which is then shown in the display. A short press on the **NEWS** button will end the display of radio text.

Programme types	Displayed
New features	New features
Current affairs	Current
Information	Info
Sport	Sport
Education	Educ
Theatre	Theater
Culture and Art	Culture
Science	Science
Entertainment	Enterta
Pop music	Pop
Rock music	Rock
Easy listening	Easy list
Light classical	L Class
Classical music	Classical
Other music	Other M
Weather	Weather
Economy	Economy
For children	For children
Social questions	Social
Spiritual questions	Spiritual
Telephone watch	Telephone
Travel and holiday	Travel
Leisure and hobby	Leisure
Jazz music	Jazz
Country music	Country
National music	Nation M
Golden oldies	“Oldies”
Folk music	Folk
Documentary	Document
Alarm test	Alarm test
!!ALARM!!	!!Alarm!!
PTY missing	Pty Miss

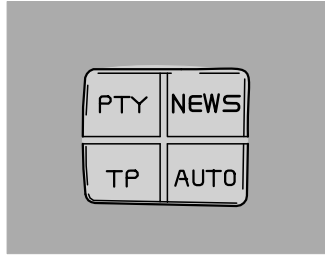

Programme type

The PTY function allows you to directly select programmes with different subject types. Seek a certain programme type as follows:

1. Press the **PTY** button. The programme type of the set station is shown in the display.
2. You can scroll through the list of programme types by turning the **1-20/DISC** knob.
3. Once you have found the desired programme type, press the **1-20/DISC** knob to confirm your selection and start the search.
4. If the radio finds a station with the selected programme type, it sets it. If the radio finds no station with the selected programme type, it will return to its previous function. PTY is then in standby mode and remains so until a programme of the selected type begins. The radio then changes to the station with the selected programme type.
5. If there is more than one station with the selected programme type, you can select using or the **SCAN** button. The PTY

function is active until the radio finds the selected programme type and as long as the selected station transmits that programme type.

6. To return to standby mode, press PTY again. The CD or cassette will resume playing until the selected programme type is sent again.
7. Press PTY once again to deactivate PTY standby. The PTY symbol goes out.

Advanced User Mode

- With the radio switched off, press and hold the Volume knob at least 5 seconds to start the AUM function.
- Turn the **1-20/DISC** button to select an AUM function (see the function list to the right).
- Once you have selected a function, the function's default will blink. Press the **1-20/DISC** knob to select other alternatives of the function (ON/OFF, LOW/MID/HIGH, etc., depending on the function).
- Continue selecting functions/alternatives.

To *restore* all AUM functions to factory settings, turn the **1-20/DISC** button until “**SET TO DEFAULT**” shows in the radio display. Then press the same button. All AUM settings are then restored to their defaults and the radio returns to its normal mode (music, news, etc.).

To *save* any changes and return to the normal mode, turn the **1-20/DISC** knob until “**BACK and SAVE**” is shown in the radio display. Then press the same dial. Confirm by pressing the **1-20/DISC** knob once again.

To return to normal mode *without saving* any changes, turn the **1-20/DISC** knob until “**BACK without SAVE**” is shown in the radio display. Then press the same knob. Confirm by pressing the **1-20/DISC** knob once again.

List of AUM functions

(**default is underlined**)

- SET TO DEFAULT (See left column).
- AF SWITCHING ON/OFF (Automatic frequency update) – The AF function makes sure that the strongest available transmitter for a chosen programme is used.
- REGIONAL ON/OFF (Regional radio programmes) – This function makes it possible to stay tuned to a regional transmitter even if the signals are not very strong.
- EON (Enhanced Other Networks)
- LOCAL/DISTANT – This function is used to indicate if the radio programme you are listening to is to be interrupted for traffic messages or news broadcasts (if these functions are selected) only if the signal is strong (LOCAL) or if the radio should also try to pick up weaker signals (DISTANT).
- NETWORK ALL/TUNED – This function is used to indicate if the radio programme you are listening to is to be interrupted for traffic messages or news broadcasts (if these functions are selected) only if the message comes from the channel you are listening to, such as P1 (TUNED), or if the programme is to be interrupted regardless of which radio channel the message/broadcast comes from (ALL).
- LANGUAGE – Select which language is to be used in the radio display (English, German, French or Swedish). Only works for PTY information.
- ASC (Active Sound Control) ON/OFF (active volume control) – The ASC function automatically adjusts the radio volume according to the speed of the car.
- ASC TABLE – Choose a level for the ASC function (LOW/MID/HIGH).
- SRC ON/OFF – This is used to activate/deactivate the function that reduces the treble when reception is poor. This might seem like improved reception.
- SRC TABLE - Choose a level for the SRC function (LOW/MID/HIGH).
- TAPE DOLBY ON/OFF – Activate/deactivate Dolby Noise Reduction when you listen to a cassette (HU 401/601).
- BACK and SAVE (See left column).
- BACK without SAVE (See left column).

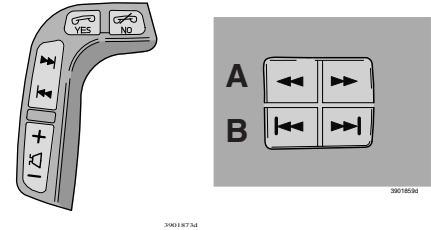
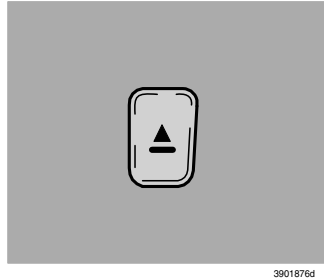
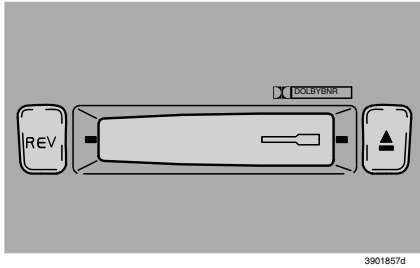

Cassette opening

Slide cassette into the cassette opening with the tape to the right. TAPE Side A is shown in the display. When one side has finished playing the system will automatically begin playing the other side (auto reverse). If a cassette is already installed in the cassette deck select cassette play by turning the **SOURCE** knob.

Changing tape direction

Press the **REV** button to if you wish to play the other side of the tape. The display shows which side is being played.

Cassette eject

If you press the button, the tape stops and the cassette is ejected. Turn the **SOURCE** knob to select a new programme source. The cassette can be inserted or ejected even if the system is switched off.



Dolby B Noise Reduction

This function is preset. Do as follows to switch it off: hold the **REV** button depressed until the Dolby symbol  in the display goes out. Press the same button again to reactivate the Dolby function.



Scanning (HU-601)

See page 144 for more information.

A - Fast forward/rewind

The tape can be wound forward with  and backwards with . During fast forward/rewind “FF” (forward) respectively “REW” (backward) is displayed. Fast forward/rewind is interrupted if you press the button again.

B - Next track, Previous track

If you press in the  button, the cassette is automatically wound forward to the next track. If you press  in the button, the cassette is automatically rewound to the previous track. There must be a five second break between each track for this function to work. If you have a keypad in the steering wheel, you can use the arrows.

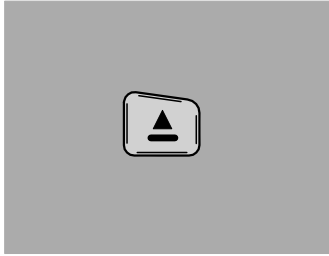

CD player

Insert a CD. If this was already done, select CD by turning the **SOURCE** knob.

CD eject

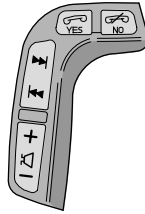

If you press this button the CD stops playing and the disc is ejected. (See illustration above)
NOTE: For traffic safety reasons you have twelve seconds to handle the ejected CD. The CD player then pulls it back in and continues play.



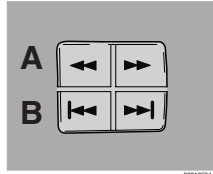

3901873d



A - Fast forward/rewind

Press  or  to seek within a track.

B - Changing tracks

Press  to skip to the next track or  to skip to the previous track. The track number is shown in the display. If you have a keypad in the steering wheel, you can use the corresponding buttons.

Scanning

See page 146 for more information.

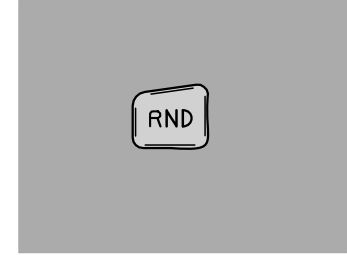

Random

Press **RND** to connect the random function. The unit plays tracks from the disc in random order. "RND" (random) is displayed as long as the function is activated.

Important!

Never use CD discs that have had a disc label attached. The heat generated in the CD player can result in the label on the disc releasing. And in doing so there is risk of damaging the CD player.

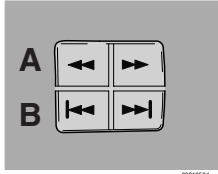
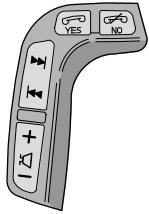

3901875d

3901875d

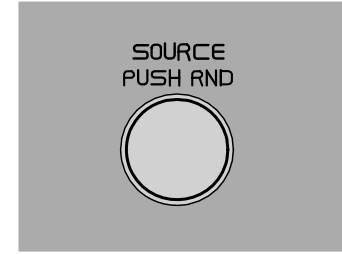
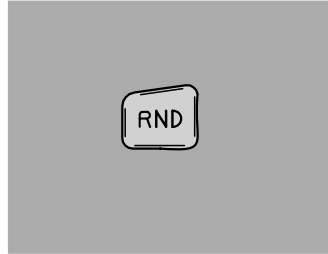

3901875d

CD changer



Turn the **SOURCE** knob to activate CD changer mode. The CD changer resumes playing the disc and track that was playing last. If the CD changer magazine* is empty “LOAD CARTRIDGE” is displayed.

Selecting disc number



Turn the **1-20/DISC** knob. The numbers of the disc and the track are shown in the display.

* The CD changer function can only be used if the unit is connected to the Volvo CD changer which is standard on certain models and available as an accessory on others.

A - Fast forward/rewind

Press  or  to seek within a track.

B - Changing tracks

Press  to skip to the next track or  to skip to the previous track. The disc and track numbers are shown in the display. If you have a keypad in the steering wheel, you can use the corresponding buttons.

Scanning (HU-601 801)

See page 146 for more information.

Random

Press **RND** (for HU-601 and 801) to connect the random function. If you have radio HU-401 press the **SOURCE** knob. A randomly selected track is chosen from a randomly selected disc. Then a new track is selected in the same way. “RND” (random) is displayed as long as the function is activated.

NOTE! Use only CD discs with Ø 12 cm. Do not play CD discs with smaller dimensions!

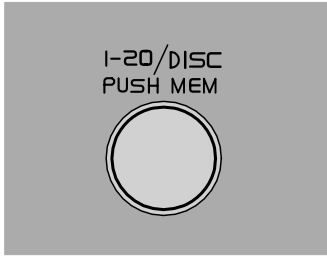

3901854d

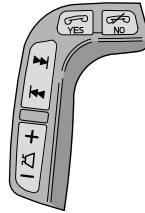

3901877d

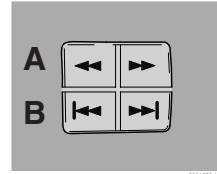

3901854

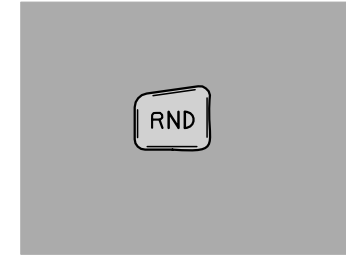

External CD changer

HU-801 includes an internal 4 disc CD changer. Turn the **SOURCE** knob to activate the CD player. The CD player resumes playing the disc and track last played. You can insert 4 discs in the CD player. To insert a new disc, you must have an available position in the player. Turn the **1-20/DISC** knob to find an available position. Make sure that "LOAD DISC" is displayed before inserting a new disc.

CD eject

If you press this button the CD stops and the disc that was playing is ejected.

NOTE: For traffic safety reasons you have twelve seconds to handle the ejected CD. The CD player then pulls it back in and continues play.

Selecting disc number

Turn the **1-20/DISC** knob. The numbers of the disc and the track are shown in the display.

A - Fast forward/rewind

Press or to seek within a track.

B - Changing tracks

Press to skip to the next track or to skip to the previous track. The disc and track numbers are shown in the display. If you have a keypad in the steering wheel, you can use the corresponding buttons.

Scanning (HU-801)

See page 146 for more information.

Random

Press **RND** to connect the random function. A randomly selected track is chosen from a randomly selected disc. Then a new track is selected in the same way. "RND" (random) is displayed as long as the function is activated.

NOTE! If the quality of the CD does not comply with the standard EN60908, or if it has been recorded using poor equipment, sound quality may be poor or playback interrupted.

Important!

Never use CD discs that have had a disc label attached. The heat generated in the CD player can result in the label on the disc releasing. And in doing so there is risk of damaging the CD player.

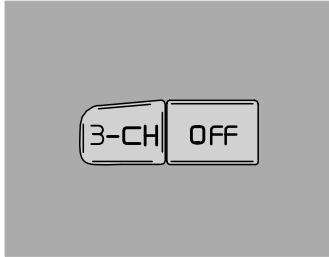

3901877d

Dolby Surround Pro Logic

Dolby Surround Pro Logic together with a centre loudspeaker in the dashboard offers you a sound experience very close to reality. The normal left - right stereo channels are divided to left - centre - right. In addition, ambient surround sound is produced by the rear loudspeakers. This ambient surround sound mirrors the resonance in the recording studio.

Most recordings today are made so that the vocalist/soloist is heard from straight ahead while the orchestra is heard over the entire left-right panorama and from behind. The result with Dolby Surround Pro Logic is a sound experience very close to being there. Note that the sound experience for rear seat passengers when using Dolby Surround Pro Logic is different than that of the driver and front seat passenger.

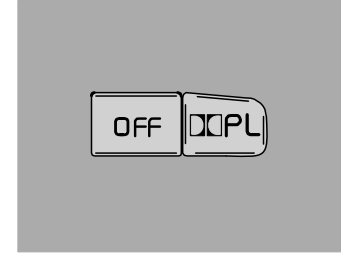

3901878d

Dolby Surround Pro Logic Mode*

To select Dolby Surround Pro Logic Mode press “**DOLBY PL**”. “Dolby Pro Logic” is displayed. Press **OFF** to return to 2-channel stereo.

* Dolby Surround Pro Logic Mode works in CD, cassette and FM modes. If you are listening to a radio transmission, you should instead select 3-channel stereo (3-CH).

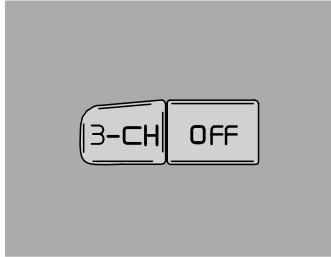

3-channel stereo

To select 3-channel stereo press “**3-CH**”. “**3-CH**” is displayed. Press **OFF** to return to 2-channel stereo.



Centre loudspeaker volume

Set the centre loudspeaker volume by pressing out the button and turning it left or right. In the centre position the volume is “normalised”. Press the button back after setting.



Rear loudspeaker output level (surround sound)

Set the power output of the rear channels by pressing out the button, pulling it further out and turning it left or right. In the centre position the power output is “normalised”. Press the button back after setting. This control regulates the surround speaker level when using Dolby Surround Pro Logic.

Technical data - Audio

HU-401

Output: 4 x 25 W
Impedance: 4 Ohm
Voltage required: 12 V, negative ground

Radio

Frequency: U (FM) 87.5 - 108 MHz
M (AM) 522 - 1611 kHz
L (AM) 153 - 279 kHz

HU-601

Output: 4 x 25 W
Impedance: 4 Ohm
Voltage required: 12 V, negative ground
External amplifier: 4 x 50 W or 4 x 75 W (option)

Radio

Frequency: U (FM) 87.5 - 108 MHz
M (AM) 522 - 1611 kHz
L (AM) 153 - 279 kHz

Bass speaker

Built-in amplifier: 150 W

Alarm

“Alarm!” is shown in the radio display when an alarm message is transmitted. The function is used to warn the driver of serious accidents or catastrophes, such as collapsed bridges, earthquakes or nuclear accidents.

Dolby Noise Reduction is manufactured under license of Dolby Laboratories Licensing Corporation. Dolby and the double D symbol  are trademarks of Dolby Laboratories Licensing Corporation.

Dolby Surround Pro Logic is a trademark of Dolby Laboratories Licensing Corporation. Manufacturing rights for Dolby Pro Logic Surround System are licensed from Dolby Laboratories Licensing Corporation.

HU-801

Output: 1 x 25 W (Centre speaker)
Impedance: 4 Ohm
Voltage required: 12 V, negative ground
External amplifier: 4 x 50 W or 4 x 75 W (option)

HU-801 must be connected to an external amplifier.

Radio

Frequency: U (FM) 87.5 - 108 MHz
M (AM) 522 - 1611 kHz
L (AM) 153 - 279 kHz

Telephone (option)

Telephone system	160
Operating	162
Call options	163
Memory functions	166
Menu functions	167
Miscellaneous information	171

Telephone system

General rules

- **Put traffic safety first!** If you as the driver must use the privacy handset in the armrest, park the car in a safe place.
- Switch off the system when refuelling the car.
- Switch off the system near blasting work.
- Let only authorised personnel service your telephone system.

Emergency calls

Emergency calls to emergency services can be made without the ignition key or the SIM card.

- Press the ON/OFF button.
- Ring the emergency number that applies to your region (within EU: 112).
- Press the green button  .

1. Keypad in centre console

All telephone system functions can be controlled from the keypad in the centre console.

2. Steering wheel keypad

The keypad in the steering wheel can be used for most telephone system functions. When the telephone is activated, the keypad in the steering wheel can only be used for telephone functions. When in active mode, telephone information is always shown in the display. To use the buttons for radio settings, the telephone has to be deactivated, see page 162.

3. Display

The display shows menu functions, messages, telephone numbers, etc.

4. Privacy handset

The privacy handset can be used for private conversations when you do not wish to be disturbed.

5. SIM card

The SIM card is inserted in the front of the centre console keypad. Switch off and deactivate the telephone if no SIM card is inserted, otherwise messages from other functions cannot be displayed.

6. Microphone

The microphone is built into the rearview mirror.

7. Loudspeaker

The loudspeaker is built into the driver's seat head restraint.

8. Antenna

The antenna is mounted against the windscreen in front of the rearview mirror.

Telephone

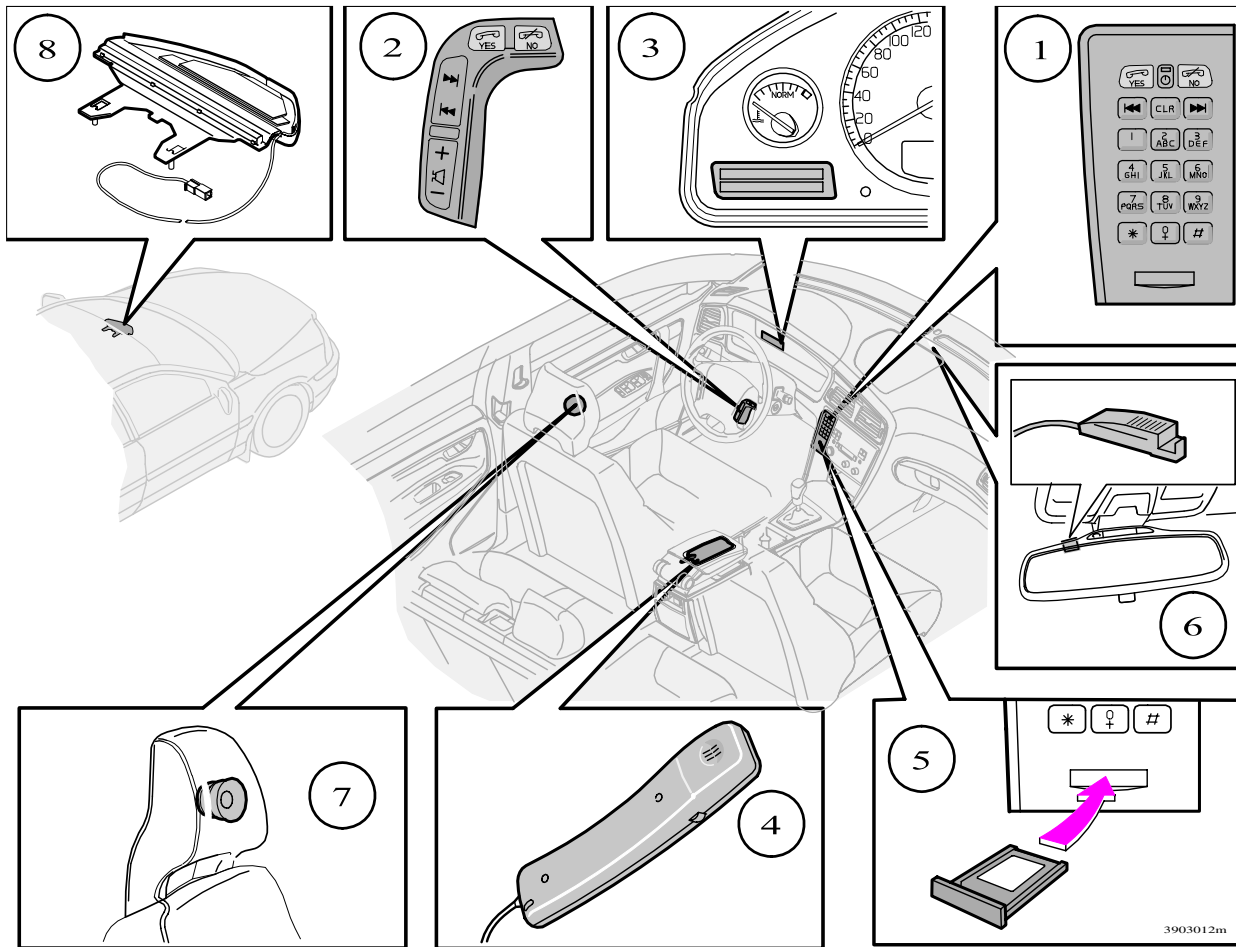

Operating

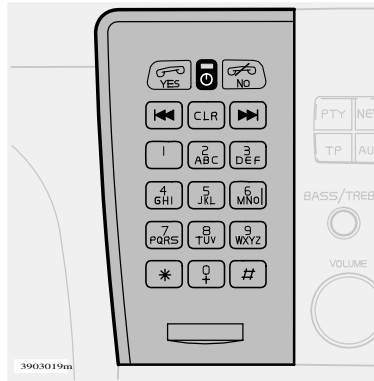
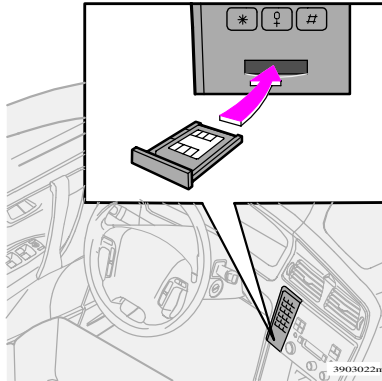

SIM card

The telephone can only be used in conjunction with a valid SIM card (Subscriber Identity Module). Obtain the card from your service provider.

Always insert the SIM card to use the telephone. The name of your service provider will then be displayed.

Switch off and deactivate the telephone if there is no SIM card inserted. Otherwise, messages from other functions cannot be shown in the display and the steering wheel keypad cannot be used for the radio.

Switching the system on and off

To switch the system on: Turn the ignition key to position I. Press the button marked in the illustration.

To switch the system off: Press the same button a few seconds. If you switch off the car ignition without first switching off the telephone, the telephone will be on the next time you turn on the ignition.

Telephone calls cannot be received if the telephone system is switched off.

Active mode

A prerequisite for using the telephone system functions is that the telephone must be in its active mode (does not apply for receiving calls).

Activate the telephone by pressing  on the centre console keypad or the keypad in the steering wheel.

When in active mode, telephone information is always shown in the display.

Press  to deactivate the telephone.

Call options

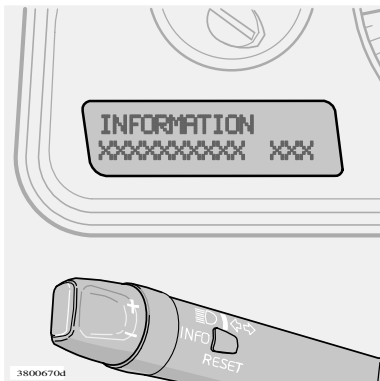

Display

The display shows the current function, such as menu alternative, message, telephone number, or setting.

Making and receiving calls

To **place a call**: enter the number and press  on the steering wheel or centre console keypad (or lift up the handset).

To **receive** an incoming call: Press the button  (or lift the privacy handset). You can also use Automatic answer, see menu function 4.3.

The audio system is automatically muted during conversation. See menu alternative 5.6.5 regarding audio system volume.

Ending a call





To conclude a call, press  on the steering wheel or centre console keypad or put the handset back in place. The audio system will resume its previous activity.

Call options (cont.)



Last number called

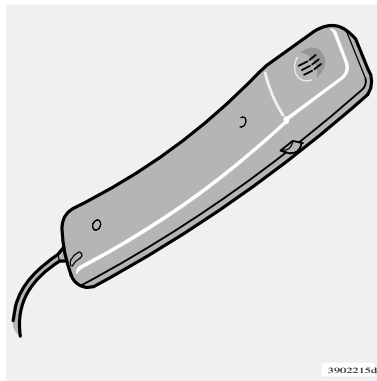

The telephone automatically stores the last telephone numbers/names called.

1. Press  on the steering wheel or centre console keypad.
2. Use the arrows to scroll forward  or backward  through the last numbers called.
3. Press  (or lift the privacy handset) to make the call.



Privacy handset





If you wish to talk undisturbed, use the **privacy handset**.

1. Pick up the handset. Enter the chosen number on the centre console keypad. Press  to place a call. Adjust the volume by using the knob on the side of the handset.
2. The call is terminated when you replace the handset in its holder.
If you wish to change to handsfree without ending the call: press  and select Handsfree. Press  and put down the handset, see the following page.

Speed dial

Storing speed dial numbers

A number stored in the telephone book can be linked to a speed dial button (0-9) as follows:

1. Go into active mode. Scroll with  to Edit memory (Menu 3) and press .
2. Scroll to Speed dial (Menu 3.4) and press .
3. Choose the digit that is to be the speed dial number. Press  to confirm.
4. Find the desired name or telephone number in the memory and press  to select it.

Using speed dial

Press the desired speed dial button for about 2 seconds to make a call.

NOTE! When you turn on the telephone, wait a moment before using the speed dial function. To enter a speed dial number, Menu 4.5 must be activated, see page 168.

Telephone

Functions during a call

The following functions are available **during** a call (scroll with arrows):

Secret mode/ Secret mode off	Secret mode
Hold/No hold	Choose if the present call is to be parked, i.e. put on hold
Handset/ Handsfree	Use the handset or handsfree
Memory	Show stored numbers

The following functions are available when you have **a current** call and **a parked** call (scroll with arrows):

Secret mode/ Secret mode off	Secret mode
Handset/ Handsfree	Use the handset or handsfree
Memory	Show stored numbers
Three-way calling	Speak with both parties simultaneously (conference call)
Switch	Switch between the two calls

The following functions are available during **three-way calling** (scroll with arrows):



Secret mode/ Secret mode off	Secret mode
Handset/ Handsfree	Use the handset or handsfree
Memory	Show stored numbers

Call waiting

If you hear a beep in your receiver followed immediately by two beeps (double beep) during a phone call, someone else is calling. The double beep is then repeated until you either answer or the caller hangs up.

In this mode, you can choose to either take the call or ignore it.

If you **do not** wish to take the call, press  or do nothing.

If you **do** wish to take the call, press . Your current call will be put in “park mode”. If you press , both calls will be terminated.

SMS

A double beep informs you that a SMS-message has been received.



Volume

Increase volume by pressing on the (+) button on the steering wheel keypad. Reduce volume by pressing on the (-) button.

When the telephone has been activated, the steering wheel keypad can only be used for telephone functions.

To use this keypad for radio settings the telephone has to be deactivated, see page 160.

Memory functions

Telephone numbers and names can be stored in either the telephone memory or the SIM card memory.

If the number of the person calling is in the memory, their name is shown in the display.

Up to 255 names can be stored in the telephone memory.

Storing telephone numbers with names

1. Press and scroll to Edit memory (Menu 3) and press .
2. Scroll to Enter item in memory (Menu 3.1) and press .
3. Enter a number and press .
4. Enter a name and press .
5. Choose in which memory to save with and press .

Enter a name (or message)

Press the button with the desired character: once for the first character, twice for the second, etc. Press 1 to enter a space.

space 1- ? ! , . : ' ()

a b c 2 ä å à á â æ ç

d e f 3 è é ê

g h i 4 ì í î ï

j k l 5

m n o 6 ñ ö ò ó Ø

p q r s 7 ß

t u v 8 ü ú û ü

w x y z 9

if you enter two letters in a row from the same button, press * between them or wait a few seconds
+ 0 @ * # & \$ £ / %

change between capital and lower case letters

delete the last letter or number entered. If you press the button for a long time, the entered number or text is deleted.



Calling from the memory

1. Press .
2. Choose from the following alternatives:
 - Press and scroll with the arrows until you find the desired name.
 - Press the key of the first letter in the name (or enter the name) and press .
3. Press to call the selected number.





Menu functions

The menu function is used to check and alter settings and programme new functions in your system. The different menus are shown in the display.

Menu function

Go into active mode. Press  to come to the menu function.

The following applies in the menu function:



- A long press on  means you exit the menu function.
- A short press on  means that you retract, cancel or reject an alternative.
- A press on  means that you confirm or select, or that you scroll from a submenu to the next submenu.
- The right arrow  leads to the next side menu. The left arrow  leads to the previous side menu.



Traffic safety

For reasons of safety, the menu system cannot be accessed at speeds in excess of 8 km/h (5 mph). You may only complete activities in the menu system that have already been started. The speed limiter can be disconnected using menu function 5.7.

Shortcuts

When you use the right arrow  to enter the menu system, you can use numbers instead of the arrows and the green button  to select the right menu on **the main menu level** (1, 2, 3, etc.), **first submenu level** (1.1, 2.1, 3.1, etc.) and the **second submenu level** (1.1.1, 2.1.1, etc.). The numbers are shown in the display together with the menu alternative.

Main menus/submenus

1. Call register

- 1.1 Missed calls
- 1.2 Received calls
- 1.3 Dialed calls
- 1.4 Erase list
 - 1.4.1 All
 - 1.4.2 Missed
 - 1.4.3 Received
 - 1.4.4 Dialed
- 1.5 Call duration
 - 1.5.1 Last call
 - 1.5.2 Number of calls
 - 1.5.3 Total time
 - 1.5.4 Clear

2. Messages

- 2.1 Read
- 2.2 Write
- 2.3 Voice message
- 2.4 Settings
 - 2.4.1 SMSC number
 - 2.4.2 Validity
 - 2.4.3 Type

3. Edit memory

- 3.1 Enter item
- 3.2 Search
 - 3.2.1 Edit
 - 3.2.2 Erase
 - 3.2.3 Copy
 - 3.2.4 Move
- 3.3 Copy all
 - 3.3.1 SIM to phone
 - 3.3.2 Phone to SIM
- 3.4 Speed dial
- 3.5 Empty SIM
- 3.6 Empty memory
- 3.7 Status

4. Call options

- 4.1 Transmit numbers
- 4.2 Call waiting
- 4.3 Automatic answer
- 4.4 Automatic dial
- 4.5 Speed dial
- 4.6 Call divert service
 - 4.6.1 All calls
 - 4.6.2 When busy
 - 4.6.3 When not answered
 - 4.6.4 If unreachable
 - 4.6.5 Fax calls
 - 4.6.6 Computer calls
 - 4.6.7 Cancel all diverts

5. Settings

- 5.1 Factory settings
- 5.2 Network selection
- 5.3 Language
 - 5.3.1 English UK
 - 5.3.2 English US
 - 5.3.3 Svenska
 - 5.3.4 Dansk
 - 5.3.5 Suomi
 - 5.3.6 Deutsch
 - 5.3.7 Nederlands
 - 5.3.8 Français FR
 - 5.3.9 Français CAN
 - 5.3.10 Italiano
 - 5.3.11 Español
 - 5.3.12 Português P
 - 5.3.13 Português BR
- 5.4 SIM security
 - 5.4.1 On
 - 5.4.2 Off
 - 5.4.3 AUTO
- 5.5 Change codes
 - 5.5.1 PIN code
 - 5.5.2 Telephone code
- 5.6 Volume
 - 5.6.1 Ringer volume
 - 5.6.2 Ringer tone
 - 5.6.3 Button click
 - 5.6.4 Speed volume
 - 5.6.5 Radio Auto Suppression
- 5.7 Traffic safety

Menu 1. Call register

1.1 Missed calls: A list of missed calls is shown here. You can choose to call, erase or store the number in the telephone or SIM card memory for later use.

1.2 Received calls: A list of received calls is shown here. You can choose to call, erase, or store the number in the telephone or SIM card memory for later use.

1.3 Dialed calls: A list of dialed numbers is shown here. You can choose to call, erase, or store the number in the telephone or SIM card memory for later use.

1.4 Erase list: This option can be used to erase the list of menus 1.1, 1.2 and 1.3 as follows.

- 1.4.1 All
- 1.4.2 Missed
- 1.4.3 Received
- 1.4.4 Dialed

1.5 Call duration: Here you can see the duration of all your calls or the most recent. You can also choose to see the number of calls and clear the call timer.

- 1.5.1 Last call
- 1.5.2 Number
- 1.5.3 Total time
- 1.5.4 Clear timer

The telephone code is needed to clear the call timer (see Menu 5.5).

Menu 2. Messages

2.1 Read: Here you can read received text messages. You can then choose to erase the last message, forward it, change or save the entire message or parts of it.

2.2 Write: Using the keypad, you can write a text message. Then choose to save or send it.

2.3 Voice message: Listen to received messages.

2.4 Settings: Enter the number (SMSC number) of the message centre you wish to have transfer your messages. Specify also how the message is to reach the addressee and how long it is to be stored in the message centre.

- 2.4.1 SMSC number
- 2.4.2 Validity
- 2.4.3 Type

Contact your service provider for information about these settings and the SMSC number.

Menu 3. Edit memory

3.1 Enter item: You can store names and telephone numbers in the telephone or SIM card memory. See the section on memory functions for more information.

3.2 Search: Changes in the memory can be made here.

- 3.2.1 Edit: Change data in the different memories.
- 3.2.2 Erase: Remove a saved name.
- 3.2.3 Copy: Copy a saved name.
- 3.2.4 Move: Transfer information between the memory of the telephone and the SIM card.

3.3 Copy all: Copy the telephone numbers and names on the SIM card to the telephone's memory.

- 3.3.1 From SIM to telephone memory
- 3.3.2 From Telephone to SIM memory

3.4 Speed dial: A number stored in the telephone book can be stored as a speed dial number.

3.5 Empty SIM: The entire memory of the SIM card can be erased.

3.6 Empty memory: The entire memory of the phone can be erased.

3.7 Status: See how many places in the SIM card or telephone memory are occupied by names and numbers.

Menu 4. Call options

4.1 Transmit number: Choose whether or not to display your number to the person you call. Contact your service provider for a permanently concealed number.

4.2 Call waiting: Choose whether or not you want to be alerted during a phone call that there is another call coming in.

4.3 Automatic answer: Chose to answer without using the keypad.

4.4 Automatic redial: Choose to call a previously dialled number that was busy.

4.5 Speed dial: Here you set whether or not speed dial is to be activated. In order to use speed dial, the function must be activated.

4.6 Call divert service: Here you can choose when and what type of calls are to be diverted to a specified telephone number.

- 4.6.1 All calls (this setting only applies during the current call).
- 4.6.2 When busy
- 4.6.3 When not answered
- 4.6.4 If unreachable
- 4.6.5 Fax calls
- 4.6.6 Computer calls
- 4.6.7 Cancel all diverts

Menu 5. Settings

5.1 Factory settings: Function to return to the system's factory settings.

5.2 Network selection: Choose a network automatically or manually.

- 5.2.1 Auto
- 5.2.2 Manual

5.3 Language: Here you can choose which language the telephone is to display.

- 5.3.1 English UK
- 5.3.2 English US
- 5.3.3 Svenska
- 5.3.4 Dansk
- 5.3.5 Suomi
- 5.3.6 Deutsch
- 5.3.7 Nederlands
- 5.3.8 Français FR
- 5.3.9 Français CAN
- 5.3.10 Italiano
- 5.3.11 Español
- 5.3.12 Português P
- 5.3.13 Português BR

5.4 SIM security: Choose if the PIN code is to be on, off, or automatic.

- 5.4.1 On
- 5.4.2 Off
- 5.4.3 Auto

5.5 Change codes: Change the PIN code or telephone code.

- 5.5.1 PIN code
- 5.5.2 Telephone code (use 1234 before you change to a personal code). The telephone code is used to clear the call timer.

NOTE! Make a note of the code and store it in a safe place.

5.6 Volume

- 5.6.1 Ringer volume: Here you can choose the volume of the ringer for incoming calls.
- 5.6.2 Ringer tone: There are eight different ringer tones to choose from.
- 5.6.3 Button click: On or off
- 5.6.4 Speed volume: Choose whether the volume should be adjusted according to speed.
- 5.6.5 Radio Auto Suppression: Here you choose whether the volume of the radio should remain the same during telephone calls.
- 5.6.6 New SMS: Choose whether you want the telephone to signal an incoming SMS or not.

5.7 Traffic safety: Here you can choose to disengage the speed limiter for the menu system, i.e. choose to use the menu system even while driving.

Miscellaneous information

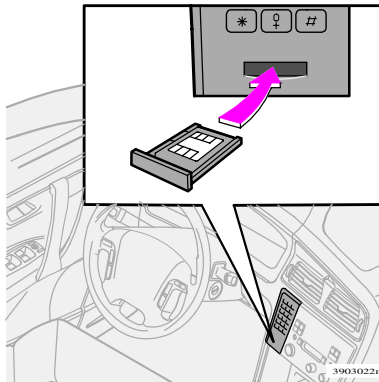

Specifications

Output	2W
SIM card	small
Memory positions	255*
SMS (Short Message Service)	Yes
Computer/Fax	No
Dual band	Yes (900/1800)

* 255 memory positions in the telephone memory. The number of memory positions on the SIM card varies depending on your subscription.

Radio - Telephone

The four lowest buttons in the steering wheel keypad are for both radio and telephone.

To use these buttons to control the telephone functions, the system must be activated, see page 162. If you wish to adjust the radio settings with these buttons, exit the telephone active mode. Press  .

Double SIM card

Many service providers offer double SIM cards, one for the car and a second one for another telephone. Double SIM cards give you the same number for two separate telephones. Ask your service provider about the possibilities and offers available regarding double SIM cards.

IMEI number

To block the telephone, inform the service provider of the telephone IMEI number. This is a 15 digit serial number programmed in the telephone. Dial *#06# to display this number. Write down the number and store it in a safe place.

Index

A

A/C	52
ABS	18, 27
Activating the alarm	73
Active chassis, FOUR-C	32, 87
Active mode	162
Actual temperature - ECC	45
Actual temperature	45
Advanced User Mode - radio	151
Air conditioning system	50
Air distribution	53
Air quality sensor	49
Air vents	46
Airbag - passenger side	13
Alarm	158
Anti-lock Brakes (ABS)	18
Audio system	141
AUM (Advanced User Mode) - radio	151
AUTO	50
Autodim	41
AUTO-DOWN	40
Automatic car washes	119
Automatic relocking	69
Automatic gearbox	83, 84
Automatic gearbox with manual positions (Geartronic)	85
AUTO-UP	40
Average fuel consumption	33

Average speed	33
AWD	86
Axle load	135

B

Backrest rake	58
Battery (jump starting)	90
Battery care	130, 131
Battery	55, 121, 130, 138
Beam length control	35
Bird droppings	118
Bonnet	124, 125
Booster battery	90
Booster cushion	22
Boot lid	70
Brake and clutch fluid	136
Brake fluid	129, 136
Brake system	18
Bulbs	138

C

Call options	163
Capacities	135
Car care	80
Cargo compartment	63
Cars with STC	28
Cassette deck	152
Catalytic converter	122
Catalytic exhaust treatment	122

CD changer	154, 155
CD player	153
Changing the oil and oil filter	127
Changing wheels	101
Child on board - location	24
Child seat and airbag	14
Child seat mounting (Isofix)	23
Cleaning seat belts	119
Cleaning upholstery	119
Coat hanger	66
Colour code	117
Combined instrument panel	26
Cooling system	135
Cruise control	34
Current fuel consumption	33

D

D Drive position	83, 85
Dashboard - left-hand drive	2
Dashboard - right-hand drive	3
Deactivating deadlocks	71
Deactivating the alarm	73
Deactivating the DSTC system	20
Deadlock	71
Defroster	50, 53
Detachable towbar - mounting the ball section	96
Detachable towbar - removing de ball section	97

Index

Diesel 37, 78, 126
Dipped beam 36
Direction indicators 36
Dolby Pro Logic Surround Sound 156
Door mirrors 41
Door mirror defroster 38
Double SIM cards 171
Downshift inhibitor 83
Drive position 83, 85
Driving characteristics and tyres 80
Driving with trailer 91, 92, 93
DSTC 20, 28

E

EBA (Emergency Brake Assistance) 20
ECC 48
Economical driving 82
Electric radiator fan 78, 124, 125
Electrical socket 39
Electrical system 138
Electronic Brakeforce Distribution
(EBD) 19
Electronic Climate Control ECC 48
Emergency calls 160
Emergency stop 60
Engine compartment 124, 125
Engine oil 127
Engine specifications 139, 140
Engine type designation 134

Environment class 139, 140
Environmental care 47
Exterior 6

F

Fan 52
Fault in SRS 29
FIX NEXT SERVICE 30
Floor carpets 81
Floor support 64
Fluid reservoir - brake/clutch 129
Folding the front passenger seat 59
Front end 137
Front fog lamps 35
Front seats 58
FOUR-C, Active chassis 32, 86
Fuel filler flap 78
Fuel filter - Diesel 126
Fuel tank 135
Function selector 50
Fuse box in passenger compartment .. 106
Fuses in cargo compartment 107
Fuses in engine compartment 105
Fuses 104

G

Gearbox type designation 134
Gear position, manual gearbox 82
Gear selector inhibitor 84, 86

Geartronic 85
General lighting 61
Generator not charging 29
Generator 138

H

Handbrake 39
Hazard warning flashers 38
Head restraints in rear seat 59
Headlamps and parking lamps 35
Heated front seats 38
Heating controls 50, 52
Heating/Cooling 52
Height setting - front seat 58
High-level brake light 115
HU-401 142
HU-601 143
HU-801 144

I

IC (Inflatable Curtain) 15
Ignition and steering wheel lock 37
Immediate heater start 55
Immobilizer 68, 79
Important tips! - Children in the car 21
Indicator and warning lamps ... 27, 29, 30
Instrument lighting 35
Interior - left-hand drive 4
Interior - right-hand drive 5

Index

- Interior lighting 61
Isofix bracket system for child seats 23
- J**
Jack 64, 102
Jumpstarting 90
- K**
Keylock 79
Keys 68
Kick-down 86
- L**
L Low gear position 83
Laminated side windows 43
Legroom adjustment 58
Lifting the car 121
Load carrier 81
Load curtain in cargo compartment 63
Location of children in the car 24
Locking and unlocking 69
Long loads 65
Low gear position 83
Lubricants 136
Lumbar support 58
- M**
Main beam “flash” 36
Main/dipped beam switch 36
Manual child safety locks 72
- Manual climate control with air
conditioning A/C 52
Manual climate control with air
conditioning 52
Manual gearbox 82
Master key 68
Max. total weight 135
Max. trailer weight 135
Misting on window interiors 45
Mounting bracket 64
Multifilter 47
- N**
N Neutral position 83, 85
Negative cable 131
- O**
Octane rating 139, 140
Oil grade 127
Oil pressure 29
Open boot lid 80
Opening fuel filler flap 78
Orange symbol 28
Oxyhydrogen 131
- P**
P Park 83, 85
Paintwork 117
Paintwork damage 117
Parking Assistance System 88
- Parking brake applied 29
Parking brake 39
Parking heater 54
Parking/Position light 35
Polishing and waxing 119
Pollen filter 47
Position/Parking light 35
Positive cable 131
Power output 139, 141
Power seat 60
Power steering 129, 135
Power sunroof 42
Power transmission 137
Power windows 40
Pregnant women 21
- R**
R Reverse 83, 85
Radio mode 37
Radio 141
Rain sensor 37
Raising the booster cushion 22
Range to empty fuel tank 33
Reading lamps, front and rear 61
Rear fog lamp 35
Rear suspension 137
Rear window defroster 38
Rearview mirror 41
Recirculation 51, 52
Red symbol 28

Index

Refuelling	78	Shift lock	79	Sun blind	43
Relay/fuse box in cargo compartment	104	SIM card	160	Sun shade	42
Relay/fuse box in engine compartment	104	SIPS - left-hand drive	11	Sunroof	42
Remote control	60	SIPS - right-hand drive	11	Switches in the centre console	31, 32
Replacing bulbs in the rear lamp cluster	110	SIPS		Symbols	130
Replacing bulbs	108	(Side Impact Protection System)	9, 11	T	
Replacing dipped beam and main beam bulb	108	Ski hatch	65	Telephone system	160
Replacing headlamp wiper	132	Slippery road surface	79	Temperature	50
Replacing parking lamp bulb	109	Snow chains	98	Temporary spare	100
Replacing the battery - remote control	70	Some important tips!	81	TIMER I	54
Replacing the battery	131	Socket for cigarette lighter	40	TIMER II	54
Reverse gear detent	82	Spare wheel	64, 102	Tipping the backrest forward	65
RFD (Road Friction Detection)	20	Spark plugs	139, 140	Toolkit with towing eye	64
Rheostat for instrument lighting	33	Special rims	98	Tools	64
Roof load	135	Speed-related power steering	80	Torque	139, 140
Rustproofing	116	SRS	10	Towbar	90
S		SRS (airbag)	9	Towing bracket	91
Seat belts	8	Start position	37	Towing eye	89
Select the right gear	80	Starter motor	138	Towing	89
Service key	68	Starting the engine	78	Traffic information	149
Service reminder	30	STC	19, 28	Traffic safety	167
SERVICE REQUIRED	30	Steering wheel adjustment	36	Trailer	92
Shift lock - Geartronic	86	Stone chips and scratches	117	Train weight	135
		STOP SAFELY ASAP	30	Transmission oil	135
		Storage compartments in centre console	63	Trip computer	33
		Storage compartments	62	Type designation	134
		Studded tyres	98	Tyre pressure	99
		Suitable detergent	118	Tyres	98

Index

U	
Unlocking the boot lid with the master key	70
V	
Vanity mirror	61
Ventilation	46
VIN (Vehicle identification number) ...	134
Volume control	145
Volvo integrated booster cushion	22
Volvo service programme	122
W	
W - Winter	84, 86
Warning - fault in ABS system	27
Warning - fault in brake system	27
Warning - risk of traction loss	28
Warning triangle	64, 101
Washer fluid reservoir	129
Washer fluid	129
Washing	118
Wear indicators	100
Weights and measurements	135
Wheels	98
When it is dark	71
WHIPS	16
Windscreen washer reservoir	135
Windscreen wipers	37
Windscreen/headlamp washers	37
Winter tyres	98
Wiper blades, replacing	132
Y	
Your climate control system - useful hints	47

The following should be regularly checked:

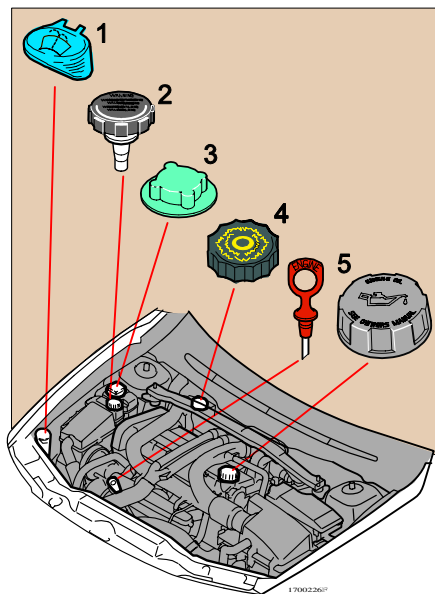

1. Washer fluid: Ensure that the reservoir is always well filled. In the winter use a washer fluid with anti freeze! See page 129.

2. Power steering: The level should lie between the MIN- and MAX marks. See page 129.

3. Engine coolant: The level should lie between the MIN- and MAX marks on the expansion tank. See page 128.

4. Brake fluid level: The level should lie between the MIN- and MAX marks. See page 129.

5. Oil level: The level should lie between the marks on the dipstick. See page 128.

Tyre pressures

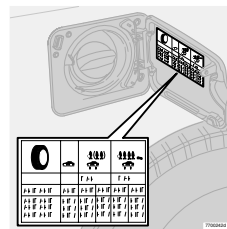

Bulbs

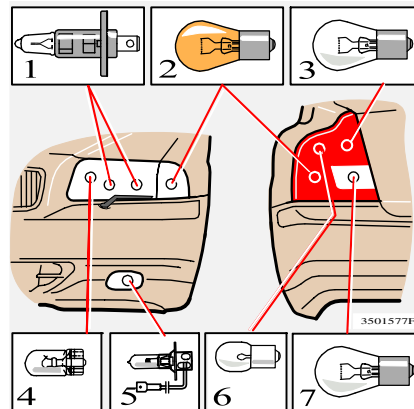

- | | | |
|----|--------|------------|
| 1. | 55 W | H 7 |
| 2. | 21 W | PY |
| 3. | 21/4 W | BAY 15d |
| 4. | 5 W | W2,1x9, 5d |
| 5. | 55 W | H 1 |
| 6. | 5 W | BA 15 |
| 7. | 21 W | BAY 15 |

VOLVO

Volvo Car Corporation
S-40531 Gothenburg, Sweden