

Alto

OWNER'S MANUAL

**Keep With Vehicle At All Times.
Contains Important Information
On Safety, Operation & Maintenance.**



Way of Life!

This owner's manual applies to the ALTO series.

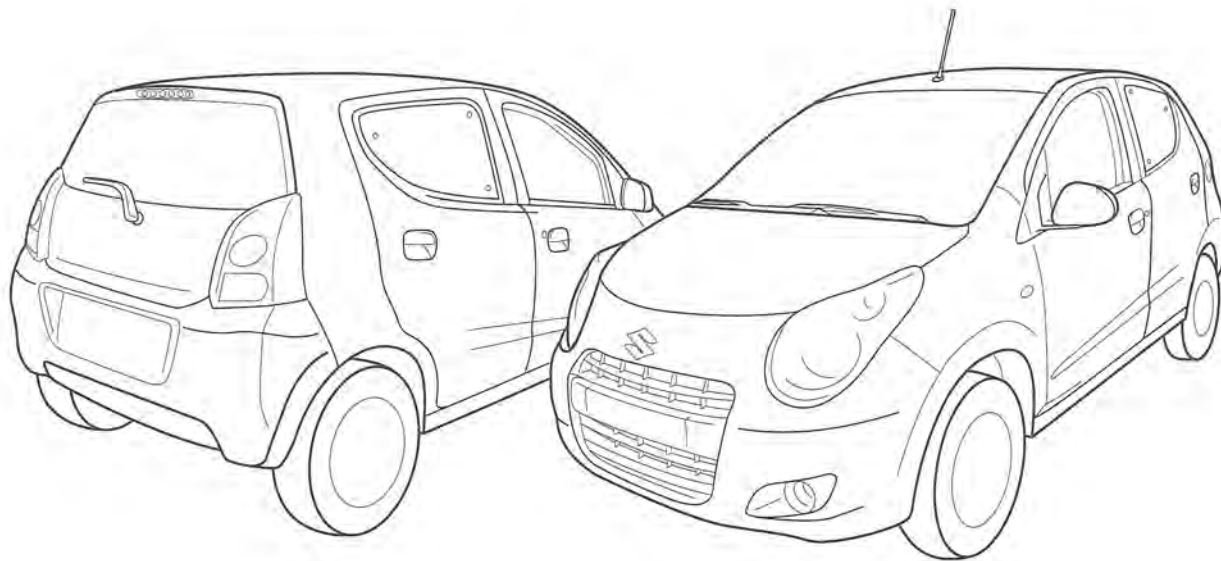

68KM001

NOTE: The illustrated models are examples of the ALTO series.

© 2010 **SUZUKI MOTOR CORPORATION** All rights reserved.

No part of this document may be reproduced or transmitted in any form or by any means, electronic or mechanical, for any purpose, without the express written permission of Suzuki Motor Corporation.

FOREWORD

This manual should be considered a permanent part of the vehicle and should remain with the vehicle when resold or otherwise transferred to a new owner or operator. Please read this manual carefully before operating your new SUZUKI and review the manual from time to time. It contains important information on safety, operation and maintenance.

SUZUKI MOTOR CORPORATION

All information in this manual is based on the latest product information available at the time of publication. Due to improvements or other changes, there may be discrepancies between information in this manual and your vehicle. SUZUKI MOTOR CORPORATION reserves the right to make production changes at any time, without notice and without incurring any obligation to make the same or similar changes to vehicles previously built or sold.

This vehicle may not comply with standards or regulations of other countries. Before attempting to register this vehicle in any other country, check all applicable regulations and make any necessary modifications.

IMPORTANT

▲ WARNING/CAUTION/NOTE

Please read this manual and follow its instructions carefully. To emphasize special information, the symbol ▲ and the words **WARNING**, **CAUTION** and **NOTE** have special meanings. These special meanings apply except when laws or regulations require that the signal words be used with a different meaning. Pay special attention to the messages highlighted by these signal words:

▲ WARNING

Indicates a potential hazard that could result in death or injury.

CAUTION

Indicates a potential hazard that could result in vehicle damage.

NOTE:

Indicates special information to make maintenance easier or instructions clearer.

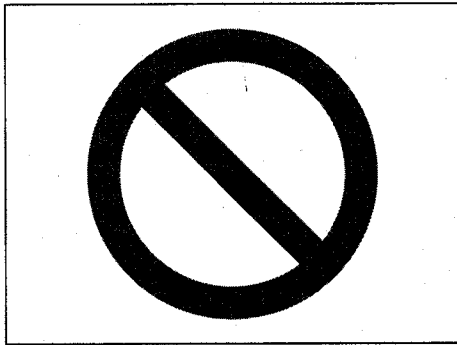

75F135

The circle with a slash in this manual means "Don't do this" or "Don't let this happen".

MODIFICATION WARNING

WARNING

Do not modify this vehicle. Modification could adversely affect safety, handling, performance, or durability and may violate governmental regulations. In addition, damage or performance problems resulting from modification may not be covered under warranty.

CAUTION

Improper installation of mobile communication equipment such as cellular telephones or CB (Citizen's Band) radios may cause electronic interference with your vehicle's ignition system, resulting in vehicle performance problems. Consult your SUZUKI dealer or qualified service technician for advice on installing such mobile communication equipment.

INTRODUCTION

Thank you for choosing SUZUKI and welcome to our growing family. Your choice was a wise one; SUZUKI products are a great value that will give you years of driving pleasure.

This Owner's Manual was prepared to help you have a safe, enjoyable, and trouble-free experience with your SUZUKI. In it you will learn about the vehicle's operation, its safety features and maintenance requirements. Please read it carefully before operating your vehicle. Afterwards, keep this Manual in the glove box for future reference.

Should you resell the vehicle, please leave this Manual with it for the next owner.

In addition to the Owner's Manual, the other booklets provided with your SUZUKI explain the vehicle's warranties. We recommend you read them as well to familiarize yourself with this important information.

When planning the regular scheduled maintenance of your SUZUKI, we recommend you visit your local SUZUKI dealership. Their factory-trained technicians will provide the best possible service and use only genuine SUZUKI parts and accessories.

NOTE:

"SUZUKI dealer" means Authorised Suzuki Service Workshop (in Europe).

RECOMMENDATION OF GENUINE SUZUKI PARTS AND ACCESSORIES USE

SUZUKI strongly recommends the use of genuine SUZUKI parts* and accessories. Genuine SUZUKI parts and accessories are built to the highest standards of quality and performance, and are designed to fit your vehicle's exact specifications.

A wide variety of non-genuine replacement parts and accessories for SUZUKI vehicles are currently available in the market. Using these parts and accessories can affect the vehicle performance and shorten its useful life. Therefore, installation of non-genuine SUZUKI parts and accessories is not covered under warranty.

Non-Genuine SUZUKI Parts and Accessories

Some parts and accessories may be approved by certain authorities in your country.

Some parts and accessories are sold as SUZUKI-authorized replacement parts and accessories. Some genuine SUZUKI parts and accessories are sold as re-use parts and accessories. These parts and accessories are non-genuine SUZUKI parts and accessories and use of these parts is not covered under warranty.

Re-use of Genuine SUZUKI Parts and Accessories

The resale or re-use of the following items which could give rise to safety hazards for users is expressly forbidden:

- Air bag components and all other pyrotechnic items, including their components (e.g. cushion, control devices and sensors)
- Seat belt system, including their components (e.g. webbing, buckles, and retractors)

The air bag and seat belt pretensioner components contain explosive chemicals. These components should be removed and disposed of properly by SUZUKI-authorized service shop or scrap yard to avoid unintended explosion before scrapping.

*The parts remanufactured under SUZUKI's approval can be used as genuine SUZUKI parts in Europe.

SERVICE STATION GUIDE

1. Fuel (see section 1)
2. Engine hood (see section 5)
3. Tire changing tools (see section 8)
4. Engine oil dipstick <Yellow> (see section 7)
5. Automatic transaxle fluid dipstick <Red> (see section 7)
6. Engine coolant (see section 7)
7. Windshield washer fluid (see section 7)
8. Battery (see section 7)
9. Tire pressure (see Tire Information Label on driver's door lock pillar)
10. Spare tire (see section 7)
11. Flat tire repair kit (see Section 8)

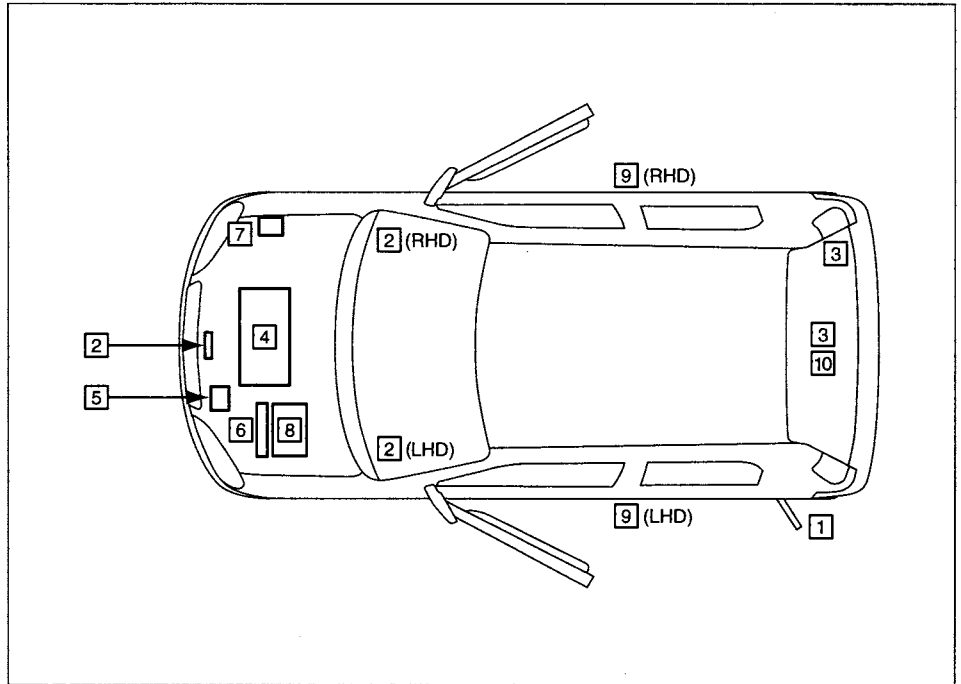

LHD: Left Hand Drive
RHD: Right Hand Drive

MEMO

A series of horizontal dashed lines for writing.

TABLE OF CONTENTS

FUEL RECOMMENDATION	1
BEFORE DRIVING	2
OPERATING YOUR VEHICLE	3
DRIVING TIPS	4
OTHER CONTROLS AND EQUIPMENT	5
VEHICLE LOADING AND TOWING	6
INSPECTION AND MAINTENANCE	7
EMERGENCY SERVICE	8
APPEARANCE CARE	9
GENERAL INFORMATION	10
SPECIFICATIONS	11
SUPPLEMENT	12
INDEX	13

ILLUSTRATED TABLE OF CONTENTS

EXTERIOR

1. Rear window wiper (P. 2-54)
2. Engine hood (P. 5-31)
3. Windshield wiper (P. 2-52)
4. Radio antenna (P. 5-8)
5. Outside rearview mirror (P. 2-9)
6. Fuel filler cap (P. 5-30)
7. Tailgate (P. 2-4)
8. Child-proof locks (rear door) (P. 2-3)
9. Tires (P. 7-19)
10. Door locks (P. 2-2), Keys (P. 2-1)

EXAMPLE

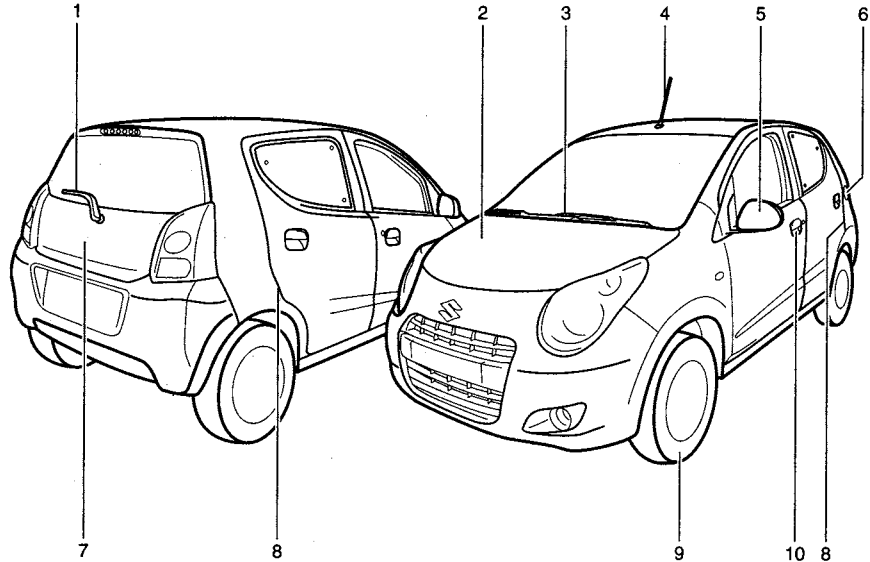

INTERIOR

1. Seat belts (P. 2-13)
2. Curtain air bags (if equipped) (P. 2-34)
3. Electric window controls (P. 2-7)
4. Sun visor (P. 5-32)
5. Interior light (P. 5-32)
6. Inside rearview mirror (P. 2-8)
7. Luggage area cover (if equipped) (P. 5-34)
8. Rear seats (P. 2-11)
9. Side air bags (if equipped) (P. 2-34)
10. Parking brake lever (P. 3-5)
11. Front seats (P. 2-10)
12. Gearshift lever (P. 3-8)

EXAMPLE

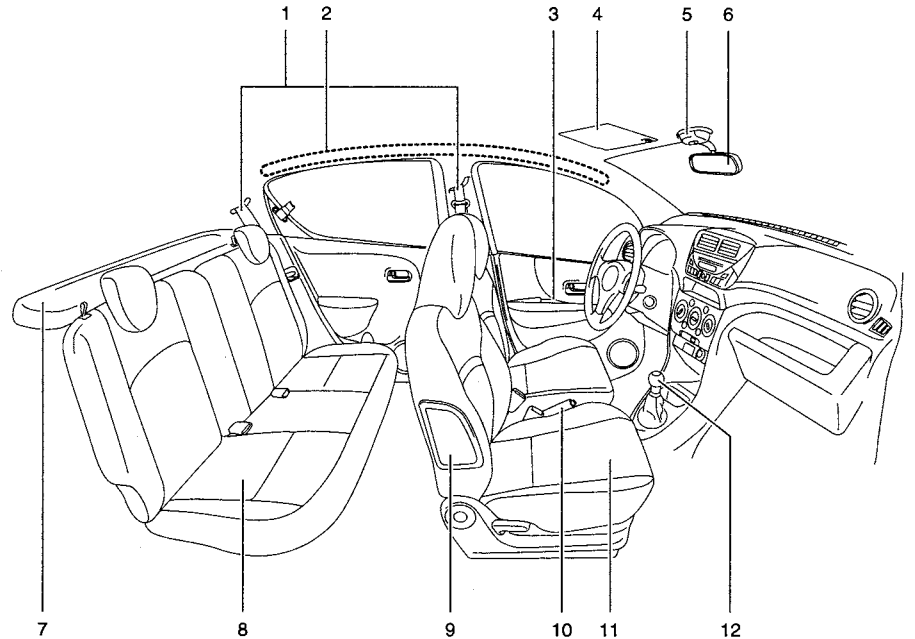

ILLUSTRATED TABLE OF CONTENTS

INSTRUMENT PANEL

1. Lighting control lever (P. 2-48)/
Turn signal control lever (P. 2-51)
2. Tachometer (if equipped) (P. 2-45)
3. Instrument cluster (P. 2-38)
4. Odometer (P. 2-47)/
Tripmeter (P. 2-47)/Clock (P. 2-47)
5. Windshield wiper and washer switch
(P. 2-52)/Rear window wiper and
washer switch (P. 2-54)
6. Audio (if equipped) (P. 5-9)
7. Air bag (P. 2-31)
8. Fuse box (P. 7-24)
9. Hood release (P. 5-31)
10. Headlight leveling switch (if equipped)
(P. 2-50)
11. Front fog light switch (if equipped)
(P. 2-50)
12. "TCSS OFF" switch (if equipped)
(P. 3-16)
13. Ignition switch (P. 3-3)
14. Hazard warning switch (P. 2-52)
15. Accessory socket (P. 5-33)
16. Heating and air conditioning system
(if equipped) (P. 5-1)
17. Glove box (P. 5-33)

EXAMPLE

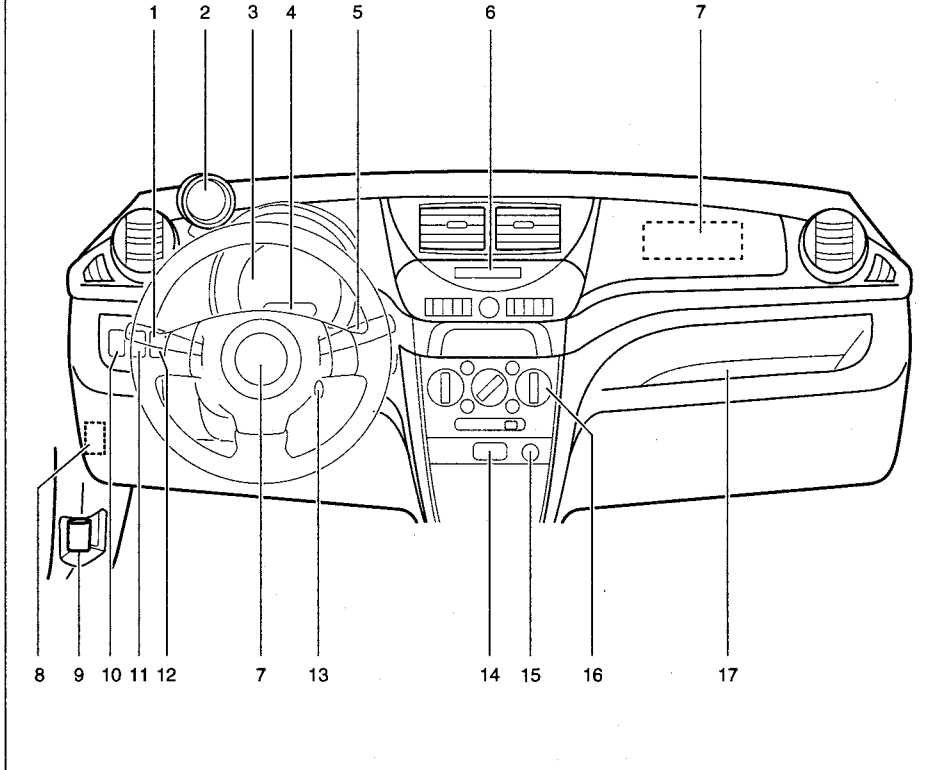

FUEL RECOMMENDATION

Fuel Recommendation 1-1

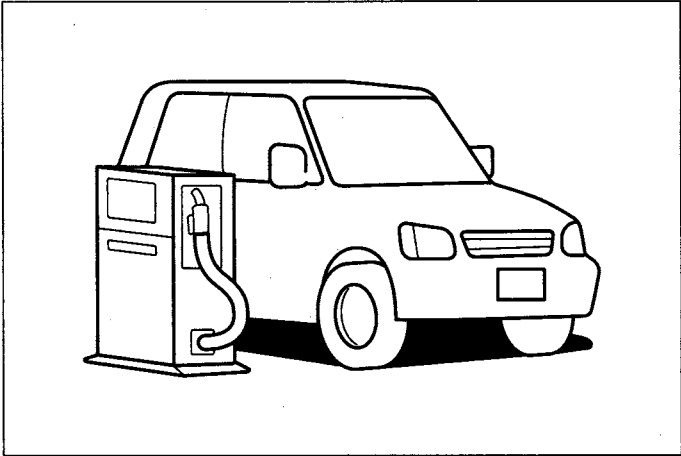

65D394

FUEL RECOMMENDATION

Fuel Recommendation

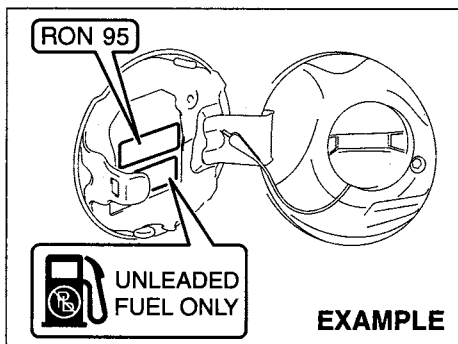

If your vehicle is not fitted with a restrictor in the fuel filler pipe then you may use leaded or unleaded gasoline with an octane number (RON) of 85 or higher. Note, it is preferable to use unleaded gasoline.

If your vehicle is fitted with a restrictor in the fuel filler pipe then you **must** use unleaded gasoline with an octane number (RON) of 91 or higher (or RON of 95 or higher if it is stated on the fuel filler lid). These vehicles are also identified by a label attached near the fuel filler pipe that states: "UNLEADED FUEL ONLY", "NUR UNVERBLEITES BENZIN", "ENDAST BLYFRI BENSIN" or "SOLO GASOLINA SIN PLOMO".

If the "RON 95" label is attached, you must use unleaded gasoline with an octane number (RON) of 95 or higher.

Gasoline/Ethanol blends

Blends of unleaded gasoline and ethanol (grain alcohol), also known as gasohol, are commercially available in some areas. Blends of this type may be used in your vehicle if they are no more than 10% ethanol. Make sure this gasoline-ethanol blend has octane ratings no lower than those recommended for gasoline.

Gasoline/Methanol blends

Blends of unleaded gasoline and methanol (wood alcohol) are also commercially available in some areas. DO NOT USE fuels containing more than 5% methanol under any circumstances. Fuel system damage or vehicle performance problems resulting from the use of such fuels are not the responsibility of SUZUKI and may not be covered under the New Vehicle Warranty. Fuels containing 5% or less methanol may be suitable for use in your vehicle if they contain cosolvents and corrosion inhibitors.

NOTE:

If you are not satisfied with the driveability or fuel economy of your vehicle when you are using a gasoline/alcohol blend, you should switch back to unleaded gasoline containing no alcohol.

CAUTION

The fuel tank has an air space to allow for fuel expansion in hot weather. If you continue to add fuel after the filler nozzle has automatically shut off or an initial blowback occurs, the air chamber will become full. Exposure to heat when fully fuelled in this manner will result in leakage due to fuel expansion. To prevent such fuel leakage, stop filling after the filler nozzle has automatically shut off, or when using an alternative non-automatic system, initial vent blowback occurs.

CAUTION

Be careful not to spill fuel containing alcohol while refueling. If fuel is spilled on the vehicle body, wipe it up immediately. Fuels containing alcohol can cause paint damage, which is not covered under the New Vehicle Limited Warranty.

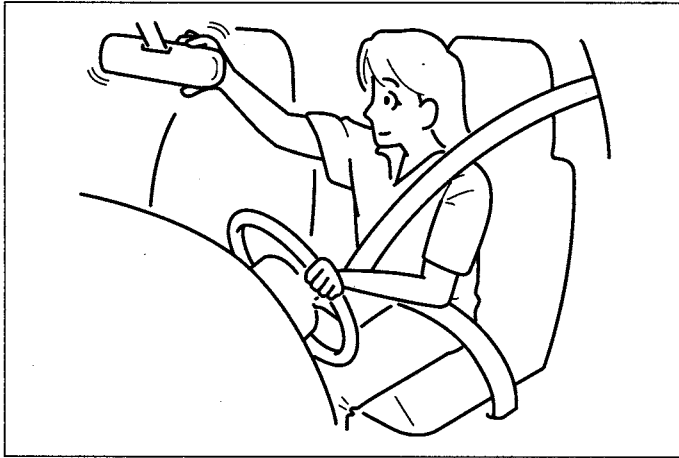

60G404

BEFORE DRIVING

Keys	2-1
Door Locks	2-2
Keyless Entry System Transmitter (if equipped)	2-4
Windows	2-7
Mirrors	2-8
Front Seats	2-9
Rear Seats	2-10
Seat Belts and Child Restraint Systems	2-12
Child Restraint System for EU Countries	2-20
Supplemental Restraint System (air bags) (if equipped)	2-30
Instrument Cluster	2-37
Warning and Indicator Lights	2-38
Transaxle Selector Position Indicator (if equipped)	2-44
Speedometer	2-44
Tachometer (if equipped)	2-44
Fuel Gauge	2-45
Information Display	2-45
Lighting Control Lever	2-47
Front Fog Light Switch (if equipped)	2-49
Rear Fog Light Switch (if equipped)	2-49
Headlight Leveling Switch (if equipped)	2-49
Turn Signal Control Lever	2-50
Hazard Warning Switch	2-51
Windshield Wiper and Washer Lever	2-51
Tilt Steering Lock Lever (if equipped)	2-53
Horn	2-54
Heated Rear Window Switch (if equipped)	2-54

Keys

EXAMPLE

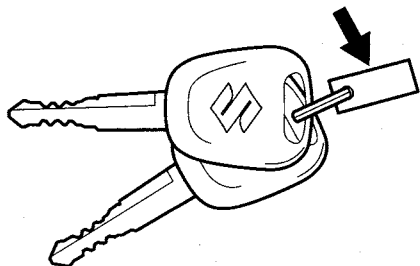

51KM024

Your vehicle comes with a pair of identical keys. Keep the spare key in a safe place. One key can open all of the locks on the vehicle.

The key identification number is stamped on a metal tag provided with the keys or on the keys. Keep the tag (if equipped) in a safe place. If you lose your keys, you will need this number to have new keys made. Write the number below for your future reference.

KEY NUMBER:

Immobilizer System (if equipped)

This system is designed to help prevent vehicle theft by electronically disabling the engine starting system.

The engine can be started only with your vehicle's original immobilizer ignition key which has an electronic identification code programmed into it. The key communicates the identification code to the vehicle when the key is turned to the "ON" position. If you need to make spare keys, see your SUZUKI dealer. The vehicle must be programmed with the correct identification code for the spare keys. A key made by an ordinary locksmith will not work.

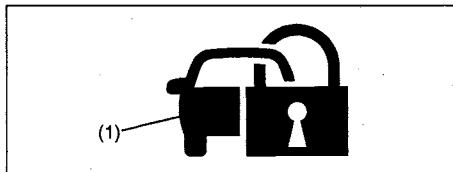

54G003

If the immobilizer system light (1) blinks when the ignition switch is in the "ON" position, there may be something wrong with your key or with the immobilizer system. Ask your SUZUKI dealer to inspect the system.

NOTE:

- If you lose your immobilizer ignition key, see your SUZUKI dealer as soon as possible to have the lost one deactivated, then have the new key made by them.
- If you own other vehicles with immobilizer keys, keep those keys away from the ignition switch when using your SUZUKI, or the engine may not be started because they may interfere with your SUZUKI's immobilizer system.
- If you attach any metal objects to the immobilizer key, it may not start the engine.

CAUTION

The immobilizer key is a sensitive electronic instrument. To avoid damaging the immobilizer key:

- Do not expose it to impacts, moisture or high temperature such as on the dashboard under direct sunlight.
- Keep the immobilizer key away from magnetic objects.

This immobilizer system, model 5WK49846/5WK49997 is in compliance with the essential requirements and other provisions of the Directive 1999/5/EC.

Ignition Key Reminder (if equipped)

A buzzer sounds intermittently to remind you to remove the ignition key if it is in the ignition switch when the driver's door is opened.

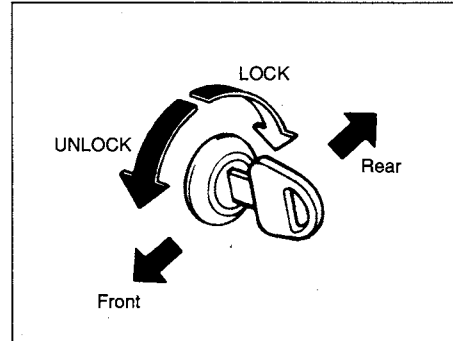
Door Locks**Side Door Locks****Driver's door**

60B008

To lock a driver's door from outside the vehicle:

- Insert the key and turn the top of the key toward the rear of the vehicle, or
- Turn the lock knob forward, then pull and hold the door handle as you close the door.

To unlock a driver's door from outside the vehicle, insert the key and turn the top of the key toward the front of the vehicle.

To lock a front passenger's door from outside the vehicle, turn the lock knob forward, then pull and hold the door handle as you close the door.

To lock a rear door from outside the vehicle, turn the lock knob forward and close the door.

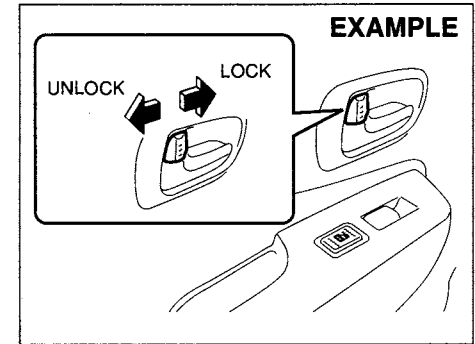

68KM006

To lock a door from inside the vehicle, turn the lock knob forward. Turn the lock knob backward to unlock the door. You do not need to pull and hold the door handle as you close the door.

BEFORE DRIVING

Central Door Locking System

Driver's door

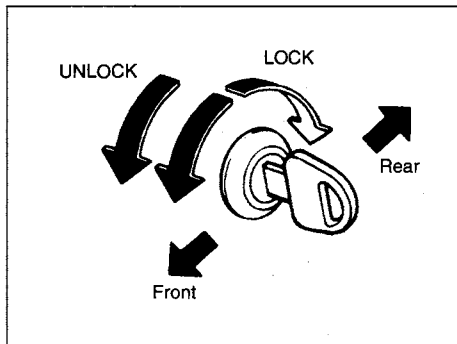

54G294

You can lock and unlock all doors simultaneously by using the key in the driver's door lock.

To lock all doors simultaneously, insert the key in the driver's door lock and turn the top of the key toward the rear of the vehicle once.

To unlock all doors simultaneously, insert the key in a driver's door lock and turn the top of the key toward the front of the vehicle twice.

To unlock the driver's door only, insert the key in that door lock and turn the top of the key toward the front of the vehicle once.

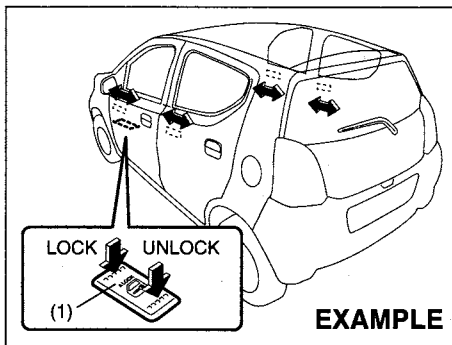

68KM007

You can also lock or unlock all doors by depressing the front or rear of the switch (1), respectively.

NOTE:

If your vehicle is equipped with keyless entry system, you can also lock or unlock all doors by operating the transmitter. Refer to "Keyless Entry System Transmitter".

Child-Proof Locks (rear door)

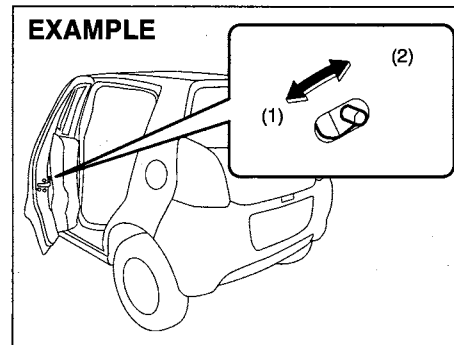

68KH020

- (1) LOCK
- (2) UNLOCK

Each of the rear doors is equipped with a child-proof lock which can be used to help prevent unwanted opening of the door from inside the vehicle. When the lock lever is in the "LOCK" position (1), the rear door can only be opened from outside. When the lock lever is in the "UNLOCK" position (2), the rear door can be opened from inside or outside.

WARNING

Be sure to place the child-proof lock in the "LOCK" position whenever children are seated in the rear.

Tailgate

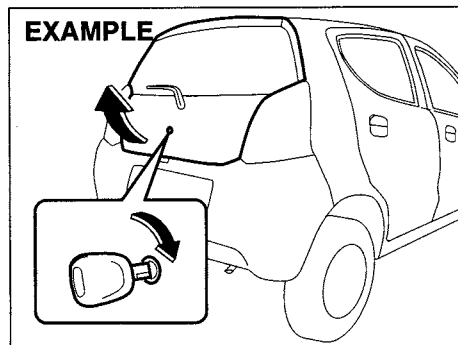

68KM008

To open the tailgate, insert the key and turn it clockwise to unlatch and lift the tailgate.

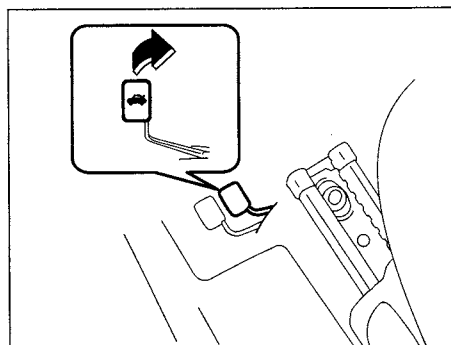

68KM009

If the release lever is equipped on the outboard side of the driver's seat, you can also unlatch the tailgate by pulling it.

⚠ WARNING

Always make sure that the tailgate is closed and latched securely. Completely closing the tailgate helps prevent occupants from being thrown from the vehicle in the event of an accident. Completely closing it also helps keep exhaust gases from entering the car.

CAUTION

Do not use the key to lift up the lid, or the key may break off in the lock.

Keyless Entry System Transmitter (if equipped)

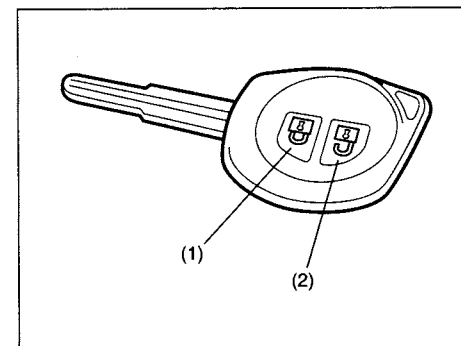

81A184

- (1) "LOCK" button
(2) "UNLOCK" button

You can lock or unlock all doors simultaneously by operating the transmitter near the vehicle.

- To lock all doors, push the "LOCK" button (1) once.
- To unlock only the driver's door, push the "UNLOCK" button (2) once.
- To unlock other doors, push the "UNLOCK" button (2) once again.

BEFORE DRIVING

The turn signal lights will flash once when the doors are locked.

When the doors are unlocked:

- The turn signal lights will flash twice.
- If the interior light switch is in the middle position, the interior light will turn on for about 15 seconds and then fade out. If you insert the key into the ignition switch during this time, the light will start to fade out immediately.

Be sure the doors are locked after you operate the "LOCK" button. If no door is opened within about 30 seconds after the "UNLOCK" button is operated, the doors will automatically lock again.

NOTE:

- *The maximum operating distance of the keyless entry system transmitter is about 5 m (16 ft.), but this can vary depending on the surroundings, especially near other transmitting devices such as radio towers or CB (Citizen's Band) radios.*
- *The door locks cannot be operated with the transmitter if the ignition key is inserted in the ignition switch.*
- *When any door is open, the door locks can be operated only unlock with the transmitter.*

- *If you lose one of the transmitters, ask your SUZUKI dealer as soon as possible for a replacement. Be sure to have your dealer program the new transmitter code in your vehicle's memory so that the old code is erased.*

CAUTION

The transmitter is a sensitive electronic instrument. To avoid damaging the transmitter:

- **Do not expose it to impacts, moisture or high temperature such as by leaving it on the dashboard under direct sunlight.**
- **Keep the transmitter away from magnetic objects such as a television.**

Replacement of the Battery

If the transmitter becomes unreliable, replace the battery.

To replace the battery of the transmitter:

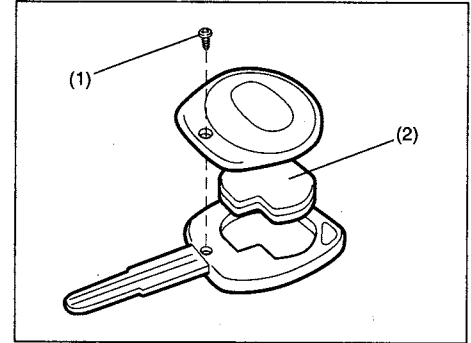

81A185

- 1) Remove the screw (1), and open the transmitter cover.
- 2) Remove the transmitter (2).

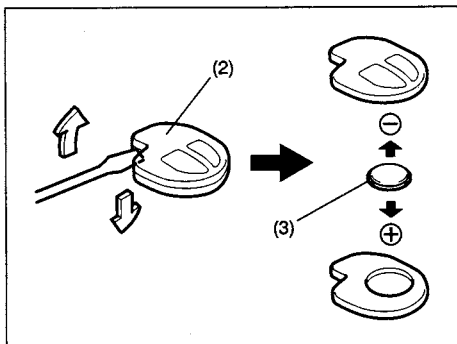

80JM135

- 3) Put the edge of a flat blade screw driver in the slot of the transmitter (2) and pry it open.
- 4) Replace the battery (3) (Lithium disc-type CR1616 or equivalent) so its + terminal faces the "+" mark of the transmitter.
- 5) Close the transmitter and install it into the transmitter holder.
- 6) Close the transmitter cover, install and tighten the screw (1).
- 7) Make sure the door locks can be operated with the transmitter.
- 8) Dispose of the used battery properly according to applicable rules or regulations. Do not dispose of lithium batteries with ordinary household trash.

NOTE:
Used batteries must be disposed properly according to applicable rules or regulations and must not be disposed with ordinary household trash.

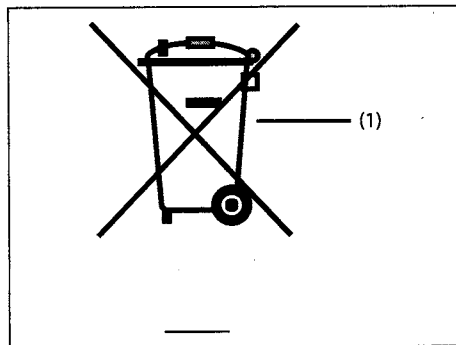

80JM133

(1) Crossed-out wheeled bin symbol

The crossed-out wheeled bin symbol (1) indicates that used battery should be collected separately from ordinary household trash.

By ensuring the used battery is disposed or recycled correctly, you will help prevent potential negative consequences for the environment and human health, which could otherwise be caused by inappropriate trash handling of the battery. The recycling of materials will help to conserve

natural resources. For more detailed information about disposing or recycling of the used battery, consult your SUZUKI dealer.

BEFORE DRIVING

Windows

Manual Window Control (if equipped)

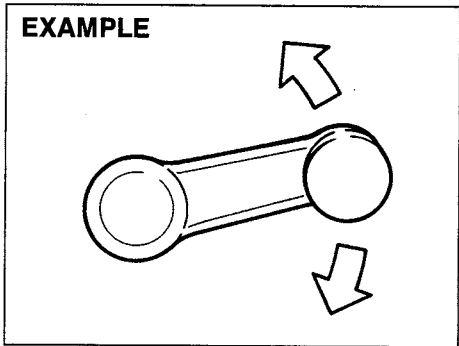

60G010

Raise or lower the door windows by turning the handle located on the door panel.

Electric Window Controls (if equipped)

The electric windows can only be operated when the ignition switch is in the "ON" position.

Driver's door

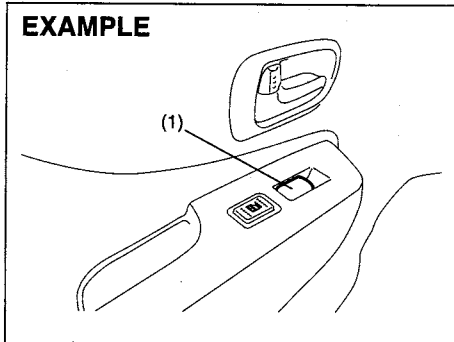

68KM010

The driver's door has a switch (1) to operate the driver's window.

Passenger's door

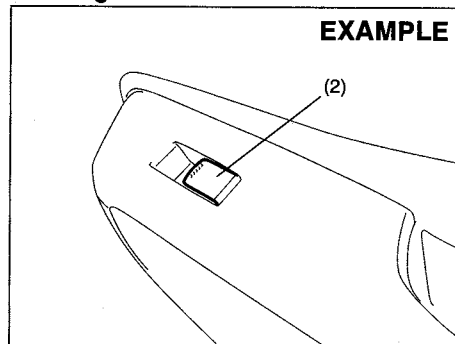

68KM011

The passenger's door has a switch (2) to operate that passenger's window.

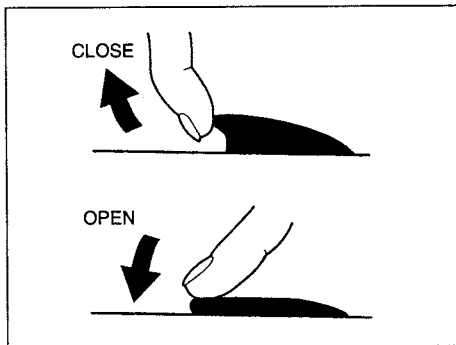

81A009

To open a window, push the top part of the switch and to close the window, lift up the top part of the switch.

⚠ WARNING

- To avoid injuring an occupant by window entrapment, be sure no part of the occupant's body such as hands or head is in the path of the electric windows when closing them.
- Always remove the ignition key when leaving the vehicle even if only for a short time. Also do not leave children alone in a parked vehicle. Unattended children could use the electric window switches and get trapped by the window.

Pop-up Window

EXAMPLE

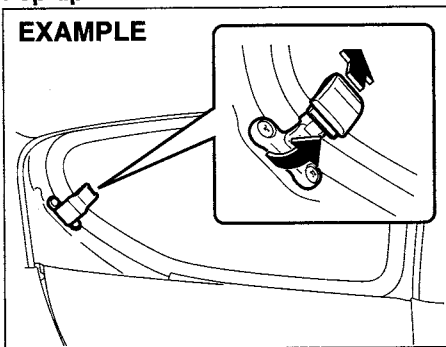

68KM012

To open the rear side pop-up window, pull up the handle of the window and push it to outside.

Mirrors

Inside Rearview Mirror

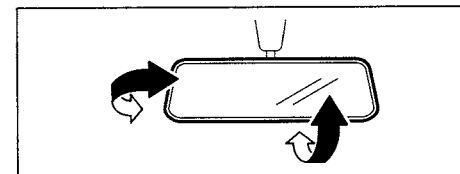

68KH007

You can adjust the inside rearview mirror by hand so as to see the rear of your vehicle in the mirror.

BEFORE DRIVING

Outside Rearview Mirrors

Adjust the outside rearview mirrors so you can just see the side of your vehicle in the mirrors.

⚠ WARNING

Be careful when judging the size or distance of a vehicle or other object seen in the side convex mirror. Be aware that objects look smaller and appear farther away than when seen in a flat mirror.

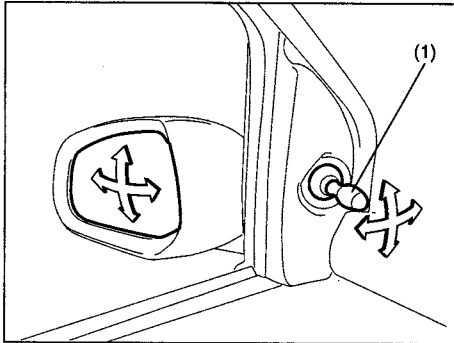

68KM014

You can adjust the outside rearview mirrors by hand with the knob (1) located on the driver's or front passenger's door panel.

Front Seats

Seat Adjustment

⚠ WARNING

Never attempt to adjust the driver's seat or seatback while driving. The seat or seatback could move unexpectedly, causing loss of control. Make sure that the driver's seat and seatback are properly adjusted before you start driving.

⚠ WARNING

To avoid excessive seat belt slack, which reduces the effectiveness of the seat belts as a safety device, make sure that the seats are adjusted before the seat belts are fastened.

Adjusting Seat Position

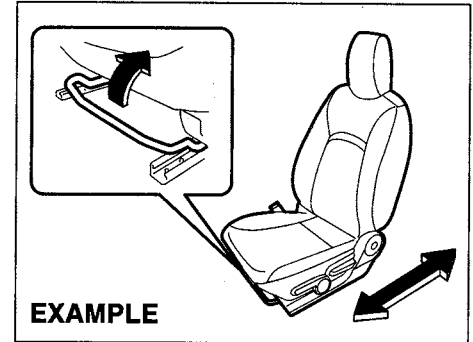

68KM015

The adjustment lever for each front seat is located under the front of the seat. To adjust the seat position, pull up on the adjustment lever and slide the seat forward or rearward.

After adjustment, try to move the seat forward and rearward to ensure that it is securely latched.

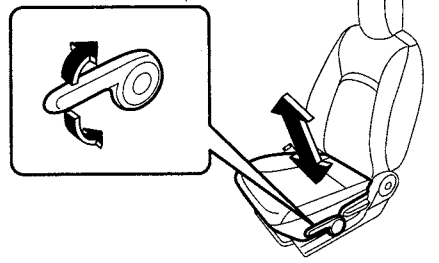
EXAMPLE

68KM016

If the driver's seat is equipped with a seat height adjuster lever on the outboard side of the seat, raise or lower the seat by pulling up or down the adjuster lever.

Adjusting Seatbacks**⚠ WARNING**

All seatbacks should always be in an upright position when driving, or seat belt effectiveness may be reduced. Seat belts are designed to offer maximum protection when seatbacks are in the upright position.

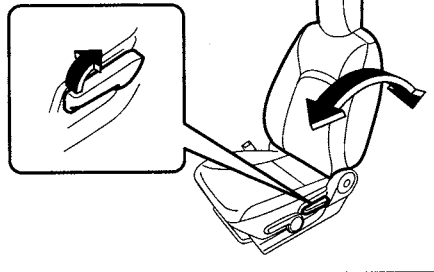
EXAMPLE

68KM017

To adjust the seatback angle of front seats, pull up the lever on the outboard side of the seat, move the seatback to the desired position, and release the lever to lock the seatback in place.

Rear Seats**Head Restraints (if equipped)**

Head restraints are designed to help reduce the risk of neck injuries in the case of an accident.

⚠ WARNING

- Never drive the vehicle with the head restraints removed.
- Do not attempt to adjust the head restraint while driving.

NOTE:

It may be necessary to fold forward the seatback to provide enough overhead clearance to remove the head restraint.

BEFORE DRIVING

EXAMPLE

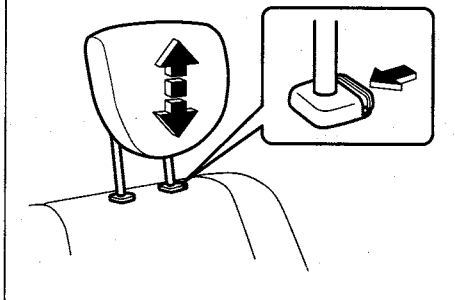

68KH013

To raise the rear head restraint, pull upward on the restraint until it clicks. To lower the restraint, push down on the restraint while holding in the lock lever. If a head restraint must be removed (for cleaning, replacement, etc.), push in the lock lever and pull the head restraint all the way out.

Folding Rear Seats

The rear seat(s) of your vehicle can be folded forward to provide additional cargo space.

To fold the rear seats forward:

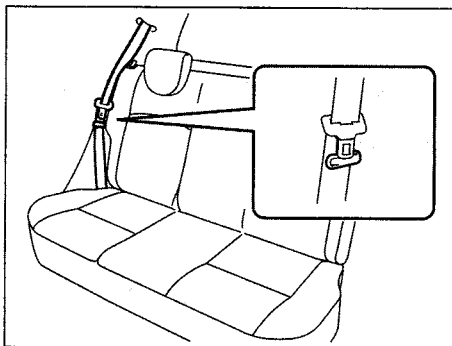

68KN038

- 1) Hook the webbing of the outboard lap-shoulder belts in the belt hangers.

CAUTION

- When you move a seatback, make sure the belt webbing is hooked in the seat belt hangers so the seat belts are not caught by the seatback, seat hinge, or seat latch. This helps prevent damage to the belt system.
- Make sure the belt webbing is not twisted.

- 2) Lower the adjustable head restraint fully.

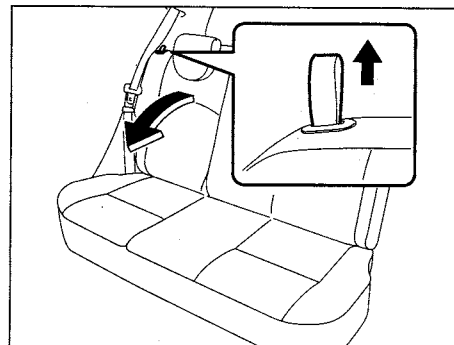

68KN039

- 3) Pull up the release straps on the top of the seat(s), and fold the seatback forward.

CAUTION

After folding the rear seatback forward, do not allow any foreign material to enter the lock opening. This may cause damage to the inside of the lock and prevent the seatback from being locked securely.

⚠ WARNING

If you need to carry cargo in the passenger compartment with the rear seat back folded forward, be sure to secure the cargo or it may be thrown about, causing injury. Never pile cargo higher than the seatbacks.

To return the seat to the normal position, follow the procedure below.

⚠ WARNING

When returning the rear seatback to the normal position, be careful that your finger is not caught between the lock and the striker.

CAUTION

When returning the rear seatback to the normal position, make sure that there is nothing around the striker. Any foreign materials prevent the seatback from being locked securely.

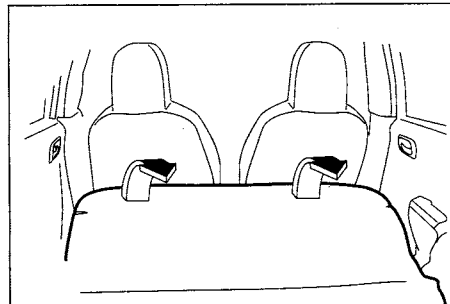
**EXAMPLE**

68KH035

Raise the seatback until it locks into place.

After returning the seat, try moving the seatback to make sure they are securely latched.

⚠ WARNING

Do not put your hand into the rear seatback lock opening, or your finger may get caught and be injured.

CAUTION

- When returning the rear seatback to the normal position, do not allow any foreign material to enter the lock opening. This may prevent the seatback from being locked securely.
- When returning the rear seatback to the normal position, be sure to handle it carefully by hand to avoid any damage to the lock itself. Do not push it by using some material or by applying excessive force.
- As the lock is designed exclusively for securing the rear seatback, do not use it for any other purpose. Incorrect use of it may cause damage to the inside of the lock and prevent the seatback from being locked securely.

BEFORE DRIVING

Seat Belts and Child Restraint Systems

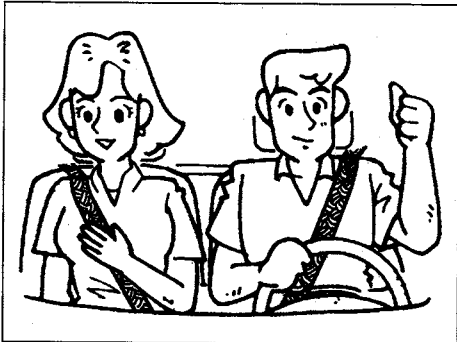

65D231S

⚠ WARNING

Wear Your Seat Belts at All Times.

⚠ WARNING

An air bag supplements, or adds to, the frontal crash protection offered by seat belts. The driver and all passengers must be properly restrained by wearing seat belts at all times, whether or not an air bag is mounted at their seating position, to minimize the risk of severe injury or death in the event of a crash.

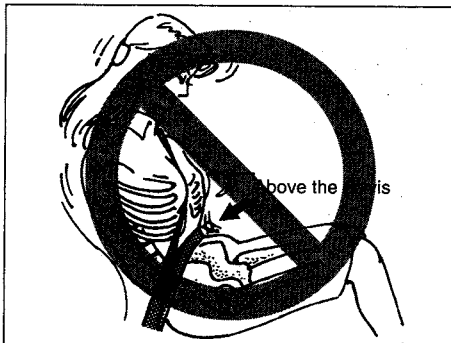

65D606

⚠ WARNING

- Never allow persons to ride in the cargo area of a vehicle. In the event of an accident, there is a much greater risk of injury for persons who are not riding in a seat with their seat belt securely fastened.
- Seat belts should always be adjusted as follows:
 - the lap portion of the belt should be worn low across the pelvis, not across the waist.
 - the shoulder straps should be worn on the outside shoulder only, and never under the arm.
 - the shoulder straps should be away from your face and neck, but not falling off your shoulder.

(Continued)

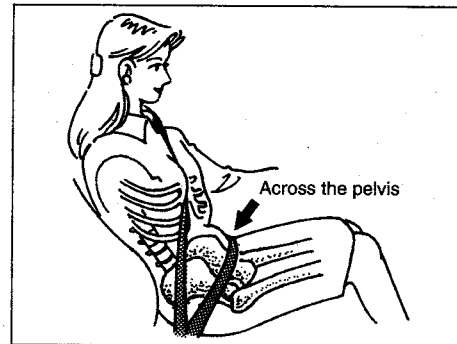

65D201

⚠ WARNING

(Continued)

- Seat belts should never be worn with the straps twisted and should be adjusted as tightly as is comfortable to provide the protection for which they have been designed. A slack belt will provide less protection than one which is snug.
- Make sure that each seat belt buckle is inserted into the proper buckle catch. It is possible to cross the buckles in the rear seat.

(Continued)

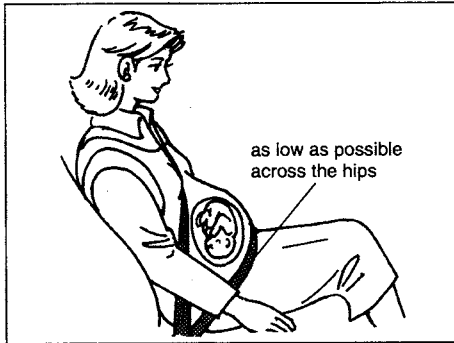

65D199

⚠ WARNING

(Continued)

- Pregnant women should use seat belts, although specific recommendations about driving should be made by the woman's medical advisor. Remember that the lap portion of the belt should be worn as low as possible across the hips, as shown in the diagram.
- Do not wear your seat belt over hard or breakable objects in your pockets or on your clothing. If an accident occurs, objects such as glasses, pens, etc. under the seat belt can cause injury.

(Continued)

⚠ WARNING

(Continued)

- Never use the same seat belt on more than one occupant and never attach a seat belt over an infant or child being held on an occupant's lap. Such seat belt use could cause serious injury in the event of an accident.
- Periodically inspect seat belt assemblies for excessive wear and damage. Seat belts should be replaced if webbing becomes frayed, contaminated, or damaged in any way. It is essential to replace the entire seat belt assembly after it has been worn in a severe impact, even if damage to the assembly is not obvious.
- Children age 12 and under should ride properly restrained in the rear seat.
- Infants and small children should never be transported unless they are properly restrained. Restraint systems for infants and small children can be purchased locally and should be used. Make sure that the system you purchase meets applicable safety standards. Read and follow all the directions provided by the manufacturer.

(Continued)

⚠ WARNING

(Continued)

- Avoid contamination of seat belt webbing by polishes, oils, chemicals, and particularly battery acid. Cleaning may safely be carried out using mild soap and water.
- For children, if the shoulder belt irritates the neck or face, move the child closer to the center of the vehicle.
- All seatbacks should always be in an upright position when driving, or seat belt effectiveness may be reduced. Seat belts are designed to offer maximum protection when seatbacks are in the upright position.

BEFORE DRIVING

Lap-Shoulder Belt

Emergency Locking Retractor (ELR)

The seat belt has an emergency locking retractor (ELR), which is designed to lock the seat belt only during a sudden stop or impact. It also may lock if you pull the belt across your body very quickly. If this happens, let the belt go back to unlock it, then pull the belt across your body more slowly.

Automatic Locking Retractor (ALR)

The rear outboard seat belts have emergency locking retractors (ELRs) that can be temporarily converted to function as automatic locking retractors (ALRs). The ALR mode should be used if you need to secure a child restraint system in the seat. Refer to the "Child Restraint Systems" section for details.

Safety reminder

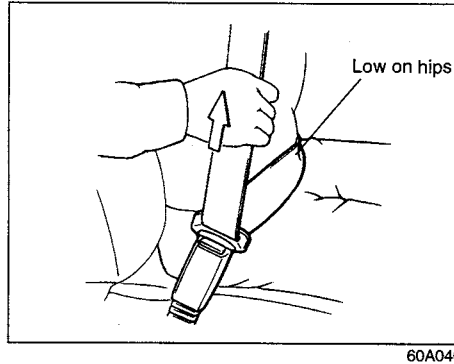
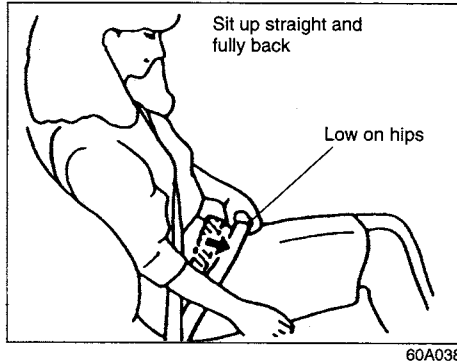

To reduce the risk of sliding under the belt during a collision, position the lap portion of the belt across your lap as low on your hips as possible and adjust it to a snug fit by pulling the shoulder portion of the belt upward through the latch plate. The length of the diagonal shoulder strap adjusts itself to allow freedom of movement.

All Seat Belts

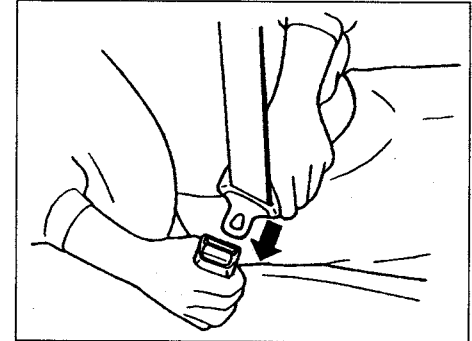

To fasten the seat belt, sit up straight and well back in the seat, pull the latch plate attached to the seat belt across your body and press it into the buckle until you hear a "click".

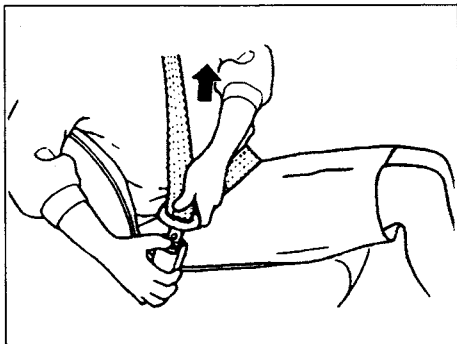

60A039

To unfasten the belt, push the button on the buckle and allow the belt to retract.

Driver's Seat Belt Reminder

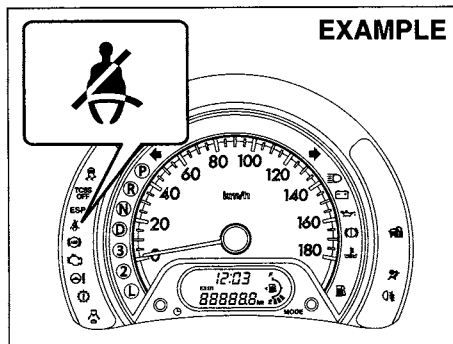

68KM018

When the driver doesn't buckle his or her seat belt, the driver's seat belt reminder light in the instrument cluster will come on or blink and a buzzer will sound as a reminder to the driver to buckle his or her seat belt. For more details, refer to the explanation below.

If the driver's seat belt remains unbuckled when the ignition switch is turned to the "ON" position, the reminder works as follows:

- 1) The driver's seat belt reminder light will come on.
- 2) After the vehicle's speed has reached about 15 km/h, the driver's seat belt reminder light will blink and a buzzer will sound for about 95 seconds.

- 3) After step 2) has finished, the reminder light will remain on until the driver's seat belt is buckled.

If the driver has buckled his or her seat belt and later unbuckles the seat belt, the reminder system will be activated from step 1) or step 2) according to the vehicle's speed. When the vehicle's speed is below about 15 km/h, the reminder will start from step 1). When the vehicle's speed is above about 15 km/h, the reminder will start from step 2).

The reminder will be automatically canceled when the driver's seat belt is buckled or the ignition switch is turned off.

⚠ WARNING

It is absolutely essential that the driver and passengers wear their seat belts at all times. Persons who are not wearing seat belts have a much greater risk of injury if an accident occurs. Make a regular habit of buckling your seat belt before putting the key in the ignition.

BEFORE DRIVING

Seat Belt Hanger

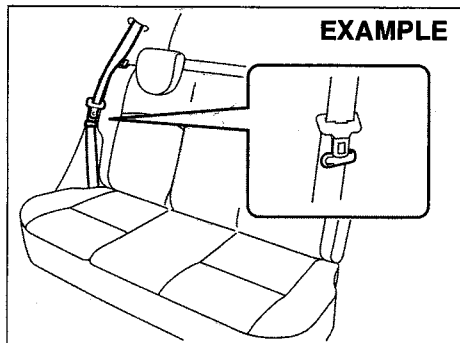

66KN038

CAUTION

- When you move a seatback, make sure the webbing is hooked in the seat belt hangers so the seat belts are not caught by the seatback, seat hinge, or seat latch. This helps prevent damage to the belt system.
- Make sure the belt webbing is not twisted.

Seat Belt Inspection

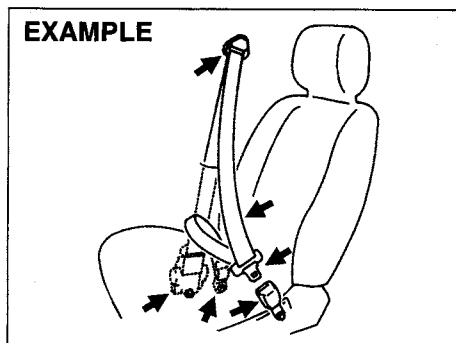

66D209S

Periodically inspect the seat belts to make sure they work properly and are not damaged. Check the webbing, buckles, latch plates, retractors, anchorages, and guide loops. Replace any seat belts which do not work properly or are damaged.

⚠ WARNING

Be sure to inspect all seat belt assemblies after any collision. Any seat belt assembly which was in use during a collision (other than a very minor one) should be replaced, even if damage to the assembly is not obvious. Any seat belt assembly which was not in use during a collision should be replaced if it does not function properly, it is damaged in any way or the seat belt pretensioner was activated.

Child Restraint Systems

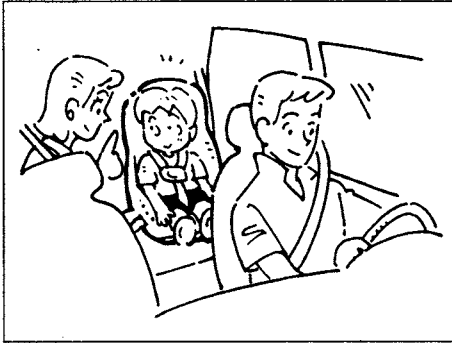

60G332S

Child restraint

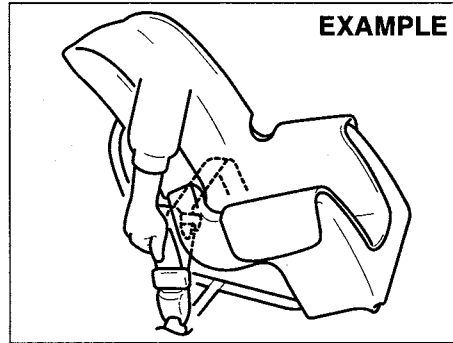

79J222

Infant restraint

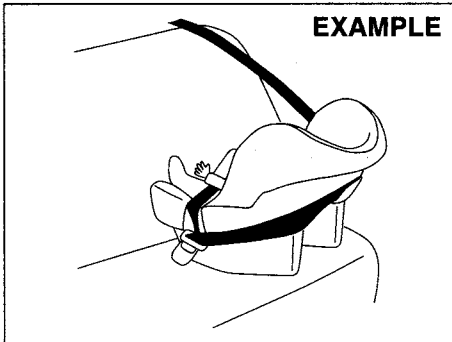

79J221

Booster seat

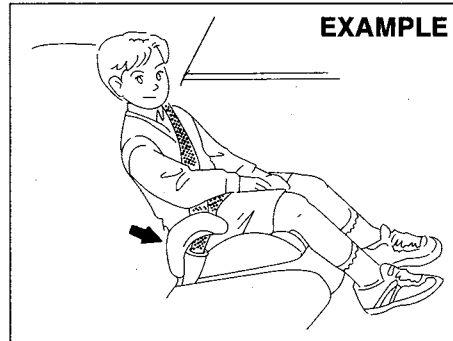

79J223

SUZUKI highly recommends that you use a child restraint system to restrain infants and small children. Many different types of child restraint systems are available; make sure that the restraint system you select meets applicable safety standards.

All child restraint systems are designed to be secured on vehicle seats by either seat belts (lap belts or the lap portion of lap-shoulder belts) or by special rigid lower anchor bars built into the seat. Whenever possible, SUZUKI recommends that child restraint systems be installed on the rear seat. According to accident statistics, children are safer when properly restrained in rear seating positions than in front seating positions.

If you must use a front-facing child restraint in the front passenger's seat, adjust the passenger's seat as far back as possible.

(For EU countries)

When purchasing a child restraint and install it to your SUZUKI, refer to the information about suitability for child restraints shown in "Child Restraint System for EU Countries" in this section.

NOTE:

Observe any statutory regulation about child restraints.



65D607

⚠ WARNING

If you install a child restraint system in the rear seat, slide the front seat far enough forward so that the child's feet do not touch the front seatback. This will help avoid injury to the child in the event of an accident.



65D608

⚠ WARNING

If your vehicle is equipped with a front passenger air bag, do not install a rear-facing child restraint in the front passenger's seat. If the passenger's air bag inflates, a child in a rear-facing child restraint could be killed or seriously injured. The back of a rear-facing child restraint would be too close to the inflating air bag.



65D609

⚠ WARNING

Children could be endangered in a crash if their child restraints are not properly secured in the vehicle. When installing a child restraint system, be sure to follow the instructions below. Be sure to secure the child in the restraint system according to the manufacturer's instructions.

 **WARNING**

If your vehicle is equipped with side air bags, do not install a child restraint in the front passenger's seat. If the passenger's side air bag inflates, a child in a child restraint could be severely injured.

BEFORE DRIVING

Child Restraint System for EU Countries

Child Restraint

The suitability of each passenger's seat position for carriage of children and fitting of child restraint system is shown in the table below. Whenever you carry children under 12 years of age or smaller than 150 cm, properly use the child restraints which conform to ECE-R Norm 44, the standard for child restraints, referring to the table.

Table of vehicle handbook information on child restraint systems installation suitability for various seating positions

Mass Group		Seating position (or other site)				
		Front Passenger	Rear Outboard	Rear Center	Intermediate Outboard	Intermediate Center
group 0	up to 10 kg	X	U	N.A.	N.A.	N.A.
group 0+	up to 13 kg	X	U*	N.A.	N.A.	N.A.
group I	9 to 18 kg	X	U	N.A.	N.A.	N.A.
group II	15 to 25 kg	X	UF	N.A.	N.A.	N.A.
group III	22 to 36 kg	X	UF	N.A.	N.A.	N.A.

Key of letters to be inserted in the above table:

U =Suitable for 'universal' category restraints approved for use in this mass group

* SUZUKI recommends RÖMER Babysafe rearward child restraint system. (SUZUKI Genuine Accessory part number: 990E0-59J14-000)

UF =Suitable for forward-facing 'universal' category restraints approved for use in this mass group

L =Suitable for particular child restraints given on attached list.

These restraints may be of the 'specific vehicle', 'restricted' or 'semi-universal' categories.

B =Built-in restraint approved for this mass group

X =Seat position not suitable for children in this mass group

NOTE:

'universal' is the category in the ECE regulation-Norm 44.

Table of vehicle handbook information on ISOFIX child restraint systems installation suitability for various ISOFIX positions

Mass Group	Size class	Fixture	Vehicle ISOFIX positions					
			Front Passenger	Rear Outboard	Rear Center	Intermediate Outboard	Intermediate Center	Others sites
carrycot	F	ISO/L1	N.A.	X	N.A.	N.A.	N.A.	N.A.
	G	ISO/L2	N.A.	X	N.A.	N.A.	N.A.	N.A.
		1)	N.A.	N.A.	N.A.	N.A.	N.A.	N.A.
group 0 up to 10 kg	E	ISO/R1	N.A.	IL ²⁾	N.A.	N.A.	N.A.	N.A.
		1)	N.A.	N.A.	N.A.	N.A.	N.A.	N.A.
group 0+ up to 13 kg	E	ISO/R1	N.A.	IL ²⁾	N.A.	N.A.	N.A.	N.A.
	D	ISO/R2	N.A.	IL ²⁾	N.A.	N.A.	N.A.	N.A.
	C	ISO/R3	N.A.	IL ³⁾	N.A.	N.A.	N.A.	N.A.
		1)	N.A.	N.A.	N.A.	N.A.	N.A.	N.A.
group I 9 to 18 kg	D	ISO/R2	N.A.	IL ²⁾	N.A.	N.A.	N.A.	N.A.
	C	ISO/R3	N.A.	IL ³⁾	N.A.	N.A.	N.A.	N.A.
	B	ISO/F2	N.A.	IUF	N.A.	N.A.	N.A.	N.A.
	B1	ISO/F2X	N.A.	IUF	N.A.	N.A.	N.A.	N.A.
	A	ISO/F3	N.A.	IL	N.A.	N.A.	N.A.	N.A.
		1)	N.A.	N.A.	N.A.	N.A.	N.A.	N.A.
group II 15 to 25 kg		1)	N.A.	N.A.	N.A.	N.A.	N.A.	N.A.
group III 22 to 36 kg		1)	N.A.	N.A.	N.A.	N.A.	N.A.	N.A.

BEFORE DRIVING

- 1) For the CRS which do not carry the ISO/XX size class identification (A to G), for the applicable mass group, the car manufacturer shall indicate the vehicle specific ISOFIX child restraint system(s) recommended for each position.

Key of letters to be inserted in the above tables

IUF=suitable for ISOFIX forward child restraints systems of universal category approved for use in the mass group

SUZUKI recommends RÖMER DUO plus. (SUZUKI Genuine Accessory part number: 99000-990YA-020)

IL =suitable for particular ISOFIX CRS are those of the "specific vehicle", "restricted" or "semi-universal" categories.

X =ISOFIX position not suitable for ISOFIX child restraint systems in this mass group and / or this size class."

NOTE:

Front seat longitudinal adjustment (Middle position: 12 notches rearward to the foremost position);

2) 10 notches rearward to the foremost position

3) 3 notches rearward to the foremost position

Installation with Lap-Shoulder Seat Belts

NOTE:

There are two types of lap-shoulder belts depending on the vehicle's specification, A-ELR (Automatic-Emergency Locking Retractor) type and ELR (Emergency Locking Retractor) type.

The A-ELR type belts have emergency locking retractors (ELRs) that can be temporarily converted to function as automatic locking retractors (ALRs).

The ELR type belts have ELRs that cannot be converted to function as ALRs.

To identify the belt is the A-ELR type or the ELR type, slowly pull all of the shoulder webbing out of the retractor. Then let the webbing retract a little and pull it out, and repeat this a few times. If the belt is locked each time you pull the belt, the belt is the A-ELR type. If the belt is not locked, the belt is the ELR type.

Please note that the methods to secure the child restraint system with the ELR lap-shoulder belt and with the A-ELR lap-shoulder belt are different.

ELR type belt

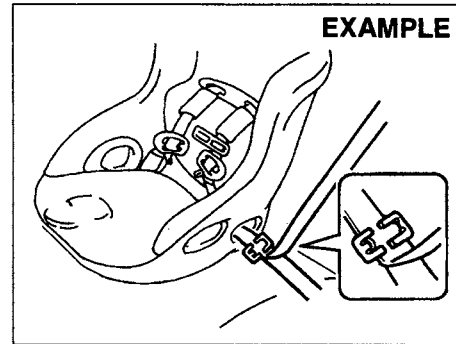

80JC021

Install your child restraint system according to the instructions provided by the child restraint system manufacturer.

Make sure that the seat belt is securely latched.

Try to move the child restraint system in all directions to make sure it is securely installed.

A-ELR type belt

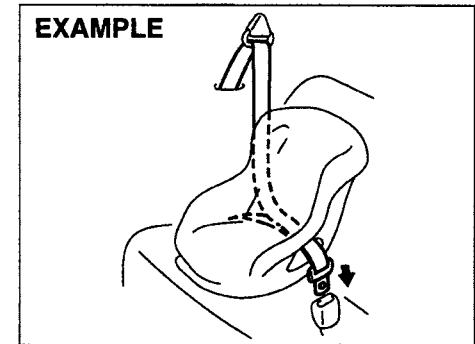

83E031

Install your child restraint system according to the instructions provided by the child restraint system manufacturer.

Make sure that the seat belt is securely latched.

After making sure that the seat belt is securely latched:

BEFORE DRIVING

A-ELR type

EXAMPLE

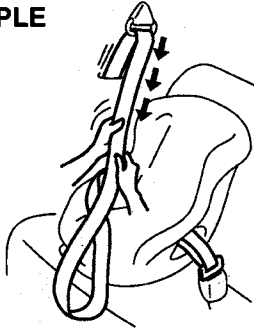

83E035

- 1) Slowly pull all of the remaining webbing out of the retractor. You may hear a click, which means that the emergency locking retractor (ELR) has converted to function as an automatic locking retractor (ALR).

A-ELR type

EXAMPLE

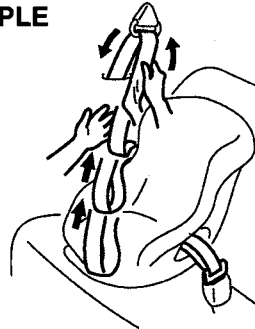

83E032

- 2) Allow the extra webbing to retract, and pull the webbing toward the retractor to take up any slack. Make sure that the lap portion of the belt is tight around the child restraint system and the shoulder portion of the belt is positioned so that it cannot interfere with the child's head or neck.

A-ELR type

EXAMPLE

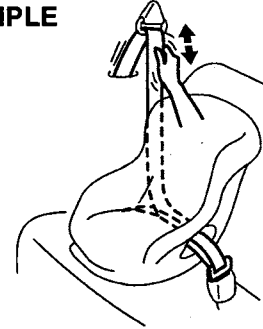

83E036

- 3) Make sure that the retractor has converted to the ALR mode by trying to pull webbing out of the retractor. If the retractor is in the ALR mode, the belt will be locked.

▲ WARNING

If the retractor is not in the ALR mode, the child restraint system can move or tip over when your vehicle turns or stops abruptly.

A-ELR type

EXAMPLE

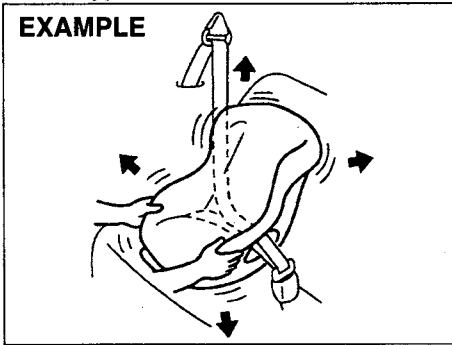

65D234

A-ELR type (to revert from ALR to ELR)

EXAMPLE

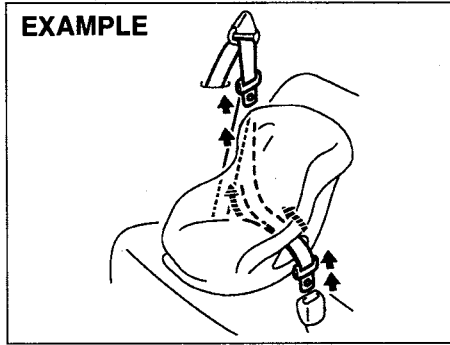

65D267

When you unbuckle the seat belt and allow it to retract to a certain length, the retractor will automatically revert back to the normal ELR mode.

A-ELR type

EXAMPLE

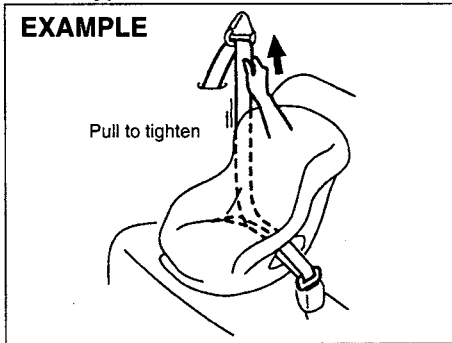

65D235

- 4) Try moving the child restraint system in all directions, to make sure it is securely installed. If you need to tighten the belt, pull more webbing toward the retractor.

Installation with ISOFIX type Anchages

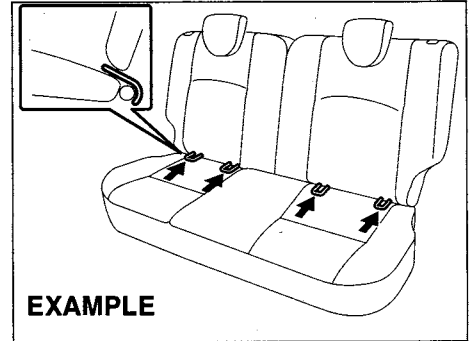

EXAMPLE

68KM092

Your vehicle is equipped with the lower anchorages in the rear seat outboard seating positions for securing a ISOFIX type of child restraints with the connecting bars. The lower anchorages are located where the rear of the seat cushion meets the bottom of the seatback.

⚠ WARNING

Be sure to install the ISOFIX type of child restraint(s) on the only outboard seating positions, not on the central position for rear seat.

BEFORE DRIVING

Install the ISOFIX type child restraint system according to the instructions provided by the child restraint system manufacturer. After installing try moving the child restraint system in all directions especially forward, to make sure the connecting bars are securely latched to the anchorages.

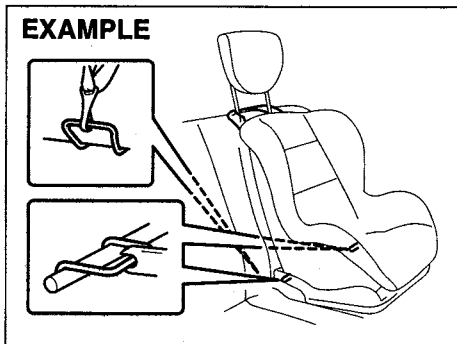

If your vehicle is equipped with the top strap anchorages, be sure to use the top strap of the child restraint according to the instructions provided by the child restraint system manufacturer.

Here is a general instruction:

- 1) Pull upward on the rear head restraint until it clicks.

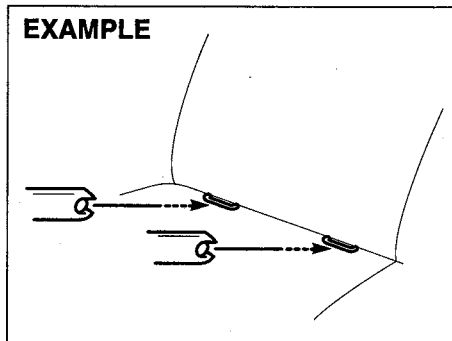

CAUTION

Before installing a child restraint system in the rear seat, raise the head restraint to the most upper position.

- 2) Place the child restraint on the rear seat, inserting the connecting bars to the anchorages between the seat cushion and the seatback.

EXAMPLE

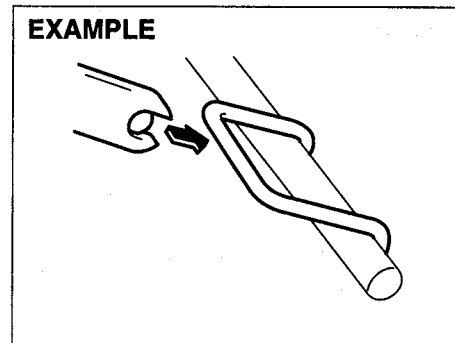

54G183

- 3) Use your hands to carefully align the connecting bar tips with the anchorages. Take care not to pinch your fingers.

EXAMPLE

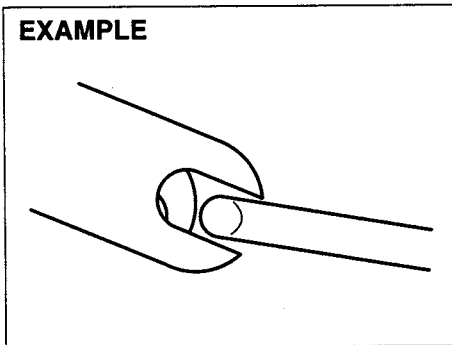

54G184

- 4) Push the child restraint toward the anchorages so that the connecting bar tips are partially hooked to the anchorages. Use your hands to confirm the position.

EXAMPLE

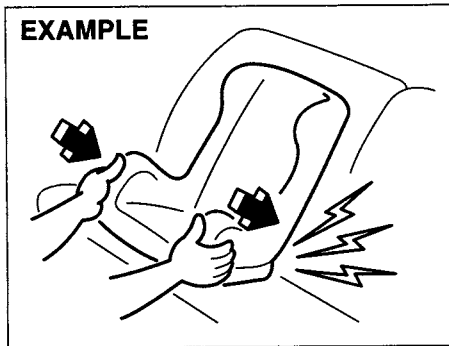

54G185

- 5) Grasp the front of the child restraint and push the child restraint forcefully to latch the connecting bars. Make sure they are securely latched by trying to move the child restraint system in all directions, especially forward.
- 6) Attach the top strap referring to "Installation of Child Restraint with Top Strap" section below (if equipped).

Installation of Child Restraint with Top Strap

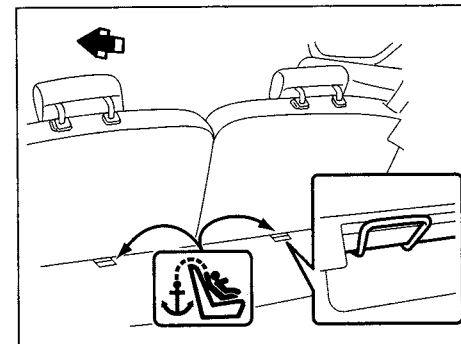

68KS017

Some child restraint systems require the use of a top strap. Top strap anchor brackets are located on the floor of the luggage compartment. The number of the anchor bracket provided in your vehicle depends on the vehicle specification. Install the child restraint system as follows:

- 1) Remove the luggage area cover.
- 2) Secure the child restraint on the rear seat using the procedure described above for securing a restraint system that does not require a top strap.

BEFORE DRIVING

- Hook the top strap to the anchor bracket and tighten the top strap according to the instructions provided by the child restraint system manufacturer. Be sure to attach the top strap to the corresponding anchor located directly behind the child restraint. Do not attach the top strap to the luggage restraint loops (if equipped).

⚠ WARNING

Do not attach the child restraint top strap to the luggage restraint loops (if equipped). Incorrectly attached top strap will reduce the intended effectiveness of the child restraint system.

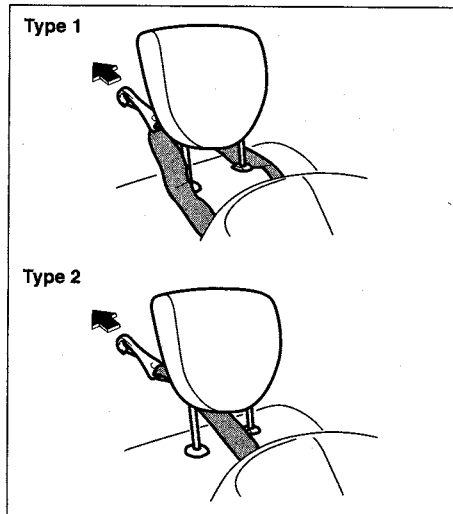

68KM022

- When routing the top strap, be sure to pass the top strap as shown in the illustration. (Refer to "Head Restraints" section for details on how to raise or lower the head restraint.)
- Make sure that cargo does not interfere with routing of the top strap.

Seat Belt Pretensioner System (if equipped)

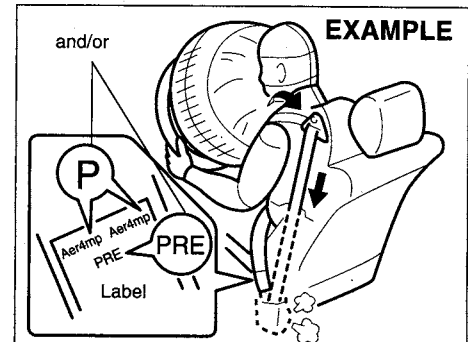

63J269

⚠ WARNING

This section of the owner's manual describes your SUZUKI's SEAT BELT PRETENSIONER SYSTEM. Please read and follow ALL these instructions carefully to minimize your risk of severe injury or death.

To determine if your vehicle is equipped with a seat belt pretensioner system at the front seating positions, check the label on the front seat belt at the bottom part. If the letters "p" and/or "PRE" appear as illustrated, your vehicle is equipped with the seat belt pretensioner system. You can use the pretensioner seat belts in the same manner as ordinary seat belts.

Read this section and the “Supplemental Restraint System (air bags)” section to learn more about the pretensioner system.

The seat belt pretensioner system works with the SUPPLEMENTAL RESTRAINT SYSTEM (Air Bags). The crash sensors and the electronic controller of the air bag system also control the seat belt pretensioners. When the air bags are triggered, the pretensioners are also triggered. For precautions and general information including servicing the pretensioner system, refer to the “Supplemental Restraint System (air bags)” section in addition to this “Seat Belt Pretensioner System” section, and follow all those precautions.

The pretensioner is located in each front seat belt retractor. The pretensioner tightens the seat belt so the belt fits the occupant's body more snugly in the event of a frontal crash. The retractors will remain locked after the pretensioners are activated. Upon activation, some noise will occur and some smoke may be released. These conditions are not harmful and do not indicate a fire in the vehicle.

The driver and all passengers must be properly restrained by wearing seat belts at all times, whether or not a pretensioner is equipped at their seating position, to minimize the risk of severe injury or death in the event of a crash.

Sit fully back in the seat; sit up straight; do not lean forward or sideways. Adjust the belt so the lap portion of the belt is worn low across the pelvis, not across the waist. Please refer to the “Seat Adjustment” section and the instructions and precautions about the seat belts in this “Seat Belts and Child Restraint Systems” section for details on proper seat and seat belt adjustments.

Please note that the pretensioners along with the air bags will activate only in severe frontal collisions. They are not designed to activate in rear impacts, side impacts, roll-overs, or minor frontal collisions. The pretensioners can be activated only once. If the pretensioners are activated (that is, if the air bags are activated), have the pretensioner system serviced by an authorized SUZUKI dealer as soon as possible.

If the “AIR BAG” light on the instrument cluster does not blink or come on briefly when the ignition switch is turned to the “ON” position, stays on for more than 10 seconds, or comes on while driving, the pretensioner system or the air bag system may not work properly. Have both systems inspected by an authorized SUZUKI dealer as soon as possible.

Service on or around the pretensioner system components or wiring must be performed only by an authorized SUZUKI dealer who is specially trained. Improper service could result in unintended activation of pretensioners or could render the pretensioner inoperative. Either of these two conditions may result in personal injury.

To prevent damage or unintended activation of the pretensioners, be sure the battery is disconnected and the ignition switch has been in the “LOCK” position for at least 90 seconds before performing any electrical service work on your SUZUKI.

Do not touch pretensioner system components or wiring. The wires are wrapped with yellow tape or yellow tubing, and the couplers are yellow. When scrapping your SUZUKI, ask your SUZUKI dealer, body repair shop, or scrap yard for assistance.

**Supplemental Restraint System (air bags)
(if equipped)**

⚠ WARNING

This section of the owner's manual describes the protection provided by your SUZUKI's SUPPLEMENTAL RESTRAINT SYSTEM (air bags). Please read and follow ALL these instructions carefully to minimize your risk of severe injury or death in the event of a collision.

Your vehicle is equipped with a Supplemental Restraint System consisting of the following components in addition to a lap-shoulder belt at each front seating position.

1. Driver's front air bag module
2. Front passenger's front air bag module
3. Side air bag module (if equipped)
4. Side curtain air bag module (if equipped)
5. Seat belt pretensioners
6. Air bag controller
7. Forward crash sensor
8. Side crash sensor (if equipped)

EXAMPLE

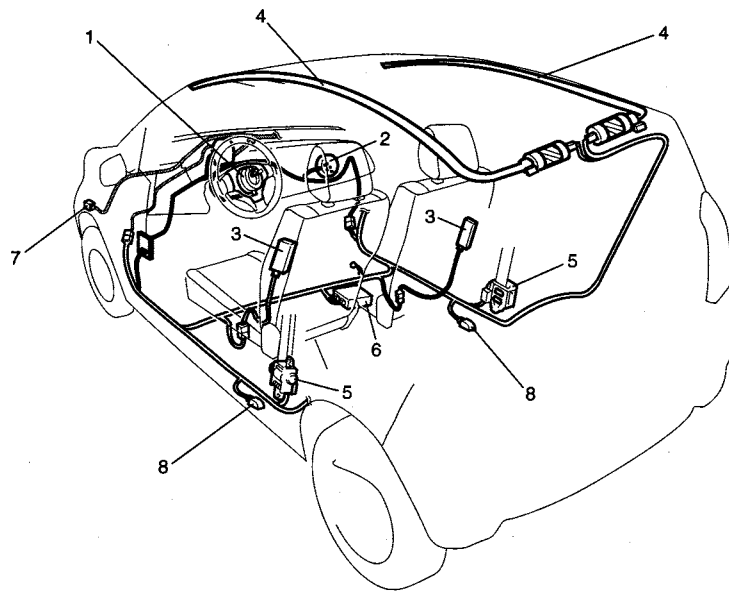

68KM087



63J030

If the "AIR BAG" light on the instrument cluster does not blink or come on when the ignition switch is first turned to the "ON" position, or the "AIR BAG" light stays on, or comes on while driving, the air bag system (or the seat belt pretensioner system) may not work properly. Have the air bag system inspected by an authorized SUZUKI dealer as soon as possible.

Front Air Bags

EXAMPLE

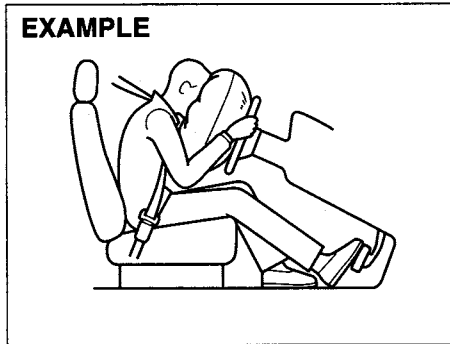

63J259

EXAMPLE

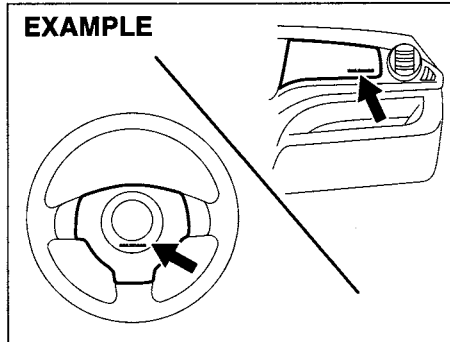

68KM023

The driver's front air bag is located behind the center pad of the steering wheel and the front passenger's front air bag is located behind the passenger's side of the

dashboard. The words "SRS AIRBAG" are molded into the air bag covers to identify the location of the air bags.

Frontal collision range

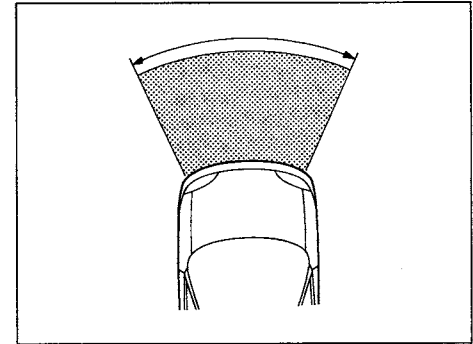

60G032

Front air bags are designed to inflate only in severe frontal collisions.

BEFORE DRIVING

Front air bags will not inflate

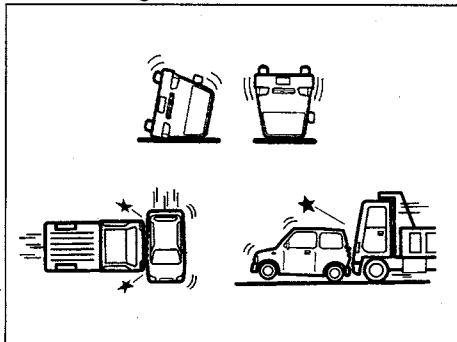

65D236

Front air bags will probably not inflate

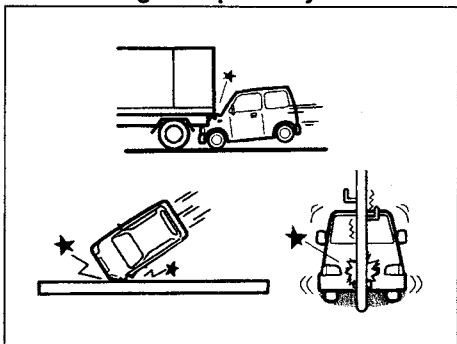

65D237

Front air bags are not designed to inflate in rear impacts, side impacts, rollovers or minor frontal collisions, since they would offer no protection in those types of acci-

dents. Remember, since an air bag deploys only one time during an accident, seat belts are needed to restrain occupants from further movements during the accident.

Therefore, an air bag is NOT a substitute for seat belts. To maximize your protection, **ALWAYS WEAR YOUR SEAT BELTS**. Be aware that no system can prevent all possible injuries that may occur in an accident.

WARNING

An air bag supplements, or adds to, the crash protection offered by seat belts. The driver and all passengers must be properly restrained by wearing seat belts at all times, whether or not an air bag is mounted at their seating position, to minimize the risk of severe injury or death in the event of a crash.



65D607

WARNING

Do not install a rear-facing child restraint in the front passenger's seat. If the passenger's front air bag inflates, a child in a rear-facing child restraint could be killed or severely injured. The back of a rear-facing child restraint would be too close to the inflating air bag.

If you must use a front-facing child restraint in the front passenger's seat, be sure to move the front passenger's seat as far back as possible.

Please refer to the "Seat Belts and Child Restraint Systems" section in this section for details on securing your child.

Air bag symbol (if equipped)

EXAMPLE



DO NOT place rear-facing child seat on this seat with airbag. **DEATH OR SERIOUS INJURY** can occur. The **BACK SEAT** with child restraint is the **SAFEST** place for children.

51KM035

You may find this label on the sun visor.

Side Air Bags and Side Curtain Air Bags (if equipped)

EXAMPLE

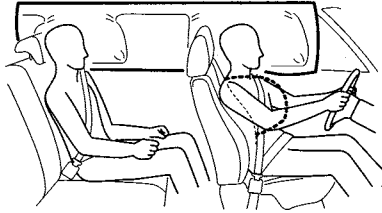

68KM090

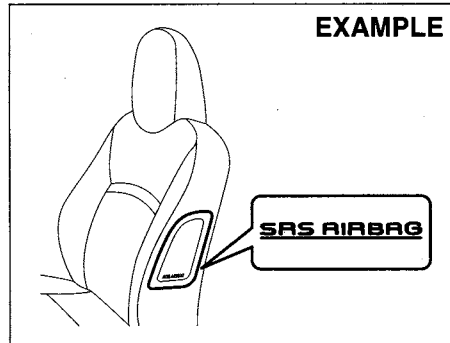

68KM024

Side air bags (if equipped) are located in the part of the front seatbacks closest to the doors. The words "SRS AIRBAG" are molded into the side air bag cover to identify the location of the side air bags.

⚠ WARNING

If your vehicle is equipped with side air bags, do not install a child restraint in the front passenger's seat. If the passenger's side air bag inflates, a child in a child restraint could be injured.

EXAMPLE

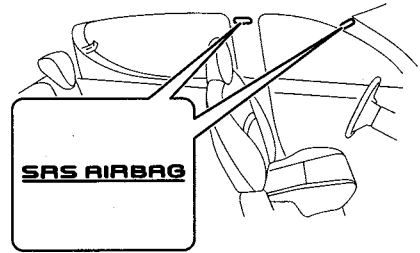

68KM025

Side curtain air bags (if equipped) are located in the roof lining. The words "SRS AIRBAG" are molded into the pillar to identify the location of the side curtain air bags.

BEFORE DRIVING

Side collision range

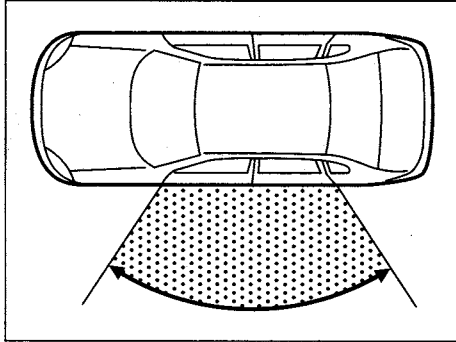

54G026

Side air bags and side curtain air bags are designed to inflate only in severe side impact collisions.

Side air bags and side curtain air bags will not inflate

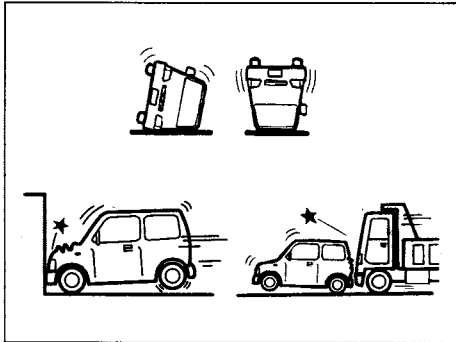

54G027

Side air bags and side curtain air bags will probably not inflate

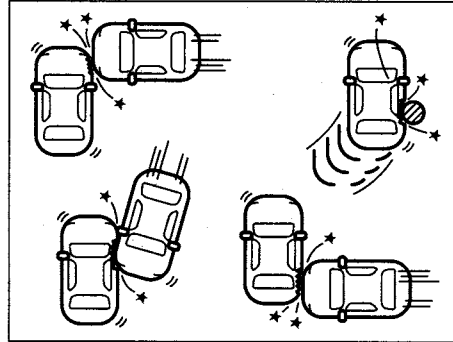

54G028

Side air bags and side curtain air bags are not designed to inflate in frontal or rear collisions, rollovers or minor side collisions, since they would offer no protection in those types of accidents. Only the side air bag and side curtain air bag on the side of the vehicle that is struck will inflate. Remember, since an air bag deploys only one time during an accident, seat belts are needed to restrain occupants from further movements during the accident.

Therefore, an air bag is NOT a substitute for seat belts. To maximize your protection, **ALWAYS WEAR YOUR SEAT BELTS.** Be aware that no system can prevent all possible injuries that may occur in an accident.

⚠ WARNING

An air bag supplements, or adds to, the crash protection offered by seat belts. The driver and all passengers must be properly restrained by wearing seat belts at all times, whether or not an air bag is mounted at their seating position, to minimize the risk of severe injury or death in the event of a crash.

How the system works

In a frontal collision, the crash sensors will detect rapid deceleration, and if the controller judges that the deceleration represents a severe frontal crash, the controller will trigger the inflators. If your vehicle is equipped with side air bags and side curtain air bags, crash sensors will detect a side collision, and if the controller judges that the side collision is severe enough, it will trigger a side inflator. The inflators inflate the appropriate air bags with nitrogen or argon gas. The inflated air bags provide a cushion for your head (front air bags and side curtain air bags only) and upper body. The air bag inflates and deflates so quickly that you may not even realize that it has activated. The air bag will neither hinder your view nor make it harder to exit the vehicle.

Air bags must inflate quickly and forcefully in order to reduce the chance of serious or fatal injuries. However, an unavoidable consequence of the quick inflation is that the air bag may irritate bare skin, such as the facial area against a front air bag. Also, upon inflation, a loud noise will occur and some powder and smoke will be released. These conditions are not harmful and do not indicate a fire in the car. Be aware, however, that some air bag components may be hot for a while after inflation.

A seat belt helps keep you in the proper position for maximum protection when an air bag inflates. Adjust your seat as far back as possible while still maintaining control of the vehicle. Sit fully back in your seat; sit up straight; do not lean over the steering wheel or dashboard. Front occupants should not lean on or sleep against the door. Please refer to the “Front Seat” section and the “Seat Belts and Child Restraint Systems” section in this section for details on proper seat and seat belt adjustments.



65D610

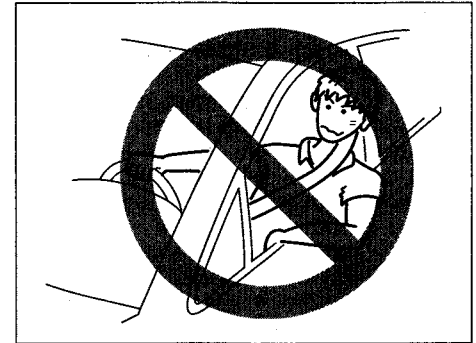

54G582

WARNING

- The driver should not lean over the steering wheel. The front passenger should not rest his or her body against the dashboard, or otherwise get too close to the dashboard. For vehicles with side air bags and side curtain air bag, occupants should not lean on or sleep against the door. In these situations, the out-of-position occupant would be too close to an inflating air bag, and may suffer severe injury.
- Do not attach any objects to, or place any objects over, the steering wheel or dashboard. Do not place any objects between the air bag and the driver or front passenger. These objects may interfere with air bag operation or may be propelled by the air bag in the event of a crash. Either of these conditions may cause severe injury.
- For vehicles with side air bags, do not place seat covers on the front seats, because seat covers could restrict the air bag's inflation. Also, do not place any cup holders on the door, as the cup holder could be propelled by the air bag in the event of a crash. Either of these conditions may cause severe injury.

Note that even though your vehicle may be moderately damaged in a collision, the collision may not have been severe enough to trigger the front or side air bags to inflate. If your car sustains ANY front-end or side damage, have the air bag system inspected by an authorized SUZUKI dealer to ensure it is in proper working order.

Your vehicle is equipped with a diagnostic module which records information about the air bag system if the air bags deploy in a crash. The module records information about overall system status, which sensors activated the deployment.

Servicing the air bag system

If the air bags inflate, have the air bags and related components replaced by an authorized SUZUKI dealer as soon as possible.

If your vehicle ever gets in deep water and the driver's floor is submerged, the air bag controller could be damaged. If it does, have the air bag system inspected by the SUZUKI dealer as soon as possible.

Special procedures are required for servicing or replacing an air bag. For that reason, only an authorized SUZUKI dealer should be allowed to service or replace your air bags. Please remind anyone who services your SUZUKI that it has air bags.

Service on or around air bag components or wiring must be performed only by an authorized SUZUKI dealer. Improper service could result in unintended air bag deployment or could render the air bag inoperative. Either of these two conditions may result in severe injury.

To prevent damage or unintended inflation of the air bag system, be sure the battery is disconnected and the ignition switch has been in the "LOCK" position for at least 90 seconds before performing any electrical service work on your SUZUKI. Do not touch air bag system components or wires. The wires are wrapped with yellow tape or yellow tubing, and the couplers are yellow for easy identification.

Scrapping a car that has an uninflated air bag can be hazardous. Ask your dealer, body repair shop or scrap yard for help with disposal.

Instrument Cluster

1. Speedometer
2. Odometer/Trip meter
3. Odometer/Trip meter selector knob
4. Tachometer
5. Fuel gauge
6. Warning and indicator lights

EXAMPLE

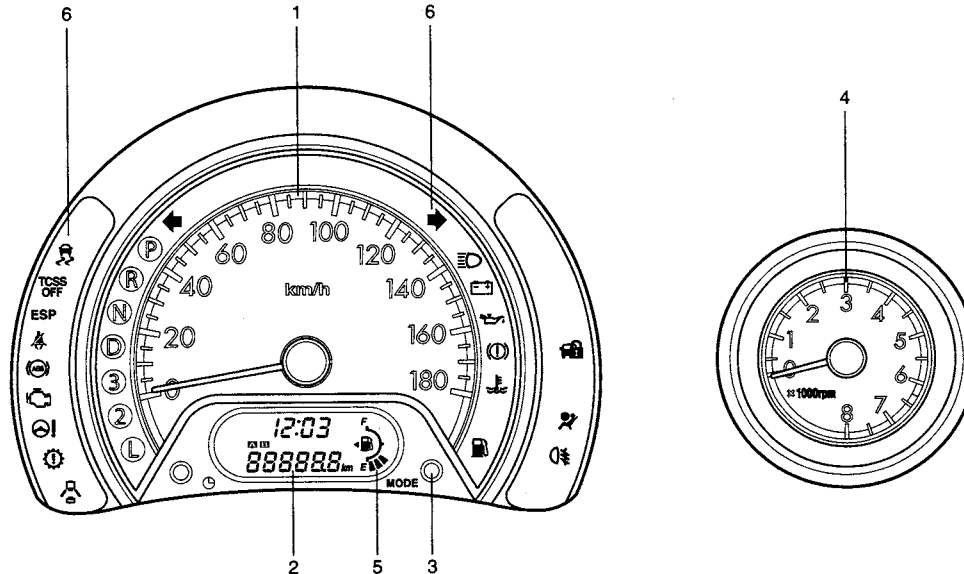

68KM026

Warning and Indicator Lights

Brake System Warning Light



60A072

Three different types of operations exist depending on the vehicle's specification.

- 1) The light comes on briefly when the ignition switch is turned to the "ON" position.
- 2) The light comes on when the parking brake is engaged with the ignition switch in the "ON" position.
- 3) The light comes on when under either or both of above two conditions.

The light also comes on when the fluid in the brake fluid reservoir falls below the specified level.

The light should go out after starting the engine and fully releasing the parking brake, if the fluid level in the brake fluid reservoir is adequate.

The light also comes on together with the ABS warning light when the rear brake force control function (proportioning valve function) of the ABS system fails.

If the brake system warning light comes on while you are driving the vehicle, it may mean that there is something wrong with the vehicle's brake system. If this happens, you should:

- 1) Pull off the road and stop carefully.

⚠ WARNING

Remember that stopping distance may be longer, you may have to push harder on the pedal, and the pedal may go down farther than normal.

- 2) Test the brakes by carefully starting and stopping at the side of the road.
 - If you determine that it is safe, drive carefully at low speed to the nearest dealer for repairs, or
 - Have the vehicle towed to the nearest dealer for repairs.

⚠ WARNING

If any of the following conditions occur, you should immediately ask your SUZUKI dealer to inspect the brake system.

- If the brake system warning light does not go out after the engine has been started and the parking brake has been fully released.
- If the brake system warning light does not come on when the ignition switch is turned to the "ON" position.
- If the brake system warning light comes on at any time during vehicle operation.

NOTE:

Because the disc brake system is self-adjusting, the fluid level will drop as the brake pads become worn. Replenishing the brake fluid reservoir is considered normal periodic maintenance.

Seat Belt Warning Light

60G049

This light blinks as a reminder until the driver's seat belt is buckled.

For details about the seat belt reminder, refer to "Seat Belts and Child Restraint Systems" in this section.

"AIR BAG" Light

63J030

This light blinks or comes on for several seconds when the ignition switch is turned to the "ON" position so you can check if the light is working.

The light will come on and stay on if there is a problem in the air bag system or the seat belt pretensioner system.

▲ WARNING

If the "AIR BAG" light does not blink or come on briefly when the ignition switch is turned to the "ON" position, stays on for more than 10 seconds, or comes on while driving, the air bag system or the seat belt pretensioner system may not work properly. Have both systems inspected by an authorized SUZUKI dealer.

Low Fuel Warning Light

54G343

If this light comes on, fill the fuel tank immediately.

NOTE:

The activation point of this light varies depending on road conditions (for example, slope or curve) and driving conditions because of fuel moving in the tank.

BEFORE DRIVING

Anti-Lock Brake System (ABS) Warning Light (if equipped)

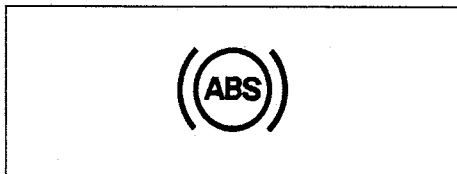

65D529

When the ignition switch is turned to the "ON" position, the light comes on briefly so you can check that the light is working.

If the light stays on, or comes on when driving, there may be something wrong with the ABS.

If this happens:

- 1) Pull off the road and stop carefully.
- 2) Turn the ignition switch to "LOCK" and then start the engine again.

If the warning light comes on briefly then turns off, the system is normal. If the warning light still stays on, the system will be something wrong.

If the light and the brake system warning light stay on, or come on simultaneously when driving, your ABS system is equipped with the rear brake force control function (proportioning valve function) and there may be something wrong with both the rear brake force control function and anti-lock function of the ABS system.

If one of these happens, have the system inspected by your SUZUKI dealer.

If the ABS becomes inoperative, the brake system will function as an ordinary brake system that does not have this ABS system.

"ESP" (Electronic Stability Program) Warning Light (if equipped)

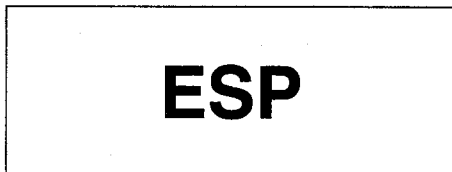

66J031

When the ignition switch is turned to the "ON" position, the light comes on briefly so you can check that the light is working. If the light stays on, or comes on when driving, there may be something wrong with the ESP[®] systems (other than ABS). You should have the system inspected by an authorized SUZUKI dealer.

For details of the ESP[®] systems, refer to "Electronic Stability Program (ESP[®])" in the "OPERATING YOUR VEHICLE" section.

Malfunction Indicator Light

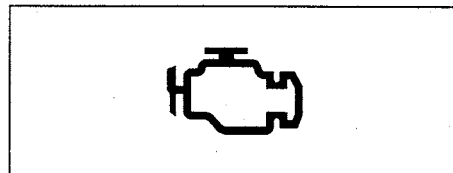

63J031

Your vehicle has a computer-controlled emission control system. A malfunction indicator light is provided on the instrument panel to indicate when it is necessary to have the emission control system serviced. The malfunction indicator light comes on when the ignition switch is turned to "ON" and goes out when the engine is started.

If the malfunction indicator light comes on when the engine is running, there is a problem with the emission control system. Bring the vehicle to your SUZUKI dealer to have the problem corrected.

CAUTION

Continuing to drive the vehicle when the malfunction indicator light is on can cause permanent damage to the vehicle's emission control system, and can affect fuel economy and driveability.

Electric Power Steering Light (if equipped)

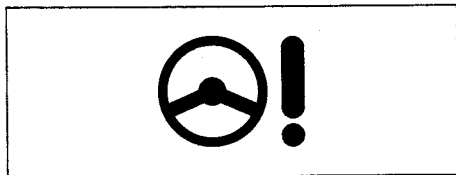

79J039

This light comes on when the ignition switch is turned to the "ON" position, and goes out when the engine is started.

If this light comes on while driving, the power steering system may not work properly. Have the system inspected by your SUZUKI dealer.

NOTE:

If the power steering system does not work properly, you will feel heavier to steer but you still will be able to steer.

Oil Pressure Light

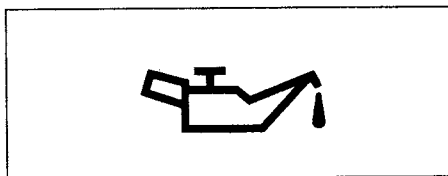

50G051

This light comes on when the ignition switch is turned to the "ON" position, and goes out when the engine is started. The light will come on and remain on if there is insufficient oil pressure. If the light comes on when driving, pull off the road as soon as you can and stop the engine.

Check the oil level and add oil if necessary. If there is enough oil, the lubrication system should be inspected by your SUZUKI dealer before you drive the vehicle again.

CAUTION

- If you operate the engine with this light on, severe engine damage can result.
- Do not rely on the Oil Pressure Light to indicate the need to add oil. Be sure to periodically check the engine oil level.

Charging Light

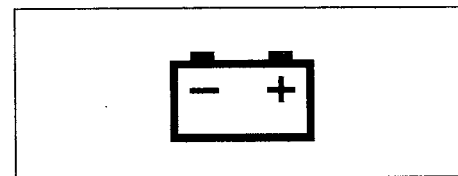

50G052

This light comes on when the ignition switch is turned to the "ON" position, and goes out when the engine is started. The light will come on and remain on if there is something wrong with the battery charging system. If the light comes on when the engine is running, the charging system should be inspected immediately by your SUZUKI dealer.

BEFORE DRIVING

High Engine Coolant Temperature Warning Light (red color)

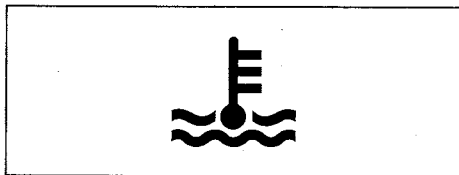

54G344

When the ignition switch is turned to the "ON" position, this light comes on briefly so you can check that the light is working. If this light blinks while driving, it means the engine is running hot. Avoid driving conditions that may lead to actual overheating. If the light stays on without blinking, then the engine is overheating. Follow the instructions in the "If the Engine Overheats" of "EMERGENCY SERVICE" section.

CAUTION

Continuing to drive the vehicle when engine overheating is indicated can result in severe engine damage.

Transaxle Warning Light (if equipped)



81A262

This light comes on for several seconds when the ignition switch is turned to the "ON" position so you can check the light is working. If this light comes on, there is the problem with the transaxle system. Ask your SUZUKI dealer to have the system inspected.

Immobilizer System Light (if equipped)

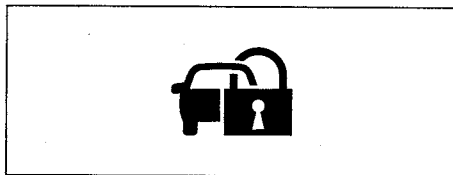

65D239

This light comes on when the ignition switch is turned to the "ON" position, and goes out when the engine is started. If this light blinks with the ignition switch turned to "ON", there may be something wrong with the immobilizer system. Ask your SUZUKI dealer to have the system inspected.

Open Door Warning Light (if equipped)

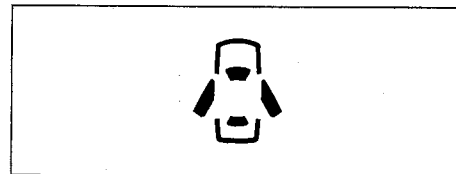

54G391

This light remains on until all doors (including the tailgate) are completely closed.

Turn Signal Indicators

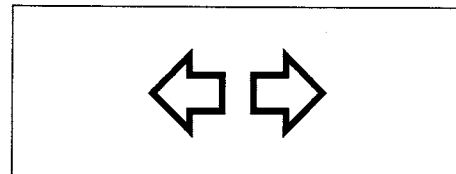

50G055

When you turn on the left or right turn signals, the corresponding green arrow on the instrument panel will flash along with the respective turn signal lights. When you turn on the hazard warning switch, both arrows will flash along with all of the turn signal lights.

Main Beam (high beam) Indicator Light

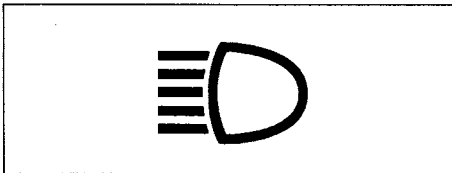

50G056

This indicator comes on when headlight main beams (high beams) are turned on.

“TCSS OFF” Indicator Light (if equipped)



52KM132

TCSS means the traction control system which is one of three systems included in ESP[®]; stability control system, traction control system, and anti-lock braking system.

When the ignition switch is turned to the “ON” position, this light comes on briefly so you can check that the light is working.

When the “TCSS OFF” switch is pushed to turn off the traction control system, the “TCSS OFF” light comes on and stays on.

NOTE:

If the traction control system operates continuously such as when driving on slippery roads, the traction control system may be canceled temporarily to avoid overheating the brake pads, and the light will come on. After a short period of time, the traction control system will turn on automatically and the light will go out.

For details of the traction control system, refer to “Electronic Stability Program (ESP[®])” in the “OPERATING YOUR VEHICLE” section.

SLIP Indicator Light (if equipped)



52KM133

ESP[®] is a registered trademark of Daimler AG.

This light blinks 5 times per second when one of the ESP[®] systems other than ABS is activated. If this light blinks, drive carefully.

When the ignition switch is turned to the “ON” position, the light comes on briefly so you can check that the light is working. If the light stays on, or comes on when driv-

ing and remains on, there may be something wrong with the ESP[®] systems (other than ABS). You should have the system inspected by an authorized SUZUKI dealer.

NOTE:

When you disconnect and re-connect the battery, ESP[®] system functions other than ABS will be deactivated and the slip indicator light will blink 1 time per second. For details on how to reactive the ESP[®] systems, refer to “SLIP Indicator Light” in the “OPERATING YOUR VEHICLE” section.

For details of the ESP[®] systems, refer to “Electronic Stability Program (ESP[®])” in the “OPERATING YOUR VEHICLE” section.

⚠ WARNING

The ESP[®] systems cannot prevent accidents. Always drive carefully.

Rear Fog Light Indicator Light

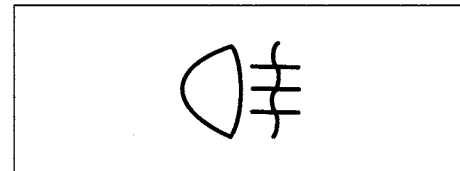

54G491

The rear fog light indicator light comes on when the rear fog light operates.

BEFORE DRIVING

Transaxle Selector Position Indicator (if equipped)

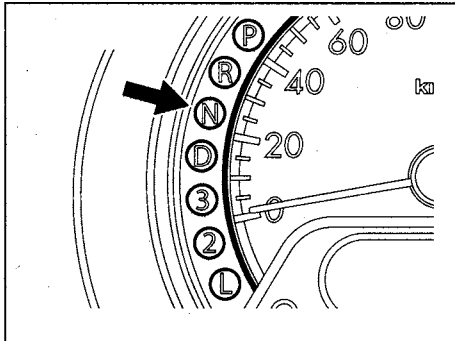

68KN021

When the ignition switch is in the "ON" position, the indicator shows the selector position of automatic transaxle.

Speedometer

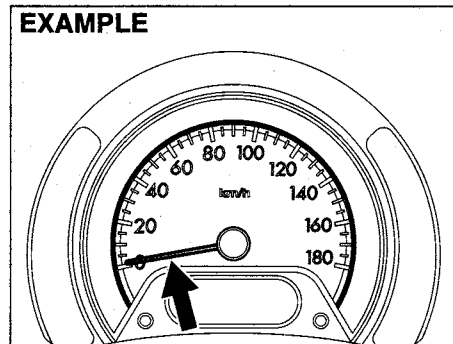

68KN025

The speedometer indicates vehicle speed in km/h and/or mph.

Tachometer (if equipped)

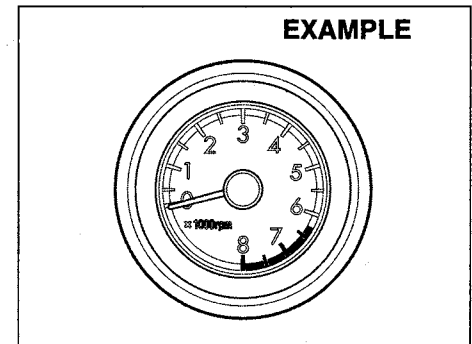

68KN026

The tachometer indicates engine speed in revolutions per minute.

CAUTION

Never drive with the engine speed indicator in the red zone or severe engine damage can result. When downshifting to a lower gear, make sure not to operate with excessive revolution speeds of the engine. Refer to "Downshifting maximum allowable speeds" in the "OPERATING YOUR VEHICLE" section.

Fuel Gauge

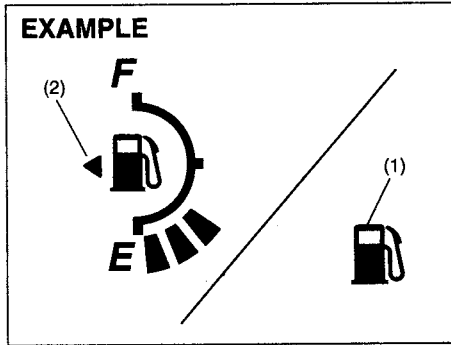

When the ignition switch is in the "ON" position, this gauge gives an approximate indication of the amount of fuel in the fuel tank. "F" stands for full and "E" stands for empty.

If the fuel meter indicator shows only one segment to "E", refill the tank as soon as possible.

If the low fuel warning light (1) comes on, fill the fuel tank immediately.

NOTE:

If the last segment blinks, it means that the fuel is almost empty.

NOTE:

The activation point of the low fuel warning light (1) varies depending on road conditions (for example, slope or curve) and driving conditions because of fuel moving in the tank.

The mark (2) indicates that the fuel filler door is located on the left side of the vehicle.

Information Display

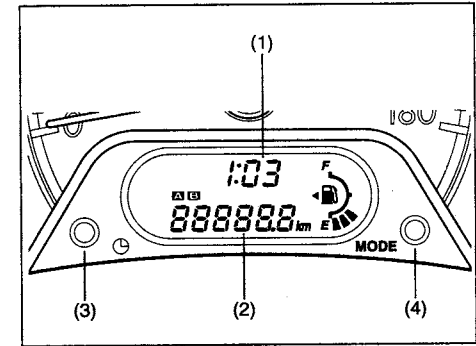

- (1) Clock
- (2) Odometer/Trip meter
- (3) Clock knob
- (4) "MODE" knob

BEFORE DRIVING

Clock (1)

The clock is shown when the ignition switch is in the "ON" position.

To set the clock, follow the instructions below.

- Hold in the clock knob (3) for more than 2 seconds. Push the clock knob (3) to advance the minute display while the minute display is flashing. Release the clock knob (3) for 5 seconds to set the minute display.
- The hour display flash after the minute display is set. Push the clock knob (3) to advance the hour display. Release the clock knob (3) for 5 seconds to set the hour display.

Odometer/Trip meter (2)

The odometer/trip meter is shown when the ignition switch is in the "ON" position.

The odometer records the total distance the vehicle has been driven. The trip meter can be used to measure the distance traveled on short trips or between fuel stops.

CAUTION

Keep track of your odometer reading and check the maintenance schedule regularly for required services. Increased wear or damage to certain parts can result from failure to perform required services at the proper mileage intervals.

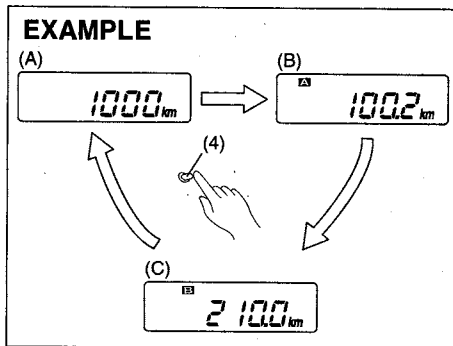

When the ignition switch is turned to "ON" with the lighting switch is in the "OFF" position, the display shows three types of indication; odometer (A), trip meter A (B) and trip meter B (C). Push the "MODE" knob (4) quickly to switch the indication among the three.

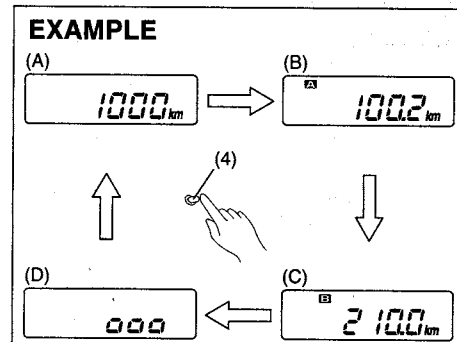

When the ignition switch is turned to "ON" and the position lights, tail lights and/or the headlights are on, the display shows four types of indication; odometer (A), tripmeter A (B), tripmeter B (C) and indication of illumination intensity (D). Push the "MODE" knob (4) quickly to switch the indication among the four. When the indication shows (D), you can control the meter illumination intensity. Refer to "Meter illumination control" section below for details on how to dim or brighten the meter illumination.

EXAMPLE

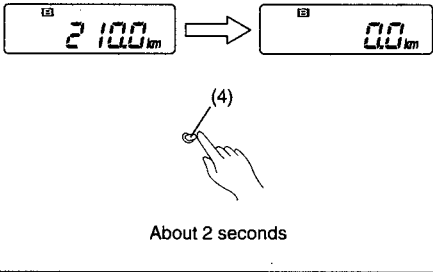

68KH019

To reset the trip meter to zero, hold the "MODE" knob (4) for about 2 seconds.

Meter illumination control

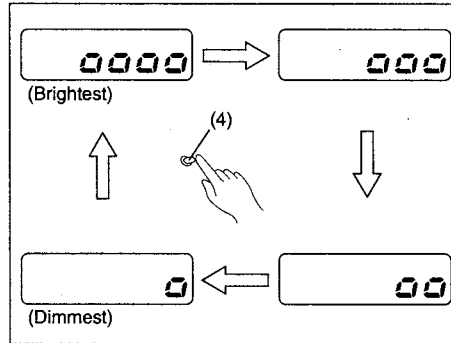

68KH102

When the display shows the indication of illumination intensity (D), you can dim or brighten the meter illumination.

To change the meter illumination brightness, push and hold in the "MODE" knob (4). The indication will change as shown in the illustration. The illumination gets dimmer then returns to the brightest condition after it reaches the dimmest.

Lighting Control Lever

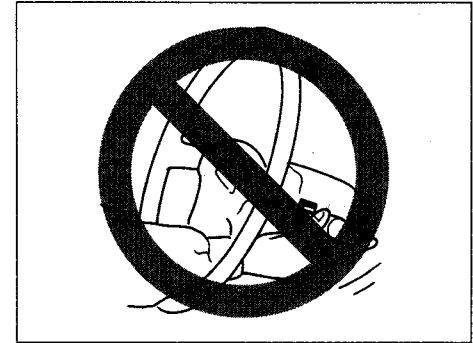

65D611

⚠ WARNING

To avoid possible injury, do not operate controls by reaching through the steering wheel.

BEFORE DRIVING

Lighting Operation

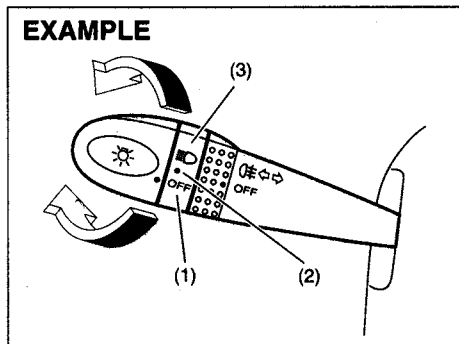

To turn the lights on or off, twist the knob on the end of the lever. There are three positions:

OFF (1)

All lights are off.

● (2)

Front position lights, tail lights, license plate light and instrument lights are on, but headlights are off.

☰ (3)

Front position lights, tail lights, license plate light, instrument lights and headlights are on.

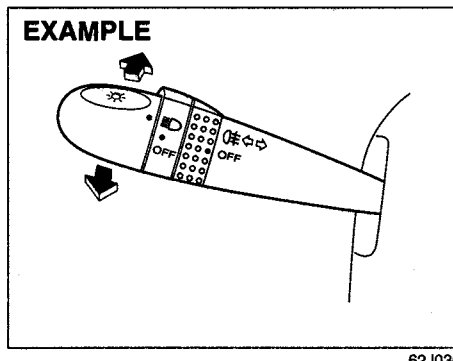

With the headlights on, push the lever forward to switch to the high beams (main beams) or pull the lever toward you to switch to the low beams. When the high beams (main beams) are on, a light on the instrument panel will come on. To momentarily activate the high beams (main beams) as a passing signal, pull the lever slightly toward you and release it when you have completed the signal.

Day time running light control (if equipped)

When the engine is started, this system turns on all lights. But this control is canceled when the light control lever is turned to any position other than "OFF".

Lights "On" reminder (if equipped)

A buzzer/chime sounds to remind you to turn off the lights if they are left on when the ignition key is removed and the driver's door is opened.

Front Fog Light Switch (if equipped)

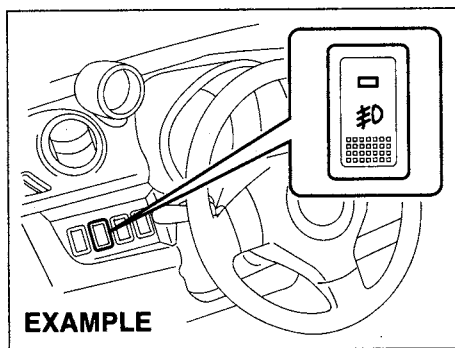

68KM029

The front fog light comes on when the fog light switch is pushed in with the position lights, tail lights and/or the headlights are on. An indicator light above the switch will be lit when the front fog light is on.

NOTE:

In some countries the lighting operation may be different from the above description according to local regulations.

Rear Fog Light Switch (if equipped)

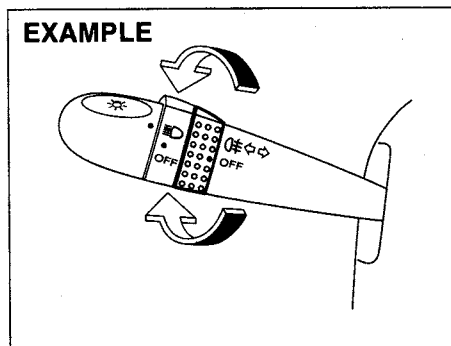

62J031

To turn the rear fog light on, twist the knob as shown in the illustration with the head lights are on. When the rear fog light is on, an indicator light on the instrument cluster will come on. Do not turn the rear fog light switch unless the head lights are on.

NOTE:

When the head light switch is returned to the "OFF" position, the rear fog light switch will be cancelled automatically.

Headlight Leveling Switch (if equipped)

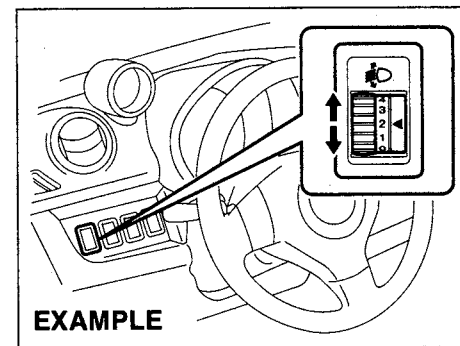

68KM030

Level the headlight beam according to the load condition of your vehicle by turning this switch. The chart below shows the appropriate switch position for different vehicle-load conditions.

BEFORE DRIVING

Vehicle Load Condition	Switch Position
Driver only	0
Driver + 1 passenger (in front seat)	0
Driver + 4 passengers, no cargo	2
Driver + 4 passengers, cargo added	2
Driver + full cargo	3

Turn Signal Control Lever

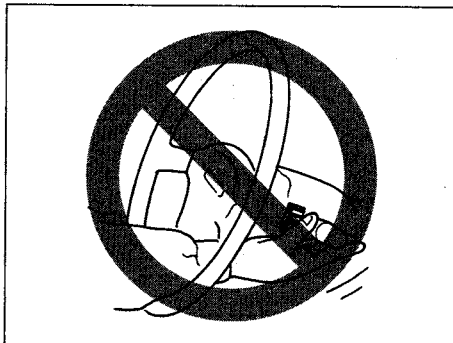

65D611

WARNING

To avoid possible injury, do not operate controls by reaching through the steering wheel.

Turn Signal Operation

With the ignition switch in the "ON" position, move the lever up or down to activate the right or left turn signals.

Normal turn signal

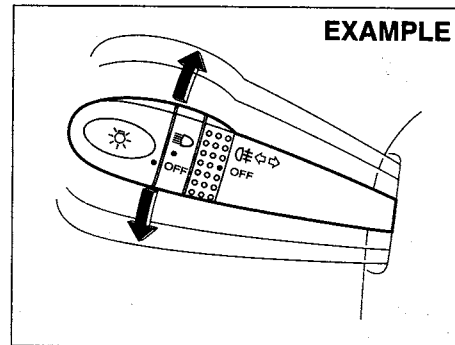

62J032

Move the lever all the way upward or downward to signal. When the turn is completed, the signal will cancel and the lever will return to its normal position.

Lane change signal

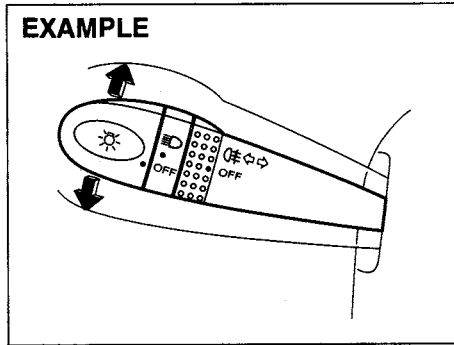

62J033

Some times, such as when changing lanes, the steering wheel is not turned far enough to cancel the turn signal. For convenience, you can flash the turn signal by moving the lever part way and holding it there. The lever will return to its normal position when you release it.

Hazard Warning Switch

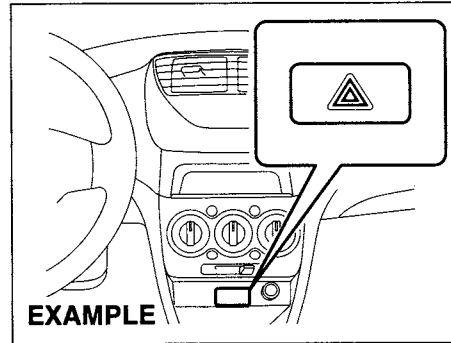

68KM031

Push in the hazard warning switch to activate the hazard warning lights. All turn signal lights and both turn signal indicators will flash simultaneously. To turn off the lights, push the switch again. Use the hazard warning lights to warn other traffic during emergency parking or when your vehicle could otherwise become a traffic hazard.

Windshield Wiper and Washer Lever

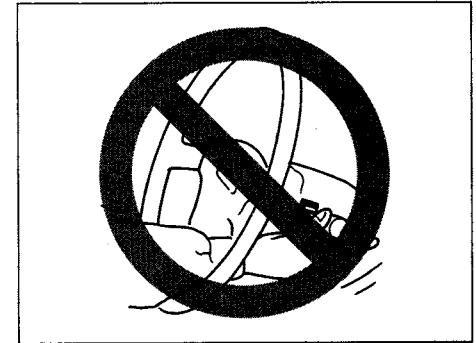

65D611

▲ WARNING

To avoid possible injury, do not operate controls by reaching through the steering wheel.

BEFORE DRIVING

Windshield Wipers

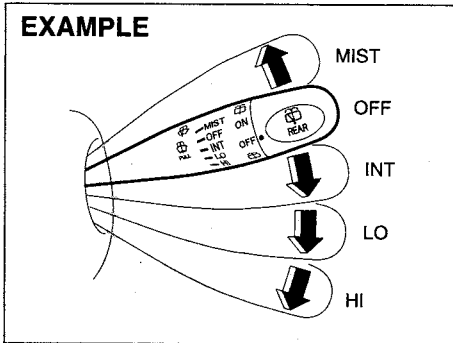

68KM032

To turn the windshield wipers on, move the lever down to one of the three operating positions. In the "INT" position (if equipped), the wipers operate intermittently. The "INT" position is very convenient for driving in mist or light rain. In the "LO" position, the wipers operate at a steady low speed. In the "HI" position, the wipers operate at a steady high speed. To turn off the wipers, move the lever back to the "OFF" position.

Move the lever up and hold it to the "MIST" position, the windshield wipers will turn on continuously at low speed.

Windshield Washer

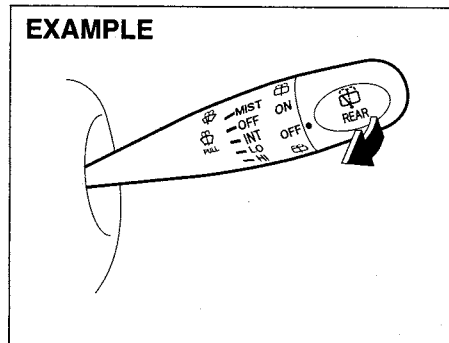

68KM033

To spray windshield washer fluid, pull the lever toward you. The windshield wipers will automatically turn on at low speed if they are not already on and the "INT" position is equipped.

⚠ WARNING

- To prevent windshield icing in cold weather, turn on the defroster to heat the windshield before and during windshield washer use.
- Do not use radiator antifreeze in the windshield washer reservoir. It can severely impair visibility when sprayed on the windshield, and can also damage your vehicle's paint.

CAUTION

To help prevent damage to the windshield wiper and washer system components, you should take the following precautions:

- Do not continue to hold in the lever when there is no windshield washer fluid being sprayed or the washer motor can be damaged.
- Do not attempt to remove dirt from a dry windshield with the wipers or you can damage the windshield and the wiper blades. Always wet the windshield with washer fluid before operating the wipers.
- Clear ice or packed snow from the wiper blades before using the wipers.
- Check the washer fluid level regularly. Check it often when the weather is bad.
- Only fill the washer fluid reservoir 3/4 full during cold weather to allow room for expansion if the temperature falls low enough to freeze the solution.

Rear Window Wiper/Washer Switch (if equipped)

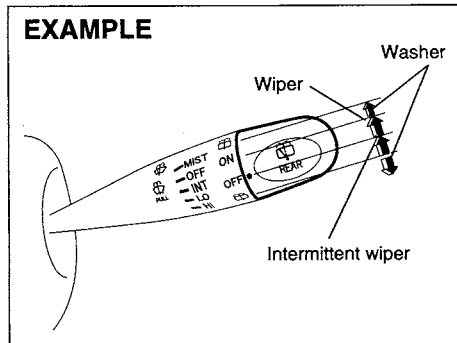

68KM034

To turn the rear wiper on, twist the rear wiper switch on the end of the lever forward to the "ON" position. To turn the rear wiper off, twist the switch rearward to the "OFF" position.

With the rear wiper in the "OFF" position, twist the switch rearward and hold it there to spray window washer fluid.

With the rear wiper in the "ON" position, turn the switch forward and hold it there to spray window washer fluid.

CAUTION

Clear ice or snow from the rear window and rear wiper blade before using the rear wiper. Accumulated ice or snow could prevent the wiper blade from moving, causing damage to the wiper motor.

Tilt Steering Lock Lever (if equipped)

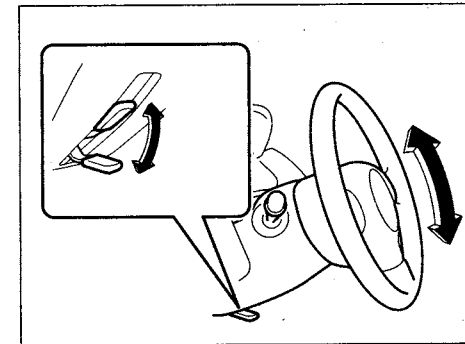

68KM098

The lock lever is located under the steering column. To adjust the steering wheel height:

- 1) Push down the lock lever to unlock the steering column.
- 2) Adjust the steering wheel to the desired height and lock the steering column by pull up the lock lever.
- 3) Try moving the steering wheel up and down to make sure it is securely locked in position.

WARNING

Never attempt to adjust the steering wheel height while the vehicle is moving or you could lose control of the vehicle.

Horn

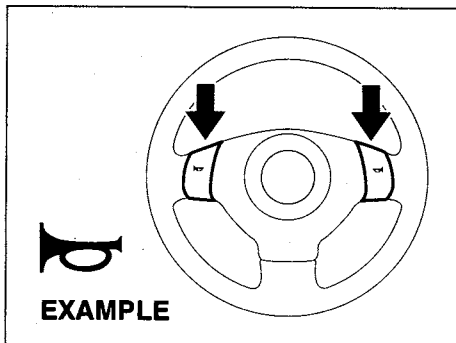

Press the horn button of the steering wheel to sound the horn. The horn will sound with the ignition switch in any position.

Heater Rear Window Switch (if equipped)

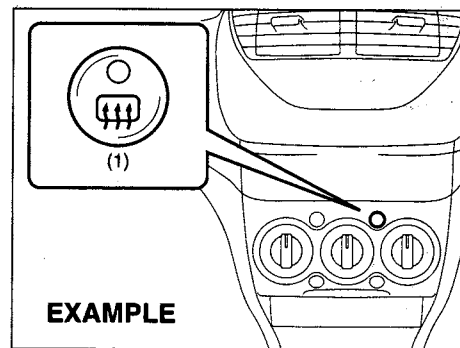

When the rear window is misted, push this switch (1) to clear the window.

An indicator light will be lit when the defogger is on. The defogger will work only when the engine is running. To turn off the defogger, push the switch again.

CAUTION

The heated rear window uses a large amount of electricity. Be sure to turn off after the window has become clear.

Note :

- The defogger will work only when the engine is running.
- The defogger will automatically turn off after the defogger remains on for 15 minutes to prevent discharging of the battery.

MEMO

OPERATING YOUR VEHICLE

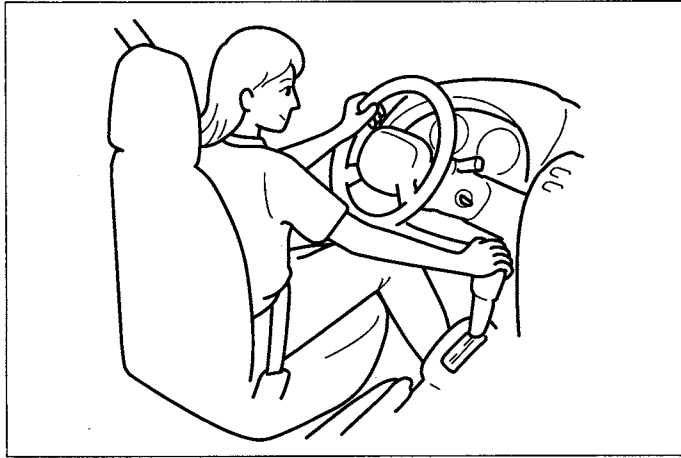

60G408

Exhaust Gas Warning	3-1
Daily Inspection Checklist	3-1
Engine Oil Consumption	3-2
Ignition Switch	3-3
Parking Brake Lever	3-5
Pedal	3-6
Starting the Engine	3-7
Using the Transaxle	3-8
Braking	3-11
Electronic Stability Program (ESP®) (if equipped)	3-14

Exhaust Gas Warning

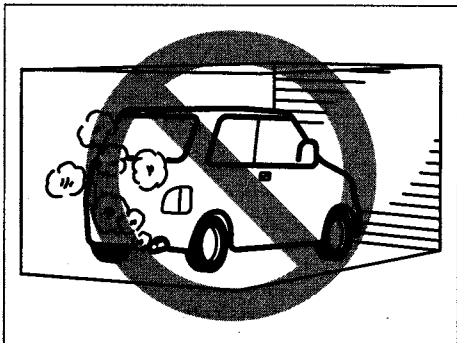

52D334

⚠ WARNING

Avoid breathing exhaust gases. Exhaust gases contain carbon monoxide, a potentially lethal gas that is colorless and odorless. Since carbon monoxide is difficult to detect by itself, be sure to take the following precautions to help prevent carbon monoxide from entering your vehicle.

- Do not leave the engine running in garages or other confined areas.

(Continued)

⚠ WARNING

(Continued)

- Do not park with the engine running for a long period of time, even in an open area. If it is necessary to sit for a short time in a parked vehicle with the engine running, make sure the air intake selector is set to "FRESH AIR" and the fan is at high speed.
- Avoid operating the vehicle with the tailgate or trunk open. If it is necessary to operate the vehicle with the tailgate or trunk open, make sure the sunroof (if equipped) and all windows are closed, and the blower is at high speed with the air intake selector set to "FRESH AIR".
- To allow proper operation of your vehicle's ventilation system, keep the air inlet grille in front of the windshield clear of snow, leaves, or other obstructions at all times.
- Keep the exhaust tailpipe area clear of snow and other material to help reduce the buildup of exhaust gases under the vehicle. This is particularly important when parked in blizzard conditions.
- Have the exhaust system inspected periodically for damage and leaks. Any damage or leaks should be repaired immediately.

Daily Inspection Checklist

Before Driving

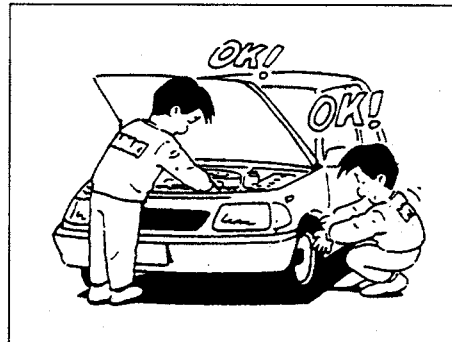

60A187S

- 1) Make sure that windows, mirrors, lights, and reflectors are clean and unobstructed.
- 2) Visually check the tires for the following points:
 - the depth of the tread groove
 - abnormal wear, cracks and damage
 - loose wheel nuts
 - existence of foreign material such as nails, stones, etc.

Refer to "Tires" in "INSPECTION AND MAINTENANCE" section for details.

- 3) Look for fluid and oil leaks.

NOTE:

It is normal for water to drip from the air conditioning system after use.

- 4) Make sure the hood is fully closed and latched.
- 5) Check the headlights, turn signal lights, brake lights and horn for proper operation.
- 6) Adjust the seat and head restraint (if equipped).
- 7) Check the brake pedal and the parking brake lever.
- 8) Adjust the mirrors.
- 9) Make sure that you and all passengers have properly fastened your seat belts.
- 10) Make sure that all warning lights come on as the key is turned to the "ON" position.
- 11) Check all gauges.
- 12) Make sure that the BRAKE SYSTEM WARNING light turns off when the parking brake is released.

Once a week, or each time you fill your fuel tank, perform the following under-hood checks:

- 1) Engine oil level
- 2) Coolant level
- 3) Brake fluid level
- 4) Windshield washer fluid level
- 5) Battery solution level
- 6) Hood latch operation

Pull the hood release handle inside the vehicle. Make sure that you cannot open the hood all the way without releasing the secondary latch. Be sure to close the hood securely after checking for proper latch operation. See "All

latches, hinges & locks" of "CHASSIS AND BODY" in the "Periodic Maintenance Schedule" in the "INSPECTION AND MAINTENANCE" section for lubrication schedule.

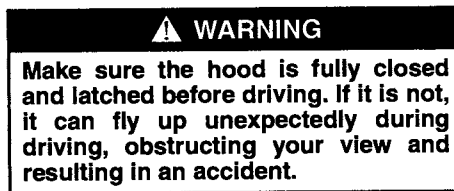

Once a month, or each time you fill your fuel tank, check the tire pressure using a tire pressure gauge. Also check the tire pressure of the spare tire.

Engine Oil Consumption

It is normal for the engine to consume some engine oil during normal vehicle operation.

The amount of engine oil consumed depends on the viscosity of the oil, the quality of the oil and the conditions the vehicle is driven under.

More oil is consumed during high-speed driving and when there is frequent acceleration and deceleration. Under high loads, your engine also will consume more oil.

A new engine also consumes more oil, since its pistons, piston rings and cylinder walls have not yet become conditioned. New engines reach the normal level of oil consumption only after approximately 5000 km (3000 miles) driving.

Oil consumption:
Max. 1.0 L per 1000 km
(1 Qt. per 600 miles)

When judging the amount of oil consumption, note that the oil may become diluted and make it difficult to accurately judge the true oil level.

As an example, if a vehicle is used for repeated short trips, and consumes a normal amount of oil, the dipstick may not show any drop in the oil level at all, even after 1000 km (600 miles) or more of driving. This is because the oil is gradually becoming diluted with fuel or moisture,

OPERATING YOUR VEHICLE

making it appear that the oil level has not changed.

You should also be aware that the diluting ingredients evaporate out when the vehicle is subsequently driven at high speeds, such as on an expressway, making it appear that oil is excessively consumed after high-speed driving.

Ignition Switch

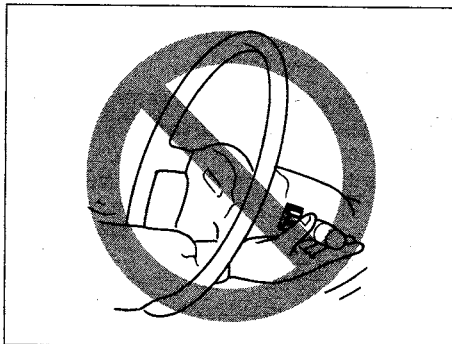

65D611

WARNING

To avoid possible injury, do not operate controls by reaching through the steering wheel.

EXAMPLE

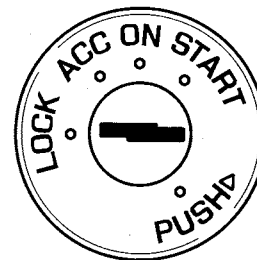

52KM052

The ignition switch has the following four positions:

LOCK

This is the normal parking position. It is the only position in which the key can be removed.

Manual Transaxle

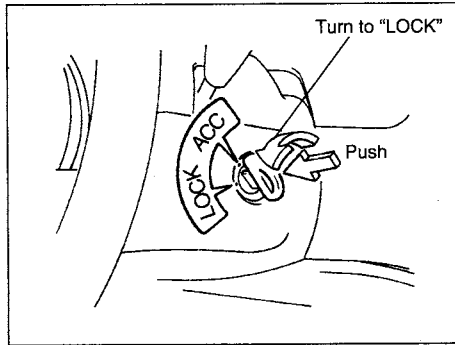

60G033

- **Manual Transaxle**

You must push in the key to turn it to the "LOCK" position. It locks the ignition, and prevents normal use of the steering wheel after the key is removed.

- **Automatic Transaxle Vehicles**

The gearshift lever must be in the "p" (Park) position to turn the key to the 'Lock' position. It locks the ignition and prevents normal use of the steering wheel and gearshift lever.

To release the steering lock, insert the key and turn it clockwise to one of the other positions. If you have trouble turning the key to unlock the steering, try turning the steering wheel slightly to the right or left while turning the key.

ACC

Accessories such as the radio can operate, but the engine is off.

ON

This is the normal operating position. All electrical systems are on.

START

This is the position for starting the engine using the starter motor. The key should be released from this position as soon as the engine starts.

IGNITION KEY REMINDER (IF EQUIPPED)

A buzzer sounds intermittently to remind you to remove the ignition key if it is in the ignition switch when the drivers door is opened.

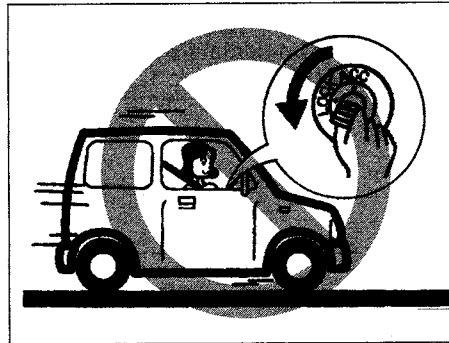

81A297S

⚠ WARNING

- Never remove the ignition key while the vehicle is moving. The steering wheel will lock and you will not be able to steer the vehicle.
- Always remove the ignition key when leaving the vehicle even only for a a short time. Also do not leave children alone in a parked vehicle. Unattended children could cause accidental movement of the vehicle or could tamper with power windows or power sunroof. They also could suffer from heat stroke in warm or hot weather. These could result in severe injury or even death.

CAUTION

- Do not use the starter motor for more than 15 seconds at a time. If the engine does not start, wait 15 seconds before trying again. If the engine does not start after several attempts, check the fuel and ignition systems or consult your SUZUKI dealer.
- Do not leave the ignition switch in the "ON" position if the engine is not running as the battery will discharge.

Parking Brake Lever

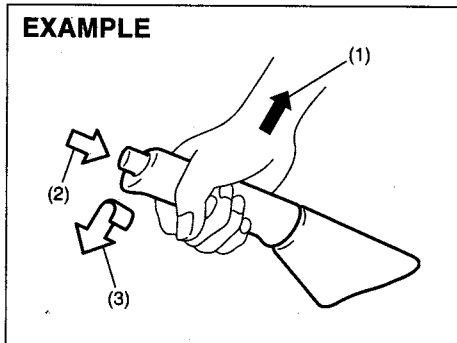

- (1) To set
- (2) To release
- (3) To release

The parking brake lever is located between the seats. To set the parking brake, hold the brake pedal down and pull the parking brake lever all the way up. To release the parking brake, hold the brake pedal down, pull up slightly on the parking brake lever, push the button on the end of the lever with your thumb, and lower the lever to its original position.

For automatic transaxle vehicles, always set the parking brake before moving the gearshift lever to the "P" (PARK) position. If you park on an incline and shift into "P" before setting the parking brake, the weight of the vehicle may make it difficult to shift out of "P" when you are ready to drive the vehicle.

When preparing to drive the vehicle, move the gearshift lever out of the "P" position before releasing the parking brake.

⚠ WARNING

- **Never drive your vehicle with the parking brake on: rear brake effectiveness can be reduced from overheating, brake life may be shortened, or permanent brake damage may result.**
- **If the parking brake does not hold the vehicle securely or does not fully release, have your vehicle inspected immediately by an authorized SUZUKI dealer.**

⚠ WARNING

Always set the parking brake fully before leaving your vehicle or it may move, causing injury or damage. When parking, make sure the gearshift lever for manual transaxle vehicles is in 1st gear or "R" (Reverse) and the gearshift lever for automatic transaxle vehicles is in "P" (Park). Remember, even though the transaxle is in gear or in Park, you must set the parking brake fully.

⚠ WARNING

When parking the vehicle in extremely cold weather, the following procedure should be used:

- 1) Set the parking brake.
- 2) Manual transaxle-turn off the engine then shift into reverse or first gear.
Automatic transaxle-shift into "p" (Park) and turn off the engine.
- 3) With the engine off, get out of the vehicle and put chocks under the wheels.
- 4) Release the parking brake.
When you return to your vehicle, you must remember to first set the parking brake, then remove the wheel chocks.

Pedal

Manual transaxle

EXAMPLE

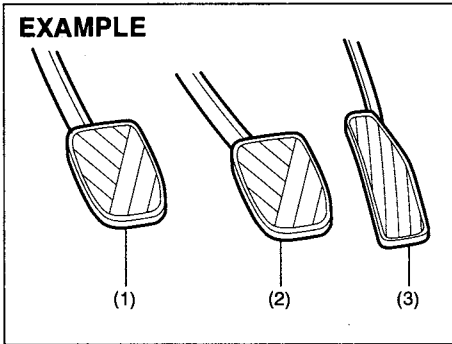

63J182

Automatic transaxle

EXAMPLE

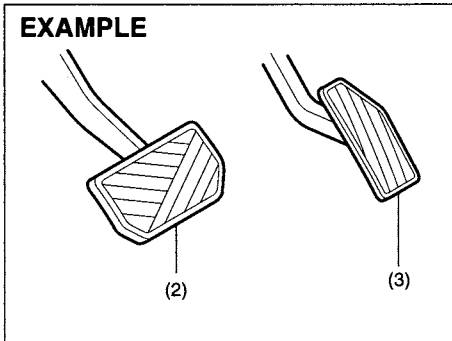

64J083

**Clutch Pedal (1)
(For manual transaxle)**

The clutch pedal is used to disengage the drive to the wheels when starting the engine, stopping, or shifting the gearshift lever. Depressing the pedal disengages the clutch.

CAUTION

Do not drive with your foot resting on the clutch pedal. It could result in excessive clutch wear, clutch damage, or unexpected loss of engine braking.

Brake Pedal (2)

Your SUZUKI vehicle is equipped with front disc brakes and rear drum brakes. Depressing the brake pedal applies both sets of brakes.

You may hear occasional brake squeal when you apply the brakes. This is a normal condition caused by environmental factors such as cold, wet, snow, etc.

⚠ WARNING

If brake squeal is excessive and occurs each time the brakes are applied, you should have the brakes checked by your SUZUKI dealer.

⚠ WARNING

Do not "ride" the brakes by applying them continuously or resting your foot on the pedal. This will result in overheating of the brakes which could cause unpredictable braking action, longer stopping distances, or permanent brake damage.

Accelerator Pedal (3)

This pedal controls the speed of the engine. Depressing the accelerator pedal increases power output and speed.

Starting the Engine

Before Starting the Engine

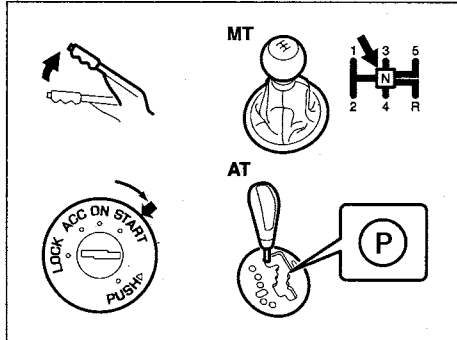

68KM036

- 1) Make sure the parking brake is set fully.
- 2) Manual transaxle – Shift into “N” (Neutral) and depress the clutch pedal all the way to the floor. Hold the clutch pedal while starting the engine.
Automatic transaxle – If the gearshift lever is not in “P” (Park) position, shift into “P” (Park). (if you need to re-start the engine while the vehicle is moving, shift into “N”.)

NOTE:

Automatic transaxle vehicles have a starter interlock device which is designed to keep the starter from operating if the transaxle is in any of the drive positions.

⚠ WARNING

Make sure that the parking brake is set fully and the transaxle is in Neutral before attempting to start the engine.

Starting a Cold and Warm Engine

With your foot off the accelerator pedal, crank the engine by turning the ignition key to “START”. Release the key when the engine starts.

CAUTION

- Stop turning the starter immediately after the engine has started or the starter system can be damaged.
- Do not crank the engine for more than 15 seconds at a time. If the engine doesn't start on the first try, wait about 15 seconds before trying again.

If the engine does not start after 15 seconds of cranking, wait about 15 seconds, then press down the accelerator pedal to 1/3 of its travel and try cranking the engine again. Release the key and accelerator pedal when the engine starts.

If the engine still does not start, try holding the accelerator pedal all the way to the floor while cranking. This should clear the engine if it is flooded.

Using the Transaxle

Manual Transaxle

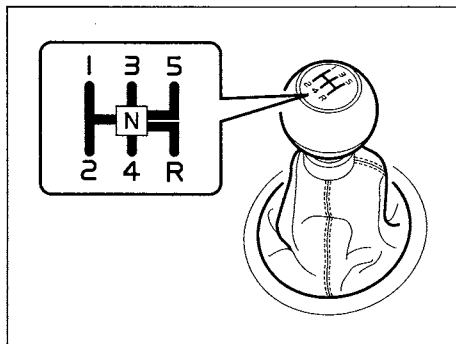

68KH032

Starting off

To start off, depress the clutch pedal all the way to the floor and shift into 1st gear. After releasing the parking brake, gradually release the clutch. When you hear a change in the engine's sound, slowly press the accelerator while continuing to gradually release the clutch.

Shifting

All forward gears are synchronized, which provides for quiet, and easy shifting. Always push in the clutch pedal fully before shifting gears.

Downshifting maximum allowable speeds

For K10B engine

Downshifting	Km/h (mph)
2nd to 1st	50 (31)
3rd to 2nd	90 (56)
4th to 3rd	135 (84)
5th to 4th	180 (112)*

*NOTE:

You may not accelerate to the maximum allowable speed because of the driving situation and/or the vehicle condition.

CAUTION

When downshifting to a lower gear, make sure not to operate with the speed faster than the maximum allowable speeds for the next lower gear, or severe engine damage can result.

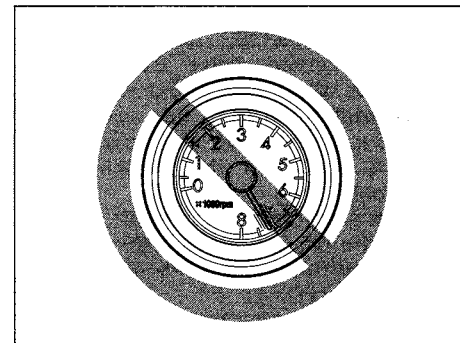

68KH033

Keep the engine speed so it does not get into the red zone of tachometer.

⚠ WARNING

- Reduce your speed and downshift to a lower gear before going down a long or steep hill. A lower gear will allow the engine to provide braking. Avoid riding the brakes or they may overheat, resulting in brake failure.
- When driving on slippery roads, be sure to slow down before downshifting. Excessive and or sudden changes in engine speed may cause loss of traction, which could cause you to lose control.
- Make sure that the vehicle is completely stationary before you shift into reverse.

CAUTION

- To help avoid clutch damage, do not use the clutch pedal as a foot-rest while driving or use the clutch to keep the vehicle stationary on a slope. Depress the clutch fully when shifting.
- When shifting or starting off, do not race the engine. Racing the engine can shorten engine life and affect smooth shifting.

4-Speed Automatic Transaxle

EXAMPLE

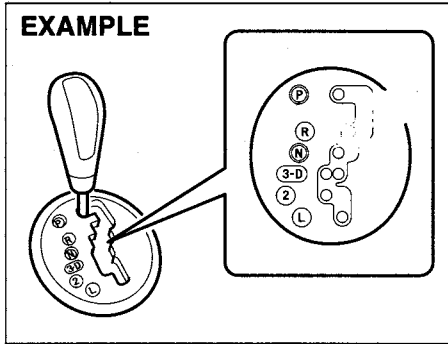

77J021

Gearshift lever

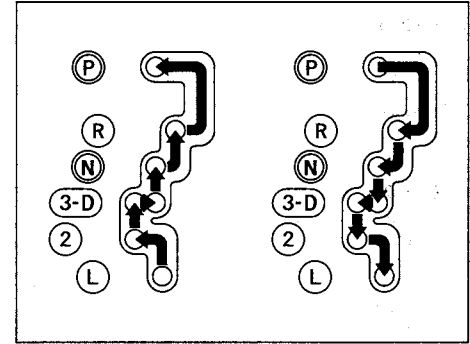

77J028

⚠ WARNING

Always depress the brake pedal before shifting from "P" (Park) (or "N" (Neutral) if the vehicle is stationary) to a forward or reverse gear, to help prevent the vehicle from moving unexpectedly when you shift.

Use the gearshift lever positions as described below:

P (Park)

Use this position to lock the transaxle when the vehicle is parked or when starting the engine. Shift into Park only when the vehicle is completely stationary.

R (Reverse)

Use this position to reverse the vehicle from stop. Make sure that vehicle is completely stationary before shifting into Reverse.

N (Neutral)

Use this position for starting the engine if the engine stalls and you need to restart it while the vehicle is moving. You may also shift into Neutral and depress the brake pedal to hold the vehicle stationary during idling.

D (Drive)

Use this position for all normal driving.

With the gearshift lever in "D" range you can get an automatic downshift by pressing the accelerator pedal. The higher the vehicle speed is, the more you need to press the accelerator pedal to get a downshift.

3 (Low 3)

Use this position for driving on moderate uphill and downhill gradients. The engine braking effect on moderate downhills can be used in this position. The transaxle shifts up only to 3rd gear.

2 (Low 2)

Use this position to provide extra power when climbing hills, or to provide engine braking when going down hills.

L (Low 1)

Use this position to provide maximum power when climbing steep hills or driving

through deep snow or mud, or to provide maximum engine braking when going down steep hills.

NOTE:

If you move the gearshift lever to a lower gear while driving faster than the maximum allowable speed for the lower gear, the transaxle will not actually downshift until your speed drops below the maximum speed for the lower gear.

CAUTION

Be sure to take the following precautions to help avoid damage to the automatic transaxle:

- **Make sure that the vehicle is completely stationary before shifting into "P" or "R".**
- **Do not shift from "P" or "N" to "R", "D", "3", "2", or "L" when the engine is running above idle speed.**
- **Do not rev the engine with the transaxle in a drive position ("R", "D", "3", "2", or "L") and the front wheels not moving.**
- **Do not use the accelerator to hold the vehicle on a hill. Use the vehicle's brakes.**

If You Cannot Shift Automatic Transaxle Gearshift Lever Out of "P" (PARK)

Left Hand Drive Vehicle

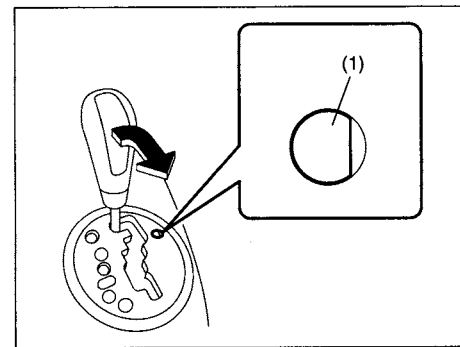

68KM037

Vehicles with an automatic transaxle have an electrically operated park-lock feature. If the vehicle's battery is discharged, or there is some other electrical failure, the automatic transaxle cannot be shifted out of Park in the normal way. Jump starting may correct the condition. If not, follow the procedure described below. This procedure will permit shifting the transaxle out of Park.

- 1) Be sure the parking brake is firmly applied.
- 2) If the engine is running, stop the engine.

OPERATING YOUR VEHICLE

- 3) Make sure the key is in the "ON" or "ACC" position.
- 4) Remove the cover (1) over the button.
- 5) With pushing the release button by the key or the flat end rod, shift the gearshift lever to the desired position.

This procedure is for emergency use only. If repeated use of this procedure is necessary, or the procedure does not work as described, take the vehicle to your dealer for repair.

Right Hand Drive Vehicle

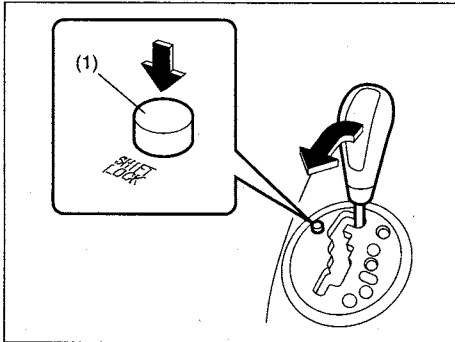

68KM038

Vehicles with an automatic transaxle have an electrically operated park-lock feature. If the vehicle's battery is discharged, or there is some other electrical failure, the automatic transaxle cannot be shifted out of Park in the normal way. Jump starting may correct the condition. If not, follow the procedure described below. This proce-

cedure will permit shifting the transaxle out of Park.

- 1) Be sure the parking brake is firmly applied.
- 2) If the engine is running, stop the engine.
- 3) Make sure the key is in the "ON" or "ACC" position.
- 4) With pushing the release button (1), shift the gearshift lever to the desired position.

This procedure is for emergency use only. If repeated use of this procedure is necessary, or the procedure does not work as described, take the vehicle to your dealer for repair.

Braking

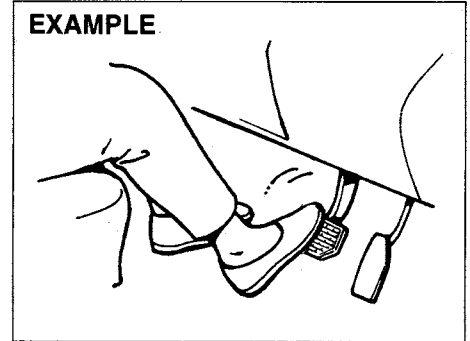

60G165S

The distance needed to bring any vehicle to a halt increases with the speed of the vehicle. The braking distance needed, for example, at 60 km/h (37 mph) will be approximately 4 times greater than the braking distance needed at 30 km/h (19 mph). Start to brake the vehicle when there is plenty of distance between your vehicle and the stopping point, and slow down gradually.

⚠ WARNING

If water gets into the brake drums, brake performance may become poor and unpredictable.

After driving through water or washing the underside of the vehicle, test the brakes while driving at a slow speed to see if they have maintained their normal effectiveness. If the brakes are less effective than normal, dry them by repeatedly applying the brakes while driving slowly until the brakes have regained their normal effectiveness.

Power-Assisted Brakes

Your vehicle has power assisted brakes. If power assistance is lost due to a stalled engine or other failures, the system is still fully operational on reserve power and you can bring the vehicle to a complete stop by pressing the brake pedal once and holding it down. The reserve power is partly used up when you depress the brake pedal and reduces each time the pedal is pressed. Apply smooth and even pressure to the pedal. Do not pump the pedal.

⚠ WARNING

Even without reserve power in the brake system, you can still stop the vehicle by pressing the brake pedal harder than normally required. However, the stopping distance may be longer.

Brake Assist System (if equipped)

When you slam the brakes on, the brake assist system judges as an emergency stop and provides more powerful braking for a driver who cannot hold down the brake pedal firmly.

NOTE:

If you quickly and forcefully depress the brakes, you may hear a clicking sound in the brake pedal. This is normal and indicates that the brake assist system is activated properly.

**Anti-Lock Brake System (ABS)
(if equipped)**

ABS will help you avoid skidding by electronically controlling braking pressure. It will also help you maintain steering control when braking on slippery surfaces or when braking hard.

The ABS works automatically, so you do not need any special braking technique. Just push the brake pedal down without pumping. The ABS will operate whenever it senses that the wheels are locking up. You may feel the brake pedal moves a little while the ABS is operating.

NOTE:

The ABS will not work if vehicle speed is under about 10 km/h (6 mph).

▲ WARNING

- On some types of loose surfaces (such as gravel, snow-covered roads, etc.) the stopping distance required for an ABS-equipped vehicle may be slightly greater than for a comparable vehicle with a conventional brake system. With a conventional brake system, skidding tires are able to “plow” the gravel or snow layer, shortening the stopping distance, ABS minimizes this resistance effect. Allow for extra stopping distance when driving on loose surfaces.
- On regular paved roads, some drivers may be able to obtain slightly shorter stopping distances with conventional brake systems than with ABS.
- In both of the above conditions, ABS will still offer the advantage of helping you maintain directional control. However, remember that ABS will not compensate for bad road or weather conditions or poor driver judgment. Use good judgment and do not drive faster than conditions will safely allow.



(1)



(2)

52KM059

- (1) ABS warning light
- (2) Brake system warning light

▲ WARNING

- If the ABS warning light (1) on the instrument panel comes on and stays on while driving, there may be a problem with the ABS system. Ask your SUZUKI dealer to inspect the ABS system immediately. If the ABS system becomes inoperative, the brake system will function as an ordinary brake system that has no ABS.

(Continued)

▲ WARNING

(Continued)

- If the ABS warning light (1) and the Brake system warning light (2) on the instrument panel simultaneously stays on or comes on when driving, both anti-lock function and rear brake force control function (proportioning valve function) of the ABS system may have failed. If so, the rear wheels may easily skid or the vehicle can even spin in the worst case when braking on a slippery road or when hard braking even on a dry paved road. Ask your SUZUKI dealer to inspect the ABS system immediately. Drive carefully, avoiding hard braking as much as possible.

How the ABS Works

A computer continuously monitors wheel speed. The computer compares the changes in wheel speed when braking. If the wheels slow suddenly, indicating a skidding situation, the computer will change braking pressure several times each second to prevent the wheels from locking. When you start your vehicle after a stop you may hear a momentary motor noise as the system checks itself.

WARNING

The ABS may not work properly if tires or wheels other than those specified in the owner's manual are used. This is because the ABS works by comparing changes in wheel speed. When replacing tires or wheels, use only the size and type specified in this owner's manual.

Electronic Stability Program (ESP®) (if equipped)

ESP® is a registered trademark of Daimler AG.

The Electronic Stability Program (ESP®) helps to control the vehicle during cornering if front wheels or rear wheels skid. It also assists you in maintaining traction while accelerating on loose or slippery road surfaces. It does this by regulating the engine's output, and by selectively applying the brakes. In addition, ESP® helps to avoid skidding by controlling braking pressure.

WARNING

The ESP® cannot enhance the vehicle's driving stability in all situations and does not control your vehicle's entire braking system. The ESP® cannot prevent accidents, including those resulting from excessive speed in turns, or hydroplaning. Only a safe and attentive driver can prevent accidents. The capabilities of an ESP®-equipped vehicle must never be used as a substitute for careful driving.

The ESP® has the following three systems:

Stability Control System

The vehicle stability control system helps provide integrated control of systems such as anti-lock brakes, traction control, engine control, etc. This system automatically controls the brakes and engine to help prevent the vehicle from skidding when cornering on a slippery road surface or when turning the steering wheel abruptly.

Traction Control System

The traction control system automatically helps prevent the spinning of wheels when the vehicle is started or accelerated on slippery road surfaces. The system operates only if it senses that some of the wheels are spinning or beginning to lose traction. When this happens, the system operates the front or rear brakes and reduces engine power to limit wheel spin.

NOTE:

You may hear a clicking sound in the engine compartment for a few seconds when you start the engine or just after the vehicle begins to move. This means that the above systems are in the self-check mode. This sound does not indicate a malfunction.

Anti-Lock Braking System (ABS)

ABS will help you avoid skidding by electronically controlling braking pressure. It will also help you maintain steering control when braking on slippery surfaces or when braking hard. The ABS works automatically, so you do not have to use any special braking technique. Just push the brake pedal down without pumping. The ABS will operate whenever it senses that wheels are locking up. You may feel the brake pedal pulsate while the ABS is operating. (For more information on ABS, see "Braking" in this section.)

NOTE:

If the ABS system is activated, you may hear a clunking noise and/or feel pulsating in the brake pedal. This is normal and indicates that the brake fluid pressure is being controlled properly.

⚠ WARNING

- The ESP[®] may not work properly if tires or wheels other than those specified in the Owner's Manual are used. When replacing tires or wheels, use only the size and type specified in this Owner's Manual.
- The ESP[®] may not work properly if tires are not inflated to the recommended tire inflation pressure.
- The ESP[®] may not work properly if tires are fitted with tire chains.
- The ESP[®] may not work properly if the tires are excessively worn. Be sure to replace tires when the tread wear indicators in the grooves appear on the tread surface.
- The ESP[®] is not a substitute for winter tires or tire chains on a snow covered road.

⚠ WARNING

- The ESP[®] may not work properly if engine related parts such as the muffler are not equivalent to standard equipment or are extremely deteriorated.
- Do not modify the vehicle's suspension since the ESP[®] may not operate correctly.

The ESP[®] indicator lights are described below:

SLIP Indicator Light



52KM133

When one of the ESP[®] systems other than ABS is activated, the SLIP indicator light in the instrument cluster blinks 5 times per second.

CAUTION

If the SLIP indicator light comes on and stays on while driving, there may be a malfunction of the ESP[®] systems (other than ABS). You should have the systems inspected by an authorized SUZUKI dealer.

NOTE:

When the SLIP indicator light comes on and stays on while driving, indicating a malfunction of the ESP[®] systems (other than ABS), the brake system will function as an ordinary ABS with no additional ESP[®] functions.

NOTE:

When you disconnect and re-connect the battery, ESP® system functions other than ABS will be deactivated and the slip indicator light will blink 1 time per second. In this case, use the following procedure to re-activate the ESP® systems:

- 1) Drive your vehicle straight ahead without tire slippage at a speed greater than approximately 15 km/h (9 mph) for a few seconds.
- 2) The slip indicator light will go out and the ESP® systems (other than ABS) will be re-activated.

It may take more than few seconds before the slip indicator light goes out depending on the road surface condition.

“ESP” Warning Light



66J031

When the ESP® systems (other than ABS) have a system malfunction, the “ESP” warning light in the instrument cluster comes on.

CAUTION
<p>If the “ESP” warning light comes on, or stays on while driving, there may be a malfunction of the ESP® systems (other than ABS). You should have the systems inspected by an authorized SUZUKI dealer.</p>

NOTE:

When the “ESP” warning light comes on, or stays on while driving, indicating a malfunction of the ESP® systems (other than ABS), the brake system will function as an ordinary ABS that has no additional ESP® functions.

“TCSS OFF” Indicator Light

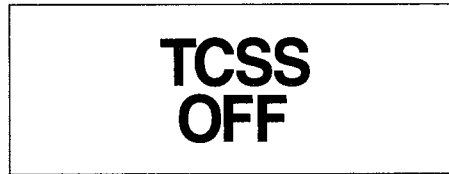

52KM132

TCSS means the traction control system which is one of three systems included in ESP®, stability control system, traction control system, and anti-lock braking system.

You should turn the traction control system on during your ordinary driving, so that you have the benefits of all of the ESP® systems.

It may be required to turn the traction control system off if your vehicle is stuck in sand, mud, or snow, where wheel spin is necessary.

“TCSS OFF” switch

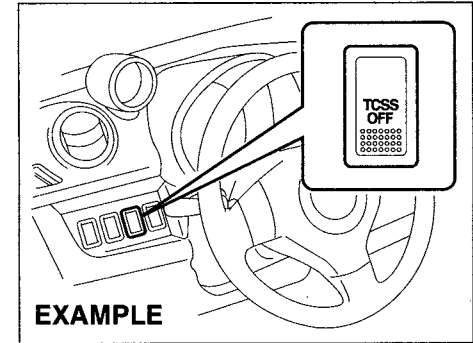

68KM039

When the “TCSS OFF” switch is pushed to turn off the traction control system, the “TCSS OFF” indicator light in the instrument cluster comes on.

When you have turned the traction control system off, make sure to turn them back on before resuming ordinary driving.

When you push the “TCSS OFF” switch again, the “TCSS OFF” indicator light will go out and all of the ESP® systems will be activated.

OPERATING YOUR VEHICLE

NOTE:

If the traction control system operates continuously, such as when driving on slippery roads, the traction control system may be canceled temporarily to avoid overheating the brake pads, and the "TCSS OFF" indicator light will come on. After a short period of time, the traction control system will turn on automatically and the "TCSS OFF" indicator light will go out.

**ABS Warning Light / Brake System
Warning Light**

See "Braking" in this section.

DRIVING TIPS

Running-in	4-1
Catalytic Converter	4-1
Improving Fuel Economy	4-2
Highway Driving	4-3
Driving on Hills	4-3
Driving on Slippery Roads	4-4

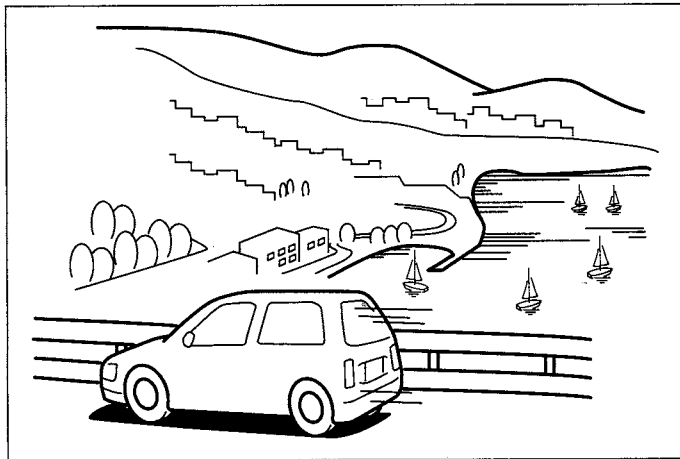

60G409

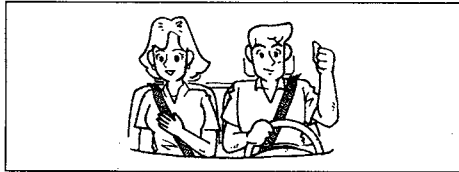

52D078S

▲ WARNING

- **Wear Your Seat Belts at All Times.** Even though air bags are equipped at the front seating positions, the driver and all passengers should be properly restrained at all times, using the seat belts provided. Refer to the "Seat Belts and Child Restraint Systems" section for instructions on proper use of the seat belts.
- **Never drive while under the influence of alcohol or other drugs.** Alcohol and drugs can seriously impair your ability to drive safely, greatly increasing the risk of injury to yourself and others. You should also avoid driving when you are tired, sick, irritated, or under stress.

Running-in

CAUTION

The future performance and reliability of the engine depends on the care and restraint exercised during its early life. It is especially important to observe the following precautions during the initial 960 km (600 miles) of vehicle operation.

- **After starting, do not race the engine.** Warm it up gradually.
- **Avoid prolonged vehicle operation at a constant speed.** Moving parts will break in better if you vary your speed.
- **Start off from a stop slowly.** Avoid full throttle starts.
- **Avoid hard braking, especially during the first 320 km (200 miles) of driving.**
- **Do not drive slowly with the transaxle in a high gear.**
- **Drive the vehicle at moderate engine speeds.**
- **Do not tow a trailer during the first 960 km (600 miles) of vehicle operation.**

Catalytic Converter

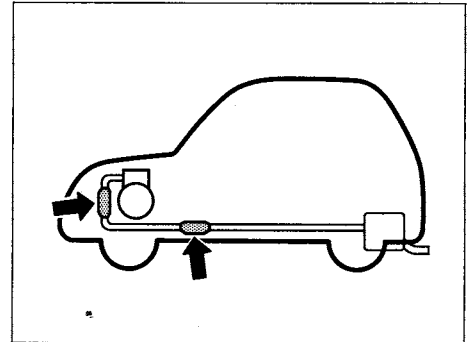

68KM085

The purpose of the catalytic converter is to minimize the amount of harmful pollutants in your vehicle's exhaust. Use of leaded fuel in vehicles equipped with catalytic converters is prohibited, because lead deactivates the pollutant-reducing components of the catalyst system.

The converter is designed to last the life of the vehicle under normal usage and when unleaded fuel is used. No special maintenance is required on the converter. However, it is very important to keep the engine properly tuned. Engine misfiring, which can result from an improperly tuned engine, may cause overheating of the catalyst. This may result in permanent heat damage to the catalyst and other vehicle components.

CAUTION

To minimize the possibility of catalyst or other vehicle damage:

- Maintain the engine in the proper operating condition.
- In the event of an engine malfunction, particularly one involving engine misfire or other apparent loss of performance, have the vehicle serviced promptly.
- Do not turn off the engine or interrupt the ignition when the transaxle is in gear and the vehicle is in motion.
- Do not try to start the engine by pushing or towing the vehicle, or coasting down a hill.
- Do not idle the engine with any spark plug wires disconnected or removed, such as during diagnostic testing.
- Do not idle the vehicle for prolonged periods if idling seems rough or there are other malfunctions.
- Do not allow the fuel tank to get near the empty level.

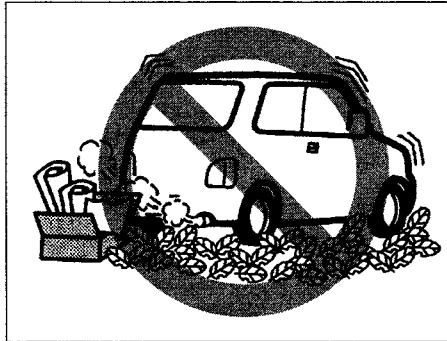

54G584S

⚠ WARNING

Be careful where you park and drive; the catalytic converter and other exhaust components can get very hot. As with any vehicle, do not park or operate this vehicle in areas where combustible materials such as dry grass or leaves can come in contact with a hot exhaust system.

Improving Fuel Economy

The following instructions will help you improve fuel economy.

Avoid excessive idling

If you are to wait for more than a minute while you are parked, stop the engine and start it again later. When warming up a cold engine, do not allow the engine to idle or apply full throttle until the engine has reached operating temperature. Allow the engine to warm up by driving.

Avoid "fast" starts

Fast starts away from lights or stop signs will consume fuel unnecessarily and shorten engine life. Start off slowly.

Avoid unnecessary stops

Avoid unnecessary deceleration and stopping. Try to maintain a slow, steady speed whenever possible. Slowing down and then accelerating again uses more fuel.

Keep a steady cruising speed

Keep as constant a speed as road and traffic conditions will permit.

DRIVING TIPS

Keep the air cleaner clean

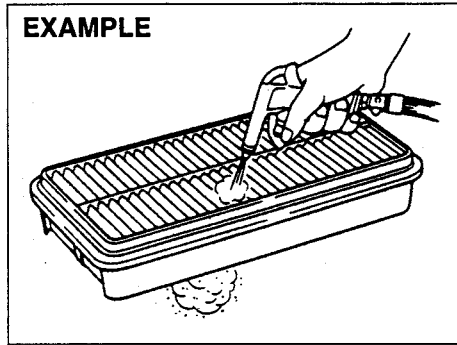

If the air cleaner is clogged with dust, there will be greater intake resistance, resulting in decreased power output and increased fuel consumption.

Keep weight to a minimum

The heavier the load, the more fuel the vehicle consumes. Take out any luggage or cargo when it is not necessary.

Keep tire pressures correct

Underinflation of the tires can waste fuel due to increased running resistance of the tires. Keep your tires inflated to the correct pressure shown on the label on the driver's side door or the driver's door lock pillar.

Highway Driving

When driving at highway speeds, pay attention to the following:

- Stopping distance progressively increases with vehicle speed. Apply the brakes far enough ahead of the stopping point to allow for the extra stopping distance.
- On rainy days, "Hydroplaning" can occur. "Hydroplaning" is the loss of direct contact between the road surface and the vehicle's tires due to a water film forming between them. Steering or braking the vehicle while "Hydroplaning" can be very difficult, and loss of control can occur. Keep speed down when the road surface is wet.
- At high speeds, the vehicle may be affected by side winds. Therefore, reduce speed and be prepared for unexpected buffeting, which can occur at the exits of tunnels, when passing by a cut of a hill, or when being overtaken by large vehicles, etc.

Driving on Hills

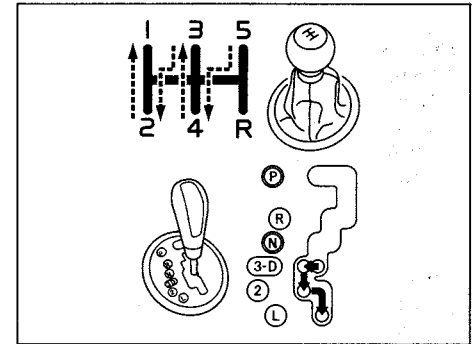

- When climbing steep hills, the car may begin to slow down and show a lack of power. If this happens, you should shift to a lower gear so that the engine will again be operating in its normal power range. Shift rapidly to prevent the car from losing momentum.
- When driving down a hill, the engine should be used for braking by shifting into a lower gear.

⚠ WARNING

Try not to hold the brake pedal down too long or too often while going down a steep or long hill. This could cause the brakes to overheat, resulting in reduced braking efficiency. Failure to take this precaution could result in loss of vehicle control.

CAUTION

When descending a down hill, **NEVER** turn the ignition key to the "OFF" position. Emission control system and automatic transaxle damage may result.

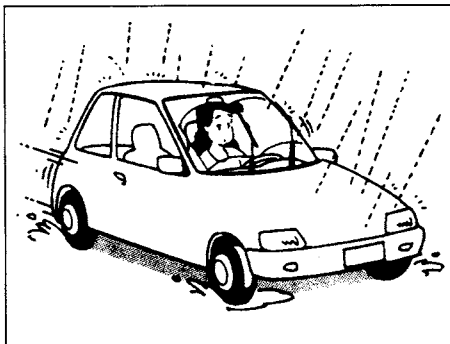
Driving on Slippery Roads.

60G089S

Under wet road conditions you should drive at a lower speed than on dry roads due to possible slippage of tires during braking. When driving on icy, snow-covered, or muddy roads, reduce your speed and avoid sudden acceleration, abrupt braking, or sharp steering movements.

Tire Chains

Tire chains should only be used if they are needed to increase traction or are required by law. Make sure that the chains you use are the correct size for your vehicle's tires. Also make sure that there is enough clearance between the fenders and the chains as installed on the tires.

Install the chains on the front tires tightly, according to the chain manufacturer's instructions. Retighten the chains after driving about 1.0 km (1/2 mile) if necessary. With the chains installed, drive slowly.

CAUTION

- If you hear the chains hitting against the vehicle body while driving, stop and tighten them.
- If your vehicle is equipped with full wheel caps, remove the wheel caps before installing the chains or the wheel caps can be damaged by the chain bands.

If Your Vehicle Gets Stuck

If your vehicle gets stuck in snow, mud, or sand, follow the directions below:

- 1) Shift the transaxle back and forth between a forward range (or first gear for manual transaxle) and reverse. This will create a rocking motion which may give you enough momentum to free the vehicle. Press gently on the accelerator to keep wheel spinning to a minimum wheel rpm. Remove your foot from the accelerator while shifting.
Do not race the engine. Excessive wheel spin will cause the tires to dig deeper, making it more difficult to free the vehicle.
- 2) If your vehicle remains stuck after a few minutes of rocking, get another vehicle to pull your vehicle out.

WARNING

Do not allow anyone to stand near the vehicle when you are rocking it, and do not spin the wheels faster than an indicated 40 km/h (25 mph) on the speedometer. Personal injury and/or vehicle damage may result from spinning the wheels too fast.

CAUTION

Do not continue rocking the vehicle for more than a few minutes. Prolonged rocking can cause engine overheating or transaxle damage.

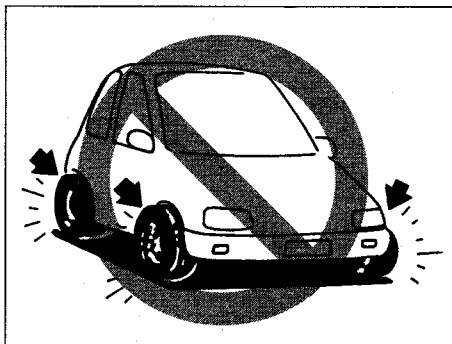

54G638S

WARNING

In addition to following the driving tips in this section, it is important to observe the following precautions.

- Make sure your tires are in good condition and always maintain the specified tire pressure. Refer to "Tires" in the "INSPECTION AND MAINTENANCE" section for details.

(Continued)

WARNING

(Continued)

- Do not use tires other than those specified by SUZUKI. Never use different sizes or types of tires on the front and rear wheels. For information regarding the specified tires, refer to the Tire Information Label located on the driver's door lock pillar.
- Never use oversized tires or special shock absorbers and springs to raise (jack up) your vehicle. This will change the handling characteristics. Oversized tires may also rub against the fender over bumps, causing vehicle damage or tire failure.
- After driving through water, test the brakes while driving at a slow speed to see if they have maintained their normal effectiveness. If the brakes are less effective than normal, dry them by repeatedly applying the brakes while driving slowly until the brakes have regained their normal effectiveness.

OTHER CONTROLS AND EQUIPMENT

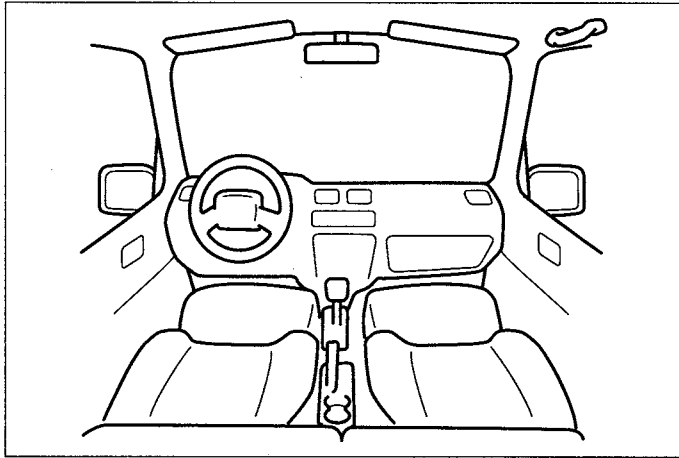

60G407

Heating and Air Conditioning System	5-1
Heating System	5-2
Manual Heating and Air Conditioning System	5-5
Radio Antenna	5-8
Installation of Radio Frequency Transmitters	5-9
Audio Systems	5-9
Fuel Filler Cap	5-30
Engine Hood	5-31
Sun Visor	5-32
Interior Light Switch	5-32
Accessory Socket (if equipped)	5-33
Glove Box	5-33
Cup Holder (if equipped)	5-34
Luggage Area Cover (if equipped)	5-34
Frame Hooks	5-35

OTHER CONTROLS AND EQUIPMENT

Heating and Air Conditioning System

There are various types of heating and air conditioning systems as follows:

- Heating System
- Manual Heating and Air Conditioning System

Air Outlet

EXAMPLE

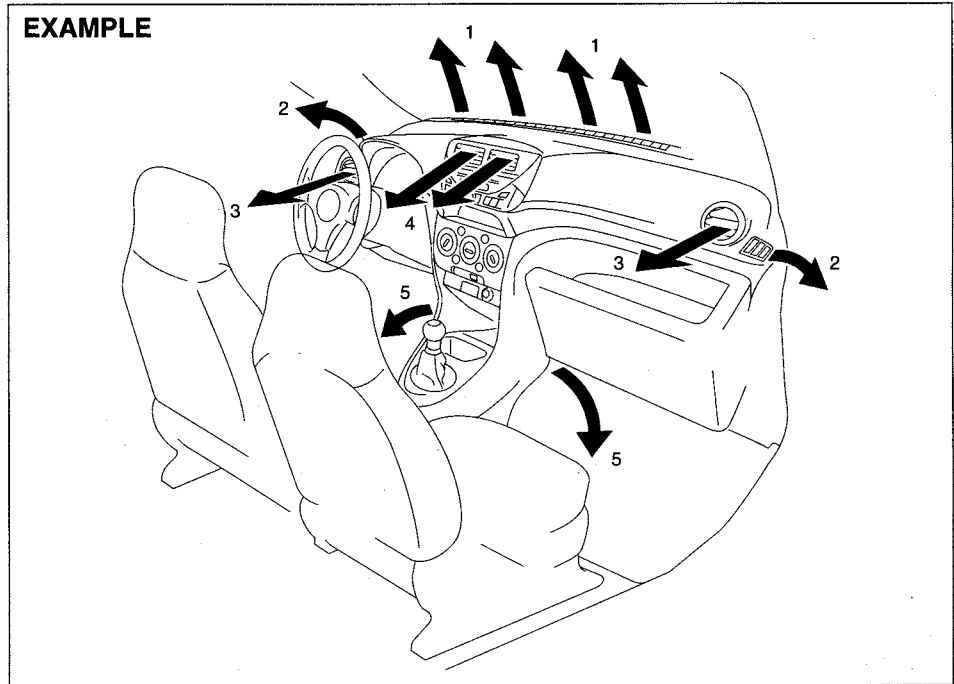

68KM040

1. Windshield defroster outlet
2. Side defroster outlet
3. Side outlet
4. Center outlet
5. Front floor outlet

Side outlet

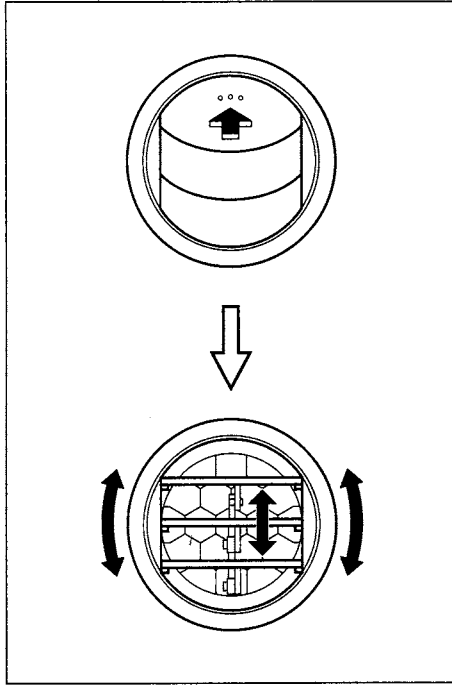

63J045

When "Open", air comes out regardless of the air flow selector position.

Heating System

Description of Controls

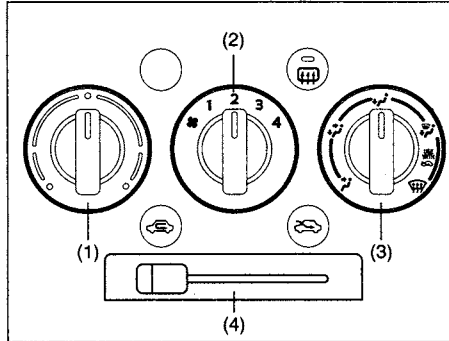

68KM041

Temperature selector (1)

This is used to select the temperature by turning the selector.

Blower speed selector (2)

This is used to turn on the blower and to select blower speed by turning the selector.

Air flow selector (3)

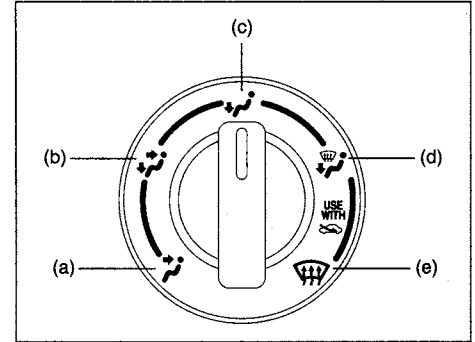

68KH044

This is used to select one of the functions described below.

Ventilation (a)

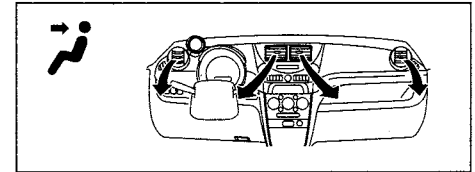

68KM042

Temperature-controlled air comes out of the center and side air outlets.

OTHER CONTROLS AND EQUIPMENT

Bi-level (b)

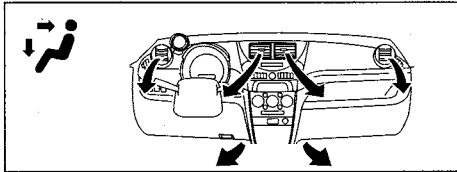

68KM043

Temperature-controlled air comes out of the floor outlets and cooler air comes out of the center and side outlets. When the temperature selector (1) is in the fully COLD position or fully HOT position, however, the air from the floor outlets and the air from the center and side outlets will be the same temperature.

Heat (c)

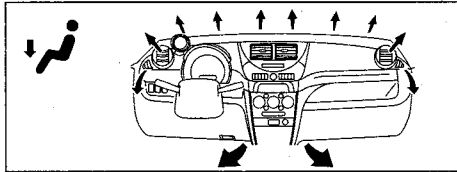

68KM044

Temperature-controlled air comes out of the floor outlets and the side outlets, also comes out of the windshield defroster outlets and also comes slightly out of the side defroster outlets.

Heat & defrost (d)

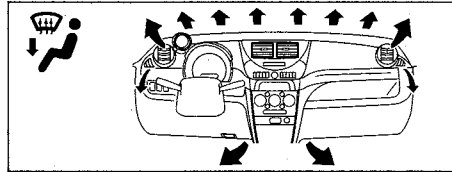

68KM045

Temperature-controlled air comes out of the floor outlets, the windshield defroster outlets, the side defroster outlets and the side outlets.

Defrost (e)

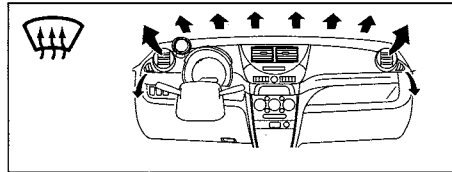

68KM046

Temperature-controlled air comes out of the windshield defroster outlets, the side defroster outlets and the side outlets.

Air intake selector (4)

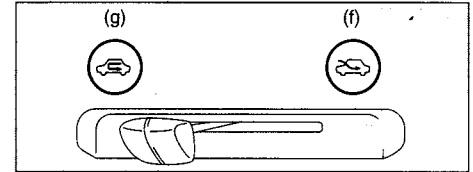

68KH050

This selector is used to select the following modes.

Fresh Air (f)

When this mode is selected by moving the lever to right, outside air is used.

Recirculated Air (g)

When this mode is selected by moving lever to left, outside air is shut out and inside air is recirculated. This mode is suitable when driving through dusty or polluted air such as in a tunnel.

NOTE:

If you select "RECIRCULATED AIR" for an extended period of time, the air in the vehicle can become contaminated. Therefore, you should occasionally select "FRESH AIR".

System Operating Instructions

Natural ventilation

Select "VENTILATION" and "FRESH AIR", the temperature selector to the desired temperature position, and the blower speed selector to "OFF". Fresh air will flow through the vehicle during driving.

Forced ventilation

The control settings are the same as for natural ventilation except you set the blower speed selector to a position other than "OFF".

Normal heating (using outside air)

Select "HEAT" and "FRESH AIR", the temperature selector to the desired temperature position and the blower speed selector to the desired blower speed position. Setting the blower speed selector to a higher blower speed position increases heating efficiency.

Quick heating (using recirculated air)

The control settings are the same as for normal heating except you select "RECIRCULATED AIR". If you use this heating method for an extended period of time, the air in the vehicle can become contaminated and the windows can become misty. Therefore, use this method only for quick heating and change to the normal heating method as soon as possible.

Head cooled/Feet warmed heating

Select "BI-LEVEL" and "FRESH AIR", the temperature selector to the desired temperature position, and the blower speed selector to the desired blower speed position. Unless the temperature selector is in the fully COLD position or fully HOT position, the air that comes out of the center and side outlets will be cooler than the air that comes out of the floor outlets.

Defrosting/Feet warmed heating

Select "HEAT & DEFROST" and "FRESH AIR", the temperature selector to the desired temperature position, and the blower speed selector to HIGH. When the windshield has become clear, set the blower speed selector to the desired blower speed position.

Defrosting

Select "DEFROST" and "FRESH AIR", the temperature selector to the desired temperature position (higher temperature provides more efficient defrosting), and the blower speed selector to HIGH. When the windshield has become clear, set the blower speed selector to the desired blower speed position.

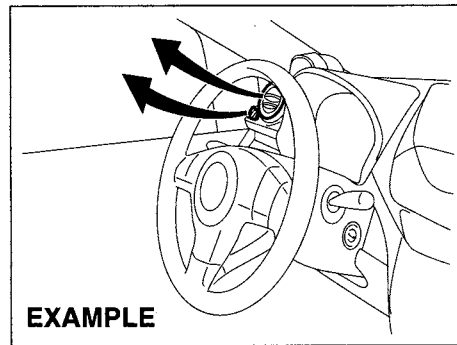

68KM047

NOTE:

If you need maximum defrosting, adjust the temperature selector to the HOT end and adjust the side outlets so the air blows on the side window, in addition to the above Defrosting steps.

OTHER CONTROLS AND EQUIPMENT

Manual Heating and Air Conditioning System

Description of Controls

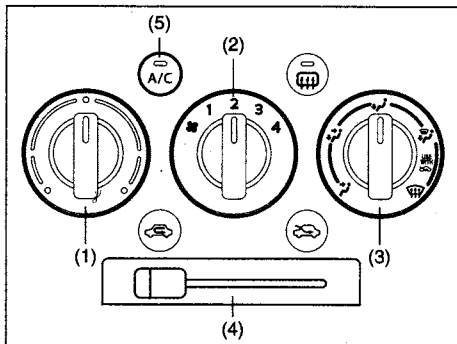

68KH043

Temperature selector (1)

This is used to select the temperature by turning the selector.

Blower speed selector (2)

This is used to turn on the blower and to select blower speed by turning the selector.

Air flow selector (3)

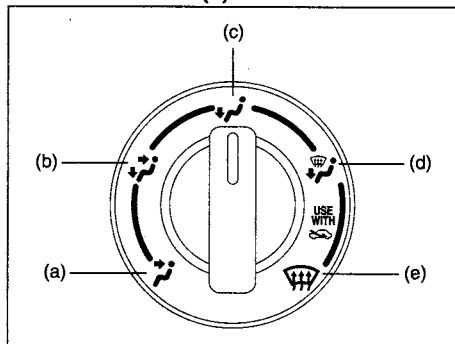

68KH044

This is used to select one of the functions described below.

Ventilation (a)

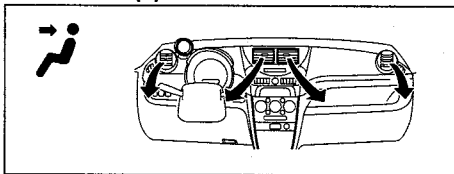

68KM042

Temperature-controlled air comes out of the center and side air outlets.

Bi-level (b)

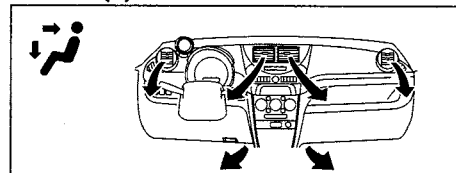

68KM043

Temperature-controlled air comes out of the floor outlets and cooler air comes out of the center and side outlets. When the temperature selector (1) is in the fully COLD position or fully HOT position, however, the air from the floor outlets and the air from the center and side outlets will be the same temperature.

Heat (c)

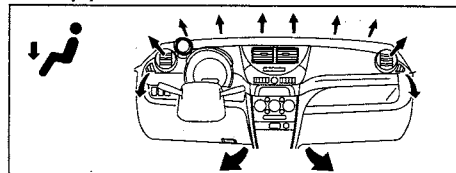

68KM044

Temperature-controlled air comes out of the floor outlets and the side outlets, also comes out of the windshield defroster outlets and also comes slightly out of the side defroster outlets slightly.

Heat & defrost (d)

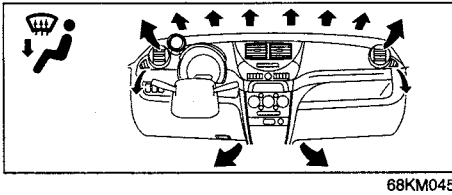

Temperature-controlled air comes out of the floor outlets, the windshield defroster outlets, the side defroster outlets and the side outlets.

Defrost (e)

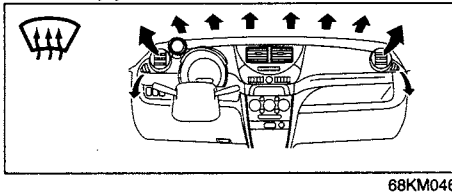

Temperature-controlled air comes out of the windshield defroster outlets, the side defroster outlets and the side outlets.

Air intake selector (4)

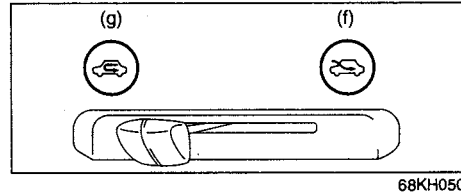

This selector is used to select the following modes.

Fresh Air (f)

When this mode is selected, by moving lever to right outside air is used.

Recirculated Air (g)

When this mode is selected, by moving lever to left, outside air is shut out and inside air is recirculated. This mode is suitable when driving through dusty or polluted air such as in a tunnel, or when attempting to quickly cool down the interior.

NOTE:

If you select "RECIRCULATED AIR" for an extended period of time, the air in the vehicle can become contaminated. Therefore, you should occasionally select "FRESH AIR".

Air conditioning switch (5)

To turn on the air conditioning system, push in the "A/C" switch and set the blower speed selector to a position other than "OFF". With this "A/C" switch operation, a indicator light will come on when the air-conditioning system is on. To turn off the air conditioning system, push the "A/C" switch again.

During operation of the air conditioner, you may notice slight changes in engine speed. These changes are normal, the system is designed so that the compressor turns on or off to maintain the desired temperature.

Less operation of the compressor results in better fuel economy.

OTHER CONTROLS AND EQUIPMENT

System Operating Instructions

Natural ventilation

Select "VENTILATION" and "FRESH AIR", the temperature selector to the desired temperature position, and the blower speed selector to "OFF". Fresh air will flow through the vehicle during driving.

Forced ventilation

The control settings are the same as for natural ventilation except you set the blower speed selector to a position other than "OFF".

Normal heating (using outside air)

Select "HEAT" and "FRESH AIR", the temperature selector to the desired temperature position and the blower speed selector to the desired blower speed position. Setting the blower speed selector to a higher blower speed position increases heating efficiency.

Quick heating (using recirculated air)

The control settings are the same as for normal heating except you select "RECIRCULATED AIR". If you use this heating method for an extended period of time, the air in the vehicle can become contaminated and the windows can become misty. Therefore, use this method only for quick heating and change to the normal heating method as soon as possible.

Head cooled/Feet warmed heating

Select "BI-LEVEL" and "FRESH AIR", the temperature selector to the desired temperature position, and the blower speed selector to the desired blower speed position. Unless the temperature selector is in the fully COLD position or fully HOT position, the air that comes out of the center and side outlets will be cooler than the air that comes out of the floor outlets.

Normal cooling

Turn on the "A/C" switch, set the air flow selector to "VENTILATION", the temperature selector to the desired temperature position and the blower speed selector to the desired blower speed position. Setting the blower speed selector to a higher blower speed position increases cooling efficiency.

You can switch the air intake selector to either "FRESH AIR" or "RECIRCULATED AIR" as you desire. Choosing "RECIRCULATED AIR" increases cooling efficiency.

Quick cooling (using recirculated air)

The control settings are the same as for normal cooling except you select "RECIRCULATED AIR" and the highest blower speed.

NOTE:

- To turn on the air conditioning system, push in the "A/C" switch and set the blower speed selector to a position other than "OFF". With this "A/C" switch operation, an indicator light will come on when

the air conditioning system is on. To turn off the air conditioning system, push the "A/C" switch again.

- During operation of the air conditioner, you may notice slight changes in engine speed. These changes are normal, the system is designed so that the compressor turns on or off to maintain the desired temperature. Less operation of the compressor results in better fuel economy.

NOTE:

- If you select "RECIRCULATED AIR" for an extended period of time, the air in the vehicle can become contaminated. Therefore, you should occasionally select "FRESH AIR".
- If your vehicle has been left in the sun with the windows closed, it will cool faster if you open the windows briefly while you operate the air conditioner with the air intake selector at "FRESH AIR" and the blower at high speed.

Dehumidifying

Turn on the "A/C" switch, set the air flow selector to the desired air flow selector position, and select "FRESH AIR", the temperature selector to the desired temperature position, and the blower speed selector to the desired blower speed position.

NOTE:

Because the air conditioner dehumidifies the air, turning it on will help keep the windows clear, even when blowing heated air using the "DEFROST" or "HEAT & DEFROST" functions.

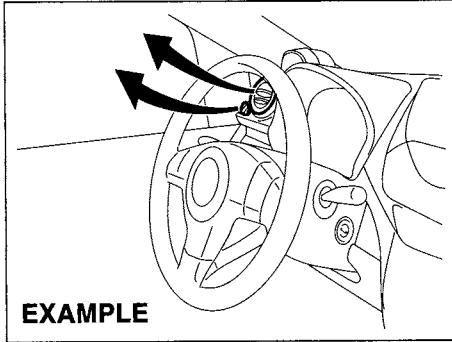

68KM047

NOTE:

If you need maximum defrosting:

- set the air flow selector to "DEFROST",
- set the blower speed selector to HIGH,
- adjust the temperature selector to the HOT end, and
- adjust the side outlets so the air blows on the side windows.

Maintenance

If you do not use the air conditioner for a long period, such as during winter, it may not give the best performance when you start using it again. To help maintain optimum performance and durability of your air conditioner, it needs to be run periodically. Operate the air conditioner at least once a month for one minute with the engine idling. This circulates the refrigerant and oil and helps protect the internal components.

NOTE:

Your vehicle uses the air conditioning refrigerant HFC-134a, commonly called "R-134a". R-134a replaced R-12 around 1993 for automotive applications. Other refrigerants are available, including recycled R-12, but only R-134a should be used in your vehicle.

CAUTION

Using the wrong refrigerant may damage your air conditioning system. Use R-134a only. Do not mix or replace the R-134a with other refrigerants.

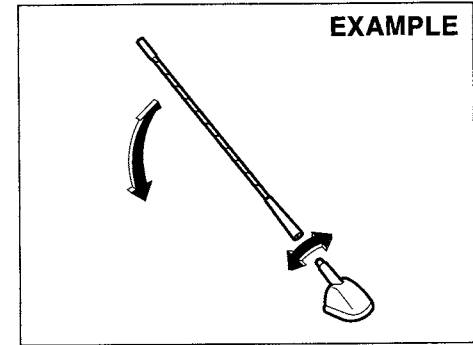
Radio Antenna

68KH052

The radio antenna on the roof is removable. To remove the antenna, turn it counterclockwise. To reinstall the antenna, turn it clockwise firmly by hand.

CAUTION

To avoid damage to the radio antenna:

- Remove the antenna when using an automatic car wash.
- Remove the antenna when the antenna hits anything such as a low ceiling in a parking garage or putting a car cover over your car.

Installation of Radio Frequency Transmitters

We recommend that you always SUZUKI dealer about frequency band, max output power, antenna position at vehicle and specific conditions for installation and/or use before installing a radio transmitter in your vehicle. Such equipments may cause the electronic control system to malfunction if they are incorrectly installed or they are not suited for the vehicle.

Audio Systems AM/FM CD PLAYER

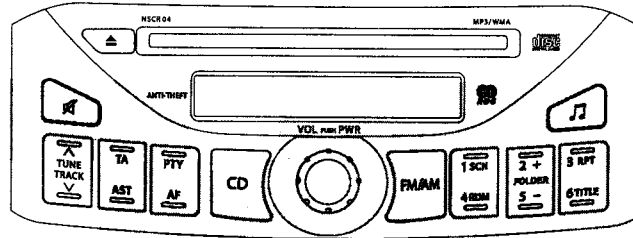

68KM048

Precautions

- When the inside of the car is very cold and the player is used soon after switching on the heater, moisture may form on the disc or the optical parts of the player and proper playback may not be possible. If moisture forms on the disc, wipe it off with a soft cloth. If moisture forms on the optical parts of the player, do not use the player for about one hour. This will allow the condensation to disappear normally.
- Driving on extremely bumpy roads which cause severe vibrations may cause sound to skip.
- This unit uses a precision mechanism. Even in the event that trouble arises, never open the case, disassemble the unit, or lubricate the rotating parts. Please bring the unit to an authorized SUZUKI dealer.

Cautions on Handling



52D274

This unit has been designed specifically for playback of compact discs bearing the mark (A).

No other discs can be played.

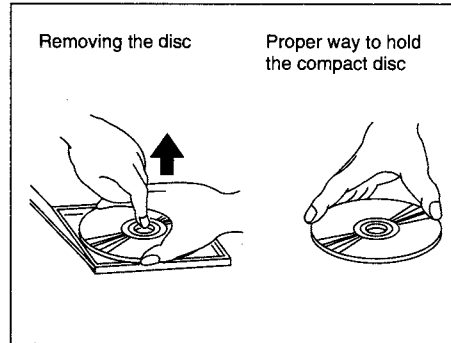

52D275

To remove the compact disc from its storage case, press down on the center of the case and lift the disc out, holding it carefully by the edges.

Always handle the compact disc by the edges.

Never touch the surface.

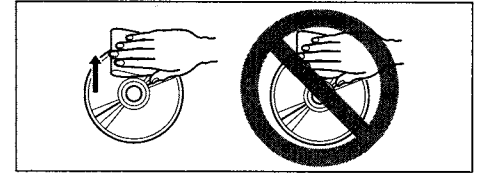

52D347

To remove fingermarks and dust, use a soft cloth, and wipe in a straight line from the center of the compact disc to the circumference.

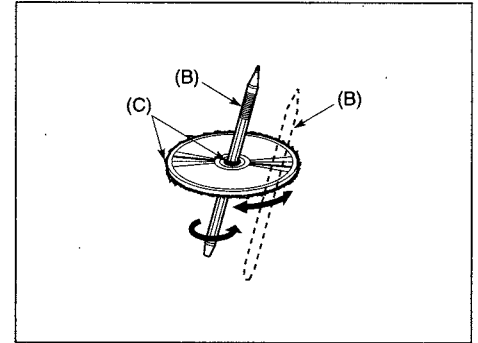

52D277

New discs may have some roughness around the edges. The unit may not work or the sound may skip if such discs are used. Use a ball-point pen (B), etc. to remove the roughness (C) from edges of the disc before insertion inside the unit.

OTHER CONTROLS AND EQUIPMENT

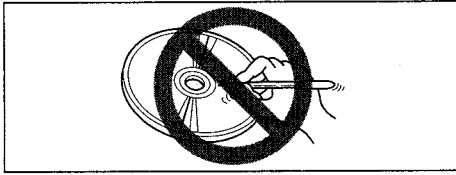

52D348

Never stick labels on the surface of the compact disc or mark the surface with a pencil or pen.



52D349

Do not use any solvents such as commercially available cleaners, anti-static spray, or thinner to clean compact discs.

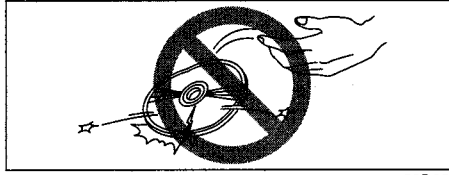

52D350

Do not use compact discs that have large scratches, are misshaped, or cracked, etc. Use of such discs will cause damage or prevent the system from operating properly.

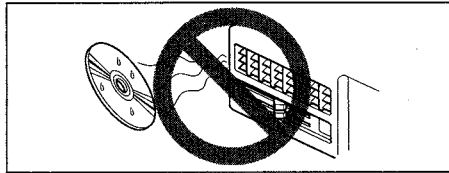

52D351

Do not expose compact discs to direct sunlight or any heat source.

NOTE:

- Do not use commercially available CD protection sheets or discs equipped with stabilizers, etc. These may get caught in the internal mechanism and damage the disc.
- CD-R/RW discs may not be able to playback in this unit due to the recording conditions.

Basic Operations
AM/FM CD PLAYER

- (1) Power on/off knob
Volume control knob
- (2) Sound button
- (3) Mute button

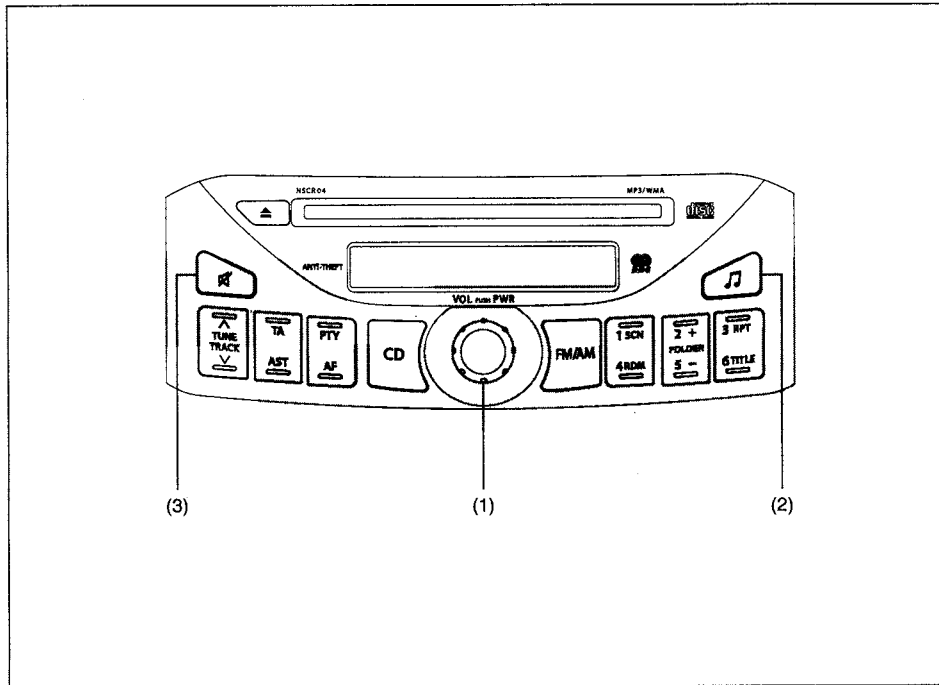

68KM049

OTHER CONTROLS AND EQUIPMENT

Turning Power on/off

Press the Power on/off knob (1).

The unit starts in the function mode it was in when the power was turned off last.

Adjusting the volume

Turn the Volume control knob (1).

Turning it clockwise increases the volume; turning it counterclockwise decreases the volume.

NOTE:

While driving, adjust the volume to an extent that sound and/or noise coming from outside the car can be heard.

Mute

1) Press the Mute button (3).

Press the Mute button (3) again, it returns to the original volume.

Adjusting bass/treble/balance/fader

1) Press the Sound button (2).

Each time it is pressed, sound adjustment is changed as follows:

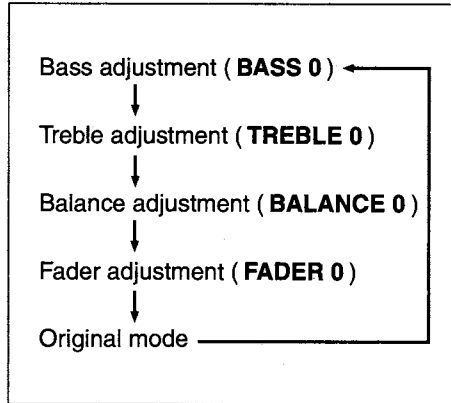

68KH108

2) Turn the Volume control knob (1) to adjust the sound.

Listening to the Radio
AM/FM CD PLAYER

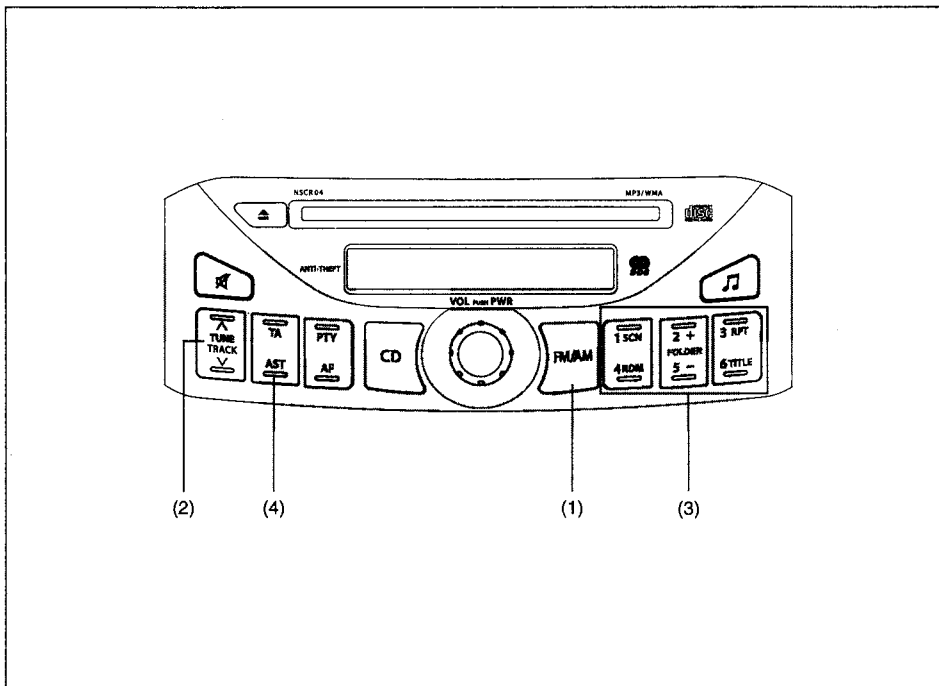

68KM050

Display

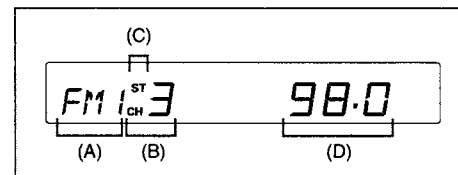

68KH111

- (1) Band switch button
- (2) Tune / Track button
- (3) Preset buttons
- (4) AST button

- (A) Band
- (B) Preset channel number
- (C) Stereo indicator
- (D) Frequency

OTHER CONTROLS AND EQUIPMENT

Selecting the reception band

Press the Band switch button (1). Each time the button is pressed, the reception band is switched as follows:

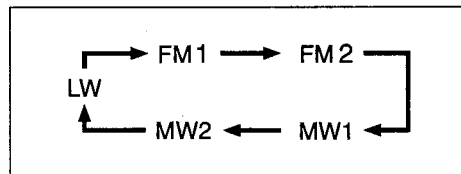

68KM051

Seek tuning

Press longer Tune / Track button (2) to up or down.

The unit stops searching for a station at a frequency where a broadcast station is available.

Manual tuning

Press Tune / Track button (2) to up or down.

The frequency being received is displayed.

Preset memory

- 1) Select the desired station.
- 2) Select the Preset button (3) to which you want to store the station and press and hold the button for more than 1.5 seconds.

Auto store

Press and hold the AST button (4) for more than 1.5 seconds.

6 stations in total are automatically stored to the Preset buttons (3) in sequential order, starting from the lower frequencies.

NOTE:

- If no station can be received after Auto Store is performed, “- -” appears in the display.
- If fewer than 6 stations can be received, the system will memorize as many stations as possible, then select the strongest one.

Radio Reception

Radio reception can be affected by environment, atmospheric conditions, or radio signal's power and distance from the station. Nearby mountains and buildings may interfere or deflect radio reception, causing poor reception. Poor reception or radio static can also be caused by electric current from overhead wires or high voltage power lines.

**RDS (Radio Data System)
AM/FM CD PLAYER**

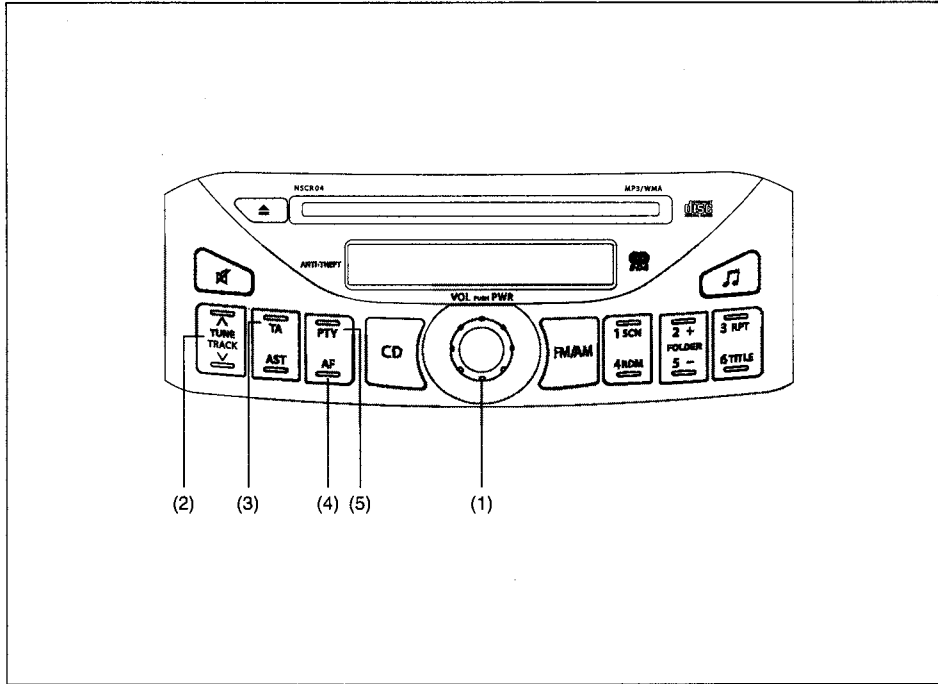

68KM052

Display

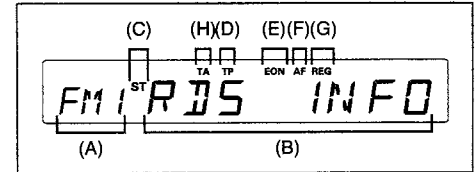

68KM053

- (1) Volume control knob
- (2) Tune / Track button
- (3) TA button
- (4) AF button
- (5) PTY button

- (A) Band
- (B) RDS data information
- (C) Stereo indicator
- (D) TP indicator
- (E) EON indicator
- (F) AF indicator
- (G) REG indicator
- (H) TA indicator

OTHER CONTROLS AND EQUIPMENT

What is RDS?

Some FM stations are broadcasting added data compatible with RDS. This radio set offers convenient functions using such data.

RDS service availability varies with areas. Please understand the following functions are not available in some areas.

• AF (Alternative Frequency)

The unit searches for a station in better receiving condition that emits the same programme as now received, and automatically selects that station.

• REG (Region)

An area in which the AF function may be used to select stations can be set. When REG is ON, the AF function is effective in the present area only.

• PS (Program Service Name)

Instead of the frequency, the name of the broadcast station appears.

• PTY (Program Type)

Programs can be searched for by PTY.

• TA (Traffic Announcement)

The unit can search for stations emitting TP (traffic programmes), and tune in to such stations in preference to others. Stations emitting TP are called TP stations.

• EON (Enhanced Other Network)

RDS information is updated constantly in response to the current position. The "EON" indicator remains lit while RDS information is received.

• Emergency Announcement Reception

When Emergency Announcement is received, the unit will automatically switch to FM band (except MW or LW band) and display "ALARM".

AF/REG On/Off

Each time the AF button (4) is pressed, AF/REG changes as follows:

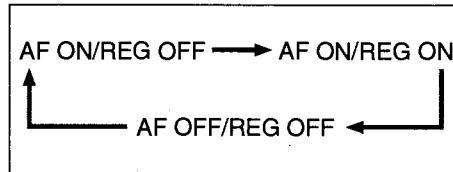

68KM056

The AF indicator (F) lights up when AF is ON. In addition to that, the REG indicator (G) lights up when REG is ON.

TA On/Off

Press the TA button (3) to turn TA on. Press the TA button (3) again to turn TA off. When TA is turned on, the TA indicator (H) lights.

The TP indicator (D) remains lit while TP data is being received.

NOTE:

- If Tune/Track button (2) is pressed longer while TA is turned on, the unit searches for TP stations and display "TP SEEK".
- If no TP station is received, the unit displays "NONE".

TA Standby

If TP is received when TA is ON in CD mode, radio mode is automatically selected. The unit returns to the preceding mode after TP.

PTY Search

Programs can be searched for by PTY.

- 1) Press the PTY button (5) to select PTY mode.
- 2) Turn the volume control knob (1) to select a desired PTY.

Turning the Volume control knob (1) clockwise changes the items in the following orders. (Turning it counter clockwise changes them in the reverse order.)

NONE / NEWS / AFFAIRS / INFO / SPORT / EDUCATE / DRAMA / CULTURE / SCIENCE / VARIED / POP M / ROCK M / EASY M / LIGHT M / CLASSICS / OTHER M / WEATHER / FINANCE / CHILDREN / SOCIAL / RELIGION / PHONE IN / TRAVEL / LEISURE / JAZZ / COUNTRY / NATION M / OLDIES / FOLK M / DOCUMENT / NEWS . . .

- 3) Press the Tune / Track button (2) while PTY is displayed, search begins.

NOTE:

If the specified PTY is not received, the unit displays "NONE", and then back to last PTY mode again.

Listening to a CD

52D274

- CDs or CD-ROMs carrying no mark (A) cannot be used.
- Some discs previously recorded in CD-R/CD-RW format may not be used.

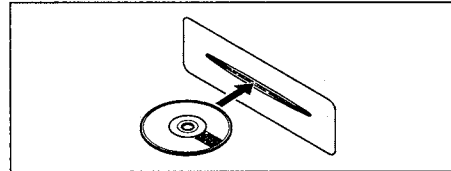

52D291

- A CD is inserted with its label facing upward.
- When there is a CD already loaded in the unit, another CD cannot be loaded at the same time. Do not use force when inserting the CD into the CD insertion slot.
- If a blank disc (non-recorded CD-R) is loaded in the unit, the disc will be ejected.

CAUTION

- Never insert your finger or hand into the CD insertion slot. Never insert foreign objects.
- Never insert a CD with glue coming out from adhesive tape or a rental CD label or with a trace indicating that adhesive tape or a rental CD label has been removed. This may cause the CD not to eject or result in a malfunction.

OTHER CONTROLS AND EQUIPMENT

AM/FM CD PLAYER

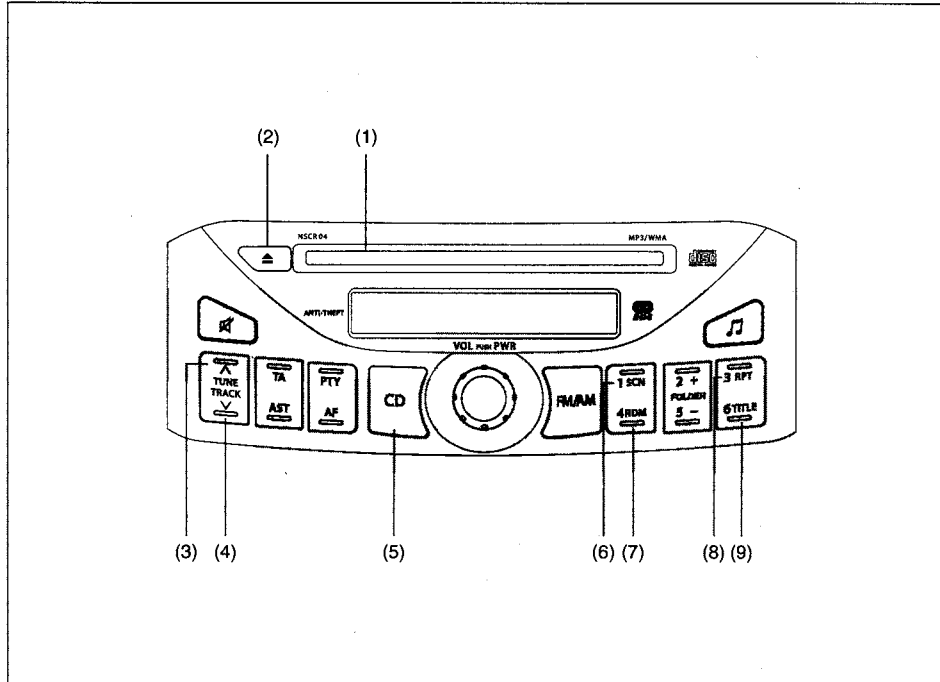

68KM054

Display

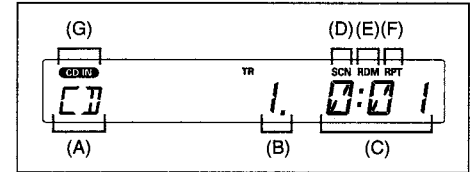

68KH114

- (1) CD slot
- (2) Eject button
- (3) Track up / Fast forward button
- (4) Track down / Fast rewind button
- (5) CD button
- (6) Scan button
- (7) Random button
- (8) Repeat button
- (9) Title button

- (A) Mode indicator
- (B) Track number
- (C) Play time
- (D) Scan indicator
- (E) Random indicator
- (F) Repeat indicator
- (G) Disc indicator

NOTE:**About Single CDs (8 cm CDs)**

- No adapter is required to play a single CD.
- A single CD is inserted from the center of the CD insertion slot.
- Since an ejected single CD is not automatically reloaded, be sure to remove the ejected single CD.

Loading a CD

Insert a CD in the CD slot (1).

When a CD is loaded, play starts and the CD indicator (A) lights.

Ejecting a CD

Press the Eject button (2).

If you left a CD ejected for a period of about 10 seconds, it will be automatically drawn inside the unit. (Auto reload function)

CAUTION

If you forcefully try to push an ejected CD inside the unit before auto reloading, the disc surface might be scratched.

Listening to a CD

When a CD is inserted, it is automatically played back.

When a CD is already inside the unit, press the CD button (5) to play back the CD. When a CD is inside the unit, the CD indicator (A) (G) is lit on the display unit.

Selecting a track

- Press the Track up button (3) to listen to the next track.
- Press the Track down button (4) twice to listen to the previous track.

When the Track down button (4) is pressed once, the track being currently played will return to the beginning.

Fast forwarding/Rewinding a track

- Hold in the Fast forward button (3) to advance a track rapidly.
- Hold in the Fast rewind button (4) to rewind a track rapidly.

Repeat play

Press the Repeat button (8).

Each time the button is pressed, repeat play mode changes as follows:

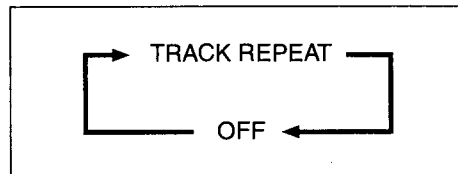

68KH115

- Track repeat
Repeat indicator (F) lights up. The track currently being played is played repeatedly.

OTHER CONTROLS AND EQUIPMENT

Random play

Press the Random button (7).
Each time the button is pressed, random play mode changes as follows:

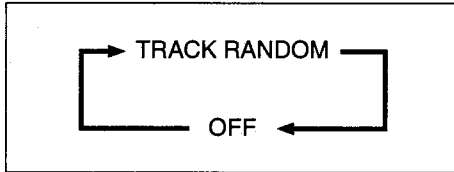

68KH116

- Track random
Random indicator (E) lights up.
The tracks are played randomly.

Scan play

Press the Scan button (6).
Each time the button is pressed, scan play mode changes as follows:

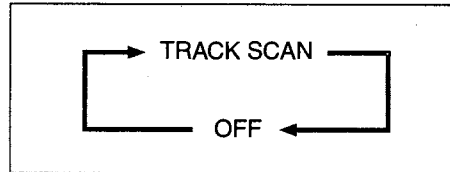

68KH117

- Track scan
Scan indicator (D) lights up.
Each track is sequentially played first 10 seconds.

Displaying CD Title

Press the Disc title / Track title button (9).
Each time this button is pressed, display will change as follows:

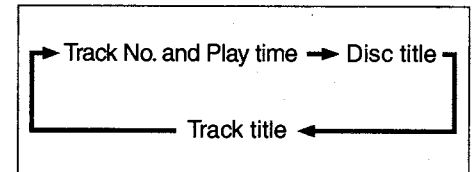

68KH118

Forwarding a Title

When Disc title or Track title is displayed, press longer the Title button (9) to display the remaining characters if it is more than 8 characters.

A total of 16 characters can be displayed.

- * If the number of characters is 8 or less, display does not scroll.

**Listening to an MP3/WMA Disc
AM/FM CD PLAYER**

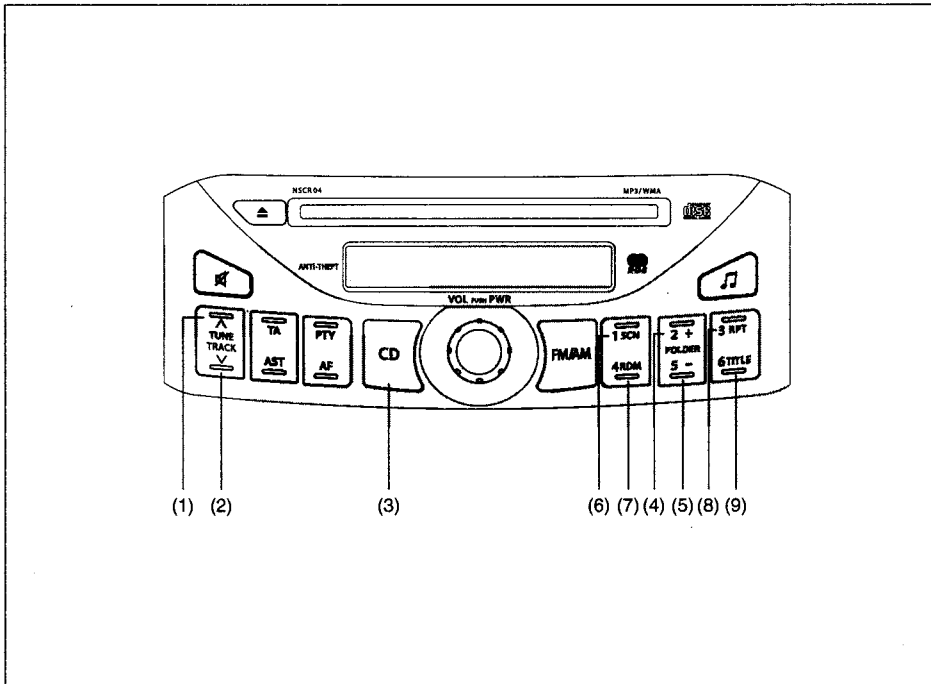

68KM055

Display

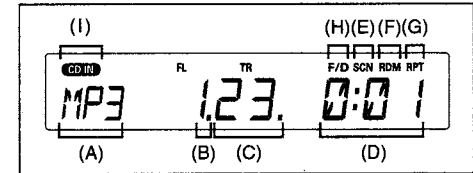

68KM061

- (1) Track up / Fast forward button
- (2) Track down / Fast rewind button
- (3) CD button
- (4) Folder up button
- (5) Folder down button
- (6) Scan button
- (7) Random button
- (8) Repeat button
- (9) Title button

- (A) Mode indicator
- (B) Folder number
- (C) Track number
- (D) Play time
- (E) Scan indicator
- (F) Random indicator
- (G) Repeat indicator
- (H) Folder indicator
- (I) Disc indicator

What is MP3/WMA?

MP3 (MPEG1/2 Audio Layer-III) and WMA (Windows Media™ Audio) are the compression formats of digital audio. The former is developed by MPEG (Motion Picture Experts Group), and the latter is developed by Microsoft Corporation. Using these compression formats, you can record the contents of about 10 music CDs on a single CD media (This figures refer to data recorded on a 650 MB CD-R or CDRW at a fixed bit rate of 128 kbps and a sampling frequency of 44.1 kHz).

Points to remember when making MP3/WMA files

Common

- High bit rate and high sampling frequency are recommended for high quality sounds.
- Selecting VBR (Variable Bit Rate) is not recommended because playing time is not displayed properly and sound may be skipped.
- The playback sound quality differs depending on the encoding circumstances. For details, refer to the user manual of your own encoding software and writing software.

MP3

- It is recommended to set the bit rate to "128 kbps or more" and "fixed".

WMA

- It is recommended to set the bit rate to "64 kbps or more" and "fixed".
- Do not set the copy protect attribute on the WMA file to enable this unit to play back.

CAUTION

Never assign the ".mp3", or ".wma" file name extension to a file that is not in the MP3/WMA format. This may not only produce noise from the speaker damage, but also damage your hearing.

Recording MP3/WMA files on a CDmedia

- If CD-DA files are on the same disc as MP3 or WMA files, the songs may not play in the intended order, or some songs may not play at all.
- When storing MP3 data and WMA data on the same disc, use different folders for each data.
- Do not record files other than MP3/WMA files and unnecessary folder on a disc.
- The name of an MP3/WMA file should be added by rules as shown in the following descriptions and also comply with the rules of each file system.
- The file extension ".mp3" or ".wma" should be assigned to each file depending on the file format.
- You may encounter trouble in playing MP3/WMA files or displaying the infor-

mation of MP3/WMA files recorded with certain writing software or CD recorders.

- This unit does not have a play list function.
- Although Multi-session recording is supported, the use of Disc-at-Once is recommended.

Compression formats

MP3

- Bit rate
 - MPEG1 Audio Layer III : 32 k – 320 kbps
 - MPEG2 Audio Layer III : 8 k – 160 kbps
- Sampling frequency
 - MPEG1 Audio Layer III : 44.1 k/48 k/32 kHz
 - MPEG2 Audio Layer III : 22.05 k/24 k/16 kHz

WMA (Ver.7, Ver.8)

- Bit rate
 - 32 k – 192 kbps
- Sampling frequency
 - 44.1 k/48 k/32 kHz

Supported file systems

ISO 9660 Level 1/Level 2/Level 3, Joliet, Romeo

Maximum number of files/folders

- Maximum number of files:
 - CD Player: 512 (files + folders)
- Maximum number of files in one folder: 255
- Maximum depth of trees: 8
- Maximum number of folders: 255 (Root folder is included.)

MP3/WMA MODE

Selecting a folder

- Press the Folder up button (4) to select the next folder.
- Press the Folder down button (5) to select preceding folder.
- It may take a few moment until a folder is selected.

Repeat Play

- **Track Repeat**
Press the Repeat button (8). The Repeat indicator (G) lights up. The current track is played repeatedly.
- **Folder Repeat**
Press the Repeat button (8) for more than 1.5 seconds. The Folder Repeat indicator (H) (G) lights up. The current folder is played repeatedly.

To cancel the track repeat or folder repeat, press the Repeat button (8) again.

Random Play

- **Track Random**
Press the Random button (7). The Random indicator (F) lights up. The tracks on the disc is played randomly.
- **Folder Random**
Press the Random button (7) for more than 1.5 second. The Folder Random indicator (H) (F) lights up. All the tracks in the current folder is played randomly.

To cancel the track random or folder random press the Random button (7) again.

Scan Play

- **Track Scan**
Press the Scan button (6). The Scan indicator (E) lights up. The first 10 seconds of each track on the disc is played.
- **Folder Scan**
Press the Scan button (6) for more than 1.5 seconds. The Folder Scan indicator (H) (E) lights up. Play the first 10 seconds of first track in each folder and keep moving to next folder.

To cancel the track scan or folder scan press Scan button (6) again.

Selecting a track

- Press the Track up button (1) to listen to the next track.
- Press the Track down button (2) twice to listen to the previous track.
When the Track down button (2) is pressed once, the track currently being played will start again at the beginning.

Fast forwarding/Rewinding a track

- Hold in the Fast forward button (1) to advance a track rapidly.
- Hold in the Fast rewind button (2) to rewind a track rapidly.

Displaying CD Title

- Press Title button (9) .
- Each time this button is pressed, display will changed as follows.

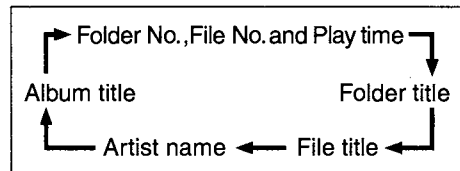

68KH121

Forwarding a Title

- When Folder Title, File Title, Artist Name and Album Title is displayed, press longer the Title button (9) to display the remaining characters if it is more than 8 characters.
- A total of 16 characters can be displayed. If the number of characters is 8 or less, display does not scroll.

OTHER CONTROLS AND EQUIPMENT

Anti-Theft Feature AM/FM CD PLAYER

- (1) Power on/off knob
- (2) Track up button
- (3) Preset buttons (1 to 6)

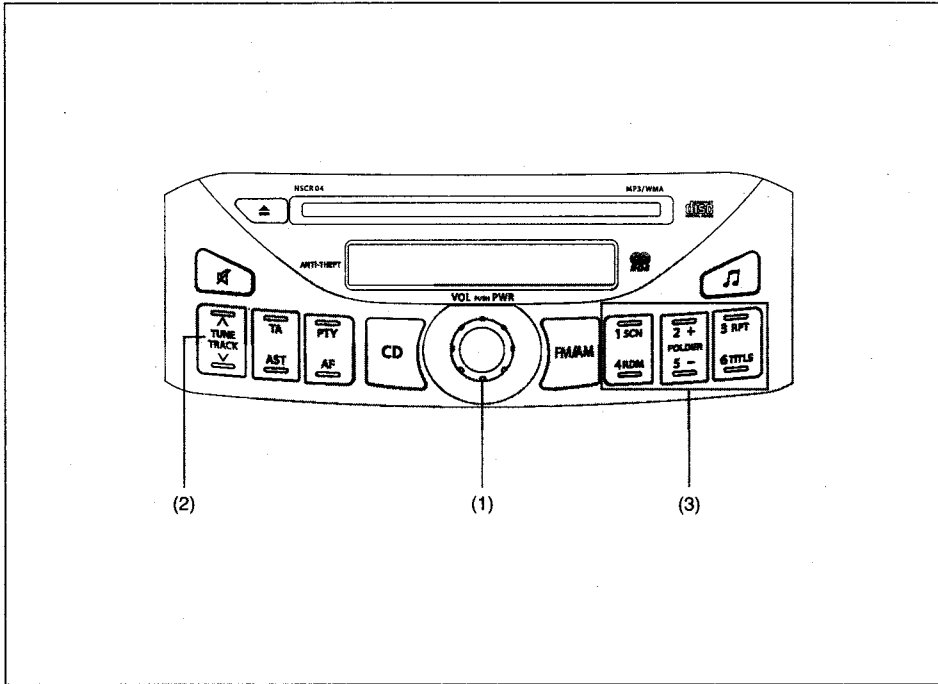

68KM058

The anti-theft feature is intended to discourage theft by preventing the audio system from operating when it is moved to a different vehicle.

This feature works by allowing you to enter a Personal Identification Number (PIN). When the audio system is disconnected from its power source, such as when the audio system is removed or the battery is disconnected, the system will not operate again unless the PIN is reentered.

Setting the Anti-Theft Function

- 1) Turn off the power by pressing the Power on/off knob (1).
- 2) Press the Power on/off knob (1) while pressing and holding the Track Up button (2). The "ENT 0000" will blink and the audio system enter PIN-input mode.

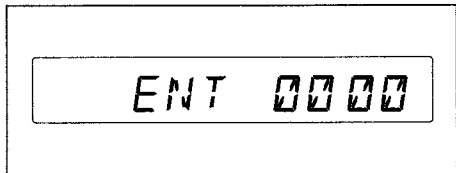

68KM059

CAUTION

Establish your PIN by combining numbers from 1 to 6 into any 4-digit number. If you forget your PIN, when you remove the battery for repair etc., you will no longer be able to operate the audio system.

- 3) Input the four digit PIN using Preset buttons 1 to 6.

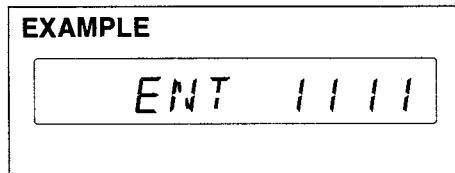

68KM060

- 4) After you enter your four digit PIN, the display will return to "ENT 0000".

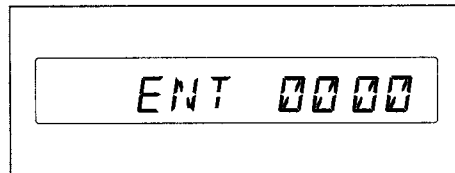

68KM059

- 5) Input the same 4-digit number you previously entered.

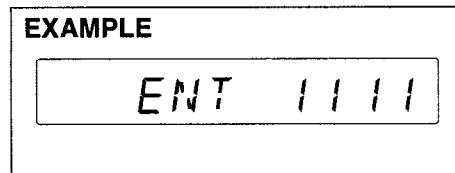

68KM060

- 6) The power of the audio system will turn off.

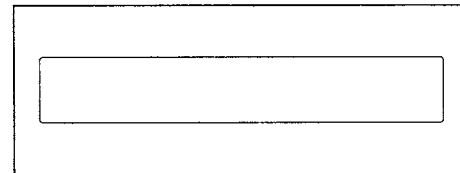

68KM063

NOTE:

Write down your PIN for the future use.

Canceling Your Established PIN Setting

This operation is to be done when you want to cancel the anti-theft function or change your PIN.

- 1) Turn off the power by pressing the Power on/off knob (1).
- 2) Press the Power on/off knob (1) while pressing and holding the Track up button (2). The "DEL 0000" will blink and the audio system will enter the cancel mode.

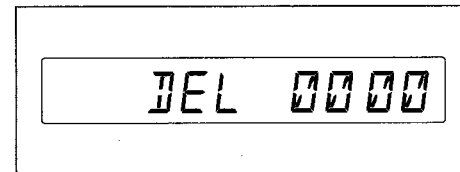

68KM064

OTHER CONTROLS AND EQUIPMENT

- 3) Input your PIN. The power of the audio system will turn off and your PIN will be deleted. To change your PIN, first delete your current PIN, then set a new one.

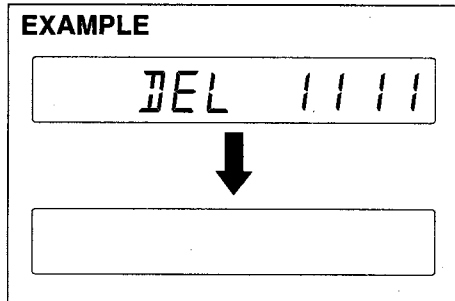

68KM065

- 2) Input your PIN.
If the PIN that you input matches the registered PIN, the power of the audio system will turn off, and you will be able to operate the audio system.

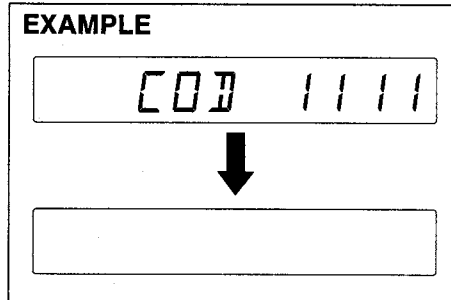

68KM067

Confirming Your Personal Identification Number (PIN)

When the main power source is disconnected such as when you exchange your battery, etc, you will have to confirm your PIN to be able to use the audio system.

To confirm your PIN:

- 1) Turn the ignition switch to the "ACC" position.

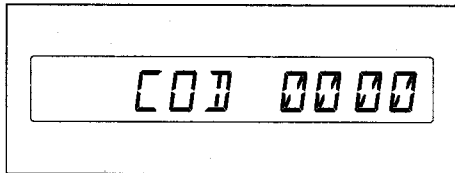

68KM066

iPod/USB adaptor AM/FM CD PLAYER

If you use iPod/USB adaptor (option), you can use iPod or USB. Please refer the manual in the adaptor about the detailed directions.

NOTE:

- If you input your PIN incorrectly, "----" will be displayed and the anti-theft function-lock mode is entered. If you enter an incorrect PIN, the locking time will be for 15 seconds.
- If you forget your PIN and enter a wrong PIN, you cannot perform any further operation.

Troubleshooting

Applicable to every device

Phenomenon	Cause	Remedy
Power is not turned on. (No sound is produced)	Fuse is blown.	Contact your authorized SUZUKI dealer.
	Connections are not properly made.	Contact your authorized SUZUKI dealer.

Radio

Phenomenon	Cause	Remedy
Too much noise.	Not tuned correctly to the frequency of a station.	Tune correctly to the station frequency.
Stations cannot be selected by seek tuning.	There is no station with strong radio waves.	Select stations by manual tuning.

CD

Phenomenon	Cause	Remedy
Compact disc cannot be loaded.	Another compact disc is already loaded.	Eject the compact disc before loading a new one.
Sound skips or is noisy.	Compact disc is dirty.	Clean the compact disc with a soft cloth.
	Compact disc is heavily scratched or warped.	Replace with a compact disc with no scratches.
Sound is bad directly after power is turned on.	Water droplets may form on the internal lens when the car is parked in a humid place.	Let dry for about 1 hour with the power on.

OTHER CONTROLS AND EQUIPMENT

Error display

This unit has a number of self-diagnostic functions to protect the system.

If a problem should occur, the display shows the type of error. Refer to the table below and take proper measures to correct the problem.

If the problem is corrected, the unit will operate normally.

DISPLAYED MESSAGE	SITUATION	UNIT OPERATION
	 Disc is inserted up side down.	Reinsert correctly with the printed side upwards.
	 Disc is dirty.	Clean the disc with a soft cloth.
	 The disc is damaged.	Check the disc, and try another disc. If there is no problem, the disc might damage.
	 The disc or data that cannot be played is inserted.	Select playable data, or insert playable disc.
	 Disc both music CD data (CD-DA) and MP3 / WMA file data are existed is inserted.	Select playable data, or insert playable disc.

If an error display not listed above appears, turn off the unit and contact your SUZUKI dealer.

Fuel Filler Cap

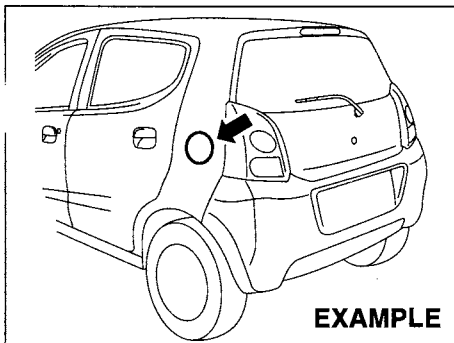

68KM068

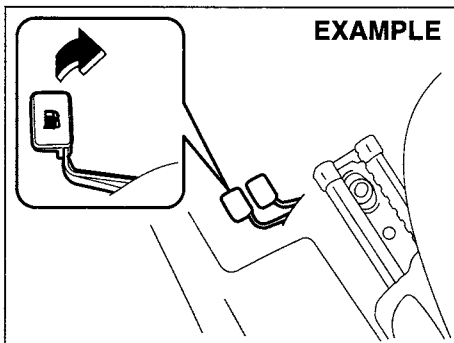

68KM069

The fuel filler cap is located on the left rear side of the vehicle. The fuel filler door can be unlocked by pulling up the opener lever located on the outboard side of the driver's seat and locked by simply closing the door.

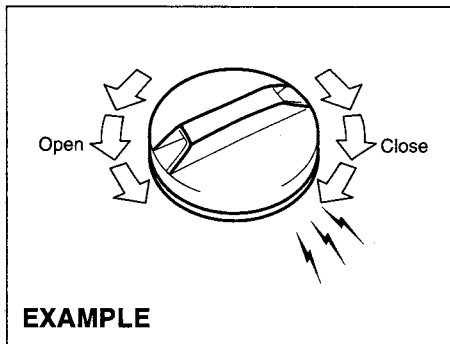

68KN048

To remove the fuel filler cap:

- 1) Open the fuel filler door.
- 2) Remove the cap by turning it counter-clockwise.

⚠ WARNING

Remove the fuel filler cap slowly. The fuel may be under pressure and may spray out, causing injury.

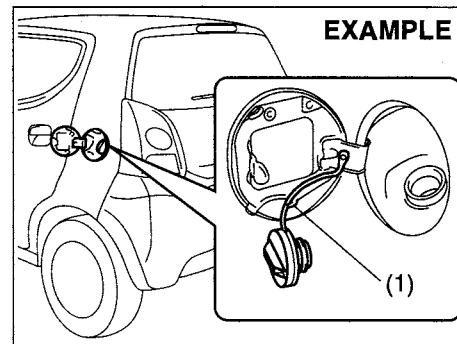

68KN049

NOTE:

The cap holder (1) can hold the fuel filler cap when refueling.

To reinstall the fuel filler cap:

- 1) Turn the cap clockwise until you hear several clicks.
- 2) Close the fuel filler door.

⚠ WARNING

Gasoline is extremely flammable. Do not smoke when refueling, and make sure there are no open flames or sparks in the area.

WARNING

If you need to replace the fuel cap, use a genuine SUZUKI cap. Use of an improper cap can result in a malfunction of the fuel system or emission control system. It may also result in fuel leakage in the event of an accident.

Engine Hood

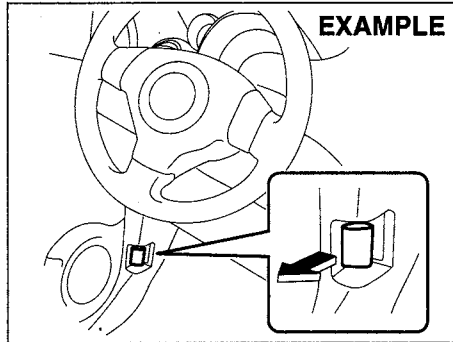

68KM071

To open the engine hood:

- 1) Pull the hood release handle located on the outboard side. This will disengage the engine hood lock halfway.

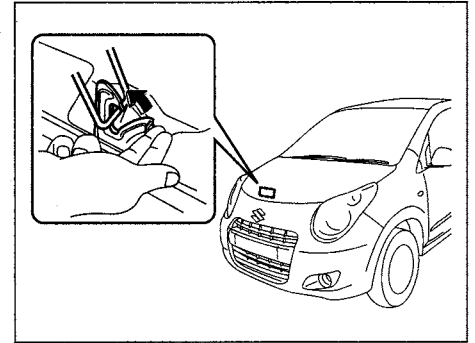

68KH055

- 2) Push the under-hood release lever up with your finger, as shown in the illustration. While pushing the lever, lift up the engine hood.

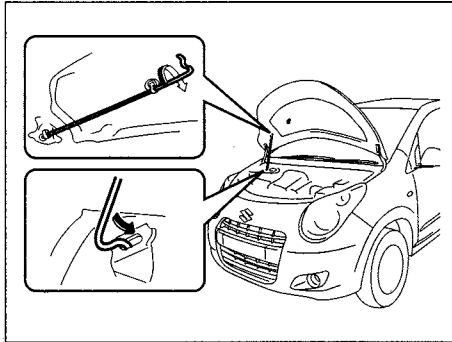

68KH056

- 3) Continue to lift up the hood until it is high enough to support with the prop rod.

To close the engine hood:

- 1) Lift the hood up slightly and remove the prop rod from the hole. Put the prop rod back to the holding clip.
- 2) Lower the hood close to the bumper, then let it drop down.
Make sure the hood is securely latched after closing.

⚠ WARNING

Make sure the hood is fully closed and latched before driving. If it is not, it can fly up unexpectedly during driving, obstructing your view and resulting in an accident.

Sun Visor

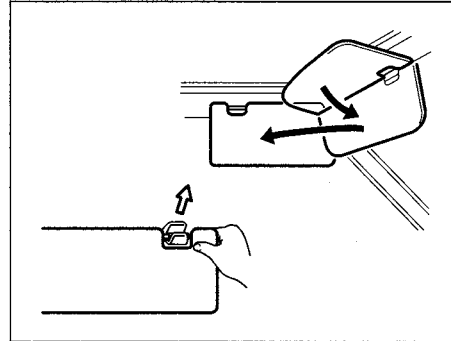

79J161

The sun visors can be pulled down to block glare coming through the windshield, or they can be unhooked and turned to the side to block glare coming through the side window.

CAUTION

When unhooking and hooking a sun visor, be sure to handle it by the hard plastic parts or the sun visor can be damaged.

Interior Light Switch

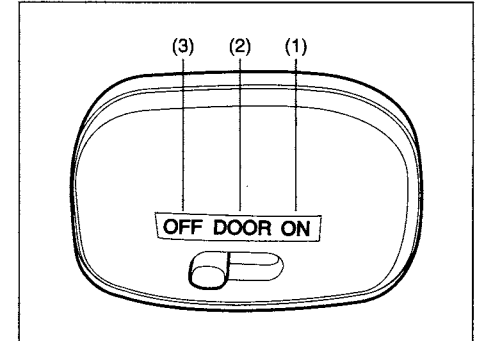

82JN065

This light switch has three positions which function as described below:

- (1) The light comes on and stays on regardless of whether the door is open or closed.
- (2) The light comes on when the door is opened.

After closing all doors, the light will remain on for about 15 seconds and then fade out. If you insert the key into the ignition switch during that time, the light will start to fade out immediately.

After removing the key from the ignition switch, the light will turn on for about 15 seconds and then fade out.

- (3) The light remains off even when the door is opened.

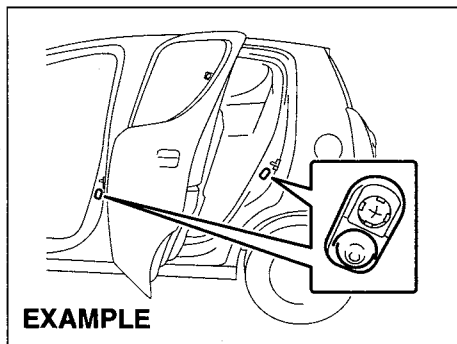

68KM072

NOTE:

The number of doors involved in the lighting operation of the interior light depends on the vehicle specification. If there is a switch (rubber projection) at the door opening as shown, the door is involved in the lighting operation. The tailgate is also involved in this operation even without the rubber projection.

Accessory Socket (if equipped)

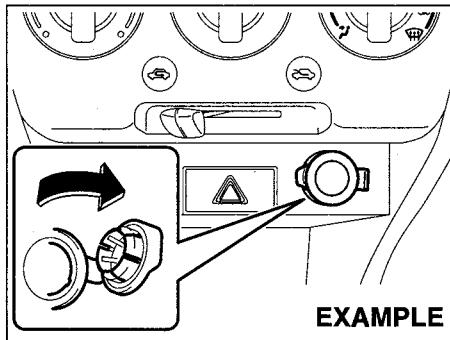

68KM073

The accessory socket will work when the ignition switch is in the "ACC" or "ON" position. This socket can be used to provide 12 volt/120 watt power for electrical accessories.

CAUTION

Use of inappropriate electrical accessories can cause damage to your vehicle's electrical system. Make sure that any electrical accessories you use are designed to plug into this type of socket.

Glove Box

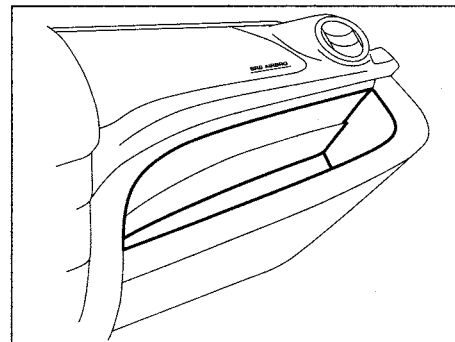

68KM074

The glove box is provided on the instrument panel.

⚠ WARNING

Do not put objects in the glove box which are dropped easily while the vehicle is moving. Objects in the glove box may be thrown and stuck between pedal and floor about during a sudden stop or impact, and could cause an accident.

Cup Holder (if equipped)

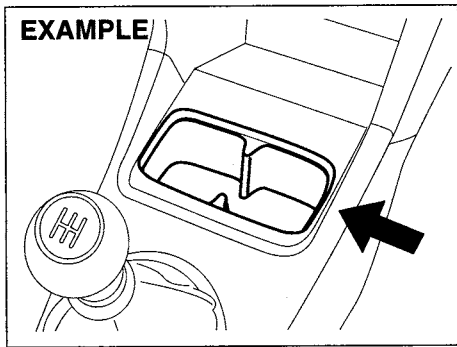

The cup holders are provided in the center console.

⚠ WARNING

Do not use the cup holder to hold cups containing hot liquids, or sharp-edged, hard or breakable objects. Objects in the cup holder may be thrown about during a sudden stop or impact, and could cause personal injury.

Bottle holder (rear)

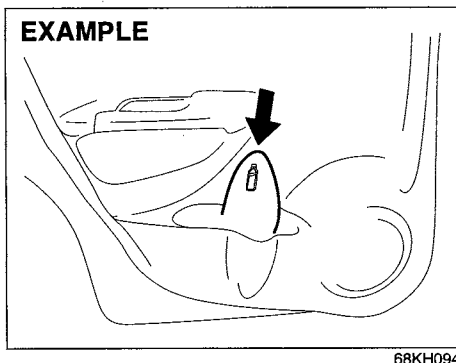

You should hold a bottle with a cap in the bottle holder.

Luggage Area Cover (if equipped)

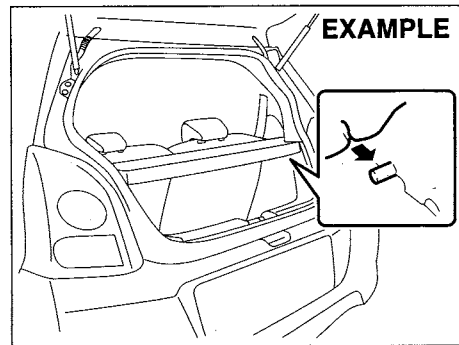

Luggage or other cargo placed in the luggage compartment is hidden from view by a luggage area cover.

⚠ WARNING

Do not carry items on top of the luggage area cover, even if they are small and light. Objects on top of the cover could be thrown about in an accident, causing injury, or could obstruct the driver's rear view.

CAUTION

To avoid damaging the luggage area cover:

- Do not push down on it or lean on it.
- Handle it carefully when installing or removing.

Frame Hooks

Front

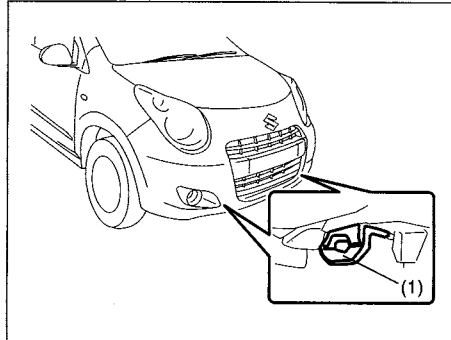

68KH063

Rear

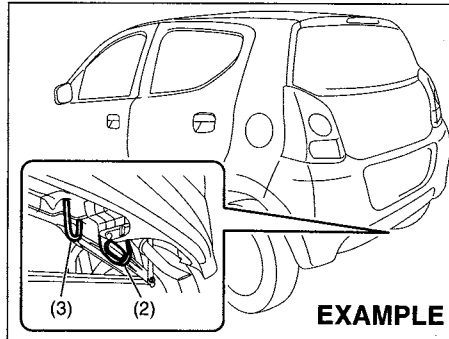

68KM081

The frame hooks are provided on the front (1), rear (2) and (3) of the vehicle. The hooks (1) and (2) are used for emergency situations. The hooks (1) and (3) are used for trailer/train shipping purpose.

To tow your vehicle on the road or highway, follow the instruction of "Towing" in "EMERGENCY SERVICE" or "VEHICLE LOADING AND TOWING" section.

⚠ WARNING

Do not use the frame hooks to tow another vehicle or to have your vehicle towed on the road or highway. The hooks (1) and (2) are designed for use in emergency situations only, such as if your vehicle or another vehicle gets stuck in deep mud or snow.

The hook (3) is provided for trailer/train shipping purposes.

CAUTION

Never use the hook (2) for trailer/train shipping purposes to prevent damage to the vehicle.

VEHICLE LOADING AND TOWING

Vehicle Loading	6-1
Trailer Towing	6-1
Towing Your Vehicle (recreational towing)	6-6

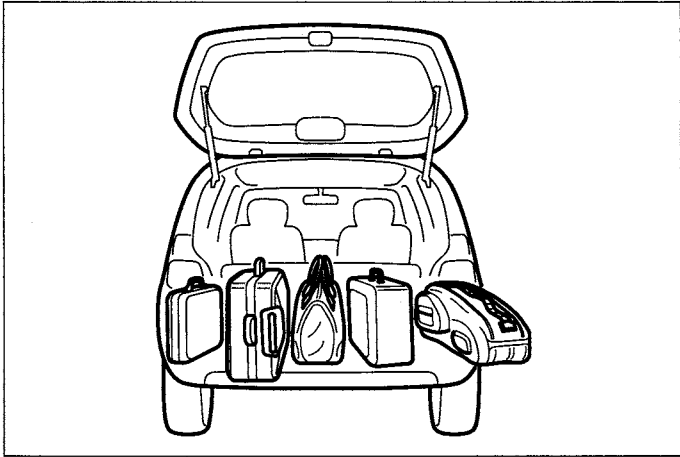

54G215

Vehicle Loading

Your vehicle was designed for specific weight capacities. The weight capacities of your vehicle are indicated by the Gross Vehicle Weight Rating (GVWR) and the Gross Axle Weight Rating (GAWR, front and rear). The GVWR and GAWR (front and rear) are listed in the "SPECIFICATIONS" section.

GVWR – Maximum permissible overall weight of the fully loaded vehicle (including all the occupants, accessories and cargo plus the trailer nose weight if towing a trailer).

GAWR – (Front and Rear) Maximum permissible weight on an individual axle.

Actual weight of the loaded vehicle and actual loads at the front and rear axles can only be determined by weighing the vehicle. Compare these weights to the GVWR and GAWR (front and rear). If the gross vehicle weight or the load on either axle exceeds these ratings, you must remove enough weight to bring the load down to the rated capacity.

WARNING

Never overload your vehicle. The gross vehicle weight (sum of the weights of the vehicle, all the occupants, accessories, cargo plus trailer nose weight if towing a trailer) must never exceed the Gross Vehicle Weight Rating (GVWR). In addition, never distribute a load so that the weight on either the front or rear axle exceeds the Gross Axle Weight Rating (GAWR).

WARNING

Always distribute cargo evenly. To avoid personal injury or damage to your vehicle, always secure cargo to prevent it from shifting if the vehicle moves suddenly. Place heavier objects on the floor and as far forward in the cargo area as possible. Never pile cargo higher than the top of the seat backs.

Trailer Towing

Your SUZUKI was originally designed to carry people and a normal amount of cargo, not to tow a trailer. SUZUKI does not recommend you use your vehicle to tow a trailer if there is not any local regulation about towing capacity permitted (for example, registered or statutory towing capacity). Towing a trailer can adversely affect handling, durability, and fuel economy.

Some countries have regulations which specifically allow trailer towing up to a specified maximum trailer weight (registered or statutory towing capacity, whichever is smaller); vehicles sold in these countries can be used to tow a light trailer, provided the trailer does not exceed the maximum trailer weight specified in the country's regulations.

If you use your SUZUKI to tow a trailer, you should always observe the requirements and recommendations in this section. If you intend to tow a trailer, it is essential to select a trailer and trailer towing equipment which are compatible. A reputable towing specialist can help you.

CAUTION

Trailer towing puts additional stress on the engine, drive train, and brakes of your vehicle. Never tow a trailer during the first 960 km (600 miles) of vehicle operation.

Tow Bars

Only use a tow bar that is designed to attach to the chassis of your vehicle, and a hitch that is designed to bolt to this bracket.

⚠ WARNING

Never use a tow bar which attaches to the axle or the bumper of your vehicle.

Safety Chains

Always attach safety chains between your vehicle and trailer. Cross safety chains under the nose of the trailer so that the nose will not drop to the road if the trailer becomes separated from the tow bar. Follow the manufacturer's recommendation for attaching safety chains. Always leave just enough slack to permit full turning. Never allow safety chains to drag on the road.

⚠ WARNING

Never attach safety chains to the bumper of your vehicle. Secure connections so that they can't come loose.

Trailer Lights

Make sure your trailer is equipped with lights which meet local requirements. Always check for the proper operation of all trailer lights before you start to tow.

⚠ WARNING

Never connect trailer lights directly into your vehicle's electrical system, or electrical system damage may occur.

Brakes**⚠ WARNING**

If trailer brakes are used, you should follow all instructions provided by the manufacturer. Never connect to the brake system of your vehicle and never take an electrical supply directly from the wiring harness.

Tires

WARNING

When towing a trailer, it is very important for your vehicle and trailer to have properly inflated tires. Your vehicle's tires should be inflated to the pressures listed on your vehicles Tire Information Label. If laden pressures are listed on the label, the tires should be inflated to the laden pressures. Inflate trailer tires according to the specifications provided by the trailer manufacturer.

Mirrors

Check to see if your vehicle's mirrors meet local requirements for mirrors used on towing vehicles. If they do not, you must install the required mirrors before you tow.

Vehicle/Trailer Loading

To load your vehicle and trailer properly, you must know how to measure gross trailer weight and trailer nose weight.

Gross Trailer Weight is the weight of the trailer plus all the cargo in it. You can measure gross trailer weight by putting the fully loaded trailer on a vehicle scale.

Nose Weight is the downward force exerted on the tow bar by the trailer coupler, with the trailer fully loaded and the coupler at its normal towing height. This weight can be measured using a bathroom scales.

The weight of your loaded trailer (Gross Trailer Weight) should never exceed the "Towing capacity".

Distribute cargo in your trailer so that nose weight is about 10% of gross trailer weight, but does not exceed "Maximum vertical load on trailer hitch point". You should measure gross trailer weight and nose weight before towing to make sure that your load is properly distributed.

WARNING

Improper weight distribution of your trailer may result in poor vehicle handling and swaying of the trailer. Always make sure that trailer nose weight is about 10% of gross trailer weight, but does not exceed "Maximum vertical load on trailer hitch point". Also make sure that the cargo is properly secured. Failure to observe this requirement may result in an accident.

WARNING

Never overload your trailer or your vehicle. Gross trailer weight must never exceed the "Towing capacity". Gross vehicle weight (sum of the weights of the vehicle, all the occupants, accessories including tow bars and a trailer hitch, cargo and trailer nose weight) must never exceed the Gross Vehicle Weight Rating (GVWR) listed in the "SPECIFICATIONS" section.

Additional Trailer Towing Warnings

⚠ WARNING

Connect trailer lights and hook up safety chains every time you tow.

CAUTION

Because towing a trailer puts additional stress on your vehicle, more frequent maintenance will be required than under normal driving conditions. Follow the schedule for "Maintenance Recommended under Severe Driving Conditions".

⚠ WARNING

Your vehicle will handle differently when towing a trailer. For your safety and the safety of others, you should observe the following precautions:

- Practice turning, stopping, and reversing before you begin towing in traffic. Do not tow in traffic until you are confident that you can handle the vehicle and trailer safely.
- Never exceed towing speed limits or 80 km/h (50 mph), whichever is lower.
- Never drive at a speed that causes shaking or swaying of the trailer. If you notice even the slightest sign of shaking or swaying, slow down.
- When roads are wet, slippery or rough, drive at a slower speed than you would on dry, smooth roads. Failure to slow down when road conditions are bad can result in loss of control.
- Always have someone guide you when reversing.
- Allow adequate stopping distance. Stopping distance is increased when you tow a trailer. For each 16 km/h (10 mph) of speed, allow at least one vehicle and trailer length between you and the vehicle ahead. Follow at a greater distance if roads are wet or slippery.

(Continued)

⚠ WARNING

(Continued)

- If the trailer has over-run brakes, apply the brakes gradually to avoid snatching caused by the trailer wheels locking.
- Slow down before corners and maintain a steady speed while cornering. Deceleration or acceleration while cornering can result in loss of control. Remember that a larger than normal turning radius is needed because the trailer wheels will be closer than vehicle wheels to the inside of the turn.
- Avoid sudden acceleration and stopping of the vehicle. Do not make quick maneuvers unless they are necessary.
- Slow down in cross winds and be prepared for gusts of wind from large passing vehicles.
- Be careful when overtaking other vehicles. Be sure to allow enough room for your trailer before you change lanes, and signal well in advance.
- Slow down and shift into a lower gear before you reach long or steep downhill grades. It is hazardous to attempt downshifting while you are descending a hill.

(Continued)

⚠ WARNING

(Continued)

- Avoid “riding” the brakes. This could cause the brakes to overheat resulting in reduced braking efficiency. Use engine braking as much as possible.
- Because of the added trailer weight, your engine may overheat on hot days when going up long or steep hills. Pay attention to your engine temperature gauge. If it indicates overheating, pull off the road and stop in a safe place. Refer to “If the Engine Overheats” in “EMERGENCY SERVICE” section.

EXAMPLE



60A186

⚠ WARNING

When parking your vehicle and connected trailer, always use the following procedure:

- 1) Apply the vehicle's brakes firmly.
- 2) Have another person place wheel chocks under the wheels of the vehicle and the trailer while you are holding the brakes.
- 3) Slowly release the brakes until the wheel chocks absorb the load.
- 4) Fully engage the parking brake.
- 5) Manual transaxle – turn off the engine, then shift into reverse or first gear.

Automatic transaxle – shift into “p” (Park) and turn off the engine.

(Continued)

⚠ WARNING

(Continued)

When starting out after parking:

- 1) Depress the clutch (if equipped) and start the engine.
- 2) Shift into gear, release the parking brake, and slowly pull away from the chocks.
- 3) Stop, apply the brakes firmly and hold them.
- 4) Have another person remove the chocks.

Trailer hitch installation points

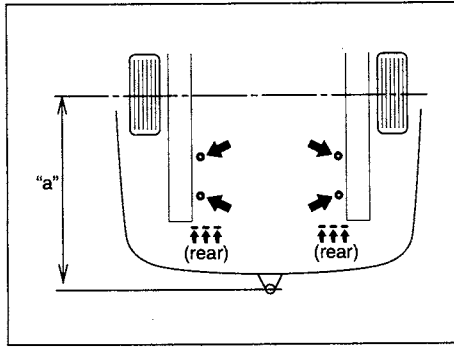

68KM088

Registered maximum vertical load on trailer hitch point (EU)
50 kg (110 lbs)

Maximum permissible overhang "a"
570 mm (22.4 in.)

Towing Your Vehicle (recreational towing)

Your vehicle may be towed behind another vehicle (such as a motorhome), provided your vehicle is 2 wheel drive (2WD) and you use the proper towing method specified for your vehicle. The towing method you must use depends on the specifications of your vehicle: whether it is a manual transaxle vehicle or an automatic transaxle vehicle.

Use the towing instruction table to select the proper towing method for your vehicle, and carefully follow the corresponding instructions. Be sure to use proper towing equipment designed for recreational towing and make sure that towing speed does not exceed 90 km/h (55 mph).

TOWING INSTRUCTION TABLE

DRIVE TRAIN	TRANSAXLE	TOWING METHOD
2WD	A/T (AUTO)	A
	M/T (MANUAL)	A B

⚠ WARNING

When you tow your vehicle, follow the instructions below to avoid accidents and damage to your vehicle. In addition, be sure to observe government and local requirements regarding vehicle lighting and trailer hitches or tow bars.

⚠ WARNING

A safety chain should always be used when you tow your vehicle.

TOWING METHOD A

FROM THE FRONT:
FRONT WHEELS ON A DOLLY
AND REAR WHEELS ON THE GROUND

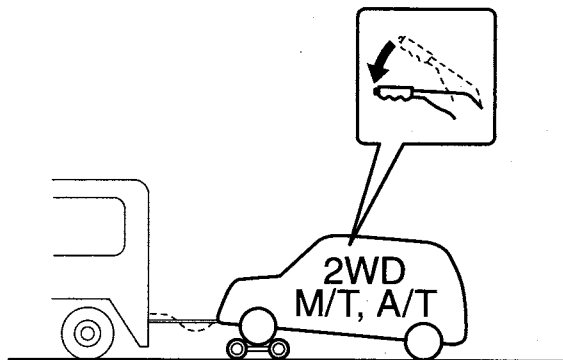

54G212

A: 2WD VEHICLES WITH MANUAL TRANSAXLE OR AUTOMATIC TRANSAXLE

- 1) Secure the front wheels on a towing dolly according to the instructions provided by the dolly manufacturer.
- 2) Release the parking brake.

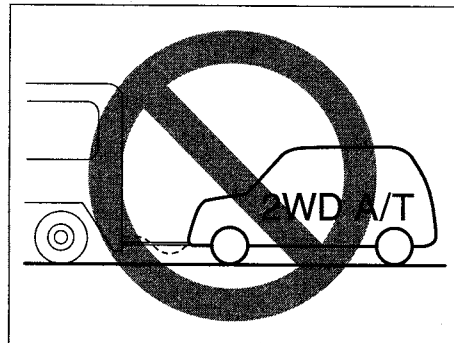

54G641

CAUTION

Towing an automatic transaxle vehicle with four wheels on the ground can result in damage to the automatic transaxle.

TOWING METHOD B

**FROM THE FRONT:
FOUR WHEELS ON THE GROUND**

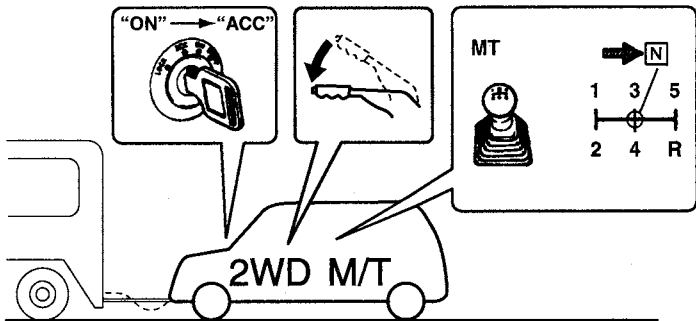

54G213

B: 2WD VEHICLES WITH MANUAL TRANSAXLE

- 1) Shift the manual transaxle lever into neutral.
- 2) Turn the ignition key to the "ACC" position to unlock the steering wheel.
- 3) Release the parking brake.

CAUTION

The steering column is not strong enough to withstand shocks transmitted from the front wheels during towing. Always unlock the steering wheel before towing.



54G642

CAUTION

Towing an automatic transaxle vehicle with four wheels on the ground can result in damage to the automatic transaxle.

MEMO

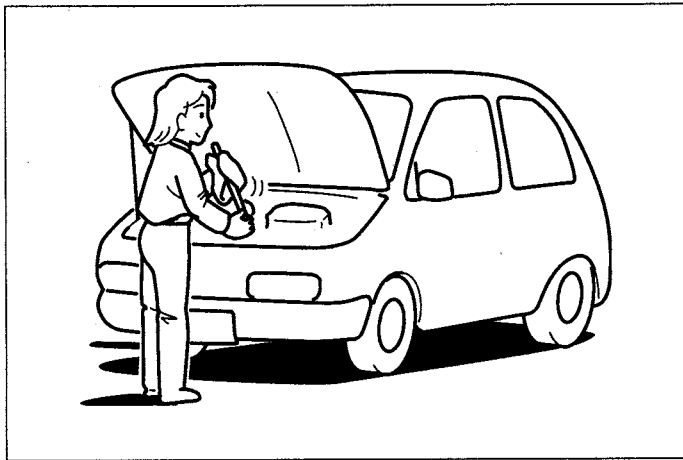

60G410

INSPECTION AND MAINTENANCE

Maintenance Schedule	7-2
Periodic Maintenance Schedule	7-2
Maintenance Recommended under Severe Driving	
Conditions	7-5
Drive Belt	7-7
Engine Oil and Filter	7-7
Engine Coolant	7-11
Air Cleaner	7-12
Spark Plugs	7-13
Gear Oil	7-14
Clutch Pedal	7-15
Automatic Transaxle (AT) Fluid	7-16
Brakes	7-17
Steering	7-19
Tires	7-19
Battery	7-22
Fuses	7-24
Bulb Replacement	7-26
Wiper Blades	7-31
Windshield Washer Fluid	7-34
Air Conditioning System	7-34

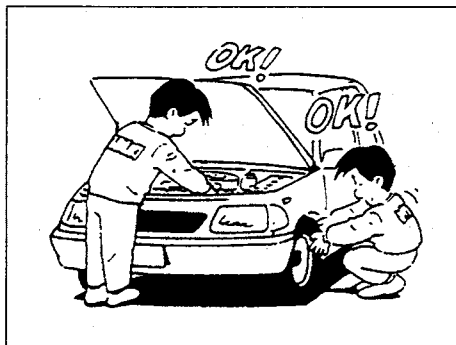

60A187S

⚠ WARNING

You should take extreme care when working on your vehicle to prevent accidental injury. Here are a few precautions that you should be especially careful to observe:

(Continued)

⚠ WARNING

(Continued)

- To prevent damage or unintended activation of the air bag system or seat belt pretensioner system, be sure the battery is disconnected and the ignition switch has been in the "LOCK" position for at least 90 seconds before performing any electrical service work on your SUZUKI. Do not touch air bag system components, seat belt pretensioner system components or wires.

The wires are wrapped with yellow tape or yellow tubing, and the couplers are yellow for easy identification.

- Do not leave the engine running in garages or other confined areas.
- When the engine is running, keep hands, clothing, tools, and other objects away from the fan and drive belt. Even though the fan may not be moving, it can automatically turn on without warning.

(Continued)

⚠ WARNING

(Continued)

- When it is necessary to do service work with the engine running, make sure that the parking brake is set fully and the transaxle is in Neutral.
- Do not touch ignition wires or other ignition system parts when starting the engine or when the engine is running, or you could receive an electric shock.
- Be careful not to touch a hot engine, exhaust manifold and pipes, muffler, radiator and water hoses.
- Do not allow smoking, sparks, or flames around fuel or the battery. Flammable fumes are present.
- Do not get under your vehicle if it is supported only with the portable jack provided in your vehicle.
- Be careful not to cause accidental short circuits between the positive and negative battery terminals.
- Keep used oil, coolant, and other fluids away from children and pets. Dispose of used fluids properly; never pour them on the ground, into sewers, etc.

Maintenance Schedule

EXAMPLE

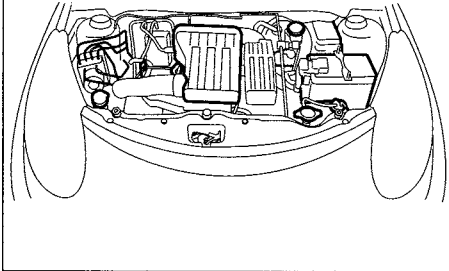

68KH064

The following table shows the times when you should perform regular maintenance on your vehicle. This table shows in miles, kilometers and months when you should perform inspections, adjustments, lubrication and other services. These intervals should be shortened if driving is usually done under severe conditions (refer to "Maintenance Recommended under Severe Driving Conditions").

⚠ WARNING

SUZUKI recommends that maintenance on items marked with an asterisk (*) be performed by your authorized SUZUKI dealer or a qualified service technician. If you are qualified, you may perform maintenance on the unmarked items by referring to the instructions in this section. If you are not sure whether you can successfully complete any of the unmarked maintenance jobs, ask your authorized SUZUKI dealer to do the maintenance for you.

CAUTION

Whenever it becomes necessary to replace parts on your vehicle, it is recommended that you use genuine SUZUKI replacement parts or their equivalent.

Periodic Maintenance Schedule

- "R" : Replace or Change
- "I" : Inspect, clean, adjust, lubricate or replace as necessary
- "L" : Lubricate

NOTE:

This table includes services as scheduled up to 90000 km (54000 miles) mileage. Beyond 90000 km (54000 miles), carry out the same services at the same intervals respectively.

INSPECTION AND MAINTENANCE

*Interval: This interval should be judged by odometer reading or months, whichever comes first.	km (x1000)	15	30	45	60	75	90
	miles (x1000)	9	18	27	36	45	54
	months	12	24	36	48	60	72
ENGINE							
1-1. Engine accessory drive belt	Tension check, *Adjustment, *Replacement	-	-	I	-	-	R
*1-2. Valve clearance		-	I	-	I	-	I
1-3. Engine oil and engine oil filter		R	R	R	R	R	R
1-4. Engine coolant		-	-	R	-	-	R
*1-5. Exhaust system (except catalyst)		-	I	-	I	-	I
IGNITION							
2-1. Spark plugs When unleaded fuel is used	Iridium plug	Replace every 105000 km (63000 miles) or 84 months.					
	Spark plugs When leaded fuel is used, refer to "Severe Driving Condition" schedule.						
FUEL							
3-1. Air cleaner filter element	Paved-road	I	I	R	I	I	R
	Dusty condition	Refer to "Severe Driving condition" schedule					
*3-2. Fuel lines		-	I	-	I	-	I
*3-3. Fuel tank		-	-	I	-	-	I
EMISSION CONTROL SYSTEM							
*4-1. PCV valve		-	-	-	-	-	I
*4-2. Fuel evaporative emission control system		-	-	-	-	-	I

INSPECTION AND MAINTENANCE

*Interval: This interval should be judged by odometer reading or months, whichever comes first.	km (x1000)	15	30	45	60	75	90
	miles (x1000)	9	18	27	36	45	54
	months	12	24	36	48	60	72
BRAKE							
*5-1. Brake discs and pads (front)							
Brake drums and shoes (rear)		-		-		-	
*5-2. Brake hoses and pipes		-		-		-	
5-3. Brake fluid	Check, *Replacement	-	R	-	R	-	R
5-4. Brake lever and cable	Check, *Adjustment (1st 15000 km only)		-	-	-	-	-
CHASSIS AND BODY							
*6-1. Clutch pedal [Cable control type]		-		-		-	
6-2. Tires/Wheels							
*6-3. Drive axle boots		-	-		-	-	
*6-4. Suspension system		-		-		-	
*6-5. Steering system		-		-		-	
*6-6. Manual transaxle oil	(! 1st 15000 km only)		-	R	-	-	R
6-7. Automatic transaxle	Fluid level	-		-		-	
	*Fluid change	Replace every 165000 km (99000 miles).					
	*Fluid hose	-	-	-		-	-
6-8. All latches, hinges and locks		-		-		-	
*6-9. Air conditioner filter element (if equipped)		-		R	-		R

⚠ WARNING

The shock absorbers are filled with high pressure gas. Never attempt to disassemble them or throw them into a fire. Avoid storing them near a heater or heating device. When scrapping the absorber, the gas must be released from the absorber safely. Ask your dealer for assistance.

INSPECTION AND MAINTENANCE

Maintenance Recommended under Severe Driving Conditions

If the car is usually used under the conditions corresponding to any severe condition code given below, it is recommended that applicable maintenance operation be performed at the particular interval as given in the chart below.

Severe condition code

A – Repeated short trips

B – Driving on rough and/or muddy roads

C – Driving on dusty roads

D – Driving in extremely cold weather and/or salted roads

E – Repeated short trips in extremely cold weather

F – Leaded fuel use

G – _____

H – Trailer towing (if admitted)

Severe Condition Code	Maintenance		Maintenance Operation	Maintenance Interval
- B C D - - - -	Engine accessory drive belt		I	Every 15000 km (9000 miles) or 12 months
			R	Every 45000 km (27000 miles) or 36 months
A - C D E F - H	Engine oil and oil filter		R	Every 7500 km (4500 miles) or 6 months
A B C - E F - H	Spark plugs	Iridium plug	R	Every 30000 km (18000 miles) or 24 months

Severe Condition Code	Maintenance	Maintenance Operation	Maintenance Interval
- - C - - - - -	Air cleaner filter element (Inspect or replace more frequently if necessary.)	I	Every 2500 km (1500 miles)
		R	Every 30000 km (18000 miles) or 24 months
- B - - E - - H	Automatic transaxle fluid change	R	Every 30000 km (18000 miles) or 24 months
- B C D - - - H	Wheel bearings	I	Every 15000 km (9000 miles) or 12 months
- B - D E - - H	Drive axle boots	I	Every 15000 km (9000 miles) or 12 months
- B - - E - - H	Manual transaxle oil	R	First time only: 15000 km (9000 miles) or 12 months
			Second time and after: Every 30000 km (18000 miles) or 24 months reckoning from 0 km (0 mile) or 0 month
- - C D - - - -	Air conditioner filter element (if equipped) (Clean more frequently if the air flow from the air conditioner decreases.)	I	Every 15000 km (9000 miles) or 12 months
		R	Every 45000 km (27000 miles) or 36 months

NOTE:

I – Inspect, clean, adjust, lubricate or replace as necessary

R – Replace or change

T – Tighten to the specified torque

Drive Belt

⚠ WARNING

When the engine is running, keep hands, hair, clothing, tools, etc. away from the moving fan and drive belts.

Make sure the drive belt tension is correct. If the belt is too loose, insufficient battery charging, engine overheating, poor power steering, poor air conditioning, or excessive belt wear can result. When you press the belt with your thumb midway between the pulleys, there should be a deflection according to the following chart.

The belts should also be examined to ensure that they are not damaged.

If you need to replace or adjust the belt have it done by your SUZUKI dealer.

K10B

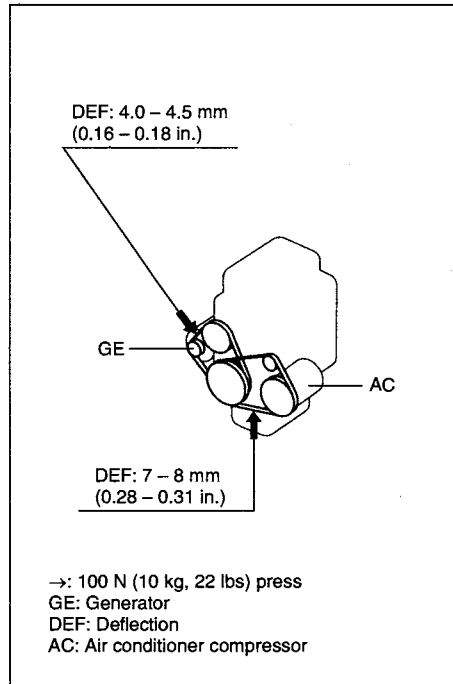

51KM036

Engine Oil and Filter

Specified Oil

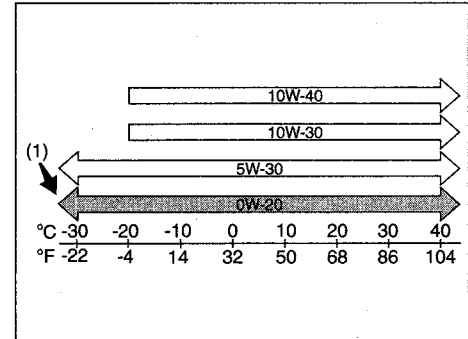

63J266

(1) Preferred

Be sure that the engine oil you use comes under the quality classification of SG, SH, SJ, SL or SM. Select the appropriate oil viscosity according to the above chart.

SAE 0W-20 is the best choice for good fuel economy, and good starting in cold weather.

Oil Level Check

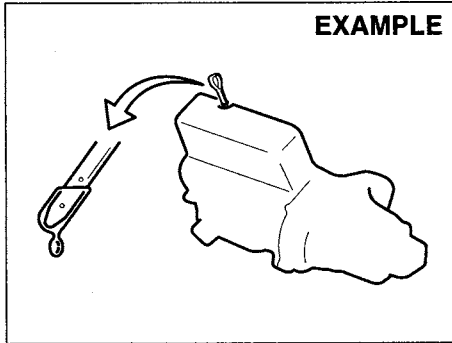

It is important to keep the engine oil at the correct level for proper lubrication of your vehicle's engine. Check the oil level with the vehicle on a level surface. The oil level indication may be inaccurate if the vehicle is on a slope. The oil level should be checked either before starting the engine or at least 5 minutes after stopping the engine.

The handle of the engine oil dipstick is colored yellow for easy identification. Pull out the oil dipstick, wipe oil off with a clean cloth, insert the dipstick all the way into the engine, then remove it again. The oil on the stick should be between the upper and lower limits shown on the stick. If the oil level indication is near the lower limit, add enough oil to raise the level to the upper limit.

CAUTION

Failure to check the oil level regularly could lead to serious engine trouble due to insufficient oil.

Refilling

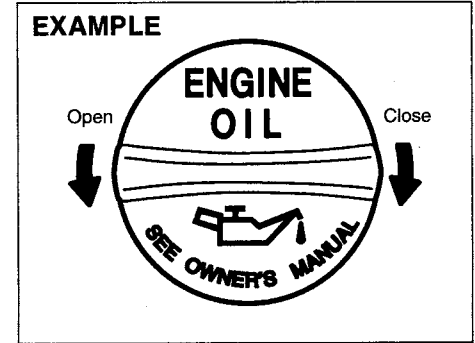

Remove the oil filler cap and pour oil slowly through the filler hole to bring the oil level to the upper limit on the dipstick. Be careful not to overfill. Too much oil is almost as bad as too little oil. After refilling, start the engine and allow it to idle for about a minute. Stop the engine, wait about 5 minutes and check the oil level again.

INSPECTION AND MAINTENANCE

Changing Engine Oil and Filter

Drain the engine oil while the engine is still warm.

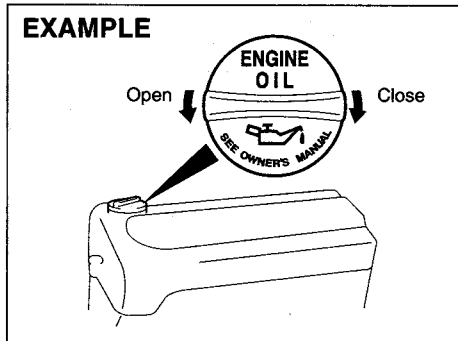

- 1) Remove the oil filler cap.
- 2) Place a drain pan under the drain plug.
- 3) Using a wrench, remove the drain plug and drain out the engine oil.

⚠ WARNING

The engine oil temperature may be high enough to burn your fingers when the drain plug is loosened. Wait until the drain plug is cool enough to touch with your bare hands.

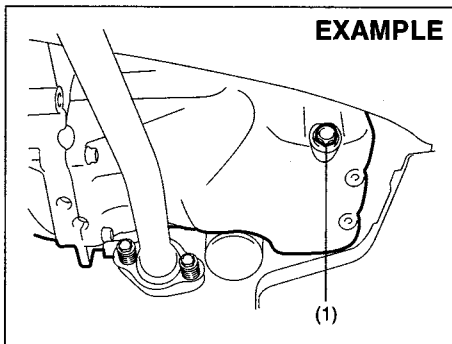

**Tightening torque for drain plug (1):
35 Nm (3.5 kg-m, 25.5 lb-ft)**

⚠ WARNING

New and used oil can be hazardous. Children and pets may be harmed by swallowing new or used oil. Keep new and used oil and used oil filters away from children and pets.

Repeated, prolonged contact with used engine oil may cause skin cancer.

Brief contact with used oil may irritate skin.

(Continued)

⚠ WARNING

(Continued)

To minimize your exposure to used oil, wear a long-sleeve shirt and moisture-proof gloves (such as dish-washing gloves) when changing oil. If oil contacts your skin, wash thoroughly with soap and water.

Launder any clothing or rags if wet with oil.

Recycle or properly dispose of used oil and filters.

- 4) Reinstall the drain plug and gasket. Tighten the plug with a wrench to the specified torque.

Replace the Oil Filter

- 1) Using an oil filter wrench, turn the oil filter counterclockwise and remove it.
- 2) Using a clean rag, wipe off the mounting surface on the engine where the new filter will be seated.
- 3) Smear a little engine oil around the rubber gasket of the new oil filter.
- 4) Screw on the new filter by hand until the filter gasket contacts the mounting surface.

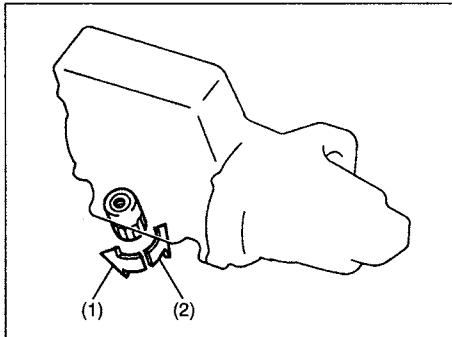

54G092

- (1) Loosen
- (2) Tighten

CAUTION

To tighten the oil filter properly, it is important to accurately identify the position at which the filter gasket first contacts the mounting surface.

- 5) Tighten the filter specified turn from the point of contact with the mounting surface (or to the specified torque) using an oil filter wrench by following the instruction indicated on the filter.

CAUTION

To prevent oil leakage, make sure that the oil filter is tight, but do not over-tighten it.

Refill with Oil and Check for Leaks

- 1) Pour oil through the filler hole and install the filler cap.
For the approximate capacity of the oil, refer to the "CAPACITIES" item in the "SPECIFICATIONS" section.
- 2) Start the engine and look carefully for leaks at the oil filter and drain plug. Run the engine at various speeds for at least 5 minutes.
- 3) Stop the engine and wait about 5 minutes. Check the oil level again and add oil if necessary. Check for leaks again.

CAUTION

- **When replacing the oil filter, it is recommended that you use a genuine SUZUKI replacement filter. If you use an aftermarket filter, make sure it is of equivalent quality and follow the manufacturer's instructions.**
- **Oil leaks from around the oil filter or drain plug indicate incorrect installation or gasket damage. If you find any leaks or are not sure that the filter has been properly tightened, have the vehicle inspected by your SUZUKI dealer.**

Engine Coolant

Selection of Coolant

To maintain optimum performance and durability of your engine, use SUZUKI Genuine Coolant or equivalent.

This type of coolant is best for your cooling system as it:

- Helps maintain proper engine temperature.
- Gives proper protection against freezing and boiling.
- Gives proper protection against corrosion and rust.

Failure to use the proper coolant can damage your cooling system. Your authorized SUZUKI dealer can help you select the proper coolant.

CAUTION

To avoid damaging your cooling system:

- **Always use a high quality ethylene glycol base non-silicate type coolant diluted with distilled water at the correct mixture concentration.**
- **Make sure that the proper mix is 50/50 coolant to distilled water and in no case higher than 70/30. Concentrations greater than 70/30 coolant to distilled water will cause overheating conditions.**
- **Do not use straight coolant nor plain water.**
- **Do not add extra inhibitors or additives. They may not be compatible with your cooling system.**
- **Do not mix different types of base coolants. Doing so may result in accelerated seal wear and/or the possibility of severe overheating and extensive engine/automatic transaxle damage.**

Coolant Level Check

Check the coolant level at the reservoir tank, not at the radiator. With the engine cool, the coolant level should be between the "FULL" and "LOW" marks.

Adding Coolant

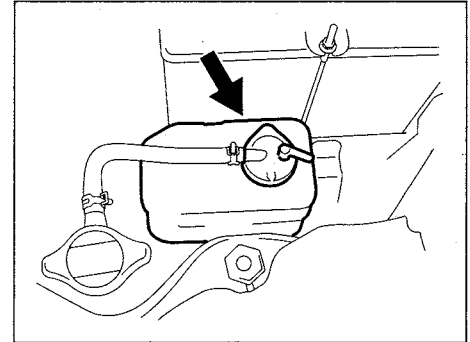

68KH069

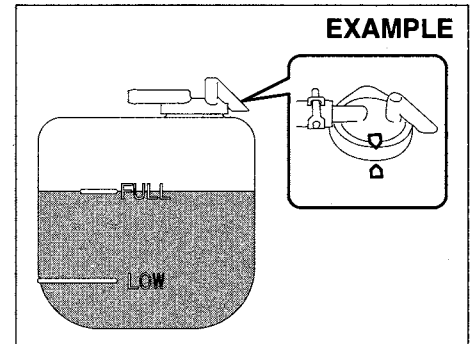

68KH070

If the coolant level is below the "LOW" mark, more coolant should be added. Remove the reservoir tank cap and add coolant until the reservoir tank level

reaches the "FULL" mark. Never fill the reservoir tank above the "FULL" mark.

⚠ WARNING

Engine coolant is harmful or fatal if swallowed or inhaled. Do not drink antifreeze or coolant solution. If swallowed, do not induce vomiting. Immediately contact a poison control center or a physician. Avoid inhaling mist or hot vapors; if inhaled, remove to fresh air. If coolant gets in eyes, flush eyes with water and seek medical attention. Wash thoroughly after handling. Solution can be poisonous to animals. Keep out of the reach of children and animals.

CAUTION

- The mixture you use should contain 50% concentration of anti-freeze.
- If the lowest ambient temperature in your area is expected to be -35°C (-31°F) or below, use higher concentrations up to 60% following the instructions on the antifreeze container.

CAUTION

When putting the cap on the reservoir tank, line up the mark on the cap and the mark on the tank. Failure to follow this can result in coolant leakage.

Coolant Replacement

Since special procedures are required, we recommend you take your vehicle to your SUZUKI dealer for coolant replacement.

Air Cleaner

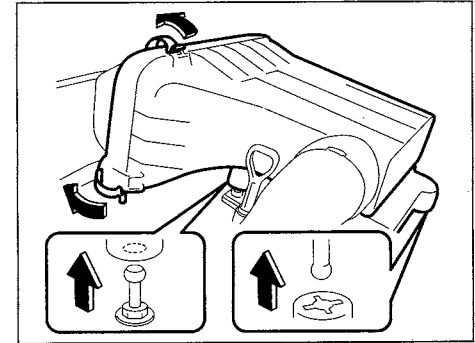

68KH071

If the air cleaner is clogged with dust, there will be greater intake resistance, resulting in decreased power output and increased fuel consumption.

Unclamp the upper and side clamps, and remove the element from the air cleaner case. If it appears to be dirty, replace it with a new one.

Spark Plugs

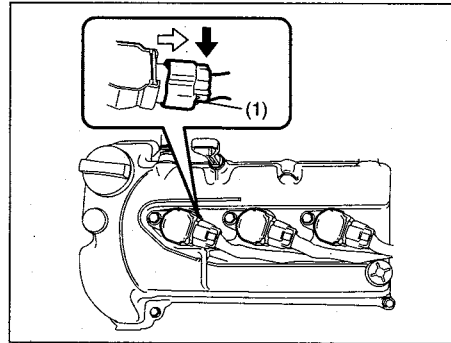
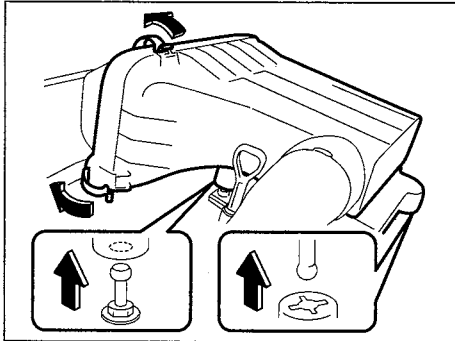

You should inspect spark plugs periodically for carbon deposits. When carbon accumulates on a spark plug, a strong spark may not be produced. Remove carbon deposits with a wire or pin and adjust the spark plug gap.

To access the spark plugs:

- 1) Unclamp and remove the air cleaner case.
- 2) If necessary, disconnect the coupler (1) while pushing the release lever.
- 3) Remove the ignitor bolts.
- 4) Pull the spark plug boots out.

NOTE:

When installation, make sure the wires, couplers, sealing rubber of top cover and washers, are correctly returned in place.

EXAMPLE

Correct

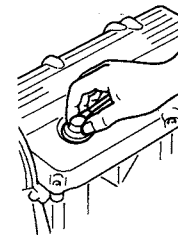

Wrong

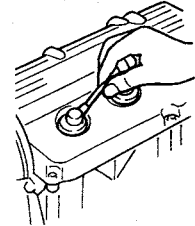

60G102

CAUTION

- When disconnecting the spark plug cables, pull on the boot, not on the cable itself. Pulling on the cable can damage it.
- When servicing the iridium/platinum spark type plugs (slender center electrode type plugs), do not touch the center electrode, as it is easy to damage.

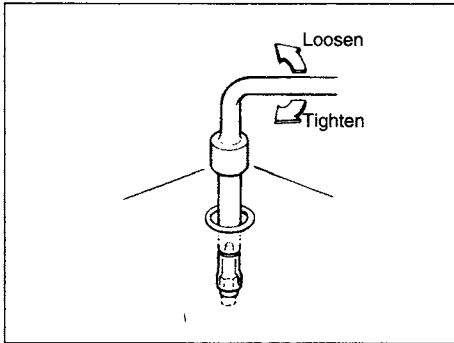

60G160S

CAUTION

- When installing the spark plugs, screw them in with your fingers to avoid stripping the threads. Tighten with a torque wrench to 25 Nm (2.5 kg-m, 18.0 lb-ft). Do not allow contaminants to enter the engine through the spark plug holes when the plugs are removed.
- Never use spark plugs with the wrong thread size.

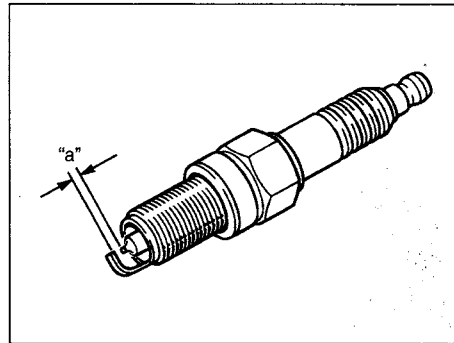

54G106

Spark plug gap "a"
 NGK IKR6G11:
 1.0 – 1.1 mm (0.039 – 0.043 in.)

CAUTION

When replacing spark plugs, you should use the brand and type specified for your vehicle. For the specified plugs, refer to the "SPECIFICATIONS" section at the end of this book. If you wish to use a brand of spark plug other than the specified plugs, consult your SUZUKI dealer.

Gear Oil

Manual Transaxle Oil

When adding gear oil, use gear oil with the appropriate viscosity and grade. We highly recommend you use: SUZUKI GEAR OIL 75W-90 for manual transaxle oil.

Manual transaxle oil (API GL-4)

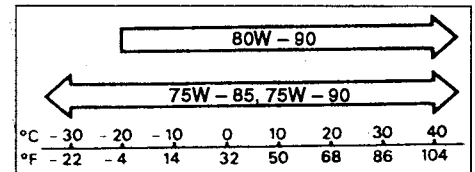

54G095

Gear Oil Level Check

Manual transaxle

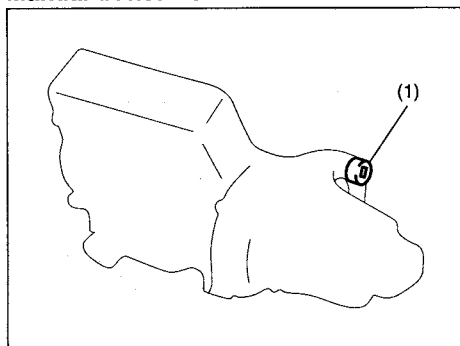

68KH073

(1) Oil filler and level plug

To check the gear oil level, use the following procedure:

- 1) Park the vehicle on a level surface with the parking brake applied. Then, stop the engine.
- 2) Remove the oil filler plug (1).
- 3) Check the inside of the hole with your finger. If the oil level comes up to the bottom of the plug hole, the oil level is correct. If so, reinstall the plug.

- 4) If the oil level is low, add gear oil through the oil filler plug hole (1) until the oil level reaches the bottom of the filler hole, then reinstall the plug.

Tightening torque (1) :
21 Nm (2.1 kg-m, 15.5 lb-ft)

⚠ WARNING

After driving the vehicle, the transaxle oil temperature may be high enough to burn your skin. Wait until the oil filler plug is cool enough to touch with your bare hands before inspecting transaxle oil.

CAUTION

When tightening the plug, apply the following sealing compound or equivalent to the plug threads to prevent oil leakage.

Manual transaxle sealant:
SUZUKI Bond No. "1217G"

Gear Oil Change

Since special procedures, materials and tools are required, it is recommended that you trust this job to your authorized SUZUKI dealer.

Clutch Pedal

Cable control clutch (if equipped)

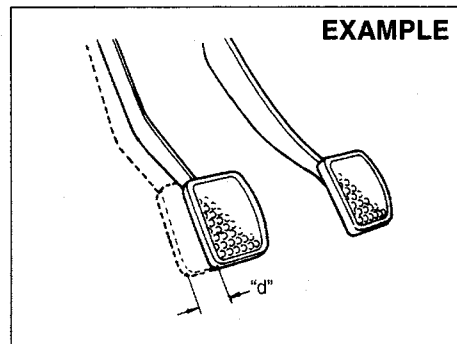

54G274

Clutch pedal play "d":
10 - 15 mm (0.4 - 0.6 in.)

Measure the clutch pedal play by moving the clutch pedal with your hand and measuring the distance it moves until you feel slight resistance. The play in the clutch pedal should be between the specified values. If the play is more or less than the above, or clutch dragging is felt with the pedal fully depressed, have the clutch inspected by your SUZUKI dealer.

Automatic Transaxle (AT) Fluid

Specified Fluid

Use an automatic transaxle:
SUZUKI ATF 3317 or Mobil ATF 3309

Fluid Level Check

CAUTION

Driving with too much or too little fluid can damage the transaxle.

You must check the fluid level with the automatic transaxle fluid at normal operating temperature.

To check the fluid level:

- 1) To warm up the transaxle fluid, drive the vehicle for 20 more minutes.

CAUTION

Be sure to use the specified automatic transaxle fluid. Using automatic transaxle fluid other than SUZUKI ATF 3317 or Mobil ATF 3309 may damage the automatic transaxle of your vehicle.

NOTE:

Do not check the fluid level if you have just driven the vehicle for a long time at high speed, if you have driven in city traffic in hot weather, or if the vehicle has been pulling a trailer. Wait until the fluid cools down (about 30 minutes), or the fluid level indication will not be correct.

EXAMPLE

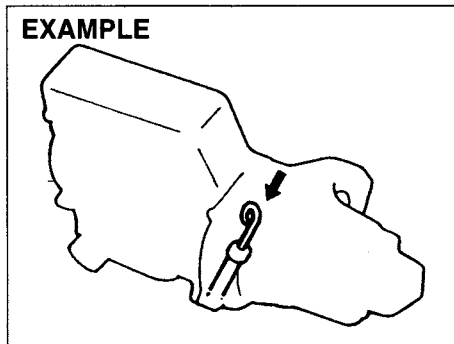

63J125

- 2) Park your vehicle on level ground.
- 3) Apply the parking brake and then start the engine in "P" (Park). Let it idle for two minutes and keep it running during the fluid level check.
- 4) With your foot on the brake pedal, move the gearshift lever through each range, pausing for about three seconds in each range. Then move it back to the "P" (Park) position.

⚠ WARNING

Be sure to depress the brake pedal when moving the gearshift lever, or the vehicle can move suddenly.

EXAMPLE

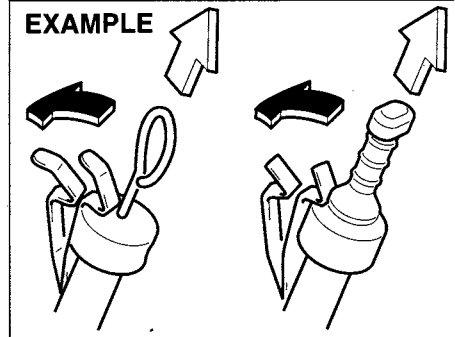

52KM144

- 5) The handle of the A/T fluid dipstick is colored red for easy identification. Remove the dipstick, clean it and push it back in until the cap seats. Then pull out the dipstick.
- 6) Check both sides of the dipstick, and read the lowest level. The fluid level should be between the two marks in the "HOT" range on the dipstick.

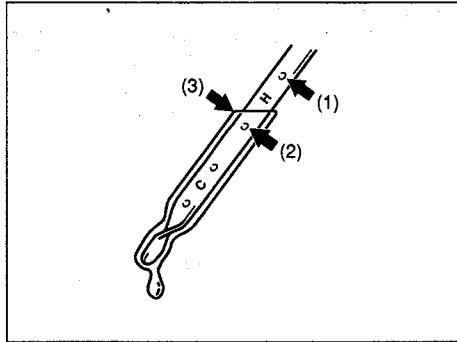

63J087

- (1) FULL HOT
- (2) LOW HOT
- (3) The lowest point = Fluid level

- 7) Add just enough specified fluid through the dipstick hole to fill the transaxle to the proper level.

CAUTION

After checking or adding oil, be sure to insert the dipstick securely.

Changing Oil

Since special procedures, materials, and tools are required to change the automatic transaxle oil, it is recommended that you trust this job to your authorized SUZUKI dealer.

Brakes

Brake Fluid

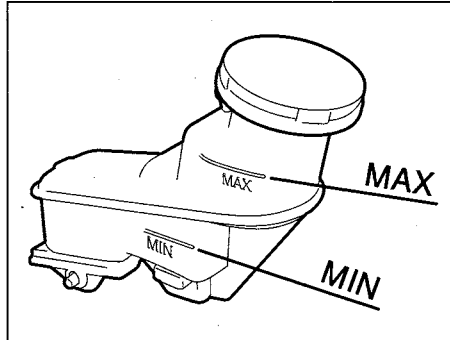

68KH074

Check the brake fluid level by looking at the reservoir in the engine compartment. Check that the fluid level is between the "MAX" and "MIN" lines. If the brake fluid level is near the "MIN" line, fill it up to the "MAX" line with DOT3 (SAE J1703) or DOT4 (SAE J1704) brake fluid.

⚠ WARNING

Failure to follow the guidelines below can result in personal injury or serious damage to the brake system.

- If the brake fluid in the reservoir drops below a certain level, the brake warning light on the instrument panel will come on (the engine must be running with the parking brake fully disengaged). Should the light come on, immediately ask your SUZUKI dealer to inspect the brake system.
 - A rapid fluid loss indicates a leak in the brake system which should be inspected by your SUZUKI dealer immediately.
 - Brake fluid can harm your eyes and damage painted surfaces. Use caution when refilling the reservoir.
- 1) Do not use any fluid other than DOT3 (SAE J1703) or DOT4 (SAE J1704) brake fluid. Do not use reclaimed fluid or fluid that has been stored in old or open containers. It is essential that foreign particles and other liquids are kept out of the brake fluid reservoir.

⚠ WARNING

Brake fluid is harmful or fatal if swallowed, and harmful if it comes in contact with skin or eyes. If swallowed, do not induce vomiting. Immediately contact a poison control center or a physician. If brake fluid gets in eyes, flush eyes with water and seek medical attention. Wash thoroughly after handling. Solution can be poisonous to animals. Keep out of the reach of children and animals.

NOTE:

With disc brakes, the fluid level can be expected to gradually fall as the brake pads wear.

Brake Pedal

Check if the brake pedal stops at the regular height without “spongy” feeling when you depress it. If not, have the brake system inspected by your SUZUKI dealer. If you doubt the brake pedal for the regular height, check it as follows:

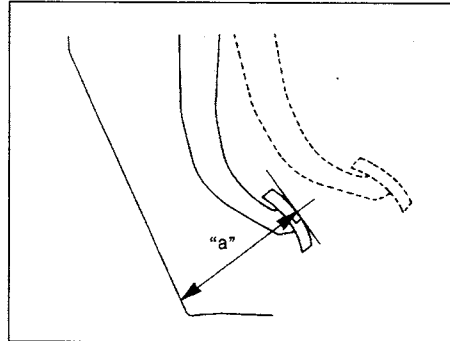

54G108

Pedal to floor carpet minimum distance “a”:

- Right hand drive: 61 mm (2.4 in.)
- Left hand drive: 70 mm (2.8 in.)

With the engine running, measure the distance between the brake pedal and floor carpet when the pedal is depressed with approximately 30 kg (66 lbs) of force. The minimum distance required is as specified. Since your vehicle's brake system is self-adjusting, there is no need for pedal adjustment.

If the pedal to floor carpet distance as measured above is less than the minimum distance required, have your vehicle inspected by your SUZUKI dealer.

NOTE:

When measuring the distance between the brake pedal and floor wall, be sure not to include the floor mat or rubber on the floor wall in your measurement.

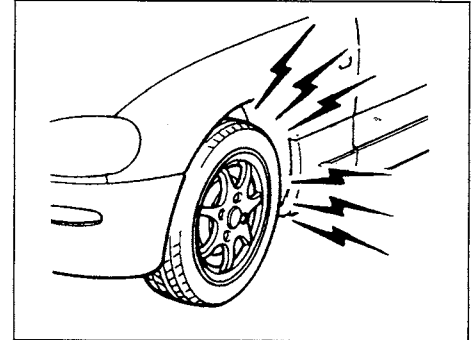

60G104S

⚠ WARNING

If you experience any of the following problems with your vehicle's brake system, have the vehicle inspected immediately by your SUZUKI dealer.

- Poor braking performance
- Uneven braking (brakes not working uniformly on all wheels.)
- Excessive pedal travel
- Brake dragging
- Excessive noise
- Pedal pulsation (pedal pulsates when depressed.)

INSPECTION AND MAINTENANCE

Parking Brake

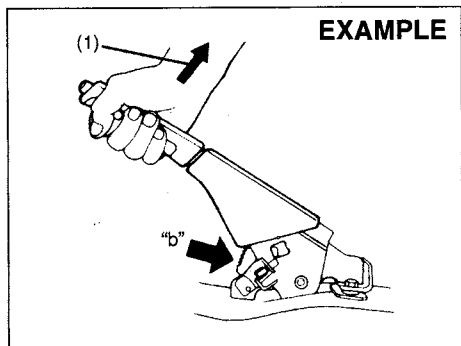

54G109

Ratchet tooth specification "b":
4th – 9th
Lever pull force (1):
200 N (20 kg, 44 lbs)

Check the parking brake for proper adjustment by counting the number of clicks made by the ratchet teeth as you slowly pull up on the parking brake lever to the point of full engagement. The parking brake lever should stop between the specified ratchet teeth and the rear wheels should be securely locked. If the parking brake is not properly adjusted or the brakes drag after the lever has been fully released, have the parking brake inspected and/or adjusted by your SUZUKI dealer.

Steering

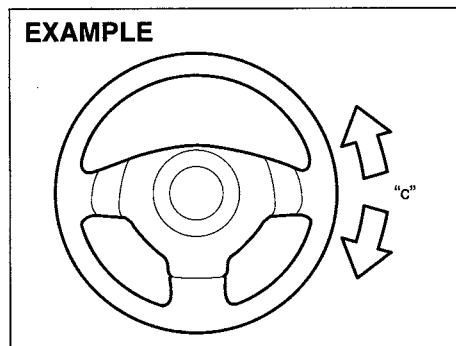

63J264

Steering wheel play "c":
0 – 30 mm (0.0 – 1.2 in.)

Check the play of the steering wheel by gently turning it from left to right and measuring the distance that it moves before you feel slight resistance. The play should be between the specified values.

Check that the steering wheel turns easily and smoothly without rattling by turning it all the way to the right and to the left while driving very slowly in an open area. If the amount of free play is outside the specification or you find anything else to be wrong, an inspection must be performed by your SUZUKI dealer.

Tires

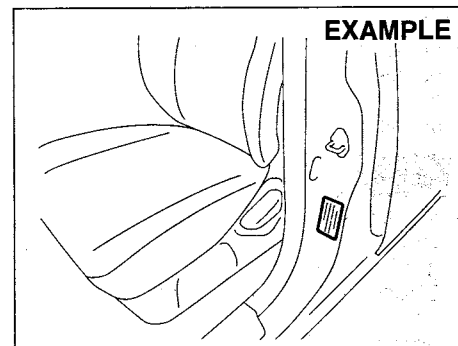

54G307

The front and rear tire pressure specifications for your vehicle are listed on the Tire Information Label. Both the front and rear tires should have the specified tire pressure.

Note that the value does not apply to the compact spare tire, if equipped.

Tire Inspection

Inspect your vehicle's tires at least once a month by performing the following checks:

- 1) Measure the air pressure with a tire gauge. Adjust the pressure if necessary. Remember to check the spare tire, too.

⚠ WARNING

- Air pressures should be checked when the tires are cold or you may get inaccurate readings.
- Check the inflation pressure from time to time while inflating the tire gradually, until the specified pressure is obtained.
- Never underinflate or overinflate the tires.
Underinflation can cause unusual handling characteristics or can cause the rim to slip on the tire bead, resulting in an accident or damage to the tire or rim.
Overinflation can cause the tire to burst, resulting in personal injury.
Overinflation can also cause unusual handling characteristics which may result in an accident.

EXAMPLE

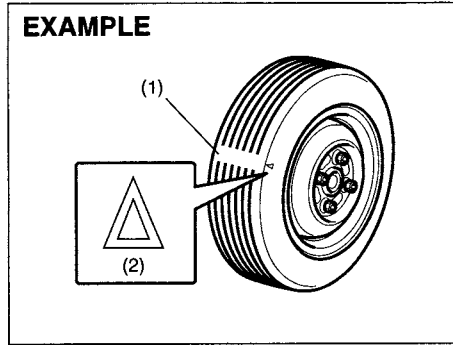

- (1) Tread wear indicator
- (2) Indicator location mark

- 2) Check that the depth of the tread groove is more than 1.6 mm (0.06 in.). To help you check this, the tires have molded-in tread wear indicators in the grooves. When the indicators appear on the tread surface, the remaining depth of the tread is 1.6 mm (0.06 in.) or less and the tire should be replaced.
- 3) Check for abnormal wear, cracks and damage. Any tires with cracks or other damage should be replaced. If any tires show abnormal wear, have them inspected by your SUZUKI dealer.

⚠ WARNING

Hitting curbs and running over rocks can damage tires and affect wheel alignment. Be sure to have tires and wheel alignment checked periodically by your SUZUKI dealer.

- 4) Check for loose wheel nuts.
- 5) Check that there are no nails, stones or other objects sticking into the tires.

⚠ WARNING

- Your SUZUKI is equipped with tires which are all the same type and size. This is important to ensure proper steering and handling of the vehicle. Never mix tires of different size or type on the four wheels of your vehicle. The size and type of tires used should be only those approved by SUZUKI as standard or optional equipment for your vehicle.
- Replacing the wheels and tires equipped on your vehicle with certain combinations of aftermarket wheels and tires can significantly change the steering and handling characteristics of your vehicle.
- Therefore, use only those wheel and tire combinations approved by SUZUKI as standard or optional equipment for your vehicle.

CAUTION

Replacing the original tires with tires of a different size may result in false speedometer or odometer readings. Check with your SUZUKI dealer before purchasing replacement tires that differ in size from the original tires.

Tire Rotation

4-tire rotation

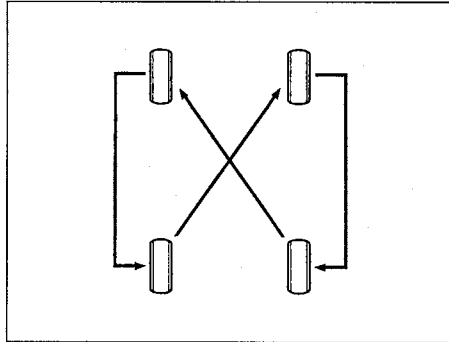

54G114

To avoid uneven wear of your tires and to prolong their life, rotate the tires as illustrated. Tires should be rotated every 10000 km (6000 miles). After rotation, adjust front and rear tire pressures to the specification listed on your vehicle's Tire Information Label.

Compact Spare Tire (if equipped)

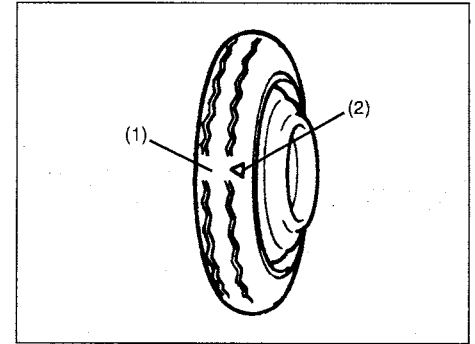

54G115

- (1) Wear indicator
- (2) Indicator location mark

Your vehicle comes equipped with the compact spare tire. The compact spare is designed to save space in your storage area, and its lighter weight makes it easier to install if a flat tire occurs. It is only intended for temporary emergency use, until the conventional tire can be repaired or replaced. The inflation pressure of the compact spare tire should be checked at least monthly. Use a quality pocket-type inflation pressure gauge and set at 420 kPa (60 psi). At the same time, check that the tire is stored securely. If it is not, tighten it.

Note that two or more compact spare tires should not be used on one vehicle simultaneously.

⚠ WARNING

The compact spare tire and wheel are intended for temporary emergency use only. Continuous use of this spare can result in tire failure and loss of control. Always observe these precautions when using this spare:

- Your vehicle will handle differently with this temporary spare.
- Do not exceed 80 km/h (50 mph) speed.
- Replace this spare with a standard tire and wheel as soon as possible.
- Use of this spare will reduce ground clearance.
- Recommended air pressure for this spare is 420 kPa (60 psi).
- Do not use tire chains on the compact spare. If you must use tire chains, rearrange the wheels so standard tires and wheels are fitted to the front axle.
- The compact spare tire has a much shorter tread life than the conventional tires on your vehicle. Replace the tire as soon as the tread wear indicator appears.
- When replacing the compact spare tire, use a replacement tire with the exact same size and construction.

Battery

⚠ WARNING

- Batteries produce flammable hydrogen gas. Keep flames and sparks away from the battery or an explosion may occur. Never smoke when working in the vicinity of the battery.
- When checking or servicing the battery, disconnect the negative cable. Be careful not to cause a short circuit by allowing metal objects to contact the battery posts and the vehicle at the same time.
- To avoid harm to yourself or damage to your vehicle or battery, follow the jump starting instructions in the “EMERGENCY SERVICE” section of this manual if it is necessary to jump start your vehicle.

EXAMPLE (traditional type)

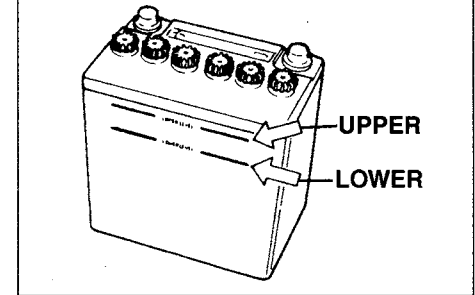

54G118

For maintenance-free battery (cap-less type), you need not add water. For traditional type battery, which has water filler caps, the level of the battery solution must be kept between the “UPPER” and the “LOWER” level lines at all times. If the level is found to be below the “LOWER” level line, add distilled water to the “UPPER” level line. You should periodically check the battery, battery terminals, and battery hold-down bracket for corrosion. Remove corrosion using a stiff brush and ammonia mixed with water, or baking soda mixed with water. After removing corrosion, rinse with clean water.

If your vehicle is not going to be driven for a month or longer, disconnect the cable from the negative terminal of the battery to help prevent discharge.

INSPECTION AND MAINTENANCE

Replacement of the battery

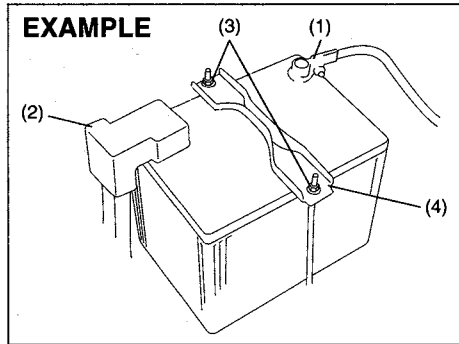

To remove the battery:

- 1) Disconnect the negative cable (1).
- 2) Disconnect the positive cable (2).
- 3) Remove the retainer nuts (3) and remove the retainer (4).
- 4) Remove the battery.

To install the battery:

- 1) Install the battery in the reverse order of removal.
- 2) Tighten the retainer nuts and battery cables securely.

NOTE:

When the battery is disconnected, some of the vehicle's function will be initialized and/or deactivated.

These function are required to reset after the battery is reconnected.

⚠ WARNING

Batteries contain toxic substances including sulfuric acid and lead. They could have potential negative consequences for the environment and human health. Used battery must be disposed or recycled according to the local law and must not be discarded with ordinary household waste. Make sure not to tip over the battery when you remove it from the vehicle. Otherwise, sulfuric acid could run out and you might get injury.

(Battery label)

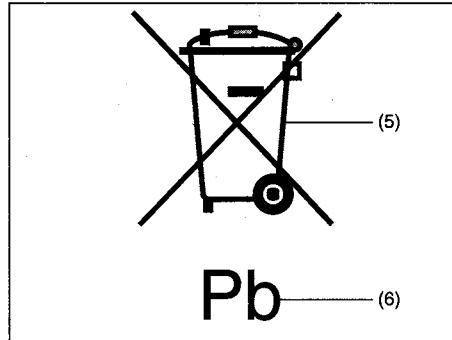

- (5) Crossed-out wheeled bin symbol
(6) Chemical symbol of "Pb"

The crossed-out wheeled bin symbol (5) located on the battery label indicates that used battery should be collected separately from ordinary household trash. The chemical symbol of "Pb" (6) indicates the battery contains more than 0.004% lead.

By ensuring the used battery is disposed or recycled correctly, you will help prevent potential negative consequences for the environment and human health, which could otherwise be caused by inappropriate trash handling of the battery. The recycling of materials will help to conserve natural resources. For more detailed information about disposing or recycling of the used battery, consult your SUZUKI dealer.

Fuses

Your vehicle has three types of fuses, as described below:

Main fuse

The main fuse takes current directly from the battery.

Primary fuses

These fuses are between the main fuse and individual fuses, and are for electrical load groups.

Individual fuses

These fuses are for individual electrical circuits.

To remove a fuse, use the fuse puller provided in the fuse box.

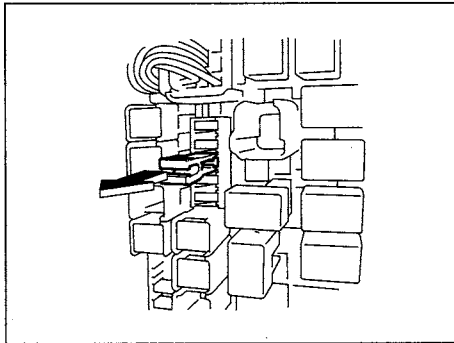

63J095

Fuses in the Engine Compartment

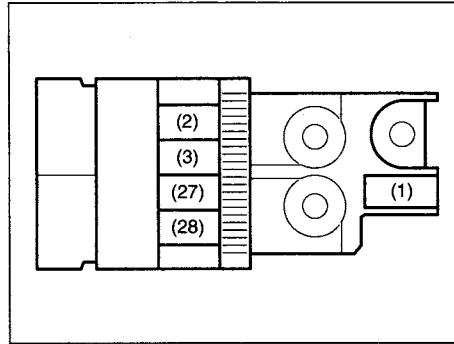

68KH076

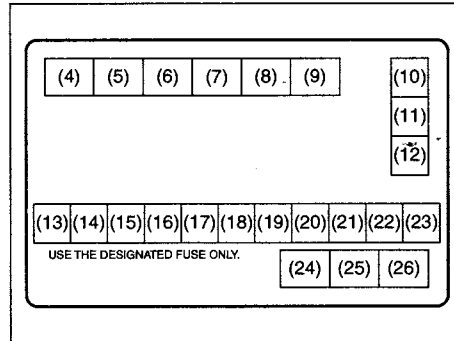

68KH077

MAIN FUSE/PRIMARY FUSE		
(1)	80A	All electric load
(2)	50A	Dome, Tail light, Rear defogger, Door lock
(3)	50A	Power window, Heater, Wiper, Ignition
(4)	-	Front fog light relay
(5)	-	Starting motor relay
(6)	-	Blank
(7)	-	Automatic transaxle relay
(8)	-	Air compressor relay
(9)	-	Blank
(10)	30A	ABS control module fuse 2
(11)	40A	Power steering fuse
(12)	40A	ABS control module fuse 1
(13)	30A	Ignition switch fuse
(14)	10A	Air compressor fuse
(15)	-	Blank
(16)	20A	Front fog light fuse
(17)	30A	Radiator fan fuse
(18)	15A	Automatic transaxle fuse
(19)	15A	Headlight (Left) fuse
(20)	15A	Headlight (Right) fuse
(21)	-	Blank
(22)	30A	Starting motor fuse

INSPECTION AND MAINTENANCE

(23)	15A	Fuel injection fuse
(24)	–	Radiator fan relay
(25)	–	Fuel pump relay
(26)	–	Main relay
(27)	80A	Head light, Air compressor, Front fog light, Radiator fan
(28)	80A	Power steering, ABS

The main fuse, primary fuses and some of the individual fuses are located in the engine compartment. If the main fuse blows, no electrical component will function. If a primary fuse blows, no electrical component in the corresponding load group will function. When replacing the main fuse, a primary fuse or an individual fuse, use a genuine SUZUKI replacement. To remove a fuse, use the fuse puller provided in the fuse box. The amperage of each fuse is shown in the back of the fuse box cover.

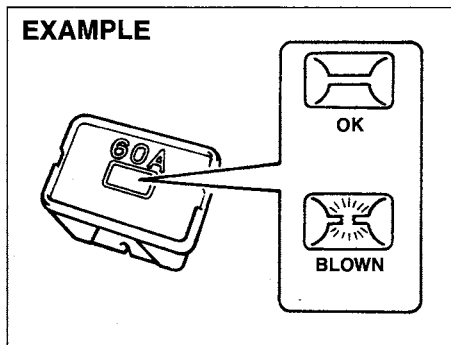

60G111

⚠ WARNING

If the main fuse or a primary fuse blows, be sure to have your vehicle inspected by an authorized SUZUKI dealer. Always use a genuine SUZUKI replacement. Never use a substitute such as a wire even for a temporary repair, or extensive electrical damage and a fire can result.

NOTE:

Make sure that the fuse box always carries spare fuses and fuse puller.

Fuses under the Dash Board

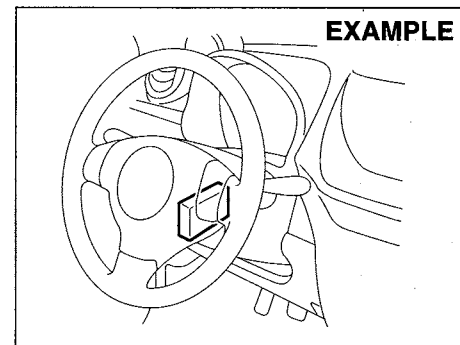

68KM076

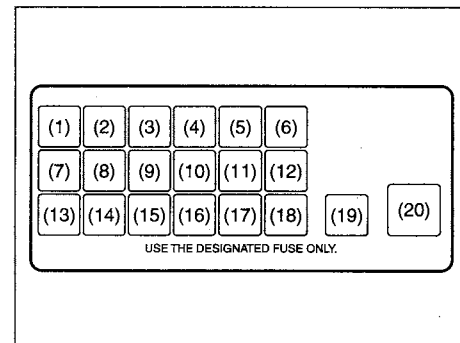

68KH079

MAIN FUSE/PRIMARY FUSE		
(1)	10A	Stop light
(2)	30A	Blower motor
(3)	10A	ST SIG
(4)	15A	Accessory
(5)	10A	Rear fog light
(6)	10A	Tail light
(7)	10A	Buck-up light
(8)	10A	ABS/ESP®
(9)	10A	Meter
(10)	15A	Ignition coil
(11)	20A	Wiper/Washer
(12)	10A	Heater
(13)	10A	IG1 SIG
(14)	10A	Air bag
(15)	–	Blank
(16)	20A	Door lock
(17)	15A	Horn/Hazard
(18)	20A	Rear defogger
(19)	10A	Dome
(20)	30A	Power window

The fuse box is located under the driver's side of the dashboard.

Remove the fuse box cover by pushing in at both ends and pulling off the cover.

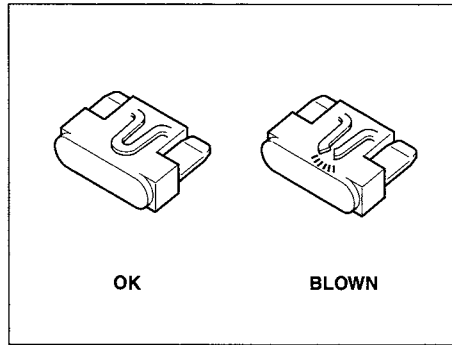

⚠ WARNING

Always be sure to replace a blown fuse with a fuse of the correct amperage. Never use a substitute such as aluminum foil or wire to replace a blown fuse. If you replace a fuse and the new one blows in a short period of time, you may have a major electrical problem. Have your vehicle inspected immediately by your SUZUKI dealer.

Bulb Replacement

⚠ WARNING

- Light bulbs can be hot enough to burn your finger right after being turned off. This is true especially for halogen headlight bulbs. Replace the bulbs after they become cool enough.
- The headlight bulbs are filled with pressurized halogen gas. They can burst and injure you if they are hit or dropped. Handle them carefully.

CAUTION

The oils from your skin may cause a halogen bulb to overheat and burst when the lights are on. Grasp a new bulb with a clean cloth.

CAUTION

Frequent replacement of a bulb indicates the need for an inspection of the electrical system. This should be carried out by your SUZUKI dealer.

INSPECTION AND MAINTENANCE

Interior Light

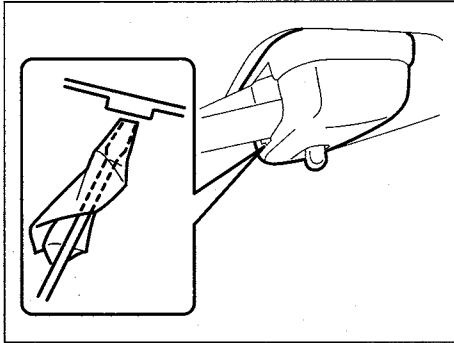

68KH080

Pull down the lens by using a flat blade screwdriver covered with a soft cloth as shown. To install it, simply push it back in.

The bulb can be removed by simply pulling it out. When replacing the bulb, make sure that the contact springs are holding the bulb securely.

Headlight

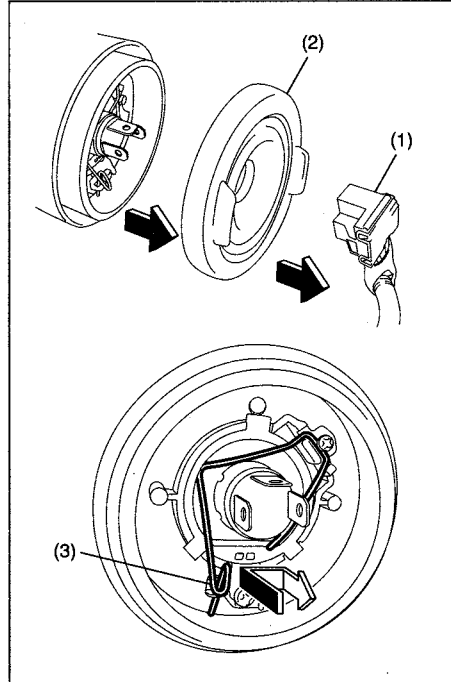

68KH081

Disconnect the coupler (1). Remove the sealing rubber (2).

Push the retaining spring (3) forward and unhook it. Then remove the bulb. Install a new bulb in the reverse order of terminal.

Front Fog Light (if equipped)

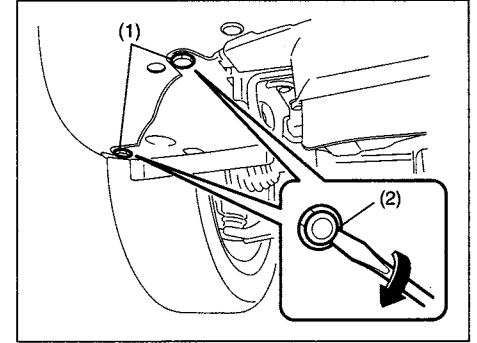

68KH082

1) Insert a flat blade screwdriver into the hole (2) and remove the clips (1) by twist the driver as shown in the illustration.

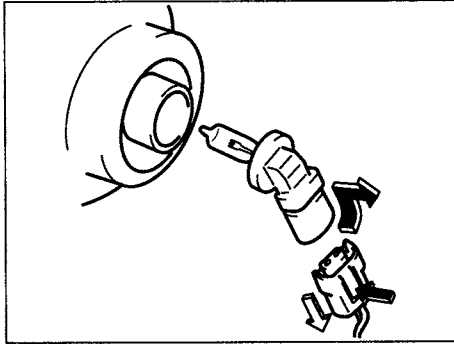

78F072

- 2) Open the fender cover. Disconnect the coupler with pushing the lock release. Turn the bulb holder counterclockwise and remove it.

Side Turn Signal Light

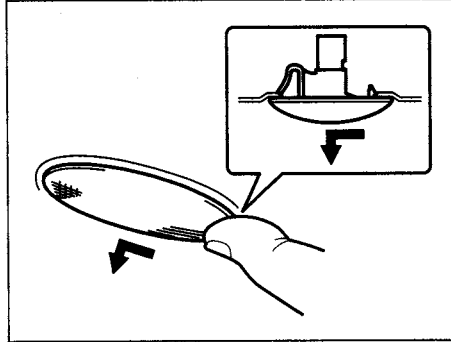

64J195

As the bulb is built-in type, the light assembly must be replaced. Remove the light assembly by sliding the light housing forward with your finger.

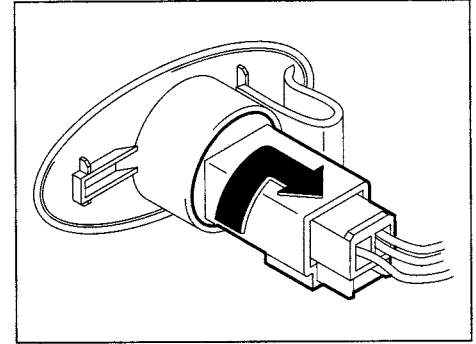

68KH103

To remove a bulb holder from a light housing, turn the holder clockwise and pull it out. Then remove the bulb. Install a new bulb in the reverse order.

INSPECTION AND MAINTENANCE

Other General Lights

Bulb holder

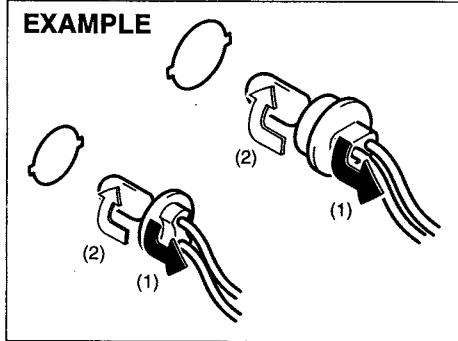

- (1) Removal
- (2) Installation

To remove a bulb holder from a light housing, turn the holder counterclockwise and pull it out. To install the holder, push the holder in and turn it clockwise.

Bulb

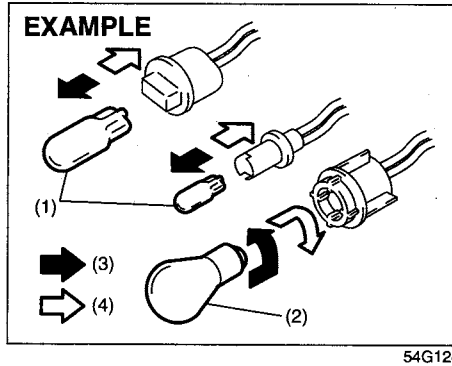

- (3) Removal
- (4) Installation

There are two types of bulb, "Full glass type" (1) and "Glass/metal type" (2).

To remove and install a full glass type bulb (1), simply pull out or push in the bulb.

To remove a glass metal type bulb (2) from a bulb holder, push in the bulb and turn it counterclockwise. To install a new bulb, push it in and turn it clockwise.

You can access the individual bulb or bulb holders as follows.

Front position light (1) Front turn signal light (2)

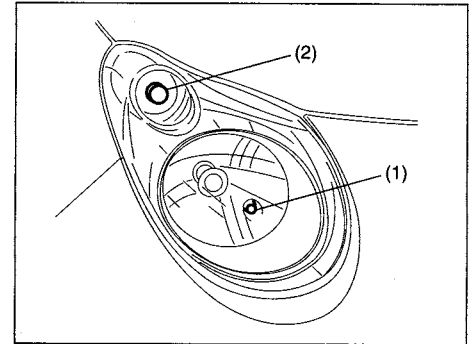

Rear combination light

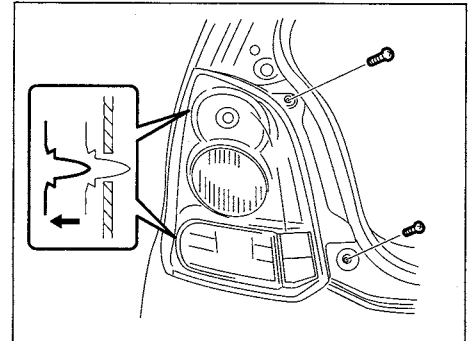

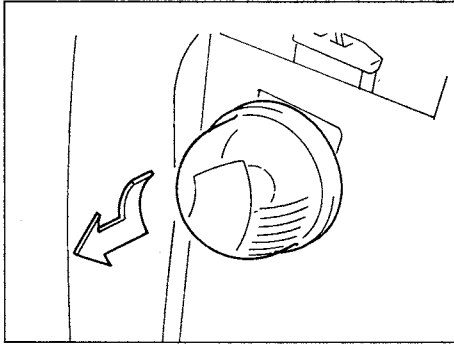
License plate light

75F087

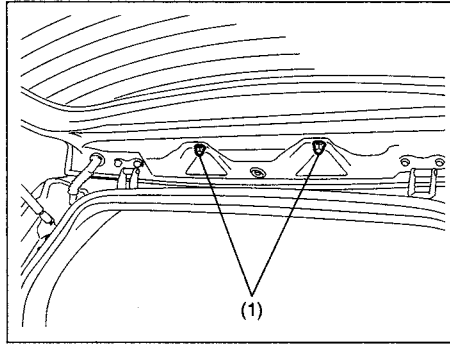
High-mount stop light (if equipped)

68KH085

To remove a high-mounted stop light housing the following procedure:

- 1) Open the tailgate, and remove the nuts (1) as shown in the illustration.

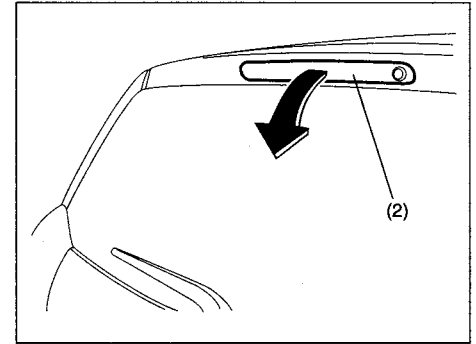

68KH086

- 2) Close the tailgate. Remove a high-mounted stop light housing (2) from the tailgate.

Wiper Blades

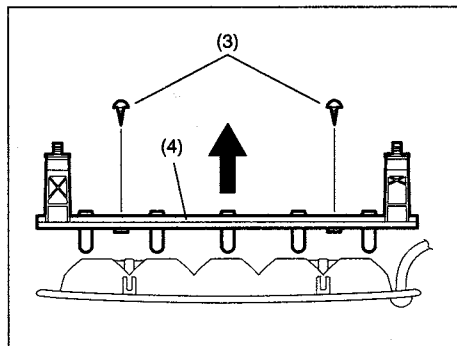

68KH087

- 3) Remove the bolts (3) and remove the bulb holder (4).
- 4) Replace the bulbs.
To install a high-mounted stop light housing in the reverse order of removal.

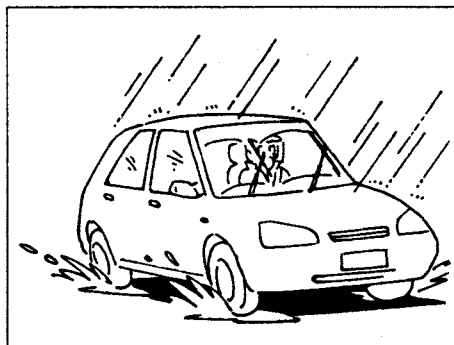

54G129

If the wiper blades become brittle or damaged, or make streaks when wiping, replace the wiper blades.

To install new wiper blades, follow the procedures below.

CAUTION

To avoid scratching or breaking the window, do not let the wiper arm strike the window while replacing the wiper blade.

NOTE:

Some wiper blades may be different from the ones described here depending on vehicle specifications. If so, consult your SUZUKI dealer for proper replacement method.

For windshield wipers:

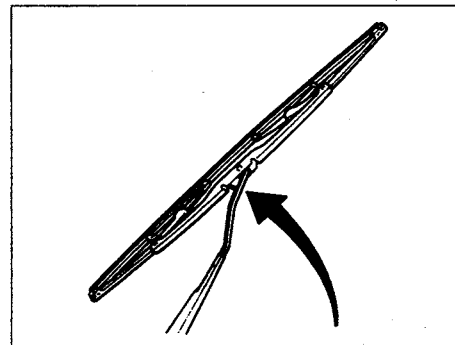

70G119

- 1) Hold the wiper arm away from the window.

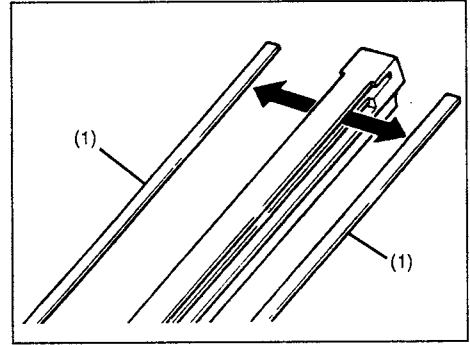
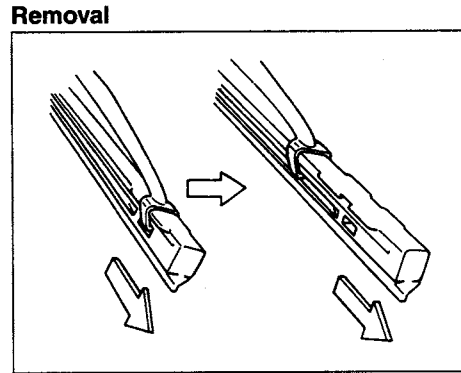
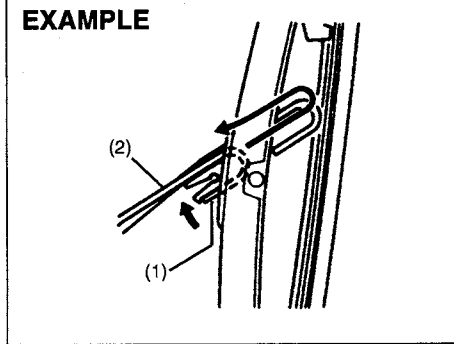
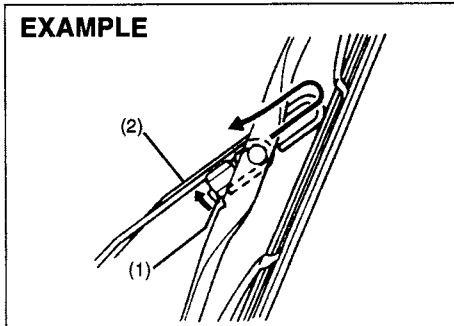

60A260

54G135

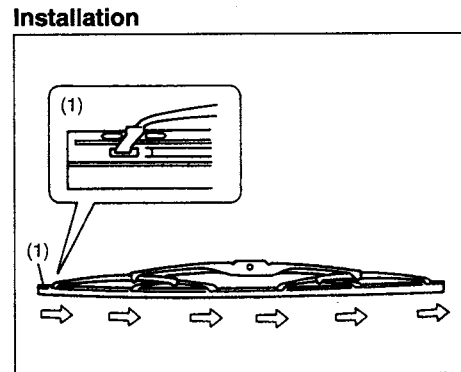

54G132

(1) Retainer

- 4) If the new blade is provided without the two metal retainers, move them from the old blade to the new one.
- 5) Install the new blade in the reverse order of removal, with the locked end positioned toward the wiper arm. Make sure the blade is properly retained by all the hooks. Lock the blade end into place.
- 6) Reinstall wiper frame to arm, making sure that the lock lever is snapped securely into the arm.

- 2) Squeeze lock (1) towards wiper arm (2) and remove the wiper frame from the arm as shown.
- 3) Unlock the lock end of the wiper blade and slide the blade out as shown.

(1) Locked end

INSPECTION AND MAINTENANCE

For rear wipers:

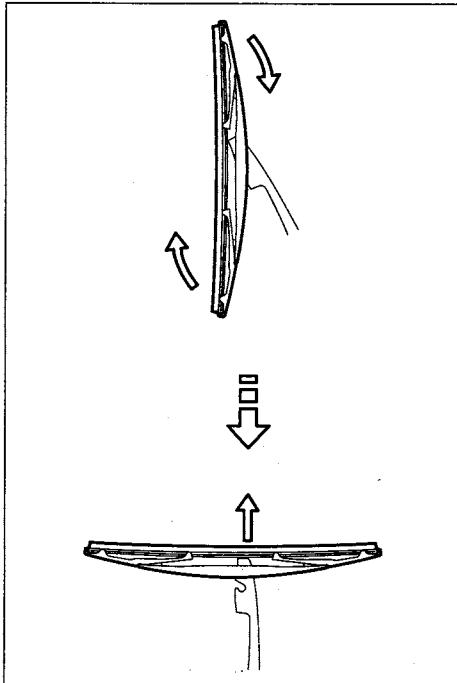

- 1) Hold the wiper arm away from the window.
- 2) Remove the wiper frame from the arm as shown.
- 3) Slide the blade out as shown.

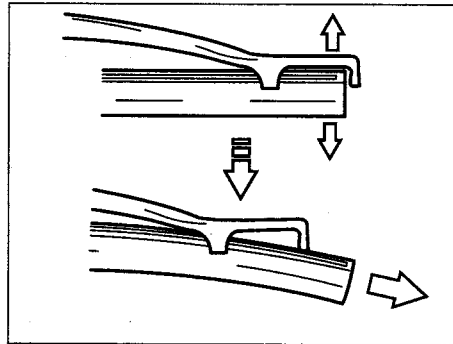

NOTE:

Do not flex the wiper blade frame end more than necessary. If you do, it can break off.

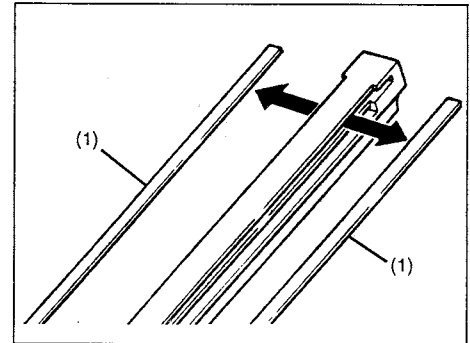

(1) Retainer

- 4) If the new blade is provided without the two metal retainers, move them from the old blade to the new one.
- 5) Install the new blade in the reverse order of removal.
Make sure the blade is properly retained by all the hooks.
- 6) Reinstall wiper frame to arm in the reverse order of removal.

Windshield Washer Fluid

Front and rear

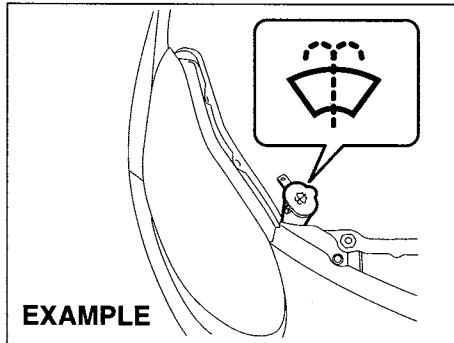

68KH088

Check that there is washer fluid in the tank. Refill it if necessary. Use a good quality windshield washer fluid, diluted with water as necessary.

⚠ WARNING

Do not use "antifreeze" solution in the windshield washer reservoir. This can severely impair visibility when sprayed on the windshield, and can also damage your vehicle's paint.

CAUTION

Damage may result if the washer motor is operated with no fluid in the washer tank.

Air Conditioning System

If you do not use the air conditioner for a long period, such as during winter, it may not give the best performance when you start using it again. To help maintain optimum performance and durability of your air conditioner, it needs to be run periodically. Operate the air conditioner at least once a month for one minute with the engine idling. This circulates the refrigerant and oil and helps protect the internal components.

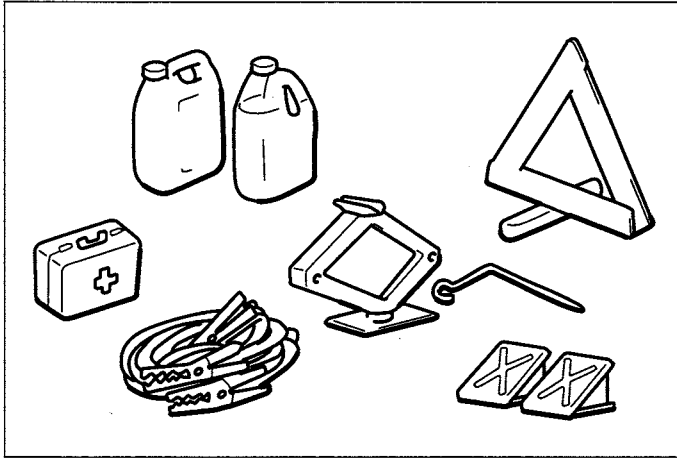
EMERGENCY SERVICE

60G411

Tire Changing Tool	8-1
Jacking Instructions	8-3
Changing Wheels	8-4
Flat Tire Repair Kit (if equipped)	8-5
Jump Starting Instructions	8-9
Towing	8-11
If the Starter Does Not Operate	8-11
If the Engine is Flooded	8-12
If the Engine Overheats	8-12

EMERGENCY SERVICE

Tire Changing Tool

Type A

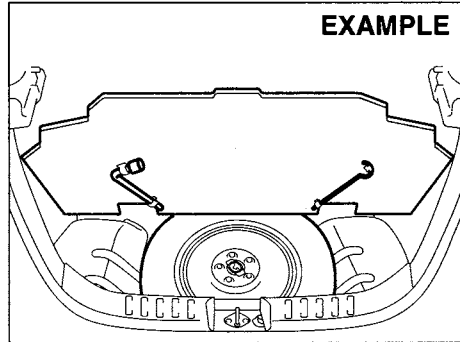

68KM094

Type B

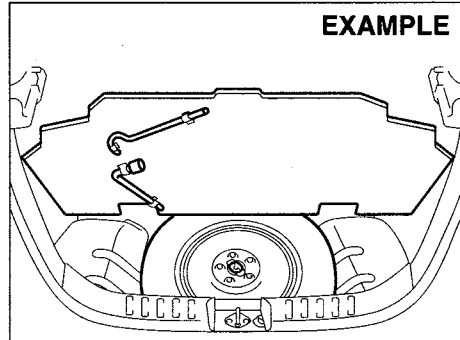

68KN031

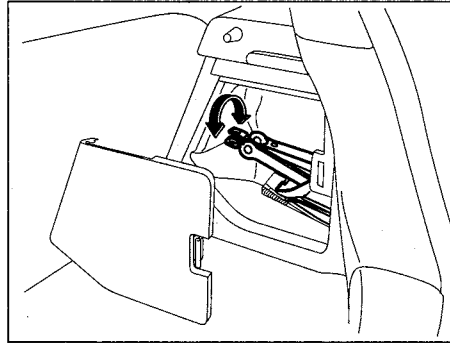

68KH090

The wheel brace and jack handle are stowed in back of the luggage board. The jack is stowed in the side of the luggage compartment. Remove the cover to access the jack.

Type A

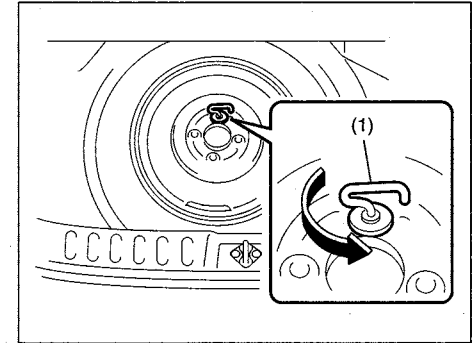

68KH091

Type B

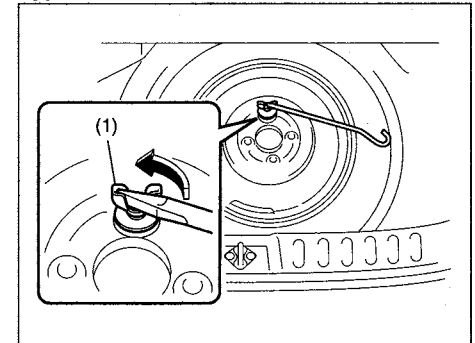

68KM091

To remove the spare tire, turn its bolt (1) counterclockwise and remove it.

NOTE:

For type B, if the bolt is too tight to turn, use the jack handle to loose it as shown in the above illustration. Do not use the jack handle to tighten it.

To remove the jack, turn its shaft counter-clockwise and pull the jack out of the storage bracket. To stow the jack, place it in the storage bracket and turn the shaft clockwise until the jack is securely held in place.

⚠ WARNING

The jack should be used only to change wheels. It is important to read the jacking instructions in this section before attempting to use the jack.

⚠ WARNING

After using the tire changing tools, be sure to stow them securely or they can cause injury if an accident occurs.

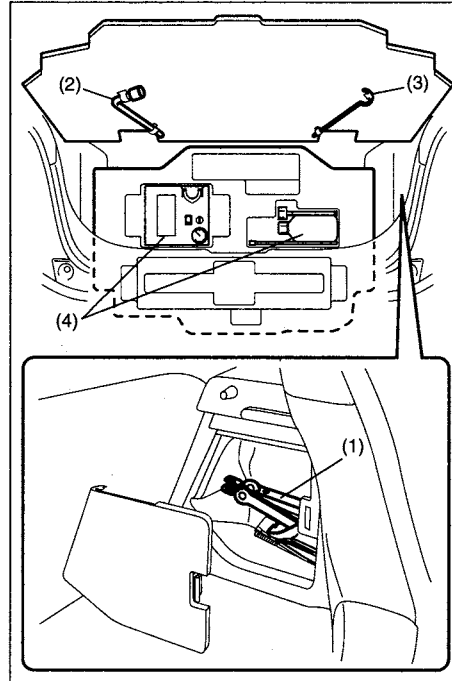
Flat Tire Repair Kit and Tire Changing Tool (if equipped)

68KM095

- (1) Jack
- (2) Wheel brace
- (3) Jack handle

- (4) Flat tire repair kit
- (5) Storage case

The jack is stowed in the side of luggage compartment, the tire changing tools are stowed in back of the luggage board and the flat tire repair kit are stowed under the load floor in the luggage compartment. For details of the flat tire repair kit, refer to "Flat tire repair kit" in this section.

⚠ WARNING

The jack should be used only to change wheels. It is important to read the jacking instructions in this section before attempting to use the jack.

⚠ WARNING

After using the tire changing tools or the flat tire repair kit, be sure to stow them in the case (5) securely or they can cause injury if an accident occurs.

Jacking Instructions

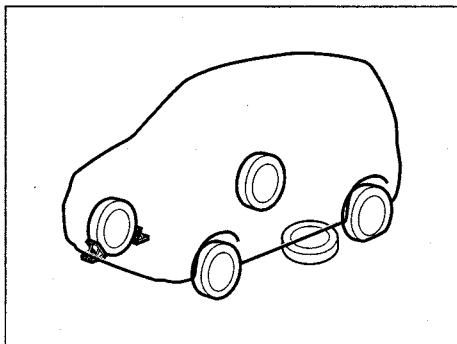

52KM119

- 1) Place the vehicle on level, hard ground.
- 2) Set the parking brake firmly and shift into "P" (Park) if your vehicle has an automatic transaxle, or shift into "R" (Reverse) if your vehicle has a manual transaxle.
- 3) Turn on the hazard warning flasher if your vehicle is near traffic.
- 4) Block the front and rear of the wheel diagonally opposite of the wheel being lifted.
- 5) Place the spare wheel near the wheel being lifted as shown in the illustration in case that the jack slips.

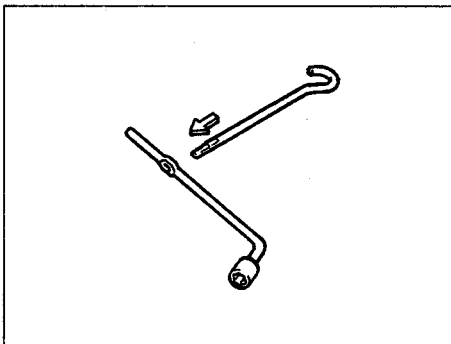

54G253

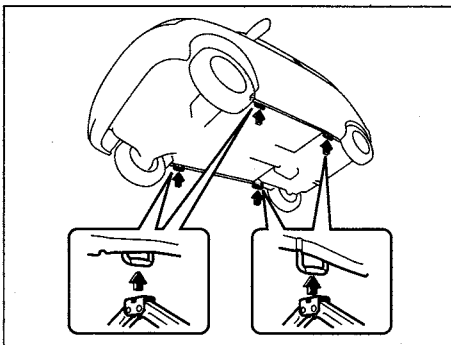

63J100

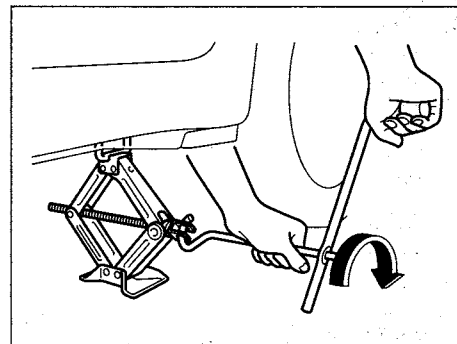

63J101

- 6) Position the jack vertically and raise the jack by turning the jack handle clockwise until the jack head groove fits around the jacking bar beneath the vehicle body. See illustrations.
- 7) Continue to raise the jack slowly and smoothly until the tire clears the ground. Do not raise the vehicle more than necessary.

⚠ WARNING

- Use the jack only to change wheels on level, hard ground.
- Never jack up the vehicle on an inclined surface.
- Never raise the vehicle with the jack in a location other than the specified jacking point (shown in the illustration) near the wheel to be changed.
- Make sure that the jack is raised at least 51 mm (2 inches) before it contacts the suspension arm boss. Use of the jack when it is within 51 mm (2 inches) of being fully collapsed may result in failure of the jack.
- Never get under the vehicle when it is supported by the jack.
- Never run the engine when the vehicle is supported by the jack and never allow passengers to remain in the vehicle.

Changing Wheels

To change a wheel, use the following procedure:

- 1) Clear all passengers and luggage from the vehicle.

NOTE:

The jack is located in the side of luggage compartment, and the tools are located in back of the luggage board.

- 2) Remove the jack, tools and spare wheel from the vehicle.
- 3) Loosen, but do not remove the wheel nuts.
- 4) Jack up the vehicle.
- 5) Remove the wheel nuts and wheel.
- 6) Before installing the new wheel, clean any mud or dirt off from the surface of the wheel and hub with a clean cloth. Clean the hub carefully; it may be hot from driving.
- 7) Install the new wheel and replace the wheel nuts with their cone shaped end facing the wheel. Tighten each nut snugly by hand until the wheel is securely seated on the hub.

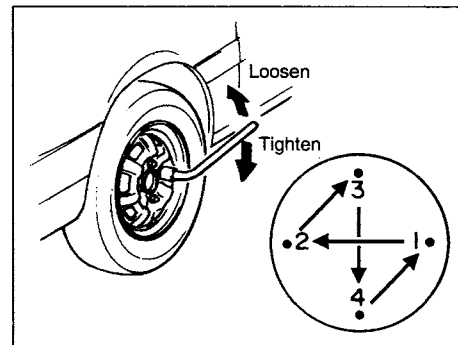

54G116

**Tightening torque for wheel nut
85 Nm (8.5 kg-m, 61.5 lb-ft)**

- 8) Lower the jack and fully tighten the nuts in a crisscross fashion with a wrench as shown in the illustration.

⚠ WARNING

Use genuine wheel nuts and tighten them to the specified torque as soon as possible after changing wheels. Incorrect wheel nuts or improperly tightened wheel nuts may come loose or fall off, which can result in an accident. If you do not have a torque wrench, have the wheel nut torque checked by an authorized SUZUKI dealer.

Flat Tire Repair Kit (if equipped)

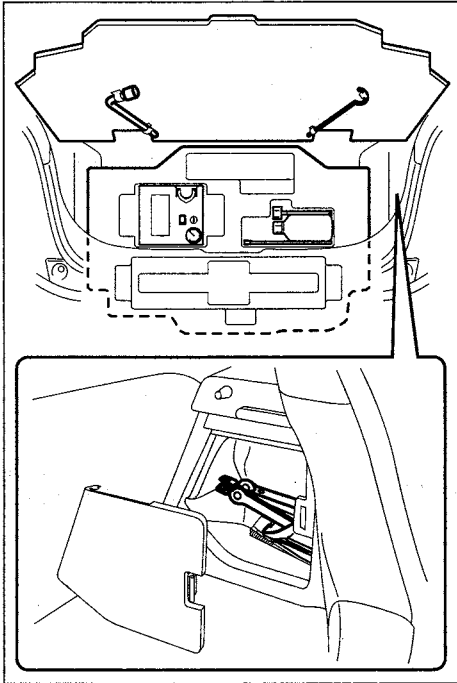

68KM096

The jack is stowed in the side of luggage compartment, the tire changing tools are stowed in back of the luggage board and the flat tire repair kit are stowed under the load floor in the luggage compartment.

Take a moment to read the attached explanatory leaflet before using the flat tire repair kit.

CAUTION

The flat tire repair kit cannot be used in the following cases. Consult a SUZUKI dealer or a roadside assistance service.

- Cuts or piercing in the tire tread larger than approx. 4 mm.
- Cuts in the tire side wall.
- Tire damage caused by driving with considerably reduced tire pressure or even with deflated tire.
- The tire bead completely unseated outside of the rim.
- The rim damaged.

Small punctures in the tire tread, caused by a nail or a screw, can be sealed with the flat tire repair kit. Do not remove nails or screws from the tire during an emergency repair.

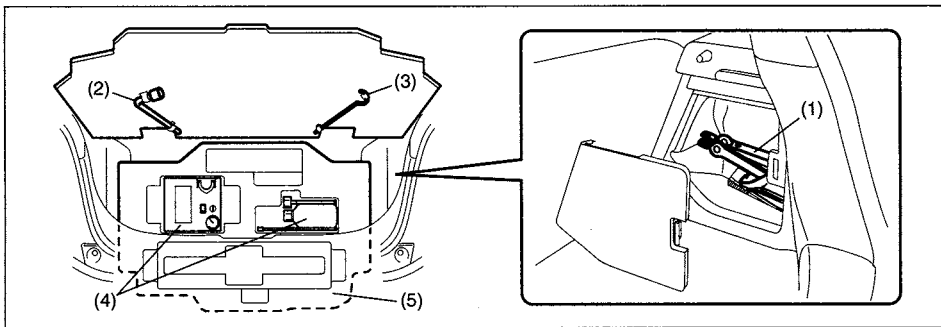

- (1) Jack
 (2) Wheel brace
 (3) Jack handle
 (4) Flat tire repair kit
 (5) Storage case

68KM097

⚠ WARNING

The flat tire repair kit sealant is harmful if swallowed, or it comes in contact with skin or eyes. If swallowed, do not induce vomiting. Give plenty of water (if possible charcoal slurry) and seek medical attention immediately. If sealant gets in eyes, flush eyes with water and seek medical attention. Solution can be poisonous to animals. Keep out of the reach of children and animals.

Flat tire repair kit contents (4)

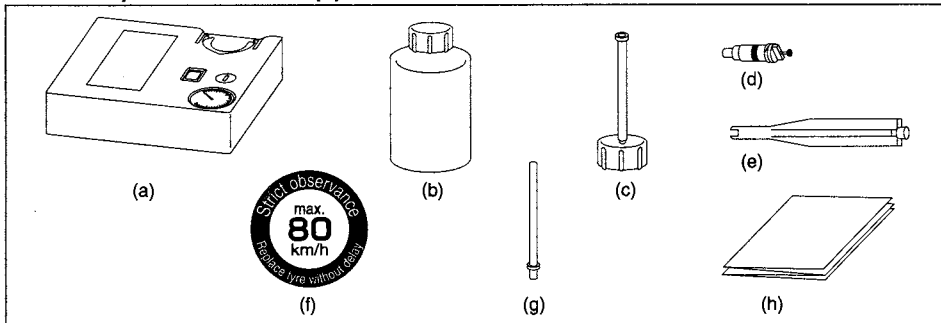

- (a) Air compressor
 (b) Sealant bottle
 (c) Filler hose
 (d) Valve insert (spare)
 (e) Valve insert remover
 (f) Speed restriction sticker
 (g) Extension hose (for draining sealant)
 (h) Explanatory leaflet

51KM054

EMERGENCY SERVICE

CAUTION

Be sure to replace the sealant before expiry date indicated on the label of the sealant bottle. To purchase new sealant, see your SUZUKI dealer.

How to Perform an Emergency Repair

- 1) Place the vehicle on level, hard ground. Set the parking brake firmly and shift into "P" (Park) if your vehicle has an automatic transaxle or shift into "R" (Reverse) if your vehicle has a manual transaxle. Turn on the hazard warning flasher if your vehicle is near traffic. Block the front and rear of the wheel diagonally opposite of the wheel being repaired.
- 2) Take out the sealant bottle and the compressor, and shake the bottle well.

NOTE:

Shake the bottle well before screwing the filler hose onto the bottle.

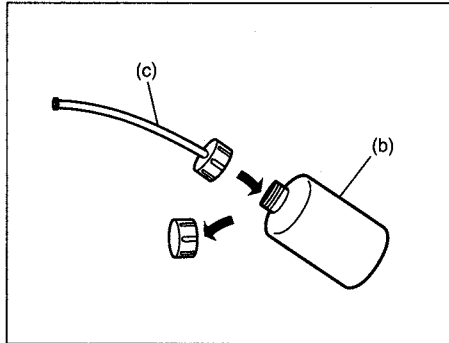

51KM055

- 3) Remove the cap of the bottle (b), and screw the enclosed filler hose (c), onto the bottle, thereby piercing the inner cap of the bottle.

NOTE:

Screw the filler hose without removing the inner cap of the bottle.

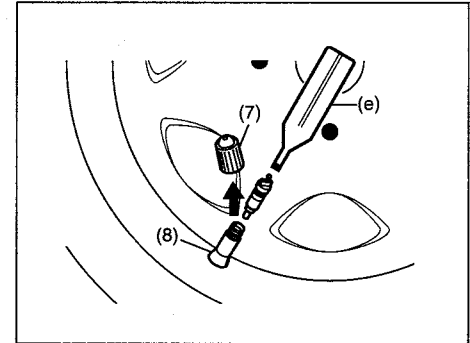

51KM056

- 4) Unscrew the valve cap (7) from the tire valve (8). Unscrew the valve insert by using the enclosed valve insert remover (e).

WARNING

The valve insert can jump out, if air remains in the tire. Be careful when removing the valve insert.

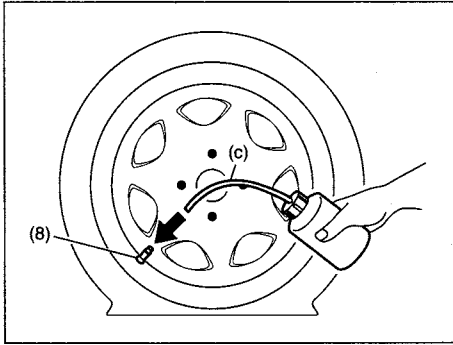

51KM057

- 5) Remove the plug from the filler hose (c) and insert the filler hose into the tire valve.

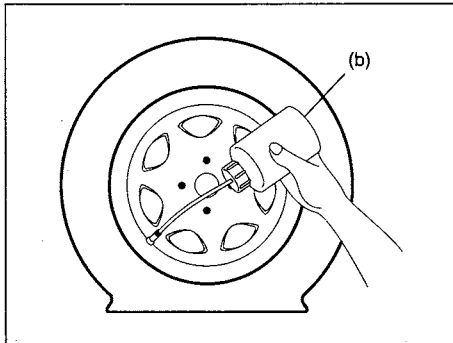

51KM057

- 6) Hold the bottle (b) with bottom upwards and pump the bottle to fill the entire bot-

tle contents (sealant) into the tire. Thereafter pull off the filler hose and firmly screw the valve insert into the tire valve again. If the valve insert is dirty or lost, use the enclosed spare valve insert.

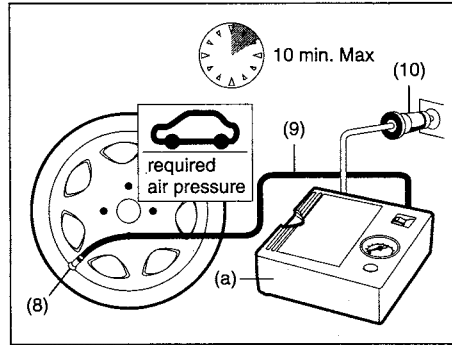

51KM059

- 7) Screw the air hose (9) of the compressor (a) to the tire valve (8). Fit the power plug (10) to the cigar lighter socket. Set the key to "ACC" or "ON" position. Switch on the compressor. Inflate the tire to the required air pressure.

⚠ WARNING

Do not stand by the tire, when inflating. It can burst.

CAUTION

Do not operate the compressor for longer than 10 minutes with out cease. It can cause overheating the of compressor.

If the air pressure still cannot be reached, the required air pressure, the tire may be severely damaged. In this case, the flat tire repair kit cannot provide the necessary seal. Consult a SUZUKI dealer or a roadside assistance service.

NOTE:

If over inflated, deflate air by pressing the button.

- 8) Make a short drive immediately after inflating to the required air pressure. Drive carefully with a maximum speed of 80 km/h.

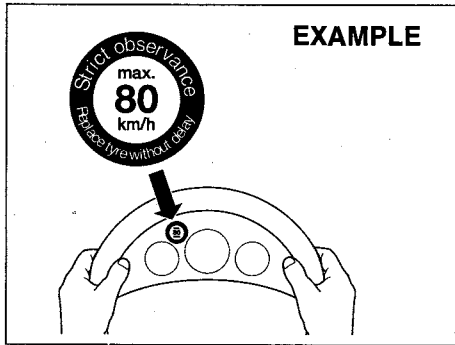

- 9) Affix the enclosed speed restriction label in the driver's field of view, and carry on driving carefully to the nearest SUZUKI dealer or a tire repair shop.

⚠ WARNING

Do not affix the speed restriction label to the air bag cover. Also do not affix it to the warning light indicator or to the speedometer.

- 10) After 10 minutes or 5 km (3 mile) running, check the tire pressure with the pressure gauge of the compressor. If the air pressure is indicated more than 130 kPa (1.3 bar), the emergency repair is completed. But, if the air pressure is indicated less than the required air pressure, correct the tire pressure to the required air pressure. If the tire

pressure has dropped below 130 kPa (1.3 bar), the flat tire repair kit cannot provide the necessary seal. Do not drive on and consult a SUZUKI dealer or a roadside assistance service.

⚠ WARNING

Be sure to check the tire pressure and to confirm the completion of the emergency repair.

CAUTION

Have the tire renewed at the nearest SUZUKI dealer. When repair to reuse the sealed tire, consult a tire repair shop.

The wheel can be reused after wiping sealant off completely with cloth in order not to rust, but the tire valve must be renewed.

Hand the used bottle, filler hose, and extension hose over to a SUZUKI dealer since these are needed to extract sealant from the tire.

Jump Starting Instructions

⚠ WARNING

- Never attempt to jump start your vehicle if the battery appears to be frozen. Batteries in this condition may explode or rupture if jump starting is attempted.
- When making jump lead connections, be certain that your hands and the jump leads remain clear from pulleys, belts, or fans.
- Batteries produce flammable hydrogen gas. Keep flames and sparks away from the battery or an explosion may occur. Never smoke when working in the vicinity of the battery.
- If the booster battery you use for jump starting is installed in another vehicle, make sure the two vehicles are not touching each other.
- If your battery discharges repeatedly, for no apparent reason, have your vehicle inspected by an authorized SUZUKI dealer.
- To avoid harm to yourself or damage to your vehicle or battery, follow the jump starting instructions below precisely and in order. If you are in doubt, call for qualified road service.

CAUTION

Your vehicle should not be started by pushing or towing. This starting method could result in permanent damage to the catalytic converter. Use jump leads to start a vehicle with a weak or flat battery.

When Jump Starting Your Vehicle, Use the Following Procedure:

- 1) Use only a 12-volt battery to jump start your vehicle. Position the good 12-volt-battery close to your vehicle so that the jump leads will reach both batteries. When using a battery installed on another vehicle, **DO NOT LET THE VEHICLES TOUCH**. Set the parking brakes fully on both vehicles.
- 2) Turn off all vehicle accessories, except those necessary for safety reasons (for example, headlights or hazard lights).

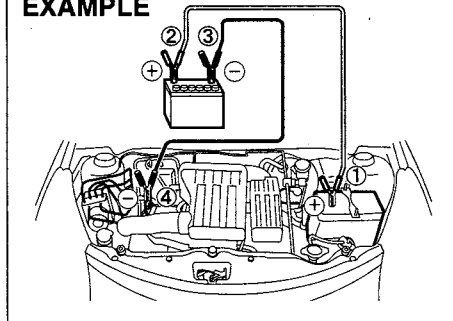
EXAMPLE

68KH092

- 3) Make jump lead connections as follows:
 1. Connect one end of the first jump lead to the positive (+) terminal of the flat battery (1).
 2. Connect the other end to the positive (+) terminal of the booster battery (2).
 3. Connect one end of the second jump lead to the negative (-) terminal of the booster battery (2).
 4. Make the final connection to an unpainted, heavy metal part (i.e. engine hook (3)) of the engine of the vehicle with the flat battery (1).

⚠ WARNING

Never connect the jump lead directly to the negative (-) terminal of the discharged battery, or an explosion may occur.

- 4) If the booster battery you are using is fitted to another vehicle, start the engine of the vehicle with the booster battery. Run the engine at moderate speed.
- 5) Start the engine of the vehicle with the flat battery.
- 6) Remove the jump leads in the exact reverse order in which you connected them.

Towing

If you need to have your vehicle towed, contact a professional service. Your dealer can provide you with detailed towing instructions.

CAUTION

To help avoid damage to your vehicle during towing, proper equipment and towing procedures must be used.

2-Wheel Drive (2WD) Automatic Transaxle

Automatic transaxle vehicles may be towed using either of the following methods.

- 1) From the front, with the front wheels lifted and the rear wheels on the ground. Before towing, make sure that the parking brake is released.
- 2) From the rear, with the rear wheels lifted and a dolly under the front wheels.

CAUTION

Towing your vehicle with the front wheels on the ground can result in damage to the automatic transaxle.

2-Wheel Drive (2WD) Manual Transaxle

Manual transaxle vehicles may be towed using either of the following methods.

- 1) From the front, with the front wheels lifted and the rear wheels on the ground. Before towing, make sure that the parking brake is released.
- 2) From the rear, with the rear wheels lifted and the front wheels on the ground, provided the steering and drivetrain are in operational condition. Before towing, make sure that transaxle is in neutral, the steering wheel is unlocked (the ignition key should be in the "ACC" position), and the steering wheel is secured with a clamping device designed for towing service.

CAUTION

The steering column is not strong enough to withstand shocks transmitted from the front wheels during towing. Always unlock the steering wheel before towing.
--

If the Starter Does Not Operate

- 1) Try turning the ignition switch to the "START" position with the headlights turned on to determine the battery condition. If the headlights go excessively dim or go off, it usually means that either the battery is flat or the battery terminal contact is poor. Recharge the battery or correct battery terminal contact as necessary.
- 2) If the headlights remain bright, check the fuses. If the reason for failure of the starter is not obvious, there may be a major electrical problem. Have the vehicle inspected by your authorized SUZUKI dealer.

If the Engine is Flooded

If the engine is flooded with gasoline, it may be hard to start. If this happens, press the accelerator pedal all the way to the floor and hold it there while cranking the engine. (Do not operate the starter motor for more than 15 seconds).

If the Engine Overheats

The engine could overheat temporarily under severe driving conditions. If the high engine coolant temperature warning light comes on as overheating during driving:

- 1) Turn off the air conditioner, if equipped.
- 2) Take the vehicle to a safe place and park.
- 3) Let the engine run at the normal idle speed for a few minutes until the high engine coolant temperature warning light goes off.

⚠ WARNING

If you see or hear escaping steam, stop the vehicle in a safe place and immediately turn off the engine to let it cool. Do not open the hood when steam is present. When the steam can no longer be seen or heard, open the hood to see if the coolant is still boiling. If it is, you must wait until it stops boiling before you proceed.

If the high engine coolant temperature warning light does not go off:

- 1) Turn off the engine and check that the water pump belt and pulleys are not damaged or slipping. If any abnormality is found, correct it.

- 2) Check the coolant level in the reservoir. If it is found to be lower than the "LOW" line, look for leaks at the radiator, water pump, and radiator and heater hoses. If you locate any leaks that may have caused the overheating, do not run the engine until these problems have been corrected.
- 3) If you do not find a leak, carefully add coolant to the reservoir and then the radiator, if necessary. (Refer to "Engine Coolant" in the "INSPECTION AND MAINTENANCE" section.)

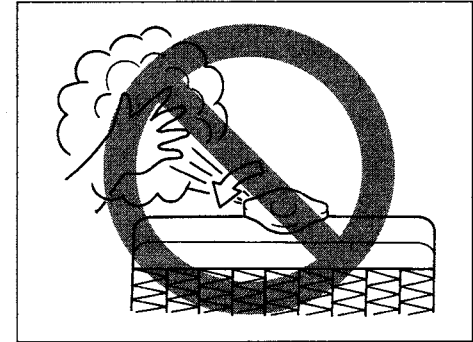

65D614

WARNING

- It is hazardous to remove the radiator cap (or degassing tank cap for Diesel engine) when the water temperature is high, because scalding fluid and steam may be blown out under pressure. The cap should only be taken off when the coolant temperature has lowered.
- To help prevent personal injury, keep hands, tools and clothing away from the engine cooling fan and air-conditioner fan (if equipped). These electric fans can automatically turn on without warning.

APPEARANCE CARE

Corrosion Prevention 9-1
Vehicle Cleaning 9-2

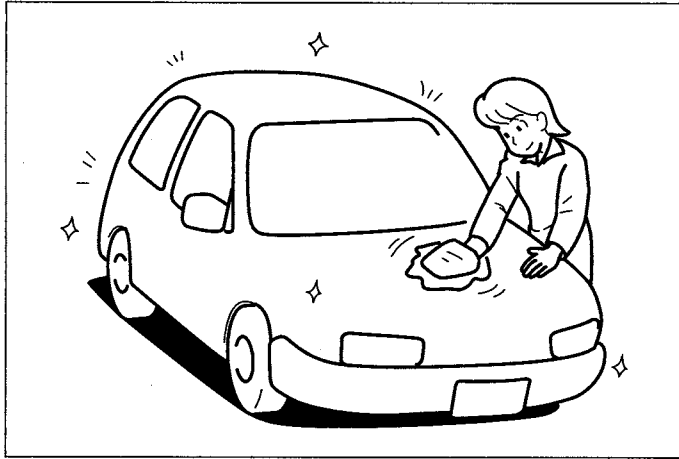

60G412

Corrosion Prevention

It is important to take good care of your vehicle to protect it from corrosion. Listed below are instructions for how to maintain your vehicle to prevent corrosion. Please read and follow these instructions carefully.

Important Information About Corrosion

Common causes of corrosion

- 1) Accumulation of road salt, dirt, moisture, or chemicals in hard-to-reach areas of the vehicle underbody or frame.
- 2) Chipping, scratches and any damage to treated or painted metal surfaces resulting from minor accidents or abrasion by stones and gravel.

Environmental conditions which accelerate corrosion

- 1) Road salt, dust control chemicals, sea air or industrial pollution will all accelerate the corrosion of metal.
- 2) High humidity will increase the rate of corrosion particularly when the temperature range is just above the freezing point.
- 3) Moisture in certain areas of a vehicle for an extended period of time may promote corrosion even though other body sections may be completely dry.
- 4) High temperatures will cause an accelerated rate of corrosion to parts of the

vehicle which are not well ventilated to permit quick drying.

This information illustrates the necessity of keeping your vehicle (particularly the underbody) as clean and dry as possible. It is equally important to repair any damage to the paint or protective coatings as soon as possible.

How to Help Prevent Corrosion

Wash your vehicle frequently

The best way to preserve the finish on your vehicle and to help avoid corrosion is to keep it clean with frequent washing.

Wash your vehicle at least once during the winter and once immediately after the winter. Keep your vehicle, particularly the underside, as clean and dry as possible.

If you frequently drive on salted roads, your vehicle should be washed at least once a month during the winter. If you live near the ocean, your vehicle should be washed at least once a month throughout the year.

For washing instructions, refer to the "Vehicle Cleaning" section.

Remove foreign material deposits

Foreign material such as salts, chemicals, road oil or tar, tree sap, bird droppings and industrial fall-out may damage the finish of your vehicle if it is left on painted surfaces. Remove these types of deposits as quickly as possible. If these deposits are difficult to wash off, an additional cleaner may be

required. Be sure that any cleaner you use is not harmful to painted surfaces and is specifically intended for your purposes. Follow the manufacturer's directions when using these special cleaners.

Repair finish damage

Carefully examine your vehicle for damage to the painted surfaces. Should you find any chips or scratches in the paint, touch them up immediately to prevent corrosion from starting. If the chips or scratches have gone through to the bare metal, have a qualified body shop make the repair.

Keep passenger and luggage compartments clean

Moisture, dirt or mud can accumulate under the floor mats and may cause corrosion. Occasionally, check under these mats to ensure that this area is clean and dry. More frequent checks are necessary if the vehicle is used off road or in wet weather.

Certain cargos such as chemicals, fertilizers, cleaners, salts, etc. are extremely corrosive by nature. These products should be transported in sealed containers. If a spill or leak does occur, clean and dry the area immediately.

Store your vehicle in a dry, well-ventilated area

Do not park your vehicle in a damp, poorly ventilated area. If you often wash your vehicle in the garage or if you frequently drive it in when wet, your garage may be damp. The high humidity in the garage may cause or accelerate corrosion. A wet vehicle may corrode even in a heated garage if the ventilation is poor.

⚠ WARNING

Do not apply additional undercoating or rust preventive coating on or around exhaust system components such as the catalytic converter, exhaust pipes, etc. A fire could be started if the undercoating substance becomes overheated.

Vehicle Cleaning

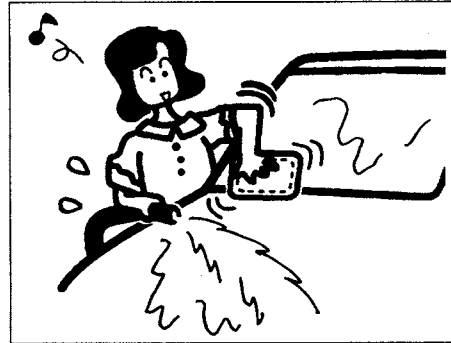

76G044S

⚠ WARNING

When cleaning the interior or exterior of the vehicle, NEVER USE flammable solvents such as lacquer thinners, gasoline, benzene or cleaning materials such as bleaches or strong household detergents. The materials could cause personal injury or damage to the vehicle.

Cleaning the Interior

Vinyl upholstery

Prepare a solution of soap or mild detergent mixed with warm water. Apply the solution to the vinyl with a sponge or soft cloth and let it soak for a few minutes to loosen dirt.

Rub the surface with a clean, damp cloth to remove dirt and the soap solution. If some dirt still remains on the surface, repeat this procedure.

Fabric upholstery

Remove loose dirt with a vacuum cleaner. Using a mild soap solution, rub stained areas with a clean damp cloth. To remove soap, rub the areas again with a cloth dampened with water. Repeat this until the stain is removed, or use a commercial fabric cleaner for tougher stains. If you use a fabric cleaner, carefully follow the manufacturer's instructions and precautions.

Seat belts

Clean seat belts with a mild soap and water. Do not use bleach or dye on the belts. They may weaken the fabric in the belts.

Vinyl floor mats

Ordinary dirt can be removed from vinyl with water or mild soap. Use a brush to help loosen dirt. After the dirt is loosened, rinse the mat thoroughly with water and dry it in the shade.

APPEARANCE CARE

Carpets

Remove dirt and soil as much as possible with a vacuum cleaner. Using a mild soap solution, rub stained areas with a clean damp cloth. To remove soap, rub the areas again with a cloth dampened with water. Repeat this until the stain is removed, or use a commercial carpet cleaner for tougher stains. If you use a carpet cleaner, carefully follow the manufacturer's instructions and precautions.

Cleaning the Exterior

CAUTION

It is important that your vehicle be kept clean and free from dirt. Failure to keep your vehicle clean may result in fading of the paint or corrosion to various parts of the vehicle body.

Washing

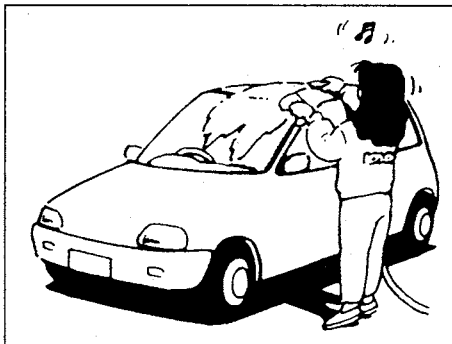

60B212S

⚠ WARNING

- Never attempt to wash and wax your vehicle with the engine running.
- When cleaning the underside of the body and fender, where there may be sharp-edged parts, you should wear gloves and a long-sleeved shirt to protect your hands and arms from being cut.
- After washing your vehicle, carefully test the brakes before driving to make sure they have maintained their normal effectiveness.

When washing the vehicle, park it where direct sunlight does not fall on it and follow the instructions below:

- 1) Flush the underside of body and wheel housings with pressurized water to remove mud and debris. Use plenty of water.

CAUTION

- When washing the vehicle: Avoid directing steam or hot water of more than 80°C (176°F) on plastic parts.
- To avoid damaging engine components, do not use pressurized water in the engine compartment.
- Do not pour the water on the battery, And wipe off the water which remains on the battery. The water entering inside the battery possibly causes fluid leakage.

- 2) Rinse the body to loosen the dirt. Remove dirt and mud from the body exterior with running water. You may use a soft sponge or brush. Do not use hard materials which can scratch the paint or plastic. Remember that the headlight covers or lenses are made of plastic in many cases.

CAUTION

To avoid damage to the paint or plastic surface, do not wipe the dirt off without ample water. Be sure to follow above procedure.

- 3) Wash the entire exterior with a mild detergent or car wash soap using a sponge or soft cloth. The sponge or cloth should be frequently soaked in the soap solution.

CAUTION

When using a commercial car wash product, observe the cautions specified by the manufacturer. Never use strong household detergents or soaps.

- 4) Once the dirt has been completely removed, rinse off the detergent with running water.
- 5) After rinsing, wipe off the vehicle body with a wet chamois or cloth and allow it to dry in the shade.
- 6) Check carefully for damage to painted surfaces. If there is any damage, "touch-up" the damage following the procedure below:
 1. Clean all damaged spots and allow them to dry.

2. Stir the paint and "touch-up" the damaged spots lightly using a small brush.
3. Allow the paint to dry completely.

CAUTION

If you use an automatic car wash, make sure that your vehicle's body parts, such as spoilers, cannot be damaged. If you are in doubt, consult the car wash operator for advice.

Waxing

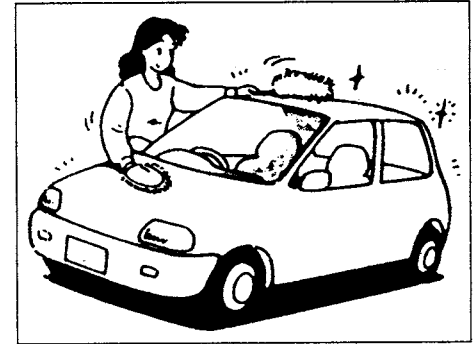

60B211S

After washing the vehicle, waxing and polishing are recommended to further protect and beautify the paint.

- Only use waxes and polishes of good quality.
- When using waxes and polishes, observe the precautions specified by the manufacturers.

MEMO

GENERAL INFORMATION

Vehicle Identification 10-1
Fuel Consumption (for Europe) 10-2

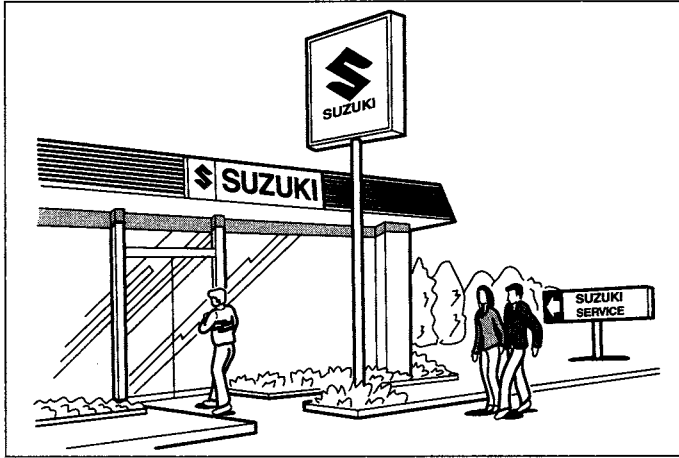

54G072

GENERAL INFORMATION

Vehicle Identification

Chassis Serial Number

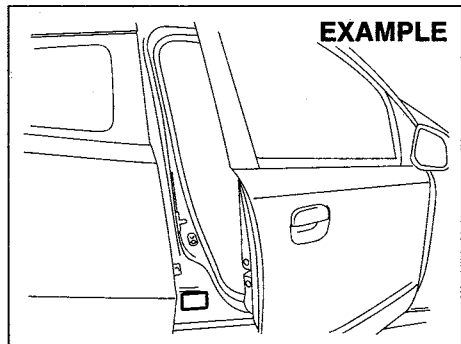

68KM077

The chassis and/or engine serial numbers are used to register the vehicle. They are also used to assist your dealer when ordering or referring to special service information. Whenever you have occasion to consult your SUZUKI dealer, remember to identify your vehicle with this number. Should you find the number difficult to read, you will also find it on the identification plate.

Engine Serial Number

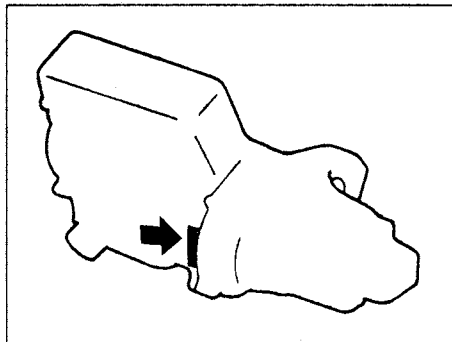

54G082

The engine serial number is stamped on the cylinder block as shown in the illustration.

Fuel Consumption (for Europe)

M/T: Manual transaxle

A/T: Automatic transaxle

		K10B
Urban (L/100km)/CO ₂ (g/km)	M/T	5.5/128
	A/T	6.7/156
Extra-urban (L/100km)/CO ₂ (g/km)	M/T	3.8/89
	A/T	4.5/103
Combined (L/100km)/CO ₂ (g/km)	M/T	4.4/103
	A/T	5.2/122

NOTE:

As these data are obtained under certain specific conditions, actual fuel consumption of your vehicle will be different from these data.

SPECIFICATIONS

NOTE:

Specifications are subject to change without notice.

M/T: Manual transaxle
A/T: Automatic transaxle

ITEM: Dimensions		UNIT: mm (in.)
Overall length		3500 (137.8)
Overall width		1600 (63.0)
Overall height		1470 (57.9)
Wheelbase		2360 (92.9)
Track	Front	1405 (55.3)
	Rear	1400 (55.1)
Ground clearance		150 (5.9)

ITEM: Mass (weight)		UNIT: kg (lbs)	1.0L
Curb mass (weight)	M/T	855 - 885 (1885 - 1940)	
	A/T	880 - 910 (1940 - 2006)	
Gross vehicle mass (weight) rating		1250 (2756)	
Gross axle mass (weight) rating	Front	700 (1543)	
	Rear	650 (1433)	

SPECIFICATIONS

ITEM: Engine	
Type	K10B (DOHC)
Number of cylinders	3
Bore	73.0 mm (2.87 in.)
Stroke	79.4 mm (3.13 in.)
Piston displacement	996 cm ³ (996 cc, 60.8 cu.in)
Compression ratio	11.0 : 1

ITEM: Electrical		
Standard spark plug	Iridium plug	NGK IKR6G11
Battery	12V 38B20R or 12V 55B24R	
Fuses	See "INSPECTION AND MAINTENANCE" section.	

ITEM: Lights		WATTAGE	BULB No.
Headlight		12V 60/55W	H4
Turn signal light	Front	12V 21W	PY21W
	Rear	12V 21W	PY21W
Side turn signal light		12V 5W	W5W
Position light		12V 5W	W5W
Brake/tail light		12V 21/5W	P21/5W
License plate light		12V 5W	W5W
Reversing light		12V 21W	P21W
Interior light		12V 8W	-
Front fog light		12V 55W	H11
Rear fog light		12V 21W	P21W
High mount stop light		12V 5W	W5W

SPECIFICATIONS

ITEM: Wheel and Suspension	
Tire size, front and rear	155/65R14
Rim size	155 tire: 14 x 4 1/2J
Tire pressures	For the specified tire pressure, see the Tire Information Label located on the driver's door lock pillar.
	When loaded up to 3 people, Eco Tire Pressure as listed below is recommended to achieve the smallest amount of fuel consumption possible.* Front 270 kPa (2.70 kg/cm ² , 39 psi) Rear 250 kPa (2.50 kg/cm ² , 36 psi)
Recommended snow tire	155/65R14
Recommended snow chain (for Europe)	Radial thickness: 10 mm, axial thickness: 10 mm

***NOTE:**

If loading over 3 people, follow the specified tire pressure listed on the Tire Information Label.

ITEM: Steering	
Toe-in	In 1.0 ± 1.0 mm (In 0.04 ± 0.04 in.)
Camber angle	$0^\circ \pm 1^\circ$
Caster angle	$3^\circ 50' \pm 2^\circ$

ITEM: Capacities (approx.)		
Coolant (including reservoir tank)	M/T	4.3 L (7.6 Imp pt)
	A/T	4.2 L (7.4 Imp pt)
Fuel tank		35 L (7.7 Imp gal)
Engine oil		2.9 L (5.1 Imp pt)(replacement with oil filter)
Transaxle oil	M/T	2.2 L (3.9 Imp pt)
	4-speed A/T	5.25 L (9.24 Imp pt)

SUPPLEMENT

For Australia 12-1

For Australia

Built Date

Built date is located on Vehicle Identification plate.

“Built Date” means – the calendar month and the year in which the body shell and power train sub-assemblies are conjoined and the vehicle is driven or moved from the production line.

Child Restraint

⚠ WARNING

Child restraint anchorages are designed to withstand only those loads imposed by correctly fitted child restraints. Under no circumstances are they to be used for adult seat belts, harnesses or for attaching other items or equipment to the vehicle.

Child Restraint Top Strap Anchor Brackets

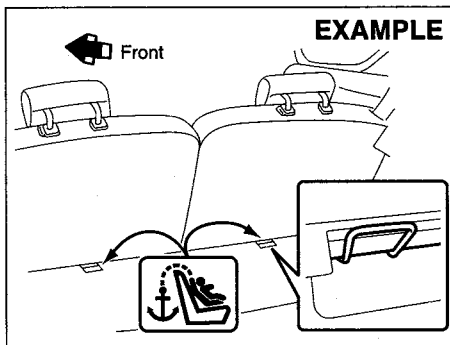

68KS017

Some child restraint systems require the use of a top strap. Top strap anchor brackets are provided in your vehicle at the locations shown in the illustrations. The number of the anchor bracket provided in your vehicle depends on the vehicle specification.

Please refer to the “Seat Belts and Child Restraint Systems” section in the “BEFORE DRIVING” section for details on securing your child.

Rear-facing Child Restraint



65D607

⚠ WARNING

Do not use a rearward facing child restraint on a seat protected by an air bag in front of it.

⚠ WARNING

Do not install a rear-facing child restraint in the front passenger's seat. If the passenger's front air bag inflates, a child in a rear-facing child restraint could be killed or severely injured. The back of a rear-facing child restraint would be too close to the inflating air bag.

If you must use a front-facing child restraint in the front passenger's seat, be sure to move the front passenger's seat as far back as possible.

Please refer to the "Seat Belts and Child Restraint Systems" section in the "BEFORE DRIVING" section for details on securing your child.

Air bag symbol (If equipped)

EXAMPLE



DO NOT place rear-facing child seat on this seat with airbag. DEATH OR SERIOUS INJURY can occur. The BACK SEAT with child restraint is the SAFEST place for children.

73K021

You may find this label on the sun visor.

Seat Belt Warning

Follow this WARNING in addition to the SEAT BELT instruction in this book.

⚠ WARNING

Seat belts are designed to bear upon the bony structure of the body, and should be worn low across the front of the pelvis or the pelvis, chest and shoulders, as applicable; wearing the lap section of the belt across the abdominal area must be avoided.

- Seat belts should be adjusted as firmly as possible, consistent with comfort, to provide the protection for which they have been designed. A slack belt will greatly reduce the protection afforded to the wearer.
- Care should be taken to avoid contamination of the webbing with polishes, oils and chemicals, and particularly battery acid. Cleaning may safely be carried out using mild soap and water. The belt should be replaced if webbing becomes frayed, contaminated or damaged.
- It is essential to replace the entire assembly after it has been worn in a severe impact even if damage to the assembly is not obvious.

(Continued)

⚠ WARNING

(Continued)

- Belts should not be worn with straps twisted.
- Each belt assembly must only be used by one occupant; it is dangerous to put a belt around a child being carried on the occupant's lap.

In the case where a "Seat Belt Assembly" incorporates an "Automatic Length Adjusting and Locking Retractor" or an "Emergency Locking Retractor".

⚠ WARNING

- No modifications or additions should be made by the user which will either prevent the seat belt adjusting devices from operating to remove slack, or prevent the seat belt assembly from being adjusted to remove slack.
- Referring to the SEAT BELT instruction in this book, adjust the seat belt so that the lap and sash portions of the *Seat Belt Assembly* fit as firmly as possible consistent with comfort.

Ignition Switch

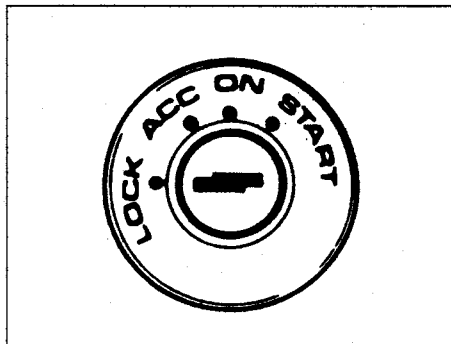

60B041

The ignition switch has the following four positions:

(LOCK)

This is the normal parking position. It is the only position in which the key can be removed.

Manual transaxle vehicles

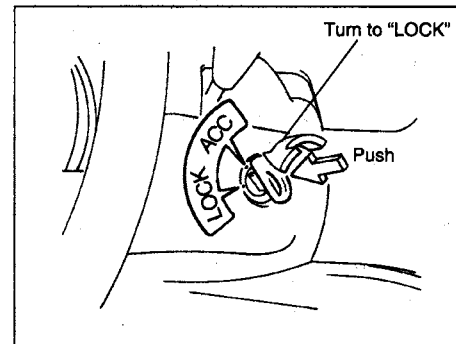

60G033

You must push in the key to turn it to the "LOCK" position. It locks the ignition, and prevents normal use of the steering wheel after the key is removed.

Automatic transaxle vehicles

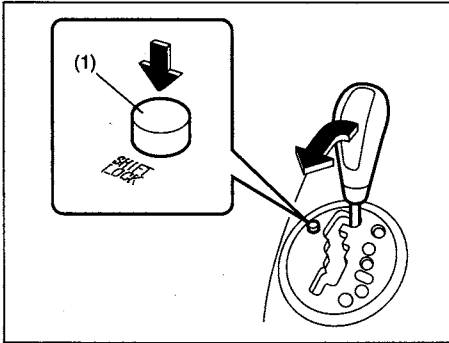

68KM038

The gearshift lever must be in the "P" (Park) position to turn the key to the "LOCK" position. It locks the ignition and prevents normal use of the steering wheel and gearshift lever.

If the gearshift lever can not be shifted out of "P" (Park) in the normal way, pushing the release button (1) in the "ON" or "ACC" position will permit movement of the gearshift lever out of "P" (Park). The gearshift lever can be moved back to "P" (Park) without pushing the release button (1).

To release the steering lock, insert the key and turn it clockwise to one of the other positions. If you have trouble turning the key to unlock the steering, try turning the steering wheel slightly to the right or left while turning the key.

(ACC)

Accessories such as the radio can operate, but the engine is off.

(ON)

This is the normal operating position. All electrical systems are on.

(START)

This is the position for starting the engine using the starter motor. The key should be released from this position as soon as the engine starts.

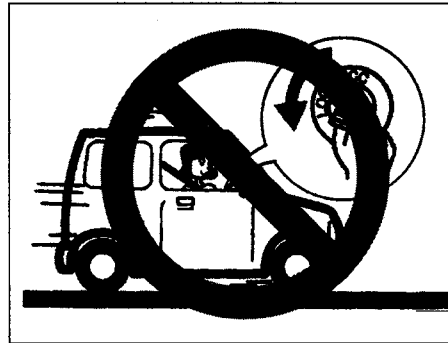

81A161

⚠ WARNING

- Never remove the ignition key while the vehicle is moving. The steering wheel will lock and you will not be able to steer the vehicle.
- Always remove the ignition key when leaving the vehicle even if a short time. Also do not leave children alone in a parked vehicle. Unattended children could cause accidental movement of the vehicle or could tamper with power windows or power sunroof. They also could suffer from heat stroke in warm or hot weather. These could result in severe injury or even death.

CAUTION

- Do not use the starter motor for more than 15 seconds at a time. If the engine does not start, wait 15 seconds before trying again. If the engine does not start after several attempts, check the fuel and ignition systems or consult your SUZUKI dealer.
- Do not leave the ignition switch in the "ON" position if the engine is not running as the battery will discharge.

Audio Systems

AM/FM CD PLAYER WITH CD CHANGER CONTROL

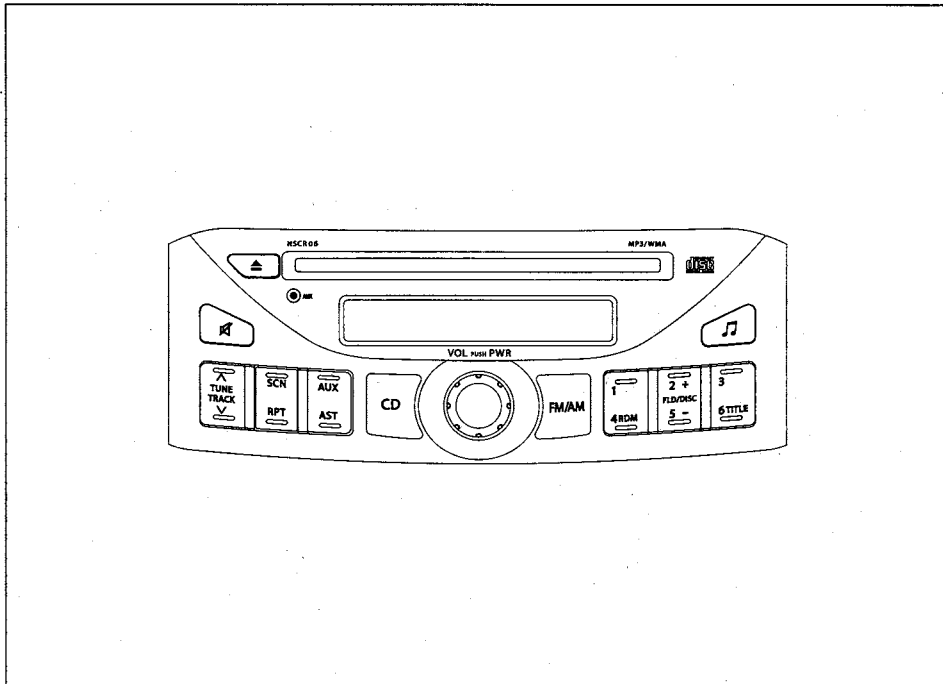

68KS005

Precautions

- When the inside of the car is very cold and the player is used soon after switching on the heater, moisture may form on the disc or the optical parts of the player and proper playback may not be possible. If moisture forms on the disc, wipe it off with a soft cloth. If moisture forms on the optical parts of the player, do not use the player for about one hour, this will allow the condensation to disappear normally.
- Driving on extremely bumpy roads which cause severe vibrations may cause sound to skip.
- This unit uses a precision mechanism. Even in the event that trouble arises, never open the case, disassemble the unit, or lubricate the rotating parts. Please bring the unit to an authorized SUZUKI dealer.

Cautions on Handling



52D274

This unit has been designed specifically for playback of compact discs bearing the mark (A).

No other discs can be played.

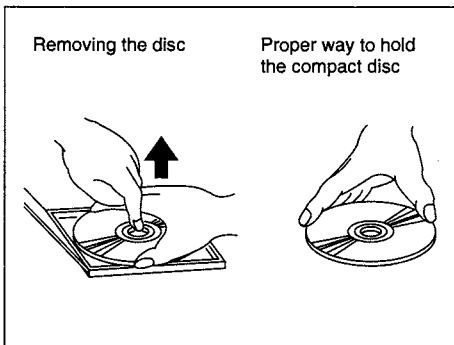

52D275

To remove the compact disc from its storage case, press down on the center of the case and lift the disc out, holding it carefully by the edges.

Always handle the compact disc by the edges.

Never touch the surface.

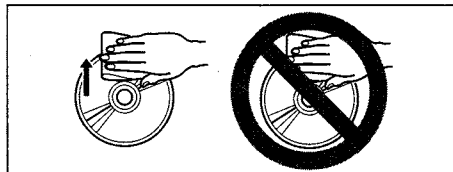

52D347

To remove fingerprints and dust, use a soft cloth, and wipe in a straight line from the center of the compact disc to the circumference.

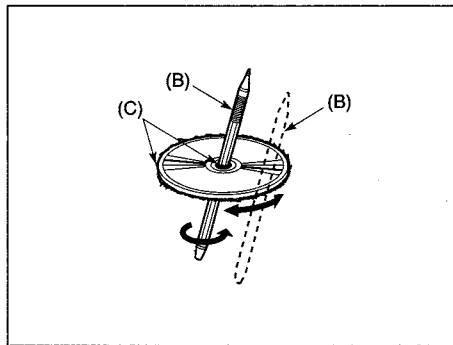

52D277

New discs may have some roughness around the edges. The unit may not work or the sound may skip if such discs are used. Use a ball-point pen (B), etc. to remove the roughness (C) from edges of the disc before insertion inside the unit.

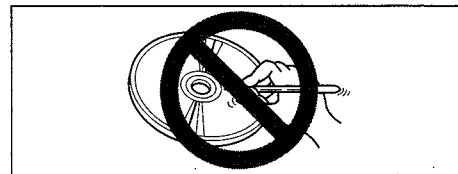

52D348

Never stick labels on the surface of the compact disc or mark the surface with a pencil or pen.

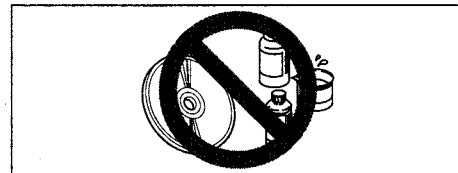

52D349

Do not use any solvents such as commercially available cleaners, anti-static spray, or thinner to clean compact discs.

OTHER CONTROLS AND EQUIPMENT



52D350

Do not use compact discs that have large scratches, are misshaped, or cracked, etc. Use of such discs will cause damage or prevent the system from operating properly.

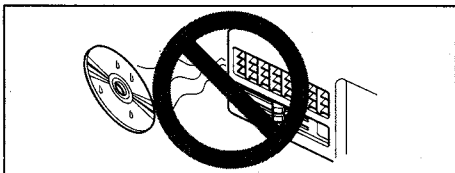

52D351

Do not expose compact discs to direct sunlight or any heat source.

NOTE:

- Do not use commercially available CD protection sheets or discs equipped with stabilizers, etc. These may get caught in the internal mechanism and damage the disc.
- CD-R/RW discs may not be able to playback in this unit due to the recording conditions.

Basic Operations

AM/FM CD PLAYER WITH CD CHANGER CONTROL

- (1) Power on/off knob
Volume control knob
- (2) Sound / Beep Tone button
- (3) Mute button

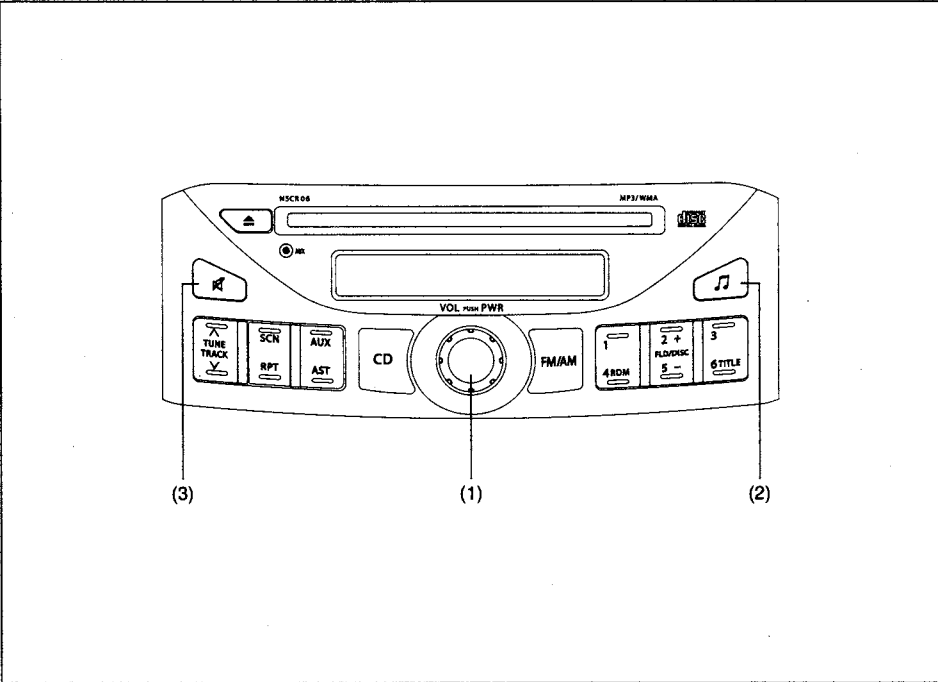

68KS006

OTHER CONTROLS AND EQUIPMENT

Turning Power on/off

Press the Power on/off knob (1).

The unit starts in the function mode it was in when the power was turned off last.

Adjusting the volume

Turn the Volume control knob (1).

Turning it clockwise increases the volume; turning it counterclockwise decreases the volume.

NOTE:

While driving, adjust the volume to an extent that sound and/or noise coming from outside the car can be heard.

Mute

1) Press the Mute button (3).

Press the Mute button (3) again, it returns to the original volume.

Adjusting bass/treble/balance/fader

1) Press the Sound button (2).

Each time it is pressed, sound adjustment is changed as follows:

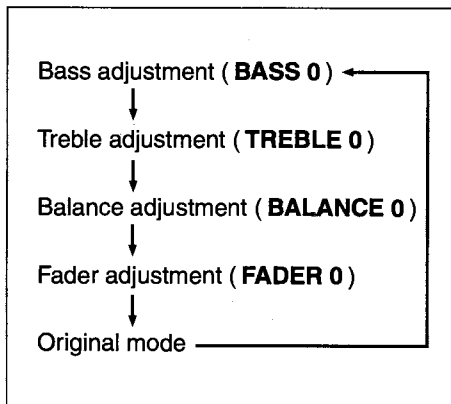

68KH108

2) Turn the Volume control knob (1) to adjust the sound.

Listening to the Radio
AM/FM CD PLAYER WITH CD CHANGER CONTROL

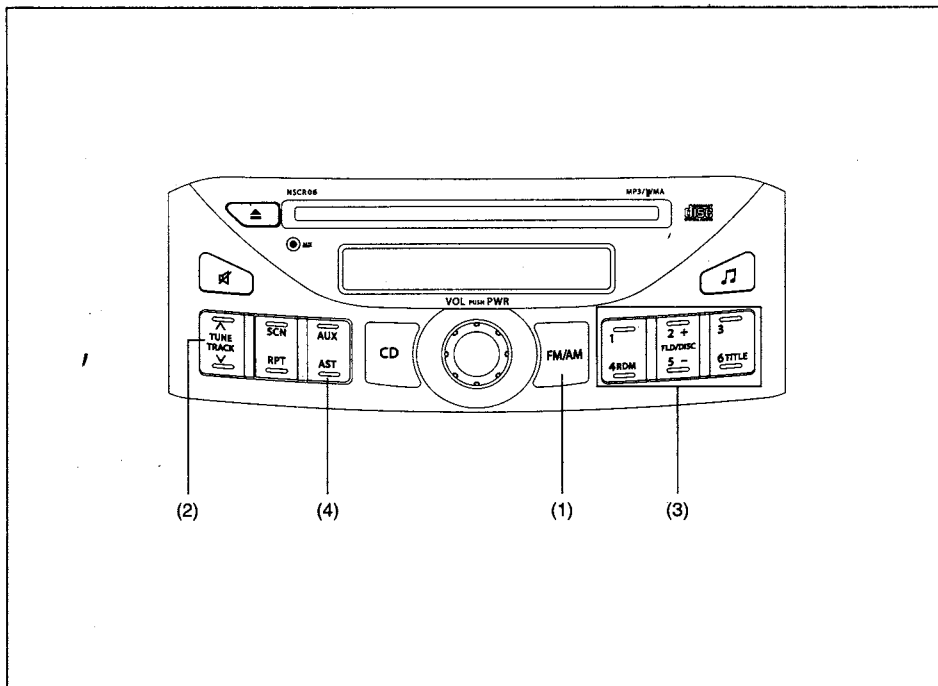

68KS007

Display

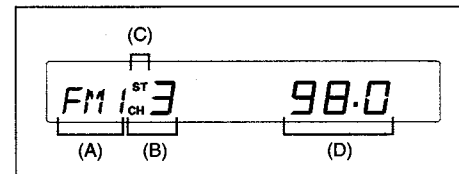

68KH111

- (1) Band switch button
- (2) Tune / Track button
- (3) Preset buttons
- (4) AST button

- (A) Band
- (B) Preset channel number
- (C) Stereo indicator
- (D) Frequency

OTHER CONTROLS AND EQUIPMENT

Selecting the reception band

Press the Band switch button (1). Each time the button is pressed, the reception band is switched as follows:

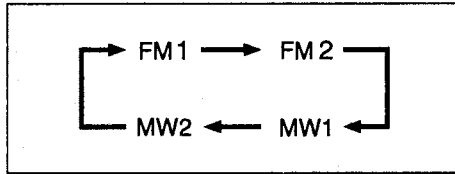

68KS008

Seek tuning

Press longer Tune / Track button (2) to up or down.

The unit stops searching for a station at a frequency where a broadcast station is available.

Manual tuning

Press Tune / Track button (2) to up or down.

The frequency being received is displayed.

Preset memory

- 1) Select the desired station.
- 2) Select the Preset button (3) to which you want to store the station and press and hold the button for more than 1.5 seconds.

Auto store

Press and hold the AST button (4) for more than 1.5 seconds.

6 stations in total are automatically stored to the Preset buttons (3) in sequential order, starting from the lower frequencies.

NOTE:

- If no station can be received after Auto Store is performed, “- -” appears in the display.
- If fewer than 6 stations can be received, the system will memorize as many stations as possible, then select the strongest one.

Radio Reception

Radio reception can be affected by environment, atmospheric conditions, or radio signal's power and distance from the station. Nearby mountains and buildings may interfere or deflect radio reception, causing poor reception. Poor reception or radio static can also be caused by electric current from overhead wires or high voltage power lines.

Listening to a CD



52D274

- CDs or CD-ROMs carrying no mark (A) cannot be used.
- Some discs previously recorded in CD-R/CD-RW format may not be used.

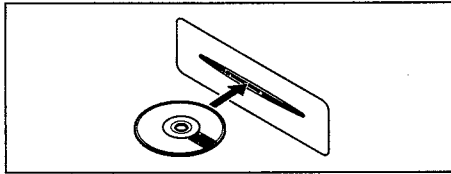

52D291

- A CD is inserted with its label facing upward.
- When there is a CD already loaded in the unit, another CD cannot be loaded at the same time. Do not use force when inserting the CD into the CD insertion slot.
- If a blank disc (non recorded CD-R) is loaded in the unit, the disc will be ejected.

CAUTION

- **Never insert your finger or hand into the CD insertion slot. Never insert foreign objects.**
- **Never insert a CD with glue coming out from adhesive tape or a rental CD label or with a trace indicating that adhesive tape or a rental CD label has been removed. This may cause the CD not to eject or result in a malfunction.**

OTHER CONTROLS AND EQUIPMENT

AM/FM CD PLAYER WITH CD CHANGER CONTROL

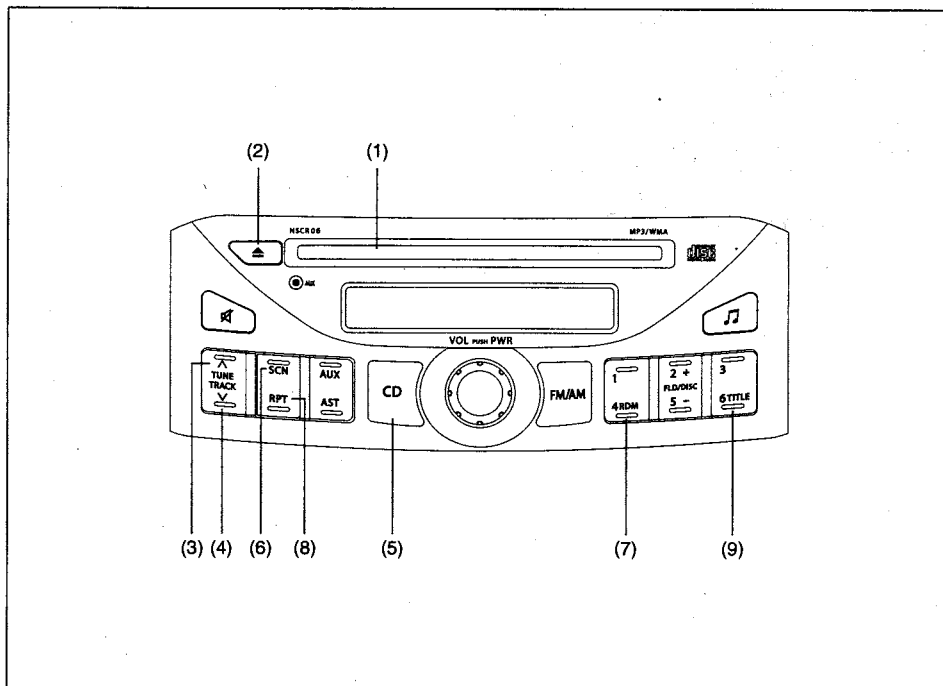

68KS009

Display

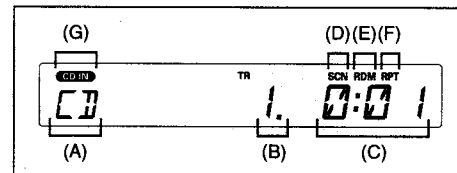

68KH114

- (1) CD slot
- (2) Eject button
- (3) Track up / Fast forward button
- (4) Track down / Fast rewind button
- (5) CD button
- (6) Scan button
- (7) Random button
- (8) Repeat button
- (9) Disc title / Track title

- (A) Mode indicator
- (B) Track number
- (C) Play time
- (D) Scan indicator
- (E) Random indicator
- (F) Repeat indicator
- (G) Disc indicator

NOTE:

About Single CDs (8 cm CDs)

- No adapter is required to play a single CD.
- A single CD is inserted from the center of the CD insertion slot.
- Since an ejected single CD is not automatically reloaded, be sure to remove the ejected single CD.

Loading a CD

Insert a CD in the CD slot (1).

When a CD is loaded, play starts and the CD indicator (A) lights.

Ejecting a CD

Press the Eject button (2).

Unit will return to previously tuned radio station.

If you left a CD ejected for a period of about 10 seconds, it will be automatically drawn inside the unit. (Auto reload function)

CAUTION

If you forcefully try to push an ejected CD inside the unit before auto reloading, the disc surface might be scratched.

Listening to a CD

When a CD is inserted, it is automatically played back.

When a CD is already inside the unit, press the CD button (5) to play back the CD. When a CD is inside the unit, the CD indicator (G) is lit on the display unit.

Selecting a track

- Press the Track up button (3) to listen to the next track.
- Press the Track down button (4) twice to listen to the previous track.
When the Track down button (4) is pressed once, the track being currently played will return to the beginning.

Fast forwarding/Rewinding a track

- Hold in the Fast forward button (3) to advance a track rapidly.
- Hold in the Fast rewind button (4) to rewind a track rapidly.

Repeat play

Press the Repeat button (8).

Each time the button is pressed, repeat play mode changes as follows:

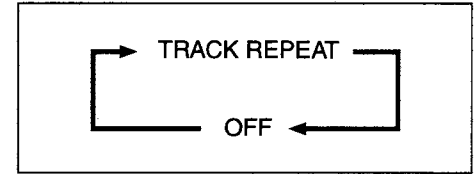

68KH115

- Track repeat
Repeat indicator (F) lights up.
The track currently being played is played repeatedly.

OTHER CONTROLS AND EQUIPMENT

Random play

Press the Random button (7).
Each time the button is pressed, random play mode changes as follows:

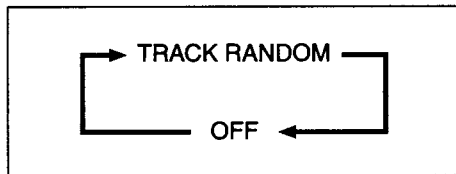

68KH116

- Track random
Random indicator (E) lights up.
The tracks are played randomly.

Scan play

Press the Scan button (6).
Each time the button is pressed, scan play mode changes as follows:

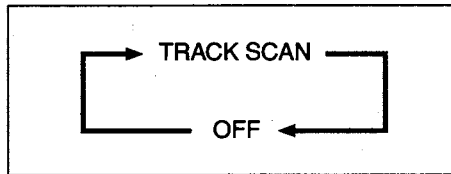

68KH117

- Track scan
Scan indicator (D) lights up.
Each track is sequentially played first 10 seconds.

Displaying CD Title

Press the Disc title / Track title button (9).
Each time this button is pressed, display will change as follows:

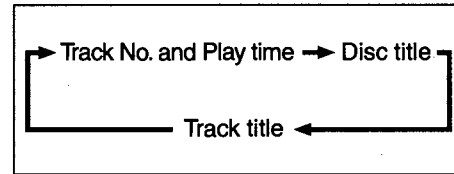

68KH118

Forwarding a Title

When Disc title or Track title is displayed, press longer the Disc title / Track title button (9) to display the remaining characters if it is more than 8 characters. A total of 16 characters can be displayed.

* If the number of characters is 8 or less, display does not scroll.

Listening to an MP3/WMA Disc
AM/FM CD PLAYER WITH CD CHANGER CONTROL

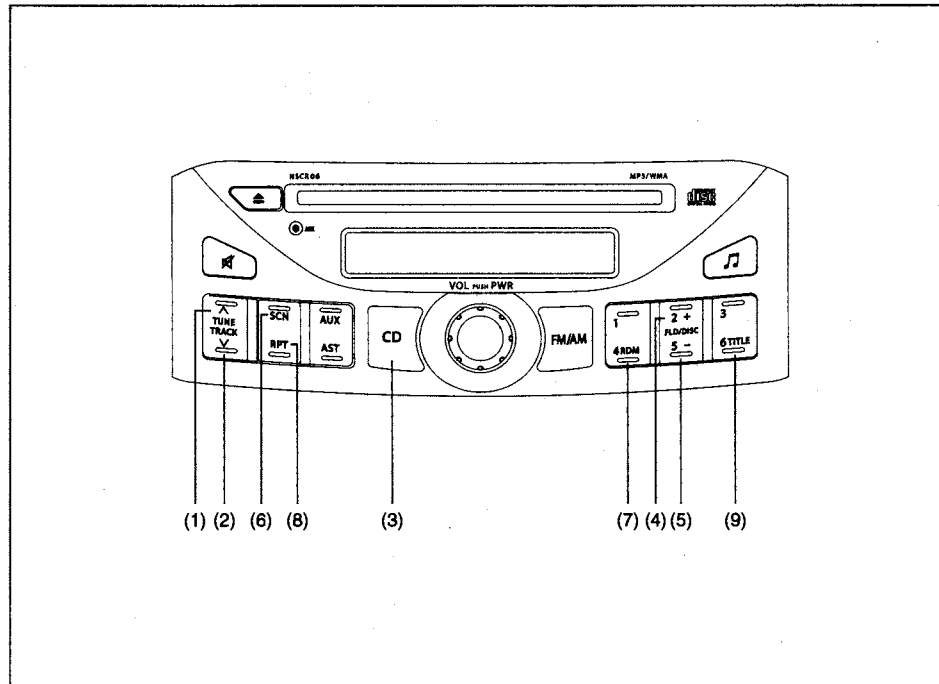

Display

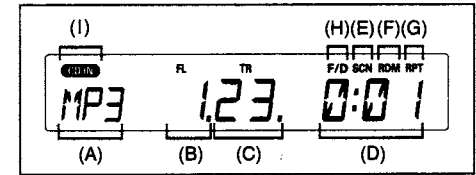

68KS011

- (1) Track up / Fast forward button
- (2) Track down / Fast rewind button
- (3) CD button
- (4) FLD / Disc up button
- (5) FLD / Disc down button
- (6) Scan button
- (7) Random button
- (8) Repeat button
- (9) Disc title / Track title button

- (A) Mode indicator
- (B) Folder number
- (C) Track number
- (D) Play time
- (E) Scan indicator
- (F) Random indicator
- (G) Repeat indicator
- (H) Folder indicator
- (I) Disc indicator

68KS010

OTHER CONTROLS AND EQUIPMENT

What is MP3/WMA?

MP3 (MPEG1/2 Audio Layer-III) and WMA (Windows Media™ Audio) are the compression formats of digital audio. The former is developed by MPEG (Motion Picture Experts Group), and the latter is developed by Microsoft Corporation. Using these compression formats, you can record the contents of about 10 music CDs on a single CD media (This figures refer to data recorded on a 650 MB CD-R or CD-RW at a fixed bit rate of 128 kbps and a sampling frequency of 44.1 kHz).

Points to remember when making MP3/WMA files

Common

- High bit rate and high sampling frequency are recommended for high quality sounds.
- Selecting VBR (Variable Bit Rate) is not recommended because playing time is not displayed properly and sound may be skipped.
- The playback sound quality differs depending on the encoding circumstances. For details, refer to the user manual of your own encoding software and writing software.

MP3

- It is recommended to set the bit rate to "128 kbps or more" and "fixed".

WMA

- It is recommended to set the bit rate to "64 kbps or more" and "fixed".
- Do not set the copy protect attribute on the WMA file to enable this unit to play back.

NOTE:

Never assign the ".mp3", or ".wma" file name extension to a file that is not in the MP3/WMA format. This may not only produce noise from the speaker damage, but also damage your hearing.

Recording MP3/WMA files on a CD media

- If CD-DA files are on the same disc as MP3 or WMA files, the songs may not play in the intended order, or some songs may not play at all.
- When storing MP3 data and WMA data on the same disc, use different folders for each data.
- Do not record files other than MP3/WMA files and unnecessary folder on a disc.
- The name of an MP3/WMA file should be added by rules as shown in the following descriptions and also comply with the rules of each file system.
- The file extension ".mp3" or ".wma" should be assigned to each file depending on the file format.
- You may encounter trouble in playing MP3/WMA files or displaying the information of MP3/WMA files recorded with certain writing software or CD recorders.

- This unit does not have a play list function.
- Although Multi-session recording is supported, the use of Disc-at-Once is recommended.

Compression formats

MP3

- Bit rate
 - MPEG1 Audio Layer III : 32 k – 320 kbps
 - MPEG2 Audio Layer III : 8 k – 160 kbps
- Sampling frequency
 - MPEG1 Audio Layer III : 44.1 k/48 k/32 kHz
 - MPEG2 Audio Layer III : 22.05 k/24 k/16 kHz

WMA (Ver.7, Ver.8)

- Bit rate
 - 32 k – 192 kbps
- Sampling frequency
 - 44.1 k/48 k/32 kHz

Supported file systems

ISO 9660 Level 1/Level 2/Level 3, Joliet, Romeo

Maximum number of files/folders

- Maximum number of files:
 - CD Player: 512 (files + folders)
- Maximum number of files in one folder: 255
- Maximum depth of trees: 8
- Maximum number of folders: 255 (Root folder is included.)

MP3/WMA MODE**Selecting a folder**

Press the FLD/Disc up button (4) to select the next folder.

Press the FLD/Disc down button (5) to select preceding folder.

It may take a few moment until a folder is selected.

Repeat Play

- **Track Repeat**
Press the Repeat button (8). The Repeat indicator (G) lights up. The current track is played repeatedly.
- **Folder Repeat**
Press the Repeat button (8) for more than 1.5 seconds. The Folder Repeat indicator (H) (G) lights up. The current folder is played repeatedly.

To cancel the track repeat or folder repeat, press the Repeat button (8) to change the repeat play mode to OFF.

Random Play

- **Track Random**
Press the Random button (7). The Random indicator (F) lights up. The tracks on the current disc is played randomly.
- **Folder Random**
Press the Random button (7) for more than 1.5 second. The Folder Random indicator (H) (F) lights up. All the tracks in the current folder is played randomly.

To cancel the track random or folder random press the Random button (7) to change.

Scan Play

- **Track Scan**
Press the Scan button (6). The Scan indicator (E) lights up. The first 10 seconds of each track on the current disc is played.
- **Folder Scan**
Press the Scan button (6) for more than 1.5 seconds. The Folder Scan indicator (H) (E) lights up. Play the first 10 seconds of first track in each folder and keep moving to next folder.

To cancel the track scan or folder scan press Scan button (6) to change the scan play mode to OFF.

Selecting a track

- Press the Track up button (1) to listen to the next track.
- Press the Track down button (2) twice to listen to the previous track.
When the Track down button (2) is pressed once, the track currently being played will start again at the beginning.

Fast forwarding/Rewinding a track

- Hold in the Fast forward button (1) to advance a track rapidly.
- Hold in the Fast rewind button (2) to rewind a track rapidly.

Displaying CD Title

- Press Disc title / Track title button (9). Each time this button is pressed, display will changed as follows.

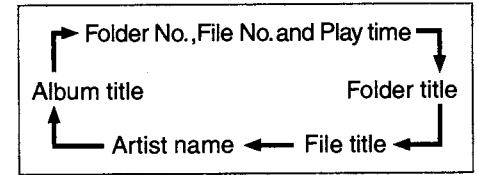

68KH121

Forwarding a Title

When Folder Title, File Title, Artist Name and Album Title is displayed, press longer the Disc title / Track title button (9) to display the remaining characters if it is more than 8 characters.

A total of 16 characters can be displayed. If the number of characters is 8 or less, display does not scroll.

OTHER CONTROLS AND EQUIPMENT

Listening to an AUXILIARY AUDIO SOURCE AM/FM CD PLAYER WITH CD CHANGER CONTROL

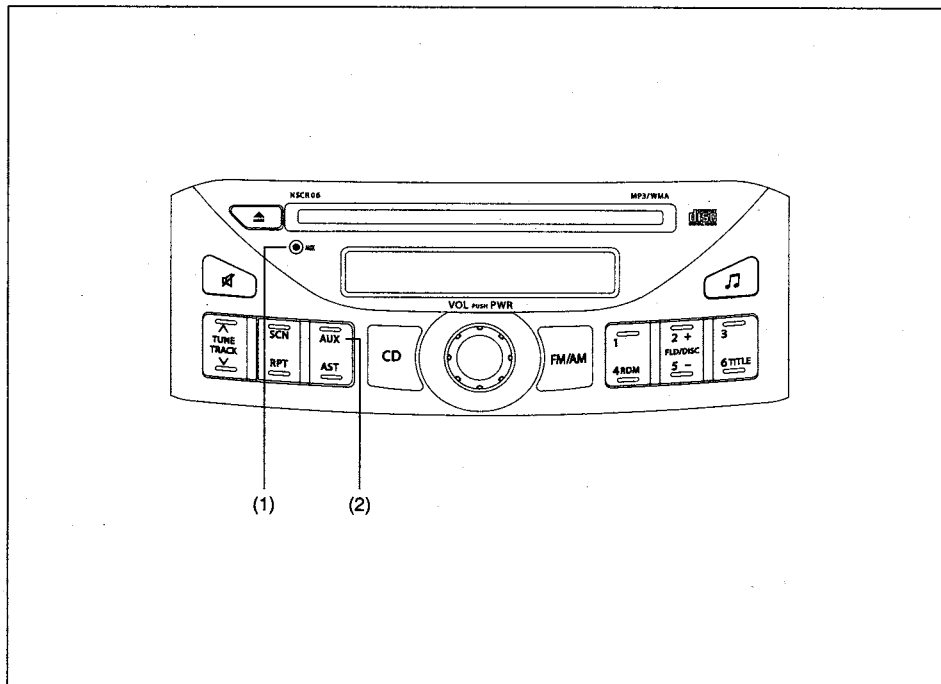

68KS015

Display

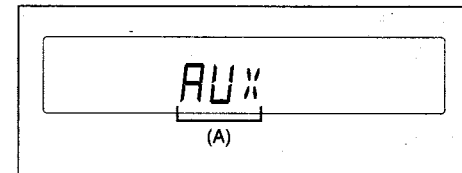

68KS016

- (1) Aux in jack
- (2) Aux button

(A) Mode indicator

NOTE:

- *Before connection, set the volume for the unit to 0 (When Aux mode is selected) and also keep the volume of the auxiliary audio source within a range that will not cause distortion.*
- *When the audio source is turned off, noise may be emitted. Be sure to turn off the unit or switch to another mode before turning off the audio source.*
- *When in Aux mode, the volume setting is different from another mode.*

Aux Mode

Press the Aux button (2).

The Aux indicator (A) lights up.

The unit reproduces audio by auxiliary audio source such as portable media player.

INDEX

Symbols

“AIR BAG” Light	2-40
“ESP” (Electronic Stability Program) Warning Light	2-41
“ESP” Warning Light.....	3-16
“TCSS OFF” Indicator Light	2-44, 3-16

Numerics

4-Speed Automatic Transaxle	3-9
-----------------------------------	-----

A

Accelerator Pedal	3-6
Accessory Socket.....	5-33
Adding Coolant	7-12
Adjusting Seat Position	2-10
Adjusting Seatbacks	2-11
Air Cleaner.....	7-12
Air Conditioning System.....	7-34
All Seat Belts.....	2-16
Anti-Lock Brake System (ABS)	3-12
Anti-Lock Brake System (ABS) Warning Light	2-41
Anti-Lock Braking System (ABS).....	3-15
Anti-Theft Feature.....	5-25
Audio Systems.....	5-9
Automatic Transaxle (AT) Fluid.....	7-16

B

Basic Operations	5-12
Battery	7-22
Brake Assist System	3-12
Brake Fluid	7-17
Brake Pedal	3-6, 7-18
Brake System Warning Light.....	2-39

Brakes	7-17
Braking.....	3-11
Bulb Replacement.....	7-26

C

Cable control clutch.....	7-15
Catalytic Converter	4-1
Central Door Locking System.....	2-3
Changing Engine Oil and Filter.....	7-9
Changing Wheels	8-4
Charging Light.....	2-42
Chassis Serial Number	10-1
Child Restraint.....	2-21
Child Restraint System for EU Countries	2-21
Child Restraint Systems.....	2-18
Child-Proof Locks (rear door).....	2-3
Clock	2-47
Clutch Pedal	3-6, 7-15
Compact Spare Tire	7-21
Coolant Level Check.....	7-11
Coolant Replacement	7-12
Corrosion Prevention	9-1
Cup Holder.....	5-34

D

Daily Inspection Checklist.....	3-1
Day time running light control	2-49
Door Locks	2-2
Drive Belt	7-7
Driver's Seat Belt Reminder.....	2-17
Driving on Hills.....	4-3
Driving on Slippery Roads	4-4

INDEX

E

Electric Power Steering Light.....	2-42
Electric Window Controls	2-7
Electronic Stability Program (ESP®).....	3-14
Emergency Locking Retractor (ELR).....	2-15
Engine Coolant	7-11
Engine Hood.....	5-31
Engine Oil and Filter.....	7-7
Engine Oil Consumption.....	3-2
Engine Serial Number	10-1
Exhaust Gas Warning.....	3-1

F

Flat Tire Repair Kit.....	8-5
Fluid Level Check	7-16
For Australia.....	12-1
Frame Hooks	5-35
Front Air Bags.....	2-32
Front Fog Light Switch.....	2-50
Front Seats	2-10
Fuel Consumption (for Europe).....	10-2
Fuel Filler Cap	5-30
Fuel Gauge	2-46
Fuel Recommendation	1-1
Fuses	7-24
Fuses in the Engine Compartment	7-24
Fuses under the Dash Board.....	7-25

G

Gasoline/Ethanol blends.....	1-1
Gasoline/Methanol blends	1-1
Gear Oil.....	7-14
Gear Oil Change.....	7-15

Gear Oil Level Check	7-15
Glove Box	5-33

H

Hazard Warning Switch	2-52
Headlight Leveling Switch.....	2-50
Heated Rear Window Switch.....	2-9
Heating and Air Conditioning System.....	5-1
Heating System	5-2
High Engine Coolant Temperature Warning Light (red color)	2-43
Highway Driving	4-3
Horn.....	2-55
How the ABS Works.....	3-14

I

If the Engine is Flooded.....	8-11
If the Engine Overheats	8-11
If the Starter Does Not Operate.....	8-11
If You Can Not Shift Automatic Transaxle Gearshift Lever Out of "P" (PARK)	3-10
If Your Vehicle Gets Stuck	4-5
Ignition Key Reminder	2-2
Ignition Switch.....	3-3
Immobilizer System	2-1
Immobilizer System Light.....	2-43
Improving Fuel Economy	4-2
Information Display.....	2-46
Inside Rearview Mirror.....	2-8
Installation of Child Restraint with Top Strap	2-28
Installation of Radio Frequency Transmitters.....	5-9
Installation with ISOFIX type Anchorages	2-26
Installation with Lap-Shoulder Seat Belts	2-24

Instrument Cluster	2-38	O	
Interior Light Switch	5-32	Odometer	2-47
iPod/USB adaptor	5-27	Oil Level Check	7-8
J		Oil Pressure Light	2-42
Jacking Instructions	8-3	Open Door Warning Light	2-43
Jump Starting Instructions	8-9	Outside Rearview Mirrors	2-9
K		P	
Keyless Entry System Transmitter	2-4	Parking Brake	7-19
Keys	2-1	Parking Brake Lever	3-5
L		Pedal	3-6
Lap-Shoulder Belt	2-15	Periodic Maintenance Schedule	7-2
Lighting Control Lever	2-48	Power Assisted Brakes	3-12
Lighting Operation	2-49	R	
Lights "On" reminder	2-49	Radio Antenna	5-8
Listening to a CD	5-18	RDS (Radio Data System)	5-16
Listening to an MP3/WMA Disc	5-22	Rear Fog Light Indicator Light	2-44
Listening to the Radio	5-14	Rear Fog Light Switch	2-50
Low Fuel Warning Light	2-40	Rear Seats	2-11
Luggage Area Cover	5-34	Rear Window Wiper/Washer Switch	2-54
M		Refill with Oil and Check for Leaks	7-10
Main Beam (high beam) Indicator Light	2-44	Refilling	7-8
Maintenance	5-8	Replace the Oil Filter	7-10
Maintenance Recommended under Severe Driving Conditions	7-5	Running-in	4-1
Maintenance Schedule	7-2	S	
Malfunction Indicator Light	2-41	Seat Belt Hanger	2-17
Manual Heating and Air Conditioning System	5-5	Seat Belt Inspection	2-18
Manual Transaxle	3-8	Seat Belt Pretensioner System	2-29
Manual Transaxle Oil	7-14	Seat Belt Warning Light	2-40
Mirrors	2-8	Seat Belts and Child Restraint Systems	2-13
		Selection of Coolant	7-11
		Side Air Bags and Side Curtain Air Bags	2-34

INDEX

Side Door Locks	2-2	Turn Signal Operation	2-51
SLIP Indicator Light.....	2-44, 3-15	U	
Spark Plugs	7-13	Using the Transaxle	3-8
SPECIFICATIONS	11-1	V	
Specified Fluid	7-16	Vehicle Cleaning	9-2
Specified Oil	7-7	Vehicle Identification	10-1
Speedometer	2-45	Vehicle Loading.....	6-1
Stability Control System	3-14	W	
Starting the Engine.....	3-7	Warning and Indicator Lights	2-39
Steering	7-19	Washing	9-3
Sun Visor.....	5-32	Waxing	9-4
Supplemental Restraint System (air bags).....	2-31	Windows	2-7
T		Windshield Washer	2-53
Tachometer	2-45	Windshield Washer Fluid	7-34
Tailgate	2-4	Windshield Wiper and Washer Lever	2-52
Tilt Steering Lock Lever	2-54	Windshield Wipers	2-53
Tire Chains	4-4	Wiper Blades	7-31
Tire Changing Tool	8-1		
Tire Inspection	7-20		
Tire Rotation.....	7-21		
Tires	7-19		
Towing	8-10		
Towing Your Vehicle (recreational towing).....	6-6		
Traction Control System	3-14		
Trailer hitch installation points	6-6		
Trailer Towing	6-1		
Transaxle Selector Position Indicator	2-45		
Transaxle Warning Light.....	2-43		
Trip meter	2-47		
Turn Signal Control Lever.....	2-51		
Turn Signal Indicators.....	2-43		

Declaration of Conformity in accordance with Directive 1999/5/EC (R&TTE Directive)

Manufacturer: Siemens VDO Automotive AG
Body & Chassis Electronics

Address: Dep. SV C BC P2 RF TG
Siemensstrasse 12
D-93055 Regensburg
Germany

Product type designation: 5WK4 9182 and 5WK4 9181

Intended use: Vehicle immobilisation system

The product mentioned above complies with the essential requirements and other relevant provisions of Directive 1999/5/EC, when used for its intended purpose:

Health and safety pursuant to §3.1.a: *Applied standard(s):*
EN 60950: 2000

Electromagnetic compatibility pursuant to § 3.1.b: *Applied standard(s):*
EN 301 489-1,-3: V1.4.1 (2002-08)

Efficient use of spectrum pursuant to § 3.2: *Applied standard(s):*
EN 300 330-1: V1.3.2 (2002-12)

The following marking applies to the above mentioned product:



Siemens VDO Automotive AG

Regensburg, 2004-06-28

J. V. Tarabbi
.....
Jean-Francois Tarabbi
Executive Vice President
Body & Chassis Electronics
Operations

Norbert Müller
.....
Norbert Müller
Vice President
Wireless Products and Modules



Continental Automotive Components (India) Private Limited

To
Maruti Suzuki India Ltd,

Body and Security
Torsten Kreiling
Business Unit Head
Phone +91 9632222873
Fax +91-90- 66115-604
Torsten.kreiling@continental-corporation.com

Date
JUN 9, 2009

Your message dated

Our Reference

Your reference

Declaration of Conformity

I, the undersigned, declare that

The immobilizer 5WK49997 (33970M68K10) uses the same schematic, assembly and PCB as the immobilizer 5WK49946(33970M68K00).

The new type designation was necessary due to localization of parts and a different label & part no is used for carry forwarding the country homologation.

The modification does not influence the RF characteristics of the device
The immobilizer 5WK49946 (33970M68K00) has been homologated for countries (along with respective certificate no's) as per the attached Annexure

As 5WK49997(33970M68K10) is same as that of 5WK49946 (33970M68K00).
Thus there is no need for rehomologation as per applicable rules to above mentioned countries.

Sincerely

Torsten Kreiling
Head of Body and Security India
Continental Automotive Components (India) Private Limited

Continental Automotive Components (India) Private Limited
A-39, Bommarala's Industrial Area
Phase 1, Houra Road
Bangalore - 560 089

Phone +91 80 2611 5100
Fax +91 80 2611 5115
www.continental-corporation.com

Board of Directors
Dr. Arnošt Čadež
Managing Director
Chairman of General Board
Director

Executive Board:
Dr. Kai-Ingo Voigt
Chairman
Dr. Frank-Jürgen Meise
Hans-Gertard Wenz

OMRON







OMRON Corporation
6368 NENJO-ZAKA OKUSA
KOMAKI-CITY
AICHI
485-0802 JAPAN

DECLARATION of CONFORMITY

We, OMRON Corporation, hereby declare that this keyless entry systems ,model KL3,KL4,50J7,R68K0 are in compliance with the essential requirements and other relevant provisions of Directive 1999/5/EC.

CE

BATTERY LABEL SYMBOL MEANINGS

	No smoking, no naked flames, no sparks		Battery acid
	Shield eyes		Note operating instructions
	Keep away from children		Explosive gas

Prepared by
MARUTI SUZUKI INDIA LIMITED

Service Division
August, 2010

Part No. 99011M68K03-02E
Printed in India

SERVICE STATION INFORMATION

Fuel recommendation:

See page 1-1

Engine oil recommendation:

Gasoline engine:

Quality: SG, SH, SJ, SL or SM

Viscosity: SAE **0W-20**, 5W-30, 10W-30, 10W-40

For further details, see "Engine Oil and Filter" in the "INSPECTION AND MAINTENANCE" section.

Brake fluid:

DOT3 (SAE J1703) or DOT4 (SAE J1704)

Automatic transaxle fluid:

SUZUKI ATF 3317 or Mobil ATF 3309

Tire cold pressure:

See the "Tire Information Label" located on the driver's door lock pillar.



99011M68K03-02E

English

SUZUKI MOTOR CORPORATION Part No.99011M68K03-02E August, 2010



Printed in India