



XC90

OWNER'S MANUAL

WEB EDITION





WELCOME TO THE WORLD-WIDE FAMILY OF VOLVO OWNERS.

We trust that you will enjoy many years of safe driving in your Volvo, an automobile designed with your safety and comfort in mind. We encourage you to familiarize yourself with the equipment descriptions and operating instructions in this manual.

We also urge you and your passengers to wear seat belts at all times in this (or any other) vehicle. And, of course, please do not operate a vehicle if you may be affected by alcohol, medication or

any impairment that could hinder your ability to drive.

Your Volvo is designed to meet all applicable federal safety and emission standards. If you have any questions regarding your vehicle, please contact your Volvo retailer or see the section "Contacting Volvo" in this manual's "Introduction" chapter for information on getting in touch with Volvo in the United States and Canada.





00 Introduction

Important information.....	8
Environment.....	13
Important warnings.....	14



01 Safety

Occupant safety.....	18
Reporting safety defects.....	19
Seat belts.....	20
Supplemental Restraint System.....	23
Front airbags.....	24
Occupant Weight Sensor.....	28
Side impact protection airbags.....	32
Inflatable Curtain.....	34
Whiplash Protection System.....	36
Child safety.....	38
Child restraint systems.....	41
Infant seats.....	43
Convertible seats.....	45
Booster cushions.....	48
ISOFIX/LATCH lower anchors.....	49
Top tether anchors.....	51
Integrated booster cushion.....	52



02 Instruments and controls

Instrument overview.....	56
Instrument panel.....	58
Information display.....	62
Center console buttons.....	64
Steering wheel adjustment.....	66
Lighting panel.....	67
Manually unlocking the fuel filler door.....	70
Left-side steering wheel lever.....	71
Right-side steering wheel lever.....	72
Hazard warning flashers.....	75
Trip computer.....	76
Cruise control.....	78
12-volt sockets.....	80
Hood/tailgate.....	81
Power windows.....	82
Mirrors.....	84
Power moonroof.....	87
HomeLink® Wireless Control System*.....	89



03 Climate

Climate control system – general information.....	94
Air distribution.....	96
Electronic climate control (ECC).....	98

03



04 Interior

Front seats.....	104
Rear seats.....	108
Interior lighting.....	111
Storage compartments.....	114
Securing cargo.....	119

04



05 Locks and alarm

Remote keys and key blades.....	126
Locking and unlocking.....	130
Child safety locks.....	132
Alarm.....	133

05



06 Starting and driving

General information.....	138
Fuel requirements.....	139
Refueling.....	141
Starting the vehicle.....	143
Ignition switch and steering wheel lock..	145
Economical driving.....	146
Difficult driving conditions.....	147
Automatic transmission.....	149
Jump starting.....	152
All Wheel Drive*.....	153
Brake system.....	154
Parking brake.....	157
Stability system.....	158
Front/rear park assist*.....	160
Towing.....	162
Towing a trailer.....	164
Detachable trailer hitch.....	167
Load carriers (accessory).....	168
Cold weather precautions.....	169
Before a long distance trip.....	170
Blind Spot Information System*.....	171



07 Wheels and tires

General information.....	178
Tire inflation	181
Tire inflation pressure table.....	183
Tire designations.....	184
Glossary of tire terminology.....	186
Vehicle loading.....	187
Uniform Tire Quality Grading.....	189
Snow chains, snow tires, studded tires..	190
Temporary spare.....	191
Tire Sealing System	192
Changing wheels.....	198
Tire Pressure Monitoring System (TPMS)	203



08 Car care

Washing and cleaning the vehicle.....	208
Paint touch up.....	213





09 Maintenance and servicing

Volvo service.....	216
Maintaining your vehicle.....	217
Working on your vehicle.....	219
Engine compartment.....	221
Engine oil.....	222
Fluids.....	224
Wiper blades.....	226
Battery.....	227
Replacing bulbs.....	230
Fuses.....	238



10 Audio

Audio system overview.....	252
Audio system controls.....	253
Radio functions.....	258
SiriusXM™ satellite radio.....	263
Auxiliary equipment.....	267
CD player/changer.....	270
Menu structure.....	273
Bluetooth® hands-free connection.....	274



11 Specifications

Label information.....	282
Dimensions	284
Weights	286
Fluids.....	288
Suspension.....	289
Engine oil.....	290
Engine specifications.....	291
Electrical system.....	292
Three-way catalytic converter.....	293
Overview of information and warning symbols	294
Volvo programs.....	296



12 Index

Index.....	298
------------	-----

12





Important information

Contacting Volvo

In the USA:

Volvo Cars of North America, LLC

Customer Care Center

1 Volvo Drive,

P.O. Box 914

Rockleigh, New Jersey 07647

1-800-458-1552

www.volvocars.com/us

In Canada:

Volvo Cars of Canada

National Customer Service

9130 Leslie Street, Suite 101

Richmond Hill, Ontario L4B 0B9

1-800-663-8255

www.volvocars.com/ca

About this manual

- Before you operate your vehicle for the first time, please familiarize yourself with the information found in the chapters "Instruments and controls" and "Starting and driving."
- Information contained in the balance of the manual is extremely useful and should be read after operating the vehicle for the first time.
- The manual is structured so that it can be used for reference. For this reason, it should be kept in the vehicle for ready access.

Footnotes

Certain pages of this manual contain information in the form of footnotes at the bottom of the page. This information supplements the text that the footnote number refers to (a letter is used if the footnote refers to text in a table).

Display texts

There are several displays in the driver's field of vision that show messages generated by various systems and functions in the vehicle. These texts are indicated in the Owner's Manual by being in slightly larger type than the surrounding text and are printed in gray, (for example: **Change doors unlock setting**).

Decals

There are various types of decals in the vehicle whose purpose is to provide important information in a clear and concise way. The importance of these decals is explained as follows, in descending order of importance.

Risk of injury

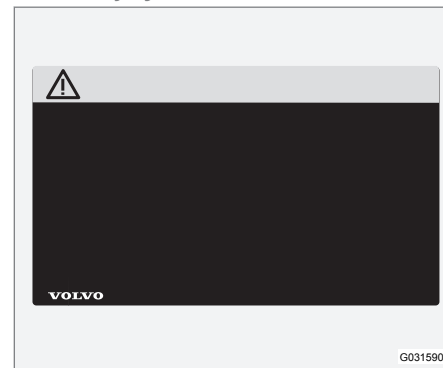

Black ISO symbols on a yellow warning background, white text/image on a black background. Decals of this type are used to indicate potential danger. Ignoring a warning of this type could result in serious injury or death.



Important information

Risk of damage to the vehicle



White ISO symbols and white text/image on a black or blue warning background and space for a message. If the information on decals of this type is ignored, damage to the vehicle could result.

Information

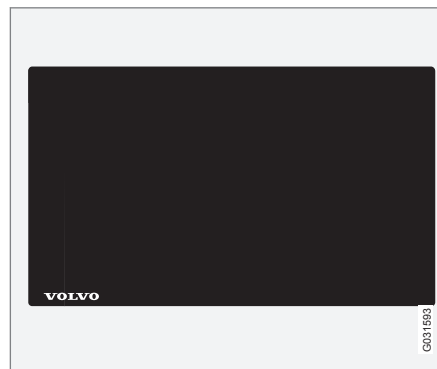

White ISO symbols and white text/image on a black background. These decals provide general information.

NOTE

The decals shown in the Owner's Manual are examples only and are not intended to be reproductions of the decals actually used in the vehicle. The purpose is to give an indication of how they look and their approximate location in the vehicle. The applicable information for your particular vehicle can be found on the respective decals in the vehicle.

Types of lists used in the manual

Procedures

Procedures (step-by-step instructions), or actions that must be carried out in a certain order, are arranged in numbered lists in this manual.

- 1** If there is a series of illustrations associated with step-by-step instructions, each step in the procedure is numbered in the same way as the corresponding illustration.
- A** Lists in which letters are used can be found with series of illustrations in cases where the order in which the instructions are carried out is not important.
- ➔** Arrows with or without numbers are used to indicate the direction of a movement.
- ⚠** Arrows containing letters are used to indicate movement.

If there are no illustrations associated with a step-by-step list, the steps in the procedure are indicated by ordinary numbers.

Position lists

- 1** Red circles containing a number are used in general overview illustrations in which certain components are pointed out. The corresponding number is also used in the position list's description of the various components.



Important information

Bullet lists

Bullets are used to differentiate a number of components/functions/points of information that can be listed in random order.

For example:

- Coolant
- Engine oil

Continued

▶▶ This symbol can be found at the lower right corner of an odd-numbered (right-hand) page to indicate that the current topic is continued on the following page.

Options and accessories

Optional or accessory equipment described in this manual is indicated by an asterisk.

Optional or accessory equipment may not be available in all countries or markets. Please note that some vehicles may be equipped differently, depending on special legal requirements.

Contact your Volvo retailer for additional information.



NOTE

- All information, illustrations and specifications contained in this manual are based on the latest product information available at the time of publication.
- Volvo reserves the right to make model changes at any time, or to change specifications or design without notice and without incurring obligation.
- Do not export your Volvo to another country before investigating that country's applicable safety and emission control requirements. In some cases it may be difficult or impossible to comply with these requirements. Modifications to the emission control system(s) may render your Volvo not certifiable for legal operation in the U.S., Canada and other countries.



WARNING

If your vehicle is involved in an accident, unseen damage may affect its drivability and safety.



WARNING

CALIFORNIA proposition 65

Engine exhaust, some of its constituents, and certain vehicle components contain or emit chemicals known to the state of California to cause cancer, and birth defects or other reproductive harm. In addition, certain fluids contained in vehicles and certain products of component wear contain or emit chemicals known to the State of California to cause cancer, and birth defects or other reproductive harm.



WARNING

Certain components of this vehicle such as air bag modules, seat belt pretensioners, adaptive steering columns, and button cell batteries may contain Perchlorate material. Special handling may apply for service or vehicle end of life disposal.

See www.dtsc.ca.gov/hazardouswaste/perchlorate.

**Important information****Shiftlock**

When your vehicle is parked, the gear selector is locked in the **P** (Park) position. To release the selector from this position, turn the ignition key to position II (or start the engine), depress the brake pedal, press the button on the front side of the gear selector and move the selector from **P** (Park).

Keylock

When you switch off the ignition, the gear selector must be in the **P** (Park) position before the key can be removed from the ignition switch.

Anti-lock Brake System (ABS)

The ABS system in your vehicle performs a self-diagnostic test when the vehicle first reaches the speed of approximately 12 mph (20 km/h). The brake pedal will pulsate several times and a sound may be audible from the ABS control module. This is normal.

Fuel filler door

Press the button on the light switch panel (see the illustration on page 67) when the vehicle is at a standstill to unlock the fuel filler door. Please note that the fuel filler door will remain unlocked until the vehicle begins to move forward. An audible click will be heard when the fuel filler door relocks.

Points to keep in mind

- Do not export your Volvo to another country before investigating that country's applicable safety and exhaust emission requirements. In some cases it may be difficult or impossible to comply with these requirements. Modifications to the emission control system(s) may render your Volvo not certifiable for legal operation in the U.S., Canada and other countries.
- All information, illustrations and specifications contained in this manual are based on the latest product information available at the time of publication. Please note that some vehicles may be equipped differently, depending on special legal requirements. Optional equipment described in this manual may not be available in all markets.
- Some of the illustrations shown are generic and may not depict the exact model for which this manual is intended.
- Volvo reserves the right to make model changes at any time, or to change specifications or design without notice and without incurring obligation.

Volvo Structural Parts Statement

Volvo has always been and continues to be a leader in automotive safety. Volvo engineers and manufactures vehicles designed to help protect vehicle occupants in the event of a collision.

Volvos are designed to absorb the impact of a collision. This energy absorption system including, but not limited to, structural components such as bumper reinforcement bars, bumper energy absorbers, frames, rails, fender aprons, A-pillars, B-pillars and body panels must work together to maintain cabin integrity and protect the vehicle occupants.

The supplemental restraint system including but not limited to air bags, side curtain air bags, and deployment sensors work together with the above components to provide proper timing for air bag deployment.

Due to the above, Volvo Cars of North America does not support the use of aftermarket, alternative or anything other than original Volvo parts for collision repair.

In addition Volvo does not support the use or re-use of structural components from an existing vehicle that has been previously damaged. Although these parts may appear equivalent, it is difficult to tell if the parts have been previously replaced with non-OE parts or if the part has been damaged as a result of



Important information

a prior collision. The quality of these used parts may also have been affected due to environmental exposure.

Information on the Internet

Additional information about your vehicle is available at www.volvocars.com.

In order to read a QR code, a QR reader is necessary, which is available as an app for a number of different cell phones and can be downloaded from the App Store or Google Play.



QR code

Open Source Software Notice

This product uses certain free / open source and other software originating from third parties, that is subject to the GNU General Public License version 2 and 3 (GPLv2/ GPLv3), GNU Lesser General Public License version 3 (LGPLv3), The FreeType Project License ("FreeType License") and other different and/or additional copyright licenses,

disclaimers and notices. The links how to access the exact terms of GPLv2, GPLv3, LGPLv3, and the other open source software licenses, disclaimers, acknowledgements and notices are provided to you below. Please refer to the exact terms of the relevant License, regarding your rights under said licenses. Volvo Car Corporation (VCC) offers to provide the source code of said free/open source software to you for a charge covering the cost of performing such distribution, such as the cost of media, shipping and handling, upon written request. Please contact your nearest Volvo retailer.

This offer is valid for a period of at least three (3) years from the date of the distribution of this product by VCC / or for as long as VCC offers spare parts or customer support.

Portions of this product uses software copyrighted © v2.4.3/2010 The FreeTypeProject (www.freetype.org). All rights reserved.

This product includes software under following licenses:

GPL v2 : <http://www.gnu.org/licenses/old-licenses/gpl-2.0.html>

- Linux kernel (merge between MontaVista 2.6.31 kernel and kernel from L2.6.31_MX51_ER_1007 BSP)
- uBoot (based on v2009.08)
- busybox (based on version 1.13.2.)

GCC runtime library exception: <http://www.gnu.org/licenses/gcc-exception.html>

- libgcc_s.so.1

LGPL v3: <http://www.gnu.org/licenses/lgpl.html>

- Libc.so.6, libpthread.so.0, Librt.so.1

The FreeType Project License: <http://www.freetype.org/FTL.TXT>

- libfreetype.so.6 (version 2.4.3)

Volvo and the environment

Volvo is committed to the well being of its customers. As a natural part of this commitment, we care about the environment in which we all live. Caring for the environment means an everyday involvement in reducing our environmental impact. Volvo's environmental activities are based on a holistic view, which means we consider the overall environmental impact of a product throughout its complete life cycle. In this context, design, production, product use, and recycling are all important considerations. In production, Volvo has partly or completely phased out several chemicals including CFCs, lead chromates, asbestos, and cadmium; and reduced the number of chemicals used in our plants 50% since 1991.

Volvo was the first in the world to introduce into production a three-way catalytic converter with a Lambda sond, now called the heated oxygen sensor, in 1976. The current version of this highly efficient system reduces emissions of harmful substances (CO, HC, NOx) from the exhaust pipe by approximately 95 – 99% and the search to eliminate the remaining emissions continues. Volvo is the only automobile manufacturer to offer CFC-free retrofit kits for the air conditioning system of all models as far back as the 1975 model 240. Advanced electronic engine con-

trols and cleaner fuels are bringing us closer to our goal. In addition to continuous environmental refinement of conventional gasoline-powered internal combustion engines, Volvo is actively looking at advanced technology alternative-fuel vehicles.

When you drive a Volvo, you become our partner in the work to lessen the car's impact on the environment. To reduce your vehicle's environmental impact, you can:

- Maintain proper air pressure in your tires. Tests have shown decreased fuel economy with improperly inflated tires.
- Follow the recommended maintenance schedule in your Warranty and Service Records Information booklet.
- Drive at a constant speed whenever possible.
- See a trained and qualified Volvo service technician as soon as possible for inspection if the check engine (malfunction indicator) light illuminates, or stays on after the vehicle has started.
- Properly dispose of any vehicle-related waste such as used motor oil, used batteries, brake pads, etc.
- When cleaning your vehicle, please use genuine Volvo car care products. All Volvo car care products are formulated to be environmentally friendly.

FSC®



The FSC® (Forest Stewardship Council®) symbol indicates that the wood pulp used in this publication comes from FSC® certified forests and other responsible sources.



Important warnings

Driver distraction

A driver has a responsibility to do everything possible to ensure his or her own safety and the safety of passengers in the vehicle and others sharing the roadway. Avoiding distractions is part of that responsibility.

Driver distraction results from driver activities that are not directly related to controlling the vehicle in the driving environment. Your new Volvo is, or can be, equipped with many feature-rich entertainment and communication systems. These include hands-free cellular telephones, navigation systems, and multi-purpose audio systems. You may also own other portable electronic devices for your own convenience. When used properly and safely, they enrich the driving experience. Improperly used, any of these could cause a distraction.

For all of these systems, we want to provide the following warning that reflects the strong Volvo concern for your safety. Never use these devices or any feature of your vehicle in a way that distracts you from the task of driving safely. Distraction can lead to a serious accident. In addition to this general warning, we offer the following guidance regarding specific newer features that may be found in your vehicle:

- Never use a hand-held cellular telephone while driving. Some jurisdictions prohibit

cellular telephone use by a driver while the vehicle is moving.

- If your vehicle is equipped with a navigation system, set and make changes to your travel itinerary only with the vehicle parked.
- Never program your audio system while the vehicle is moving. Program radio presets with the vehicle parked, and use your programmed presets to make radio use quicker and simpler.
- Never use portable computers or personal digital assistants while the vehicle is moving.

Accessory installation

- We strongly recommend that Volvo owners install only genuine, Volvo-approved accessories, and that accessory installations be performed only by a trained and qualified Volvo service technician.
- Genuine Volvo accessories are tested to ensure compatibility with the performance, safety, and emission systems in your vehicle. Additionally, a trained and qualified Volvo service technician knows where accessories may and may not be safely installed in your Volvo. In all cases, please consult a trained and qualified Volvo service technician before installing any accessory in or on your vehicle.

- Accessories that have not been approved by Volvo may or may not be specifically tested for compatibility with your vehicle. Additionally, an inexperienced installer may not be familiar with some of your car's systems.
- Any of your car's performance and safety systems could be adversely affected if you install accessories that Volvo has not tested, or if you allow accessories to be installed by someone unfamiliar with your vehicle.
- Damage caused by unapproved or improperly installed accessories may not be covered by your new vehicle warranty. See your Warranty and Service Records Information booklet for more warranty information. Volvo assumes no responsibility for death, injury, or expenses that may result from the installation of non-genuine accessories.



Occupant safety.....	18
Reporting safety defects.....	19
Seat belts.....	20
Supplemental Restraint System.....	23
Front airbags.....	24
Occupant Weight Sensor.....	28
Side impact protection airbags.....	32
Inflatable Curtain.....	34
Whiplash Protection System.....	36
Child safety.....	38
Child restraint systems.....	41
Infant seats.....	43
Convertible seats.....	45
Booster cushions.....	48
ISOFIX/LATCH lower anchors.....	49
Top tether anchors.....	51
Integrated booster cushion.....	52



01

SAFETY





Occupant safety

Volvo's concern for safety

Safety is the Volvo cornerstone. Our concern dates back to 1927 when the first Volvo rolled off the production line. Three-point seat belts (a Volvo invention), safety cages, and energy-absorbing impact zones were designed into Volvo vehicles long before it was fashionable or required by government regulation. We will not compromise our commitment to safety. We continue to seek out new safety features and to refine those already in our vehicles. You can help. We would appreciate hearing your suggestions about improving automobile safety. We also want to know if you ever have a safety concern with your vehicle. Call us in the U.S. at: 800-458-1552 or in Canada at: 800-663-8255.

Occupant safety reminders

How safely you drive doesn't depend on how old you are but rather on:

- How well you see.
- Your ability to concentrate.
- How quickly you make decisions under stress to avoid an accident.

The tips listed below are suggestions to help you cope with the ever changing traffic environment.

- Never drink and drive.
- If you are taking any medication, consult your physician about its potential effects on your driving abilities.
- Take a driver-retraining course.
- Have your eyes checked regularly.
- Keep your windshield and headlights clean.
- Replace wiper blades when they start to leave streaks.
- Take into account the traffic, road, and weather conditions, particularly with regard to stopping distance.
- Never send text messages while driving.
- Refrain from using or minimize the use of a cell phone while driving.

Recall information

Information regarding recalls or other service campaigns is available on our website at www.volvocars.com/us/. Select the tab YOUR VOLVO and the heading RECALL INFORMATION will be displayed at the lower left side of the screen. Enter your Vehicle Identification Number for your vehicle (found at the base of the windshield). If your vehicle has any open Recalls, they will be displayed on this page.

Volvo customers in Canada

For any questions regarding open recalls for your vehicle, please contact your authorized Volvo retailer. If your retailer is unable to answer your questions, please contact Volvo Customer Relations at 905 695-9626, Monday through Friday, 8:30 A.M. to 5:00 P.M. EST or by e-mail at vlcust@volvocars.com. You may also write us at:

Volvo Cars of Canada
National Customer Service
9130 Leslie Street, Suite 101
Richmond Hill, Ontario L4B 0B9

**Reporting safety defects****Reporting safety defects in the U.S.**

If you believe that your vehicle has a defect which could cause a crash or could cause injury or death, you should immediately inform the National Highway Traffic Safety Administration (NHTSA) in addition to notifying Volvo Cars of North America, LLC. If NHTSA receives similar complaints, it may open an investigation, and if it finds that a safety defect exists in a group of vehicles, it may order a recall and remedy campaign. However, NHTSA cannot become involved in individual problems between you, your retailer, or Volvo Cars of North America, LLC. To contact NHTSA, you may either call the Auto Safety Hotline toll-free at

1-888-327-4236

(TTY: 1-800-424-9153) or write to:
NHTSA, U.S. Department of Transportation, Washington D.C. 20590.

You can also obtain other information about motor vehicle safety from:

<http://www.safercar.gov>

Volvo strongly recommends that if your vehicle is covered under a service campaign, safety or emission recall or similar action, it should be completed as soon as possible. Please check with your local retailer or Volvo Cars of North America, LLC if your vehicle is covered under these conditions.

NHTSA can be reached at:

Internet:

<http://www.nhtsa.gov>

Telephone:

1-888-DASH-2-DOT
(1-888-327-4236).

Reporting safety defects in Canada

If you believe your vehicle has a defect that could cause a crash or could cause injury or death, you should immediately inform Transport Canada in addition to notifying Volvo Cars of Canada Corp.

Transport Canada can be contacted at:

1-800-333-0510

Teletypewriter (TTY): 613 990-4500

Fax: 1-819-994-3372

Mailing Address: Transport Canada - Road Safety, 80 rue Noël, Gatineau, (Quebec) J8Z 0A1



Seat belts

Using seat belts

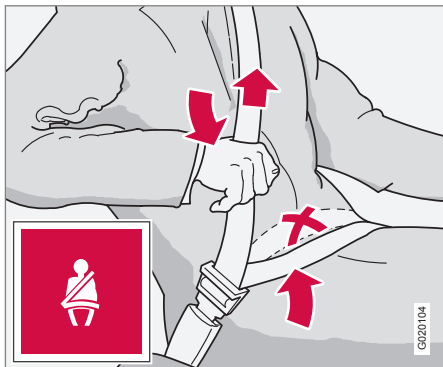

Adjusting the seat belt

Volvo, the inventor of the three-point seat belt, urges you and all occupants of your vehicle to wear seat belts and ensure that children are properly restrained, using an infant, car, or booster seat determined by age, weight and height.

Volvo also believes no child should sit in the front seat of a vehicle.

Most states and provinces make it mandatory for occupants of a vehicle to use seat belts.

Seat belt pretensioners

The seat belts are equipped with pretensioners that reduce slack in the belts. These pre-

tensioners are triggered in situations where the airbags deploy. The front seat belts also include a tension reducing device which, in the event of a collision, limits the peak forces exerted by the seat belt on the occupant.

Buckling a seat belt

Pull the belt out far enough to insert the latch plate into the receptacle until a distinct click is heard. The seat belt retractor is normally "unlocked" and you can move freely, provided that the shoulder belt is not pulled out too far.

The seat belt retractor will lock up in the following situations:

- if the belt is pulled out rapidly
- during braking and acceleration
- if the vehicle is leaning excessively
- when driving in turns
- if the Automatic Locking Retractor/Emergency Locking Retractor (ALR/ELR) is activated



NOTE

Each seat belt (except for the driver's belt) is equipped with the ALR/ELR function, which is designed to help keep the seat belt taut. ALR/ELR activates if the seat belt is pulled out as far as possible. If this is done, a sound from the seat belt retractor will be audible, which is normal, and the seat belt will be pulled taut and locked in place. This function is automatically disabled when the seat belt is unbuckled and fully retracted.

See also page 39 for information about using a seat belt's ALR/ELR function to anchor a child seat.

When wearing the seat belt remember:

- The belt should not be twisted or turned.
- The lap section of the belt must be positioned low on the hips (not pressing against the abdomen).
- Make sure that the shoulder belt is rolled up into its retractor and that the shoulder and lap belts are taut.

Unbuckling the seat belt

To remove the seat belt, press the red section on the seat belt receptacle. Before exiting the vehicle, check that the seat belt retracts fully after being unbuckled. If necessary, guide the belt back into the retractor slot.



Seat belt reminder

The seat belt reminder consists of an audible signal, an indicator light above the rearview mirror, and a symbol in the instrument panel that alert the driver and front seat passenger if their seat belts are not fastened.

WARNING

- Never use a seat belt for more than one occupant.
- Never wear the shoulder portion of the belt under the arm, behind the back or otherwise out of position. Such use could cause injury in the event of an accident.
- Seat belts lose much of their strength when exposed to violent stretching and should be replaced after any collision, even if they appear to be undamaged.
- Never repair the belt yourself; have this work done by an authorized Volvo service technician only.
- Any device used to induce slack into the shoulder belt portion of the three-point belt system will have a detrimental effect on the amount of protection available to you in the event of a collision.
- The seat back should not be tilted too far back. The shoulder belt must be taut in order to function properly.
- Do not use child safety seats or child booster cushions/backrests in the front passenger's seat. We also recommend that children who have outgrown these devices sit in the rear

seat with the seat belt properly fastened.

Seat belt use during pregnancy



The seat belt should always be worn during pregnancy. But it is crucial that it be worn in the correct way. The diagonal section should wrap over the shoulder then be routed between the breasts and to the side of the belly. The lap section should lay flat over the thighs and as low as possible under the belly. It must never be allowed to ride upward. Remove all slack from the belt and insure that it fits close to the body without any twists.



Seat belts

As a pregnancy progresses, pregnant drivers should adjust their seats and steering wheel such that they can easily maintain control of the vehicle as they drive (which means they must be able to easily operate the foot pedals and steering wheel). Within this context, they should strive to position the seat with as large a distance as possible between their belly and the steering wheel.

Child seats

Please see page 39 for information on securing child seats with the seat belts.

Seat belt maintenance

Check periodically that the seat belts are in good condition. Use water and a mild detergent for cleaning. Check seat belt mechanism function as follows: attach the seat belt and pull rapidly on the strap.



Supplemental Restraint System

Supplemental Restraint System (SRS)

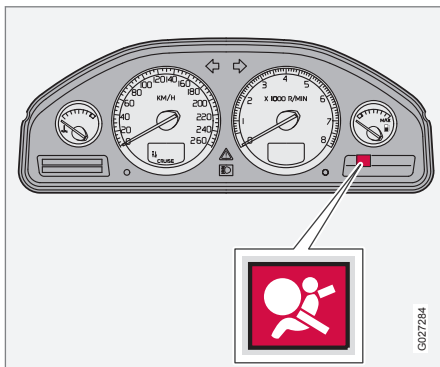

SRS warning light

As an enhancement to the three-point seat belts, your Volvo is equipped with a Supplemental Restraint System (SRS). Volvo's SRS consists of seat belt pretensioners, front airbags, side impact airbags, the occupant weight sensor, and inflatable curtains. All of these systems are monitored by the SRS control module. An SRS warning light in the instrument panel (see the illustration) illuminates when the ignition key is turned to position **I**, **II**, or **III**, and will normally go out after approximately 7 seconds if no faults are detected in the system.



Where applicable, a text message will also be displayed when the SRS warning light illuminates. If this warning symbol is not functioning properly, the general warning symbol illuminates and a text message will be displayed.

WARNING

- If the SRS warning light stays on after the engine has started or if it illuminates while you are driving, have the vehicle inspected by a trained and qualified Volvo service technician as soon as possible.
- Never try to repair any component or part of the SRS yourself. Any interference in the system could cause malfunction and serious injury. All work on these systems should be performed by an authorized Volvo service technician.

WARNING

If your vehicle has been subjected to flood conditions (e.g. soaked carpeting/standing water on the floor of the vehicle) or if your vehicle has become flood-damaged in any way, do not attempt to start the vehicle or put the key in the ignition before disconnecting the battery (see below). This may cause airbag deployment which could result in personal injury. Have the vehicle towed to a trained and qualified Volvo service technician for repairs.

Automatic transmission:

Before attempting to tow the vehicle, use the following procedure to override the shiftlock system to move the gear selector to the neutral position:

1. Switch off the ignition for at least 10 minutes and disconnect the battery.
2. Wait at least one minute.
3. Insert the key in the ignition and turn it to position **II**
4. Press firmly on the brake pedal.
5. Move the gear selector from **P** (Park) to the **N** (Neutral) position.



Front airbags

The front airbag system

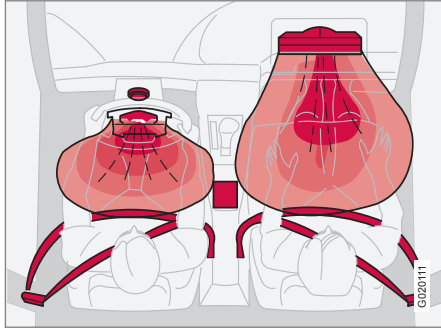

The front airbags supplement the three-point seat belts. For these airbags to provide the protection intended, seat belts must be worn at all times.

The front airbag system includes gas generators surrounded by the airbags, and deceleration sensors that activate the gas generators, causing the airbags to be inflated with nitrogen gas.

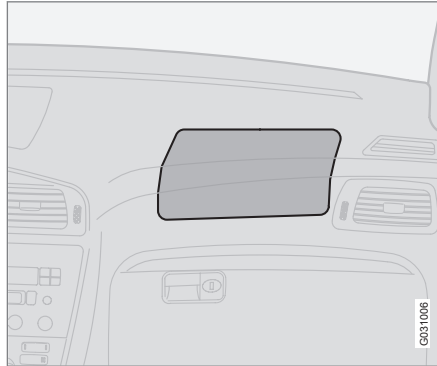

Location of the passenger's side front airbag

As the movement of the seats' occupants compresses the airbags, some of the gas is expelled at a controlled rate to provide better cushioning. Both seat belt pretensioners also deploy, minimizing seat belt slack. The entire process, including inflation and deflation of the airbags, takes approximately one fifth of a second.

The location of the front airbags is indicated by **SRS AIRBAG** embossed on the steering wheel pad and above the glove compartment, and by decals on both sun visors and on the front and far right side of the dash.

- The driver's side front airbag is folded and located in the steering wheel hub.
- The passenger's side front airbag is folded behind a panel located above the glove compartment.

WARNING

- The airbags in the vehicle are designed to be a **SUPPLEMENT** to—not a replacement for—the three-point seat belts. For maximum protection, wear seat belts at all times. Be aware that no system can prevent all possible injuries that may occur in an accident.
- Never drive a vehicle with your hands on the steering wheel pad/airbag housing.
- The front airbags are designed to help prevent serious injury. Deployment occurs very quickly and with considerable force. During normal deployment and depending on variables such as seating position, one may experience abrasions, bruises, swellings, or other injuries as a result from deployment of one or both of the airbags.
- When installing any accessory equipment, make sure that the front airbag system is not damaged. Any interference in the system could cause malfunction.

**Front airbags****Front airbag deployment**

- The front airbags are designed to deploy during certain frontal or front-angular collisions, impacts, or decelerations, depending on the crash severity, angle, speed and object impacted. The airbags may also deploy in certain non-frontal collisions where rapid deceleration occurs.
- The SRS sensors, which trigger the front airbags, are designed to react to both the impact of the collision and the inertial forces generated by it, and to determine if the intensity of the collision is sufficient for the seat belt pretensioners and/or airbags to be deployed.

However, not all frontal collisions activate the front airbags.

- If the collision involves a nonrigid object (e.g., a snow drift or bush), or a rigid, fixed object at a low speed, the front airbags will not necessarily deploy.
- Front airbags do not normally deploy in a side impact collision, in a collision from the rear or in a rollover situation.
- The amount of damage to the bodywork does not reliably indicate if the airbags should have deployed or not.

 NOTE

- Deployment of front airbags occurs only one time during an accident. In a collision where deployment occurs, the airbags and seat belt pretensioners activate. Some noise occurs and a small amount of powder is released. The release of the powder may appear as smoke-like matter. This is a normal characteristic and does not indicate fire.
- Volvo's front airbags use special sensors that are integrated with the front seat buckles. The point at which the airbag deploys is determined by whether or not the seat belt is being used, as well as the severity of the collision.
- Collisions can occur where only one of the airbags deploys. If the impact is less severe, but severe enough to present a clear injury risk, the airbags are triggered at partial capacity. If the impact is more severe, the airbags are triggered at full capacity.

Should you have questions about any component in the SRS system, please contact a trained and qualified Volvo service technician or Volvo customer support:

In the USA

Volvo Cars of North America, LLC
 Customer Care Center
 1 Volvo Drive
 P.O. Box 914
 Rockleigh, New Jersey 07647
 1-800-458-1552
www.volvocars.us

In Canada

Volvo Cars of Canada Corp.
 National Customer Service
 9130 Leslie Street, Suite 101
 Richmond Hill, Ontario L4B 0B9
 1-800-663-8255
www.volvocars.ca



Front airbags

WARNING

- Do not use child safety seats or child booster cushions/backrests in the front passenger's seat. We also recommend that occupants under 4 feet 7 inches (140 cm) in height who have outgrown these devices sit in the rear seat with the seat belt fastened.
- Never drive with the airbags deployed. The fact that they hang out can impair the steering of your vehicle. Other safety systems can also be damaged.
- The smoke and dust formed when the airbags are deployed can cause skin and eye irritation in the event of prolonged exposure.



Airbag decal on the outside of both sun visors

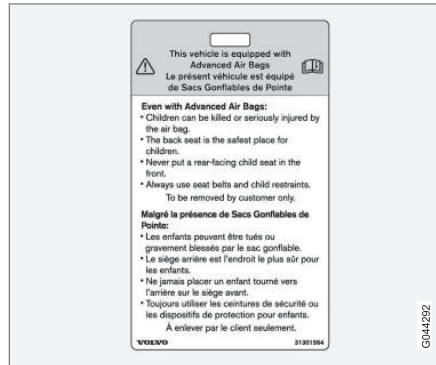

Passenger's side airbag decal

WARNING

- Children must never be allowed in the front passenger's seat.
- Occupants in the front passenger's seat must never sit on the edge of the seat, sit leaning toward the instrument panel or otherwise sit out of position.
- The occupant's back must be as upright as comfort allows and be against the seat back with the seat belt properly fastened.
- Feet must be on the floor, e.g., not on the dash, seat or out of the window.

**! WARNING**

- No objects or accessory equipment, e.g. dashboard covers, may be placed on, attached to, or installed near the air bag hatch (the area above the glove compartment) or the area affected by airbag deployment.
- There should be no loose articles, e.g. coffee cups, on the floor, seat, or dashboard area.
- Never try to open the airbag cover on the steering wheel or the passenger's side dashboard. This should only be done by a trained and qualified Volvo service technician.

Failure to follow these instructions can result in injury to the vehicle occupants.



Occupant Weight Sensor

Disabling the passenger's side front airbag

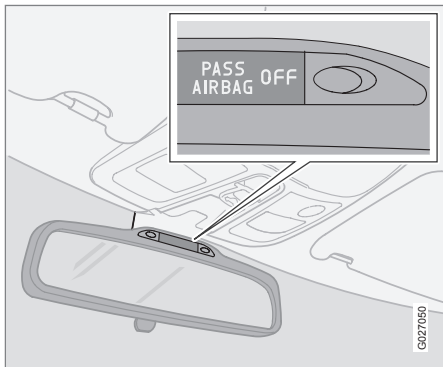

Occupant Weight Sensor (OWS) indicator light

Volvo recommends that ALL occupants (adults and children) shorter than 4 feet 7 inches (140 cm) be seated in the rear seat of any vehicle with a passenger's side front airbag, and be properly restrained. Children should always be seated in child restraints appropriate for their size and weight. For child safety recommendations, see page 38.

The Occupant Weight Sensor (OWS) is designed to meet the regulatory requirements of Federal Motor Vehicle Safety Standard (FMVSS) 208 and is designed to disable (will

not inflate) the passenger's side front airbag under certain conditions.

The OWS works with sensors that are part of the front passenger's seat and seat belt. The sensors are designed to detect the presence of a properly seated occupant and determine if the passenger's side front airbag should be enabled (may inflate) or disabled (will not inflate).

The OWS will disable (will not inflate) the passenger's side front airbag when:

- the front passenger's seat is unoccupied, or has small/medium objects in the front seat,
- the system determines that an infant is present in a rear-facing infant seat that is installed according to the manufacturer's instructions,
- the system determines that a small child is present in a forward-facing child restraint that is installed according to the manufacturer's instructions,
- the system determines that a small child is present in a booster seat,
- a front passenger takes his/her weight off of the seat for a period of time,
- a child or a small person occupies the front passenger's seat.

The OWS uses a **PASSENGER AIRBAG OFF** indicator lamp which will illuminate and stay on to remind you that the passenger's side front airbag is disabled. The **PASSENGER AIRBAG OFF** indicator lamp is located in the overhead console, near the base of the rear-view mirror.

i NOTE

The **PASSENGER AIRBAG OFF** indicator lamp will illuminate for a short period of time when the ignition is turned on to confirm it is functional. When the front passenger's seat is not occupied (empty seat) or in the event that the passenger's side front airbag is enabled (may inflate), the **PASSENGER AIRBAG OFF** indicator lamp will be off.

However, if a fault is detected in the system:

- The OWS indicator light will stay on
- The SRS warning light (see page 23) will come on and stay on
- The message **PASS. AIRBAG OFF SERVICE URGENT** will be displayed in the information display.



Occupant Weight Sensor

WARNING



- If a fault in the system is detected and indicated as explained, be aware that the passenger's side front airbag will not deploy in the event of a collision.
- In this case, the safety systems and Occupant Weight Sensor should be inspected by a trained and qualified Volvo service technician as soon as possible.

WARNING

- Never try to open, remove, or repair any components in the OWS system. This could result in system malfunction. Maintenance or repairs should only be carried out by a trained and qualified Volvo service technician.
- The front passenger's seat should not be modified in any way. This could reduce pressure on the seat cushion, which might interfere with the OWS system's function.

The OWS is designed to disable (will not inflate) the passenger's side front airbag when a rear facing infant seat, a forward-facing child restraint, or a booster seat is detected. The **PASSENGER AIRBAG OFF**

indicator lamp will illuminate and stay on to remind you that the passenger's side front airbag is disabled (see the following table).

Passenger's seat occupancy status	OWS indicator light status	Passenger's side front airbag status
Seat unoccupied	OWS indicator light  is not lit	Passenger's side front airbag disabled
Seat occupied by low weight occupant/object ^A	OWS indicator light  lights up	Passenger's side front airbag disabled
Seat occupied by heavy occupant/object	OWS indicator light  is not lit	Passenger's side front airbag enabled

^A Volvo recommends that children always be properly restrained in appropriate child restraints in the rear seats. In rare situations when the seat belt is not properly fastened, some child restraints may not be detected by the OWS because there is very little weight on the vehicle seat cushion. In these cases the passenger's side front airbag may be disabled, but the **PASSENGER AIRBAG OFF** indicator lamp will not be lit. Do not assume that the passenger's side front airbag is disabled unless the **PASSENGER**

AIRBAG OFF indicator lamp is lit. Make sure the child restraint is properly installed (turn the vehicle off, remove the child restraint from the vehicle and reinstall the restraint following the child restraint manufacturer's instructions) and that the **PASSENGER AIRBAG OFF** indicator lamp is on, or move the child restraint to the rear seat.

The OWS is designed to enable (may inflate) the passenger's side front airbag in the event of a collision anytime the system senses that a person of adult size is sitting properly in the front passenger's seat. The **PASSENGER AIRBAG OFF** indicator lamp will be off and remain off.

If a person of adult size is sitting in the front passenger's seat, but the **PASSENGER AIRBAG OFF** indicator lamp is on, it is possible that the person isn't sitting properly in the seat. If this happens:

1. Turn the vehicle off and ask the person to place the seat back in an upright position.
2. Have the person sit upright in the seat, centered on the seat cushion, with the person's legs comfortably extended.
3. Restart the vehicle and have the person remain in this position for about two minutes. This will allow the system to detect that person and enable the passenger's frontal airbag.
4. If the **PASSENGER AIRBAG OFF** indicator lamp remains on even after this, the



Occupant Weight Sensor

person should be advised to ride in the rear seat.

This condition reflects limitations of the OWS classification capability. It does not indicate OWS malfunction.

Modifications

If you are considering modifying your vehicle in any way to accommodate a disability, for example by altering or adapting the driver's or front passenger's seat(s) and/or airbag systems, please contact Volvo at:

In the USA

Volvo Cars of North America, LLC
Customer Care Center
1 Volvo Drive
P.O. Box 914 Rockleigh,
New Jersey 07647
1-800-458-1552

In Canada

Volvo Cars of Canada Corp.
National Customer Service
9130 Leslie Street, Suite 101
Richmond Hill, Ontario L4B 0B9
1-800-663-8255



WARNING

- No objects that add to the total weight on the seat should be placed on the front passenger's seat. If a child is seated in the front passenger's seat with any additional weight, this extra weight could cause the OWS system to enable the airbag, which might cause it to deploy in the event of a collision, thereby injuring the child.
- The seat belt should never be wrapped around an object on the front passenger's seat. This could interfere with the OWS system's function.
- The front passenger's seat belt should never be used in a way that exerts more pressure on the passenger than normal. This could increase the pressure exerted on the weight sensor by a child, and could result in the airbag being enabled, which might cause it to deploy in the event of a collision, thereby injuring the child.



WARNING

Keep the following points in mind with respect to the OWS system. Failure to follow these instructions could adversely affect the system's function and result in serious injury to the occupant of the front passenger's seat:

- The full weight of the front seat passenger should always be on the seat cushion. The passenger should never lift him/herself off the seat cushion using the armrest in the door or the center console, by pressing the feet on the floor, by sitting on the edge of the seat cushion, or by pressing against the backrest in a way that reduces pressure on the seat cushion. This could cause OWS to disable the front passenger's side airbag.
- Do not place any type of object on the front passenger's seat in such a way that jamming, pressing, or squeezing occurs between the object and the front seat, other than as a direct result of the correct use of the Automatic Locking Retractor/Emergency Locking Retractor (ALR/ELR) seat belt (see page 39).
- No objects should be placed under the front passenger's seat. This could

**Occupant Weight Sensor**

01

interfere with the OWS system's function.



Side impact protection airbags

Side impact airbags – front seats only

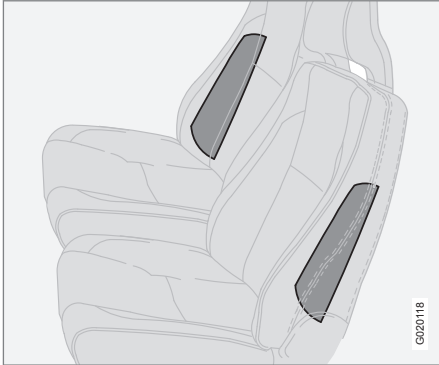

Location of the side impact (SIPS) airbag

As an enhancement to the structural side impact protection built into your vehicle, the vehicle is also equipped with Side Impact Protection System (SIPS) airbags.

The SIPS airbag system is designed to help increase occupant protection in the event of certain side impact collisions. The SIPS airbags are designed to deploy only during certain side-impact collisions, depending on the crash severity, angle, speed and point of impact.

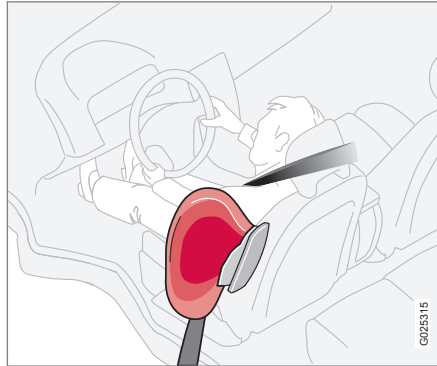

Driver's side SIPS airbag

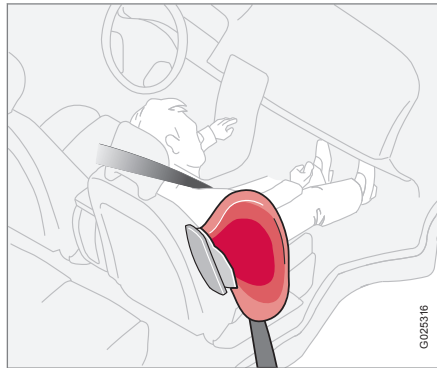

Passenger's side SIPS airbag



NOTE

SIPS airbag deployment (one airbag) occurs only on the side of the vehicle affected by the impact. The airbags are not designed to deploy in all side impact situations.

Components in the SIPS airbag system

This SIPS airbag system consists of gas generators and side airbag modules built into the outboard sides of both front seat backrests.



Side impact protection airbags

01

⚠ WARNING

- The SIPS airbag system is a supplement to the structural Side Impact Protection System and the three-point seat belt system. It is not designed to deploy during collisions from the front or rear of the vehicle or in rollover situations.
- The use of seat covers on the front seats may impede SIPS airbag deployment.
- No objects, accessory equipment or stickers may be placed on, attached to or installed near the SIPS airbag system or in the area affected by SIPS airbag deployment.
- Never try to open or repair any components of the SIPS airbag system. This should be done only by a trained and qualified Volvo service technician.
- In order for the SIPS airbag to provide its best protection, both front seat occupants should sit in an upright position with the seat belt properly fastened.
- Failure to follow these instructions can result in injury to the occupants of the vehicle in the event of an accident.



Inflatable Curtain

The Inflatable Curtain (IC)

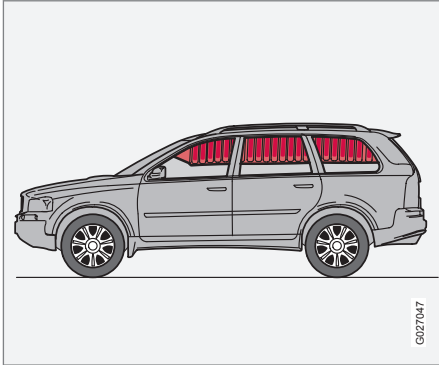

This system consists of inflatable curtains located along the sides of the roof liners, stretching from the front side windows to the rear edge of the rear side windows. It is designed to help protect the heads of the occupants of the front seats and the occupants of the outboard rear seating positions, including the outboard passenger in the third row of seats in certain side impact collisions.

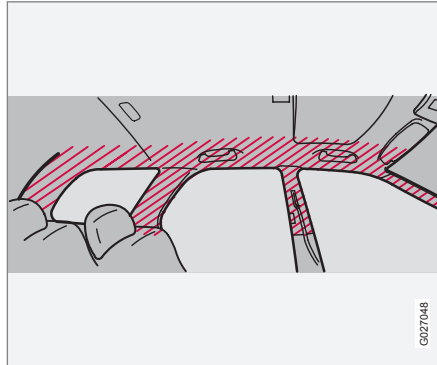

The inflatable curtains in the Volvo XC90 are also designed to help protect the occupants of the vehicle in a roll-over situation, and to help prevent them from being thrown from the vehicle if a roll-over occurs.

i NOTE

The Inflatable Curtains extend to protect all three rows of seats.

By design, the IC system deploys only on the side of the vehicle affected by the impact.

However, in certain side impacts, or in a roll-over situation, **BOTH** the Inflatable Curtains and the Side Impact Airbag System (SIPS-

bag) will deploy, whereas, in some cases, **ONLY** the Inflatable Curtain will deploy. In cases where **BOTH** the Inflatable Curtain and the SIPS-bag deploy, deployment will occur simultaneously.

i NOTE

If the Inflatable Curtain deploys, it remains inflated for approximately 5 seconds.

! WARNING

- The IC system is a supplement to the Side Impact Protection System. It is not designed to deploy during collisions from the front or the rear of the vehicle.
- Never try to open or repair any components of the IC system. This should be done only by a trained and qualified Volvo service technician.
- Never hang heavy items from the ceiling handles. This could impede deployment of the Inflatable curtain.



Inflatable Curtain

01

 **WARNING**

In order for the IC to provide its best protection, both front seat occupants and both outboard rear seat occupants should sit in an upright position with the seat belt properly fastened; adults using the seat belt and children using the proper child restraint system. Only adults should sit in the front seats. Children must never be allowed in the front passenger seat. See page 39 for guidelines. Failure to follow these instructions can result in injury to the vehicle occupants in an accident.



Whiplash Protection System

Whiplash Protection System (WHIPS) – front seats only

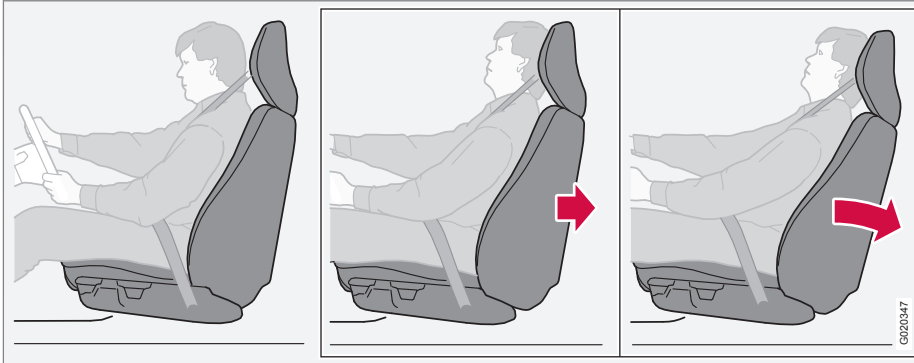

The Whiplash Protection System (WHIPS) consists of specially designed hinges and brackets on the front seat backrests designed to help absorb some of the energy generated in a collision from the rear (when the vehicle is "rear-ended").

In the event of a collision of this type, the hinges and brackets of the front seat backrests are designed to change position slightly to allow the backrest/head restraint to help support the occupant's head before moving slightly rearward. This movement helps absorb some of the forces that could result in whiplash.

WARNING

- The WHIPS system is designed to supplement the other safety systems in your vehicle. For this system to function properly, the three-point seat belt must be worn. Please be aware that no system can prevent all possible injuries that may occur in an accident.
- The WHIPS system is designed to function in certain collisions from the rear, depending on the crash severity, angle and speed.

WARNING

Occupants in the front seats must never sit out of position. The occupant's back must be as upright as comfort allows and be against the seat back with the seat belt properly fastened.



Whiplash Protection System

! WARNING

- If your vehicle has been involved in a rear-end collision, the front seat backrests must be inspected by a trained and qualified Volvo service technician, even if the seats appear to be undamaged. Certain components in the WHIPS system may need to be replaced.
- Do not attempt to service any component in the WHIPS system yourself.

! WARNING

Any contact between the front seat backrests and the folded rear seat could impede the function of the WHIPS system. If the rear seat is folded down, the occupied front seats must be adjusted forward so that they do not touch the folded rear seat.

! WARNING

- Boxes, suitcases, etc. wedged behind the front seats could impede the function of the WHIPS system.
- If the rear seat backrests are folded down, cargo must be secured to prevent it from sliding forward against the front seat backrests in the event of a collision from the rear. This could interfere with the action of the WHIPS system.



Child safety

Children should be seated safely

Volvo recommends the proper use of restraint systems for all occupants including children. Remember that, regardless of age and size, a child should always be properly restrained in a vehicle.

Your vehicle is also equipped with ISOFIX/LATCH attachments, which make it more convenient to install child seats.

Some restraint systems for children are designed to be secured in the vehicle by lap belts or the lap portion of a lap-shoulder belt. Such child restraint systems can help protect children in vehicles in the event of an accident only if they are used properly. However, children could be endangered in a crash if the child restraints are not properly secured in the vehicle. Failure to follow the installation instructions for your child restraint can result in your child striking the vehicle's interior in a sudden stop.

Holding a child in your arms is NOT a suitable substitute for a child restraint system. In an accident, a child held in a person's arms can be crushed between the vehicle's interior and an unrestrained person. The child could also be injured by striking the interior, or by being ejected from the vehicle during a sudden maneuver or impact. The same can also happen if the infant or child rides unrestrained on

the seat. Other occupants should also be properly restrained to help reduce the chance of injuring or increasing the injury of a child.

All states and provinces have legislation governing how and where children should be carried in a vehicle. Find out the regulations existing in your state or province. Recent accident statistics have shown that children are safer in rear seating positions than front seating positions when properly restrained. A child restraint system can help protect a child in a vehicle. Here's what to look for when selecting a child restraint system:

- It should have a label certifying that it meets applicable Federal Motor Vehicle Safety Standards (FMVSS 213) – or in Canada, CMVSS 213.
- Make sure the child restraint system is approved for the child's height, weight and development – the label required by the standard or regulation, or instructions for infant restraints, typically provide this information.
- In using any child restraint system, we urge you to carefully look over the instructions that are provided with the restraint. Be sure you understand them and can use the device properly and safely in this vehicle. A misused child restraint system can result in increased

injuries for both the infant or child and other occupants in the vehicle.

When a child has outgrown the child safety seat, you should use the rear seat with the standard seat belt fastened. The best way to help protect the child here is to place the child on a cushion so that the seat belt is properly located on the hips, see page 48. Legislation in your state or province may mandate the use of a child seat or cushion in combination with the seat belt, depending on the child's age and/or size. Please check local regulations.

A specially designed and tested booster cushion and backrest can be obtained from your Volvo retailer.

USA: for children weighing 33 – 80 lbs. (15 – 36 kg) and 38 – 54 inches (97 – 137 cm) in height

Canada: for children weighing 40 – 80 lbs. (18 – 36 kg) and 40 – 54 inches (102 – 137 cm) in height

**WARNING**

- Do not use child safety seats or child booster cushions/backrests in the front passenger's seat. We also recommend that children under 4 feet 7 inches (140 cm) in height who have outgrown these devices sit in the rear seat with the seat belt fastened.
- On hot days, the temperature in the vehicle interior can rise very quickly. Exposure to these high temperatures for even a short period of time can cause heat-related injury or death. Small children are particularly at risk.

Child seat should always be registered. See page 40 for more information.

**Automatic Locking Retractor/
Emergency Locking Retractor (ALR/
ELR)**

To make child seat installation easier, each seat belt (except for the driver's belt) is equipped with a locking mechanism to help keep the seat belt taut.

When attaching the seat belt to a child seat:

1. Attach the seat belt to the child seat according to the child seat manufacturer's instructions.
2. Pull the seat belt out as far as possible.
3. Insert the seat belt latch plate into the buckle (lock) in the usual way.
4. Release the seat belt and pull it taut around the child seat.

A sound from the seat belt retractor will be audible at this time and is normal. The belt will now be locked in place. This function is automatically disabled when the seat belt is unlocked and the belt is fully retracted.

WARNING

Do not use child safety seats or child booster cushions/backrests in the front passenger's seat. We also recommend that children who have outgrown these devices sit in the rear seat with the seat belt properly fastened.

Volvo's recommendations

Why does Volvo believe that no child should sit in the front seat of a car? It's quite simple really. A front airbag is a very powerful device designed, by law, to help protect an adult.

Because of the size of the airbag and its speed of inflation, a child should never be placed in the front seat, even if he or she is properly belted or strapped into a child safety seat. Volvo has been an innovator in safety for over seventy-five years, and we'll continue to do our part. But we need your help. Please remember to put your children in the back seat, and buckle them up.

Volvo has some very specific recommendations:

- Always wear your seat belt.
- Airbags are a SUPPLEMENTAL safety device which, when used with a three-point seat belt can help reduce serious injuries during certain types of accidents. Volvo recommends that you do not disconnect the airbag system in your vehicle.
- Volvo strongly recommends that everyone in the vehicle be properly restrained.
- Volvo recommends that ALL occupants (adults and children) shorter than 4 feet 7 inches (140 cm) be seated in the back



Child safety

seat of any vehicle with a front passenger side airbag.

- Drive safely!

Child restraint registration and recalls

Registering a child restraint

Child restraints could be recalled for safety reasons. You must register your child restraint to be reached in a recall. To stay informed about child safety seat recalls, be sure to fill out and return the registration card that comes with new child restraints.

Child restraint recall information is readily available in both the U.S. and Canada. For recall information in the U.S., call the U.S. Government's Auto Safety Hotline at 1-800-424-9393 or go to <http://www-odi.nhtsa.dot.gov/cars/problems/recalls/register/childseat/index.cfm>. In Canada, visit Transport Canada's Child Safety website at <http://www.tc.gc.ca/roadsafety/childsafety/menu.htm>.



Child restraint systems

Child restraints



Infant seat

There are three main types of child restraint systems: infant seats, convertible seats, and booster cushions. They are classified according to the child's age and size.

The following section provides **general information** on securing a child restraint using a three-point seat belt. Refer to page 49 and page 51 for information on securing a child restraint using ISOFIX/LATCH lower anchors and/or top tether anchorages.

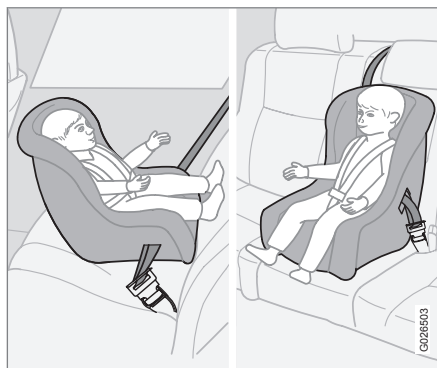

Convertible seat

WARNING

A child seat should never be used in the front passenger seat of any vehicle with a front passenger airbag – not even if the **PASSENGER AIRBAG OFF** symbol near the rear-view mirror is illuminated (on vehicles equipped with Occupant Weight Sensor). If the severity of an accident were to cause the airbag to inflate, this could lead to serious injury or death to a child seated in this position.



Booster cushion

WARNING

Always refer to the child restraint manufacturer's instructions for detailed information on securing the restraint.



Child restraint systems

WARNING

- When not in use, keep the child restraint system secured or remove it from the passenger compartment to help prevent it from injuring passengers in the event of a sudden stop or collision.
- A small child's head represents a considerable part of its total weight and its neck is still very weak. Volvo recommends that children up to age 4 travel, properly restrained, facing rearward. In addition, Volvo recommends that children should ride rearward facing, properly restrained, as long as possible.



Infant seats

01

Securing an infant seat with a seat belt

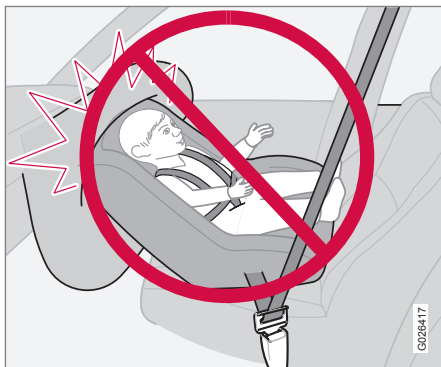

Do not place the infant seat in the front passenger's seat

NOTE

Refer to page 49 and page 51 for information on securing a child restraint using ISOFIX/LATCH lower anchors and/or top tether anchorages.

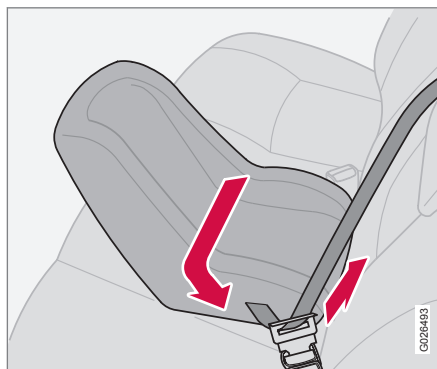

Positioning the seat belt through the infant seat

WARNING

- An infant seat must be in the rear-facing position only.
- The infant seat should not be positioned behind the driver's seat unless there is adequate space for safe installation.

1. Place the infant seat in the rear seat of the vehicle.
2. Attach the seat belt to the infant seat according to the manufacturer's instructions.

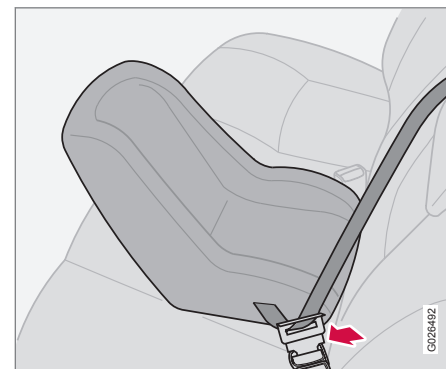

Fasten the seat belt

WARNING

A child seat should never be used in the front passenger seat of any vehicle with a front passenger airbag – not even if the "Passenger airbag off" symbol near the rear-view mirror is illuminated (on vehicles equipped with Occupant Weight Sensor). If the severity of an accident were to cause the airbag to inflate, this could lead to serious injury or death to a child seated in this position.



Infant seats

3. Fasten the seat belt by inserting the latch plate into the buckle (lock) until a distinct click is audible.

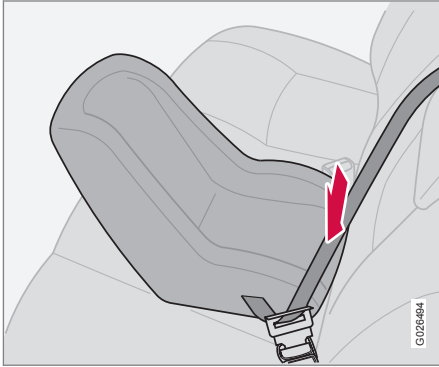

Pull out the shoulder section of the seat belt

4. Pull the shoulder section of the seat belt out as far as possible to activate the belt's automatic locking function.

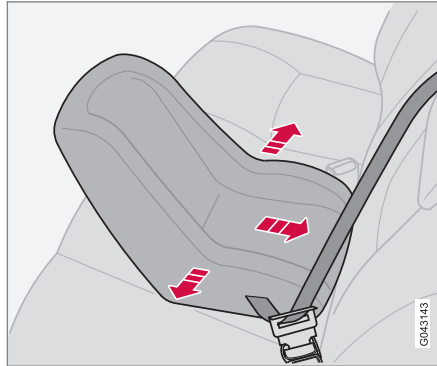

Ensure that the seat is securely in place

NOTE

The locking retractor will automatically release when the seat belt is unbuckled and allowed to retract fully.

5. Press the infant seat firmly in place, let the seat belt retract and pull it taut. A sound from the seat belt retractor's automatic locking function will be audible at this time and is normal. The seat belt should now be locked in place.
6. Push and pull the infant seat along the seat belt path to ensure that it is held securely in place by the seat belt.

 **WARNING**

It should not be possible to move the child restraint (child seat) more than 1 in. (2.5 cm) in any direction along the seat belt path.

The infant seat can be removed by unbuckling the seat belt and letting it retract completely.



Convertible seats

Securing a convertible seat with a seat belt

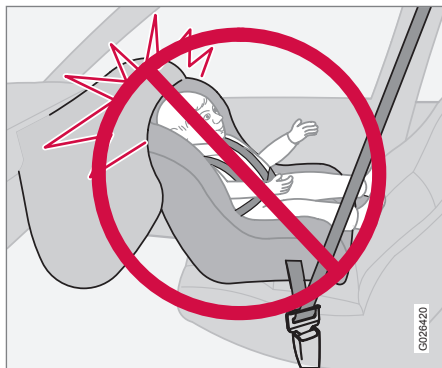

Do not place the convertible seat in the front passenger's seat

i NOTE

Refer to page 49 and page 51 for information on securing a child restraint using ISOFIX/LATCH lower anchors and/or top tether anchorages.

Convertible seats can be used in either a forward or rearward-facing position, depending on the age and size of the child.

! WARNING

Always use a convertible seat that is suitable for the child's age and size. See the convertible seat manufacturer's recommendations.

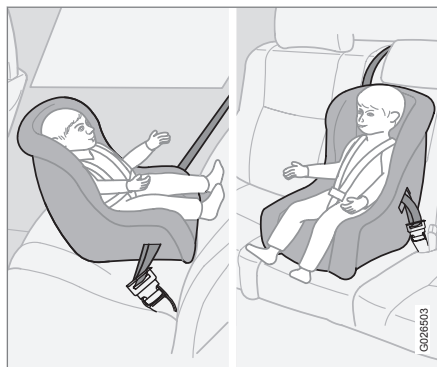

Route the seat belt through the convertible seat

! WARNING

A small child's head represents a considerable part of its total weight and its neck is still very weak. Volvo recommends that children up to age 4 travel, properly restrained, facing rearward. In addition, Volvo recommends that children should ride rearward facing, properly restrained, as long as possible.

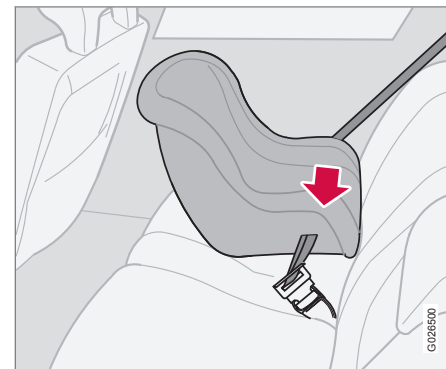

Fasten the seat belt



Convertible seats

WARNING

- Convertible child seats should be installed in the rear seat only.
- A rear-facing convertible seat should not be positioned behind the driver's seat unless there is adequate space for safe installation.

1. Place the convertible seat in the rear seat of the vehicle.
2. Attach the seat belt to the convertible seat according to the manufacturer's instructions.
3. Fasten the seat belt by inserting the latch plate into the buckle (lock) until a distinct click is audible.
4. Pull the shoulder section of the seat belt out as far as possible to activate the belt's automatic locking function.

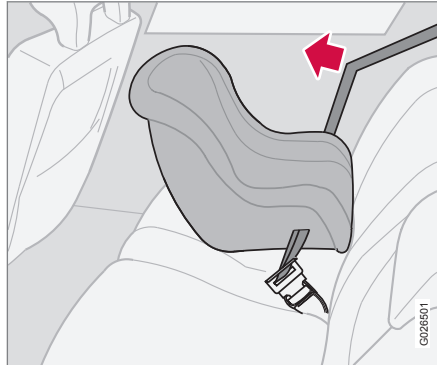

Pull out the shoulder section of the seat belt

NOTE

The locking retractor will automatically release when the seat belt is unbuckled and allowed to retract fully.

5. Press the convertible seat firmly in place, let the seat belt retract and pull it taut. A sound from the seat belt retractor's automatic locking function will be audible at this time and is normal. The seat belt should now be locked in place.
6. Push and pull the convertible seat along the seat belt path to ensure that it is held securely in place by the seat belt.

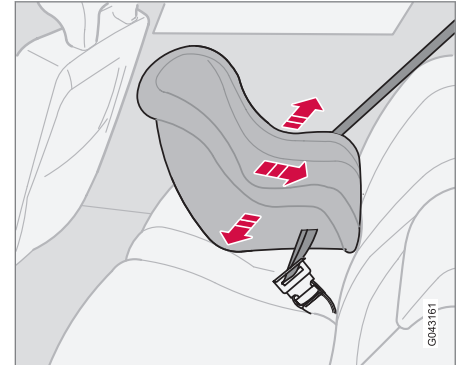

Ensure that the seat is securely in place

WARNING

It should not be possible to move the child restraint (child seat) more than 1 in. (2.5 cm) in any direction along the seat belt path.

The convertible seat can be removed by unbuckling the seat belt and letting it retract completely.

 **WARNING**

A child seat should never be used in the front passenger seat of any vehicle with a front passenger airbag – not even if the **PASSENGER AIRBAG OFF** symbol near the rear-view mirror is illuminated (on vehicles equipped with Occupant Weight Sensor). If the severity of an accident were to cause the airbag to inflate, this could lead to serious injury or death to a child seated in this position.



Booster cushions

Securing a booster cushion

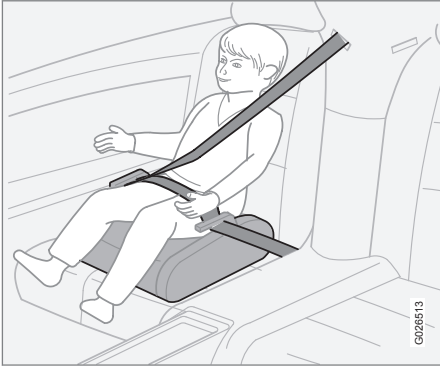

Position the child correctly on the booster cushion

Booster cushions are recommended for children who have outgrown convertible seats.

1. Place the booster cushion in the rear seat of the vehicle.
2. With the child properly seated on the booster cushion, attach the seat belt to or around the cushion according to the manufacturer's instructions.
3. Fasten the seat belt by inserting the latch plate into the buckle (lock) until a distinct click is audible.

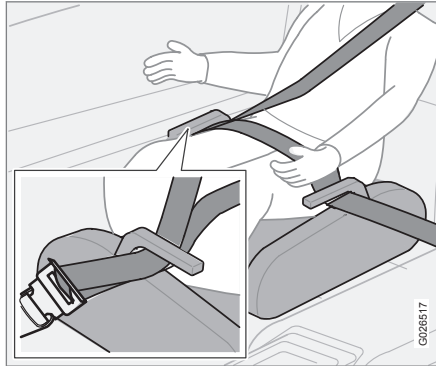

Positioning the seat belt

4. Ensure that the seat belt is pulled taut and fits snugly around the child.



WARNING

- The hip section of the three-point seat belt must fit snugly across the child's hips, not across the stomach.
- The shoulder section of the three-point seat belt should be positioned across the chest and shoulder.
- The shoulder belt must never be placed behind the child's back or under the arm.



ISOFIX/LATCH lower anchors

Using the ISOFIX/LATCH lower child seat anchors

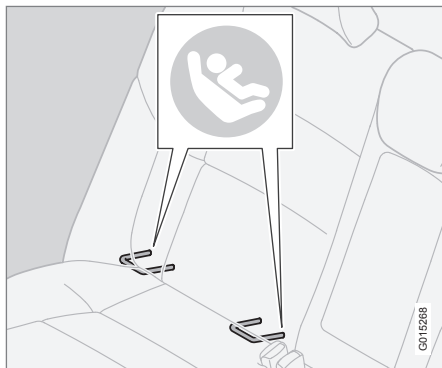

ISOFIX/LATCH lower child restraint anchors

Lower anchors for ISOFIX/LATCH-equipped child seats are located in the second row, outboard seats, hidden below the backrest cushions. Symbols on the seat back upholstery mark the anchor positions (see the illustration).

To access the anchors:

1. Put the child restraint in position.
2. Kneel on the child restraint to press down the seat cushion and locate the anchors by feel.

3. Fasten the attachment on the child restraint's lower straps to the ISOFIX/LATCH lower anchors.
4. Firmly tension the lower child seat straps according to the manufacturer's instructions.

WARNING

Volvo's ISOFIX/LATCH anchors conform to FMVSS/CMVSS standards. Always refer to the child restraint system's manual for weight and size ratings.

WARNING

The ISOFIX/LATCH lower child restraint anchors are only intended for use with child seats positioned in the outboard seating positions. These anchors are not certified for use with any child restraint that is positioned in the center seating position. When securing a child restraint in the center seating position, use only the vehicle's center seat belt.

NOTE

- The rear seat's center position is not equipped with ISOFIX/LATCH lower anchors. When installing a child restraint in this position, attach the restraint's top tether strap (if it is so equipped) to the top tether anchorage point and secure the restraint with the vehicle's center seat belt.
- Always follow your child seat manufacturer's installation instructions, and use both ISOFIX/LATCH lower anchors and top tethers whenever possible.

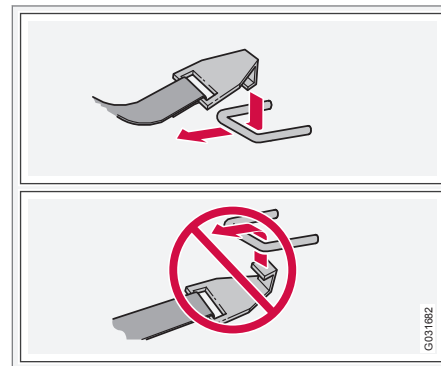

Fasten the attachment correctly to the ISOFIX/LATCH lower anchors



ISOFIX/LATCH lower anchors



WARNING

Be sure to fasten the attachment correctly to the anchor (see the illustration). If the attachment is not correctly fastened, the child restraint may not be properly secured in the event of a collision.



Top tether anchors

Top tether anchors

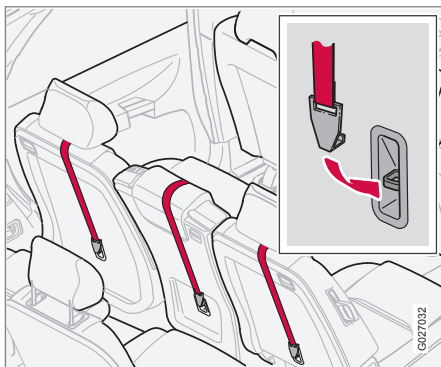

Top tether anchorage points

Your vehicle is equipped with child restraint top tether anchorages in all second row seat positions (second-row seats only in 7-seat models).

Using the top tether anchorages

- Place the child restraint on the rear seat.
- Route the top tether strap under the head restraint and fasten its attachment to the anchorage.

WARNING

Be sure to fasten the child tether attachment correctly to the anchor. If it is not correctly fastened, the child seat may not be properly restrained in the event of a collision.

- Firmly tension the top tether strap according to the child restraint manufacturer's instructions. Tension the top tether strap only after the lower anchor straps or the seat belt have been firmly tensioned.

For securing the child restraint to ISOFIX/LATCH lower anchors, see page 49.

WARNING

- Always refer to the recommendations made by the child restraint manufacturer.
- Volvo recommends that the top tether anchors be used when installing a forward-facing child restraint.
- Never route a top tether strap over the top or around the head restraint. It should always be routed under the head restraint.
- Child restraint anchorages are designed to withstand only those loads imposed by correctly fitted child restraints. Under no circumstances are they to be used for adult seat belts or harnesses. The anchorages are not able to withstand excessive forces on them in the event of collision if full harness seat belts or adult seat belts are installed to them. An adult who uses a belt anchored in a child restraint anchorage runs a great risk of suffering severe injuries should a collision occur.
- Do not install rear speakers that require the removal of the top tether anchors or interfere with the proper use of the top tether strap.



Integrated booster cushion

Integrated booster cushion*



Volvo's own integrated booster cushion has been specially designed to help safeguard a child seated in the rear seat. When using an integrated booster cushion, the child must be secured with the vehicle's three-point seat belt.

Use this booster cushion only with children who weigh between 33 and 80 lbs (15 and 36 kg) and whose height is between 38 and 54 in (97 and 137 cm). In Canada, Transport Canada's weight recommendation is 40 – 80 lbs (18 – 36 kg).

The booster cushion is designed to raise the child higher, so that the shoulder strap

crosses over the child's collarbone, not over the child's neck. If using a booster cushion does not result in proper positioning of the shoulder strap, then the child should be placed in a properly secured child restraint (see page 38 for information). The shoulder belt must never be placed behind the child's back or under the arm.

WARNING

- **Death or serious injury can occur.**
- Follow all instructions on the booster cushion and in the vehicle's owner's manual.
- **Make sure the booster cushion is securely locked before the child is seated.**
- Use this booster cushion only with children who weigh between 33 and 80 lbs (15 and 36 kg) and whose height is between 38 and 54 in (97 and 137 cm). In Canada, Transport Canada's weight recommendation is 40 – 80 lbs (18 – 36 kg).
- In the event of a collision while the integrated booster cushion was occupied, the entire booster cushion and seat belt must be replaced. The booster cushion should also be replaced if it is badly worn or damaged in any way. This work should be performed by an authorized Volvo retailer only.

**Integrated booster cushion****i NOTE**

Canada only: This cushion may be referred to as a built-in booster cushion.

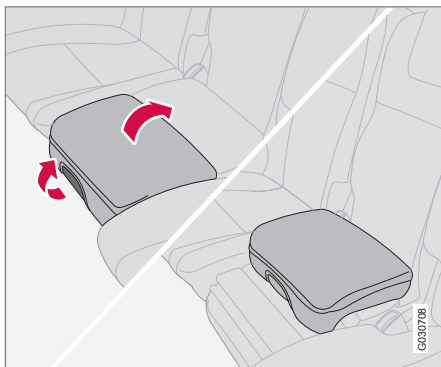
**Lowering**

1. Pull the handle at the front of the cushion forward.
2. Pull the seat forward and press it down until it locks in place.

The booster cushion must be pressed down before the backrest can be folded down.

Raising

1. Pull the handle at the front of the cushion forward.
2. Move the seat belt latch aside before raising the cushion.
3. With both hands push the cushion rearward.
4. Push the cushion until it locks in place.

Instrument overview.....	56
Instrument panel.....	58
Information display.....	62
Center console buttons.....	64
Steering wheel adjustment.....	66
Lighting panel.....	67
Manually unlocking the fuel filler door.....	70
Left-side steering wheel lever.....	71
Right-side steering wheel lever.....	72
Hazard warning flashers.....	75
Trip computer.....	76
Cruise control.....	78
12-volt sockets.....	80
Hood/tailgate.....	81
Power windows.....	82
Mirrors.....	84
Power moonroof.....	87
HomeLink® Wireless Control System*.....	89



G044142

02

INSTRUMENTS AND CONTROLS

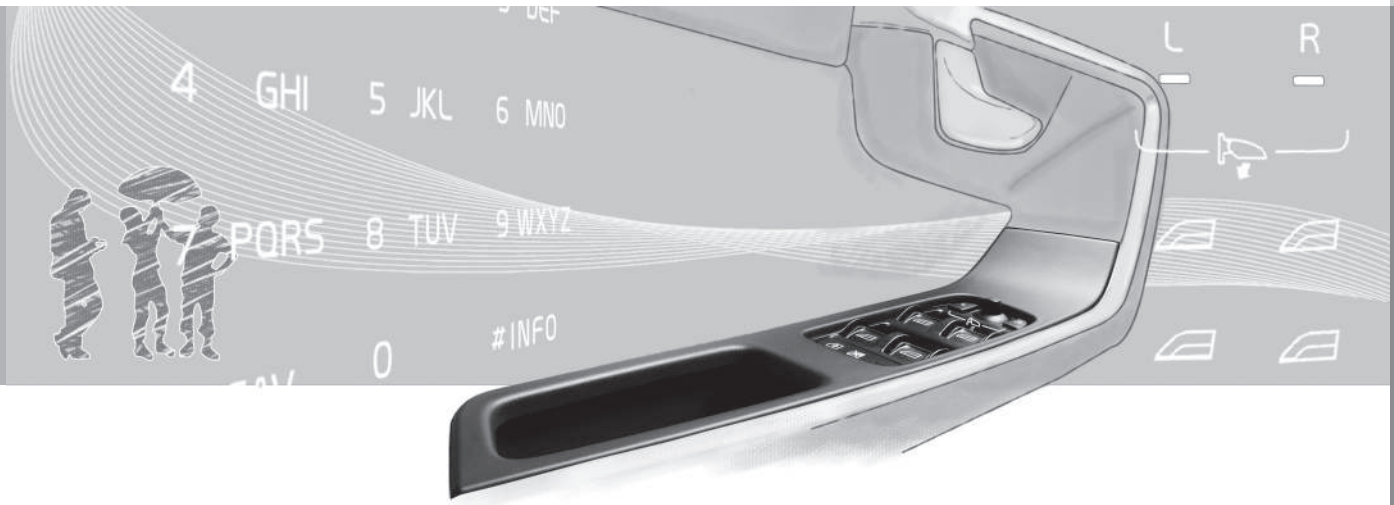



Instrument overview

02

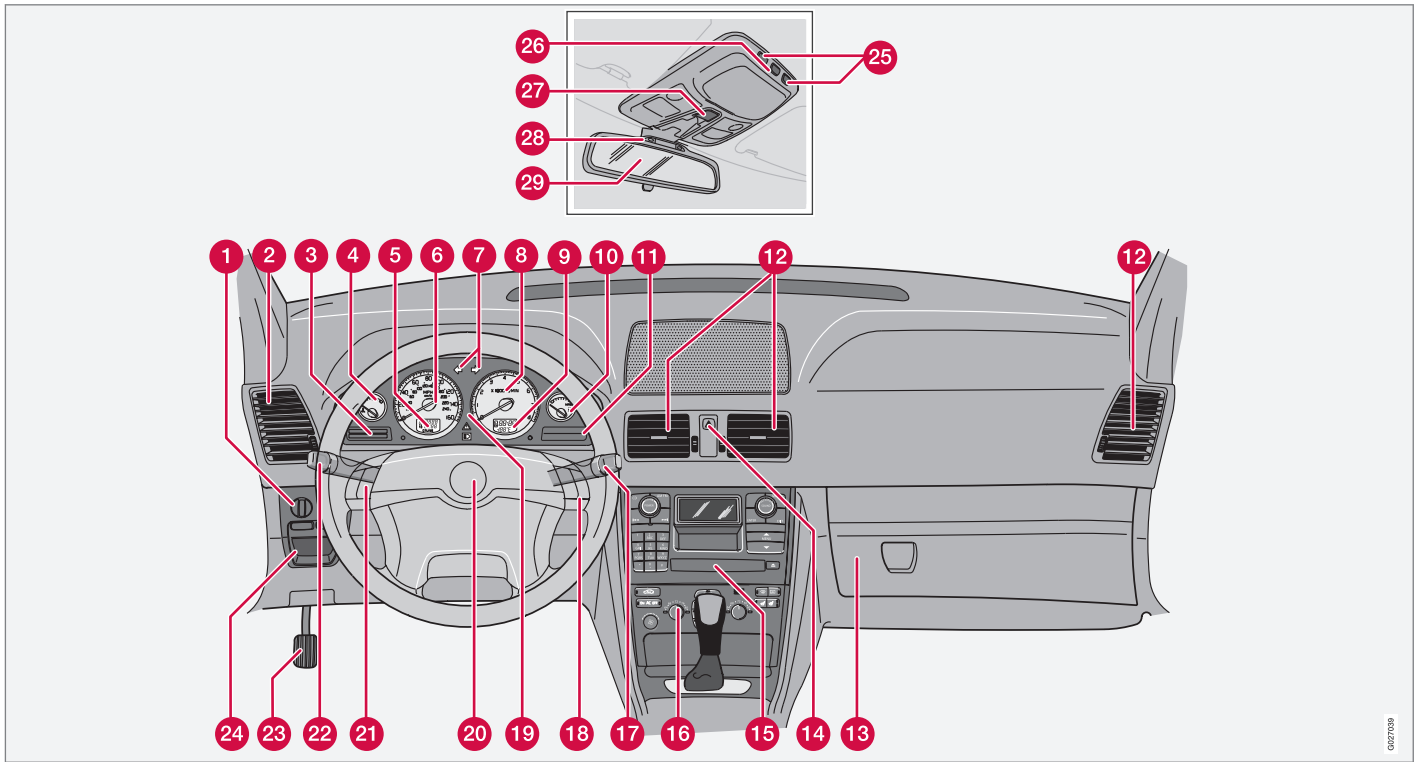

0627039



Instrument overview

- 1 Headlights/Parking lights
- 2 Panel vents
- 3 Display
- 4 Temperature gauge
- 5 Odometer/Trip odometer/Cruise control indicator
- 6 Speedometer
- 7 Turn signal indicator lights
- 8 Tachometer
- 9 Ambient temperature gauge, clock, gear indicator
- 10 Fuel gauge
- 11 Indicator and warning symbols
- 12 Panel vents
- 13 Glove compartment
- 14 Hazard warning flashers
- 15 Audio system
- 16 Climate system controls
- 17 Windshield wiper/washer lever
- 18 Audio control buttons in steering wheel
- 19 Instrument panel
- 20 Horn
- 21 Cruise control buttons in steering wheel
- 22 Turn signals, High/low beams, **READ**-button
- 23 Parking brake pedal
- 24 Parking brake release handle
- 25 Reading lights
- 26 Courtesy light
- 27 Moonroof control*
- 28 Seat belt reminder
- 29 Rearview mirror

Control panel in the driver's door

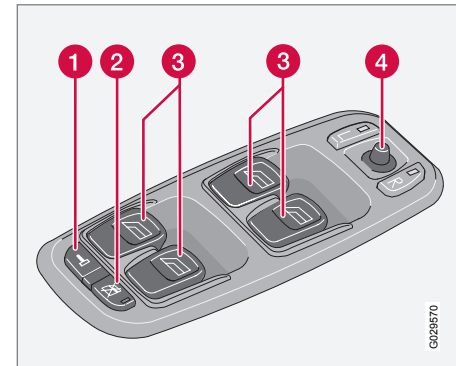

- 1 Central locking button
- 2 Lockout switch for rear seat power windows
- 3 Power window controls
- 4 Door mirror controls

* Option/accessory, for more information, see Introduction.

Instrument panel

Instrument panel

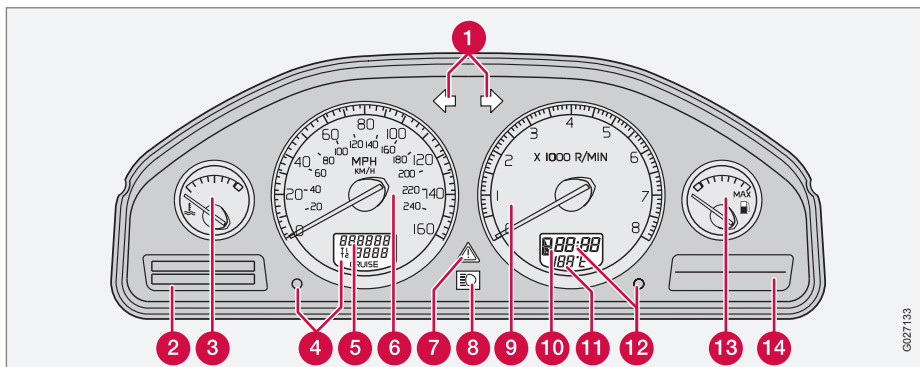

- 1 Turn signal indicators – right/left
- 2 Text window – The text window displays information and warning messages.
- 3 Temperature gauge – The pointer should be approximately midway on the gauge when driving. **Do not drive the vehicle if the warning light is on.** The text window will provide you with additional information. If the engine temperature remains high, check coolant level – see page 224.
- 4 Trip odometer – The trip odometers are used for measuring shorter distances. The right-hand digit gives tenth of a mile/kilometer. Press the button for more than 2 seconds to reset. Change between trip

odometers 1 and 2 using one short press on the button. The display presents information and warning messages, the ambient temperature, and the clock, etc. When the ambient temperature is between 23° and 36 °F (–5° and +2 °C), a snowflake symbol is shown in the display. This symbol serves as a warning for possible slippery road surfaces. Please note that this symbol does not indicate a fault with your car. At low speeds, or when the car is not moving, the temperature readings may be slightly higher than the actual ambient temperature.

- 5 Odometer

- 6 Speedometer
- 7 Warning symbol
- 8 High beam indicator
- 9 Tachometer – The tachometer shows engine speed in thousands of revolutions per minute (rpm). Do not drive continuously with the needle in the red area of the dial, which indicates maximum allowable engine rpm range. Instead, shift to a higher gear or slow the vehicle down. The engine management system will automatically prevent excessively high engines speeds. This will be noticeable as a pronounced unevenness in engine speed.



Instrument panel

- ⑩ Gear and driving mode indicator – The currently selected driving mode is displayed here. If you use the Geartronic function on the automatic transmission, the currently selected gear will be displayed.
- ⑪ Ambient temperature gauge – This display indicates the air temperature outside your vehicle. A "snowflake" symbol in the text window is displayed when the temperature is in the range of 23 – 36 °F (–5 – +2 °C). Please note that this symbol does not indicate a fault with your vehicle. At low speeds or when the vehicle is not moving, the temperature readings may be slightly higher than the actual ambient temperature.
- ⑫ Clock/set button – Turn the button to set the clock.
- ⑬ Fuel gauge – see page 288 for fuel tank volume. When the warning light in the gauge comes on, the vehicle should be refueled as soon as possible. The trip computer section (see page 76) provides more information on fuel level and consumption.
- ⑭ Indicator and warning symbols – The indicator and warning symbols¹light up when

you turn the ignition key to the driving position (position II) before starting.

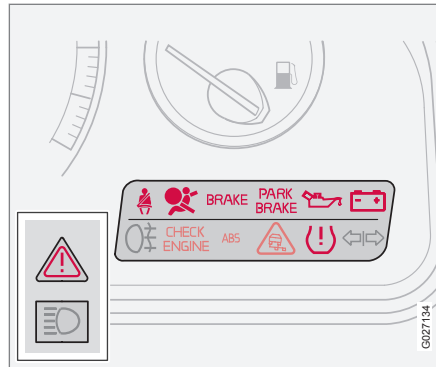

This shows that the symbols are functioning. When the engine starts, all symbols go out. If the engine is not started within 5 seconds, all symbols except **CHECK ENGINE** and  go out. Certain symbols may not have their functions illustrated, depending on the vehicle's equipment. The symbol for the parking brake goes out when the parking brake is released.

Warning/information symbol in center of the instrument panel



This symbol shines as a red or yellow light depending on the nature of the information displayed.

Red symbol – Stop the vehicle as soon as possible in a suitable location and read the message shown in the text window. The symbol and accompanying text will remain on until the fault has been corrected.

Yellow symbol – Follow the instructions shown in the text window. The text can be erased by pressing the **READ** button (see page 62), or will disappear automatically after two minutes.

NOTE

When the message **TIME FOR REGULAR SERVICE** is displayed, the text can be erased and the yellow symbol light can be turned off by pressing the **READ** button. The text will disappear and the symbol light will go out automatically after two minutes.

¹ On certain engines, the symbol for low oil pressure is not used. Instead, a text warning is provided in the information display, see page 222.

Instrument panel

Seat belt reminder



This symbol lights up to indicate that the driver has not fastened his/her seat belt.

Supplemental Restraint System (SRS)



If this light comes on while the vehicle is being driven, or remains on for longer than approximately 10 seconds after the vehicle has been started, the SRS system's

diagnostic functions have detected a fault in a seat belt lock or pretensioner, a front air-bag, side impact airbag, and/or an inflatable curtain. Have the system(s) inspected by a trained and qualified Volvo service technician as soon as possible.

BRAKE – Brake failure warning light

If the light comes on while driving or braking, stop immediately, open the hood and check the brake fluid level in the reservoir. see page 225.



Canadian models are equipped with this warning light.

If the BRAKE and ABS warning lights come on at the same time, this could indicate a fault in the brake system.

- Stop the vehicle in a suitable place and switch off the engine.
- Restart the engine.
- If both warning lights go off, no further action is required.
- If both lights are still on after the engine has been restarted, switch off the engine again and check the brake fluid level (see page 225 for the location of the brake fluid reservoir).

If the brake fluid level is above the **MIN** mark, drive carefully to a trained and qualified Volvo service technician and have the brake system inspected.

WARNING

If the fluid level is below the **MIN** mark in the reservoir or if a **Brake failure – Service urgent** message is displayed in the text window: **DO NOT DRIVE**. Have the vehicle towed to a trained and qualified Volvo service technician and have the brake system inspected.

PARK BRAKE Parking brake applied

This light will be on when the parking brake (hand brake) is applied. The parking brake pedal is located on the left side of the driver's footwell, see page 80 for more information.



Canadian models are equipped with this symbol.

Oil pressure warning light²



If the light comes on while driving, stop the vehicle and then stop the engine immediately and check the engine oil level, see page 62. If the light stays

on after restart, have the vehicle towed to the nearest trained and qualified Volvo service technician. After hard driving, the light may come on occasionally when the engine is idling. This is normal, provided it goes off when the engine speed is increased.

Generator warning light

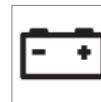

If the light comes on while the engine is running, have the charging system checked.

² On certain engines, the symbol for low oil pressure is not used. Instead, a text warning is provided in the information display, see page 62.



Rear fog light

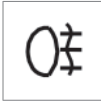

This light indicates that the fog light is on.

CHECK ENGINE Malfunction indicator light

On-Board Diagnostics II (OBDII): As you drive, a computer called "OBDII" monitors your vehicle's engine, transmission, electrical and emission systems. The **CHECK ENGINE** light will light up if the computer senses a condition that potentially may need correcting. When this happens, please have your vehicle checked by a trained and qualified Volvo service technician as soon as possible.

A **CHECK ENGINE** light may have many causes. Sometimes, you may not notice a change in your vehicle's behavior. Even so, an uncorrected condition could hurt fuel economy, emission cleanliness, and driveability. Extended driving without correcting the cause could even damage other components in your vehicle.

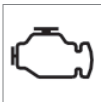

Canadian models are equipped with this symbol for the Malfunction Indicator Light.

ABS (Anti-lock brake system)



If the warning light comes on, there is a malfunction of the ABS system (the standard braking system will still function). The vehicle should be driven to a trained and qualified Volvo service technician for inspection. See page 154 for additional information.

DSTC system



The Dynamic Stability and Traction Control system (DSTC) is explained in greater detail on page 158.

Tire pressure monitoring light



See page 203 for more information on this function.

Turn signal indicator – trailer (certain models)



If you are towing a trailer, this light will flash simultaneously with the turn signals on the trailer. If the light does not flash when signaling, neither the trailer's turn signals nor the vehicle's turn signals are functioning.



Information display

Message in the text windows

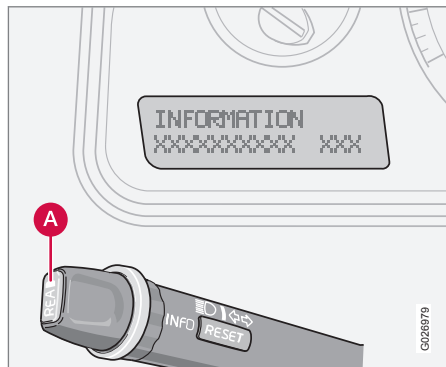

When a warning light in the instrument panel comes on, a message is also displayed in the text window. After you have read the message, you can erase it by pressing button A (see illustration).

i NOTE

Certain messages cannot be erased until the condition has been corrected.

If a warning message is displayed when e.g. you are using the trip computer, this message must be erased before you can access the function of your choice. Press button A to erase the warning message.

You can scroll through the stored messages by pressing button A (see illustration). The text window can be cleared (the message will be returned to memory) by pressing button A again.

Message	Meaning
BRAKE FAILURE STOP SAFELY^A	Stop the car in a safe place and switch off the engine to help prevent the risk of serious damage.
COOLANT LOW STOP ENGINE^B	Stop the car in a safe place and switch off the engine to help prevent the risk of serious damage.
BRAKE FLUID LOW SERVICE URGENT^C	Take your vehicle to a trained and qualified Volvo service technician for inspection immediately.
HIGH ENGINE TEMP SEE MANUAL^D	Refer to your owner's manual. For additional information, please contact your Volvo retailer.



Information display

Message	Meaning
ABS SERVICE REQUIRED^E	Take your vehicle to a trained and qualified Volvo service technician for inspection at your convenience (but preferably before the next scheduled maintenance service).
TIME FOR REGULAR MAINTENANCE	This message will be displayed at 10,000 mile (16,000 km) intervals, after 500 hours of driving or after 12 months, whichever occurs first, to remind the driver that the service interval has been exceeded. The message will be displayed for 2 minutes each time the vehicle is started until reset by a trained and qualified Volvo service technician.
DSTC SPIN CONTROL OFF	The stability system's spin control function has been turned off, see page 158 for details.

^A This is one example of several similar texts containing "stop safely"

^B This is one example of several similar texts containing "stop engine"

^C This is one example of several similar texts containing "service urgent"

^D This is one example of several similar texts containing "see manual"

^E This is one example of several similar texts containing "service required"



Center console buttons

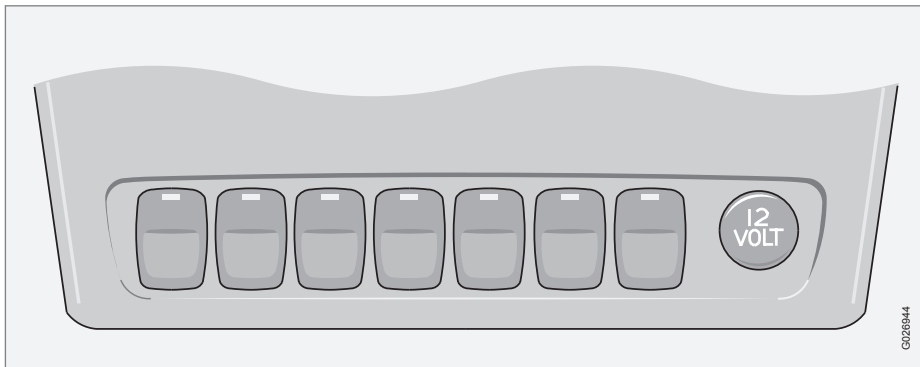

G02E944

02

Active Bending Lights*



The beams of these headlights adjust laterally to help light up a curve according to movements of the steering wheel when the vehicle is turning.

This function is activated automatically when the engine is started and can be deactivated/reactivated by pressing the button. The indicator light in the button is on when the function is activated, also see page 67.

Rear seat air conditioning*



This button controls the optional rear seat air conditioning system.

Folding door mirrors*



Press the button and release it to fold the door mirrors in or out. On certain models, when the button is pressed, there may be a long pause before the mirrors move. Pressing the button again during this pause may erase your first button press. If this happens, wait ten seconds and press the button one more time.

The mirrors cannot be adjusted during the first ten seconds after they have been folded out.



Center console buttons

i NOTE

If the door mirrors have been inadvertently pushed out of position (in a car wash, parking lot, etc.) manually return them to normal position. If mirror adjustment does not seem to operate after manual folding, reset the folding mirrors as follows:

- Turn the ignition key to position **II**.
- Manually fold the mirror(s) to the normal position.
- Press the button to fold both mirrors in.
- Press the button again to fold the mirrors out to their normal position.

Park Assist*

This system provides an audible warning when the vehicle is being parked or if it is driven close to a person or object. For more information see page 160.

i NOTE

The system activates automatically when the engine is started, and can be deactivated by pressing this button (e.g. when towing a trailer) or reactivated if necessary.

Auxiliary lights

This button is used to switch on auxiliary lights (if installed). A light in the button will light up to indicate that the auxiliary lights are illuminated.

12-volt sockets

The 12-volt sockets can be used to plug in certain accessories such as cell phones, etc. The ignition key must be in position **I** (or higher) for the auxiliary socket to function.

The maximum current consumption is 10A (120W) if only one of the 12-volt sockets is in use. If both the front and rear sockets are used at the same time, the maximum current consumption per socket is 7.5A (90W).

i NOTE

The auxiliary sockets can also be used for cigarette lighters, which are available as accessories at your Volvo retailer.

Power child locks*

For more information on this function, see page 132.



Steering wheel adjustment

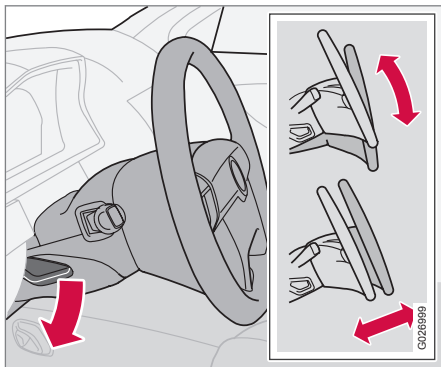

Both the height and the reach of the steering wheel can be adjusted to a comfortable position for the driver. Pull down the lever on the left of the steering column. Adjust the steering wheel to a suitable position and press the lever back into place to lock the steering wheel in the new position. Check that the steering wheel is locked in the new position.

WARNING

Never adjust the steering wheel while driving.



Lighting panel

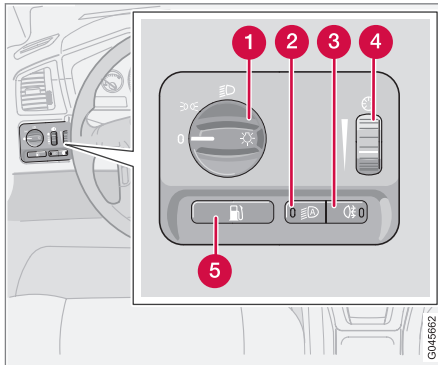

- 1 Headlight/parking light switch
- 2 LED daytime running lights (DRL) in front spoiler
- 3 Rear fog light
- 4 Instrument panel lighting
- 5 Fuel filler door unlock button

Pos.	Lighting
0	Headlights off ^A . Pull the left-side steering wheel lever to flash the high beam headlights.
	Parking lights (the LED daytime running lights in the front spoiler do not function with the switch in this position ^B)
	Low beam headlights and parking lights on. Pull the left-side steering wheel lever to toggle between high and low beams. If the vehicle is equipped with the optional Active Bending Lights (ABL), this feature will also be activated with the light switch in this position. The switch must also be in this position for the LED daytime running lights to function (see page 68).

^A On Canadian models, the LED daytime running lights in the front spoiler will be on.

^B On Canadian models, the LED daytime running lights in the front spoiler will remain on.

Headlights

To illuminate the headlights, the ignition key must be turned to at least position **II** and the headlight switch must be in position

For information on switching between high and low beams, see page 71.

Active Bending Lights (ABL)*

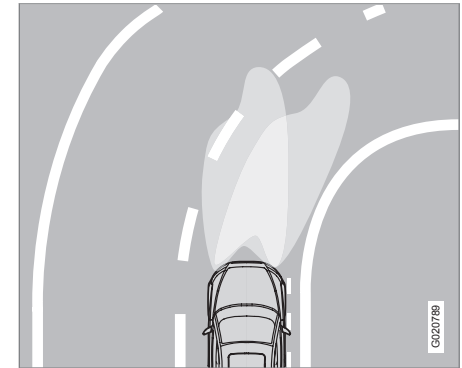

Headlight pattern with the Active Bending Light function deactivated (left headlight beam) and activated (right headlight beam)

When this function is activated, the headlight beams adjust laterally to help light up a curve according to movements of the steering



Lighting panel

wheel (see the right-pointing beam in the illustration).

NOTE

When driving in daylight conditions, the headlights will switch off and the daytime running lights will come on. In darkness, the daytime running lights will switch off and the Active Bending Lights will switch on.

The ABL function is activated automatically when the engine is started and the headlight switch is in the  position and can be deactivated/reactivated by pressing the button in the center console (see page 64).

LED Daytime Running Lights (DRL)

To help conserve fuel by reducing the use of electrical current in the vehicle, DRL can be used in daylight conditions instead of the low beam headlights, which consume more electrical current. The daytime running lights are mounted in the front spoiler and use bright, electricity-saving LEDs (light emitting diodes).

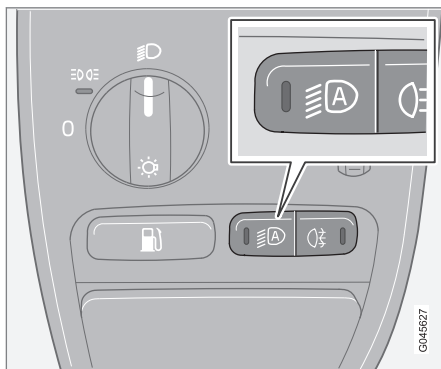

Press button **A** to activate automatic DRL in daylight driving conditions

With the headlight switch in the  position as shown in the illustration, press the button with the **A** symbol to activate the automatic LED daytime running lights in daylight driving conditions (the indicator light in the button will illuminate). A light sensor then monitors the ambient lighting conditions and automatically switches from LED DRL to the low beam headlights in weaker ambient light (and will switch back to DRL when the ambient light becomes brighter). Press the button again (the indicator light in the switch will turn off) to switch on the headlights.

The LED DRLs will also switch off automatically (and the low beams will switch on) if:

- The rear fog light is switched on
- The windshield wipers are switched on for more than 10 seconds

If the LED DRL function was activated when the ignition was switched off, it will be active when the ignition is switched on again.



WARNING

- DRL is a driving aid designed to help conserve electrical current. This system cannot always determine if the ambient lighting conditions are sufficient for switching from low beams to DRL (or vice versa). It is always the driver's responsibility to visually determine if the low beam headlights should be used.
- As the driver, you have full responsibility for operating the vehicle in a safe manner.



Lighting panel

Parking lights

The front and rear parking lights can be turned on even when the ignition is switched off.

- Turn switch (1) to position .

The license plate lights also illuminate when the parking lights are switched on.

Rear fog light

The single rear fog light is located in the driver's side of the vehicle.

The rear fog light will only function in combination with the high/low beam headlights.

1. Turn the ignition key to position **II**.
2. Press button (3) to turn on the rear fog light.

An indicator light in the button illuminates when the rear fog light is on.

i NOTE

The rear fog light is considerably brighter than the normal tail lights and should be used only when conditions such as fog, rain, snow, smoke or dust reduce visibility for other vehicles to less than 500 ft. (150 meters).

Instrument panel lighting

The instrument panel lighting illuminates when the ignition key is in position **II** and the light switch (1) is in either position  **0** or



- Move the thumb wheel (4) up to increase brightness or down to decrease brightness.

Unlocking the fuel filler door

Press button (5) when the vehicle is at a standstill to unlock the fuel filler door. Please note that the fuel filler door will remain unlocked until the vehicle begins to move forward. An audible click will be heard when the fuel filler door relocks.

i NOTE

If the fuel filler door does not unlock after the button has been pressed, drive the vehicle at a speed of at least 5 mph (8 km/h), stop the vehicle, and press the button again.

For information on unlocking the fuel filler door manually, see page 70.



Manually unlocking the fuel filler door

02

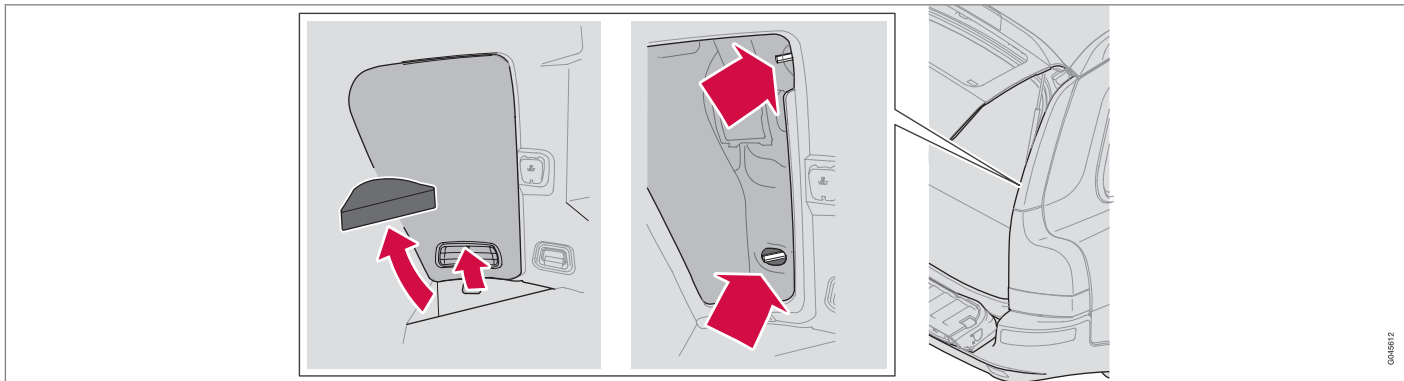

Panel on passenger's side of cargo area

To manually unlock the fuel filler door

1. Open the upper and lower sections of the tailgate, and fold up the rear section of the cargo area floor.
2. If the vehicle is equipped with the optional grocery bag holder, detach the holder's bands.
3. Remove the corner panel from the floor of the cargo area.
4. Open the cover in the side panel by pulling the tab upward/outward.
5. Pull down the insulating material to access the fuel filler door motor.

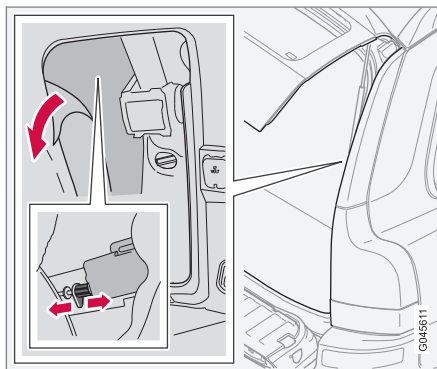

6. Move the catch rearward to unlock the fuel filler door lock, or move it forward to lock the filler door.



Left-side steering wheel lever

Lever positions

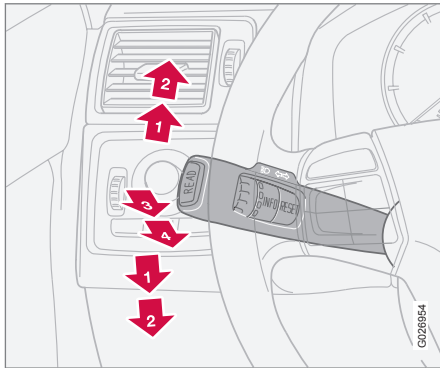

- 1 Turn signals, lane change position
- 2 Turn signals, position for normal turns
- 3 High beam flash
- 4 Toggle between high and low beams, Home Safe lighting

Turn signals

When turning

Move the lever as far up or down as possible (to position 2) to start the turn signals. The turn signals will be cancelled automatically by the movement of the steering wheel, or the lever can be returned to its initial position by hand.

When changing lanes

The driver can automatically flash the turn signals 3 times by:

- Moving the turn signal lever up or down to position (1) and releasing it.
- Moving the lever up or down to position (2) and immediately back to its original position.

i NOTE

- This automatic flashing sequence can be interrupted by immediately moving the lever in the opposite direction.
- If the turn signal indicator flashes faster than normal, check for a burned-out turn signal bulb.

High/low beam headlights

Continuous high beams

1. Turn the ignition key to position II.
2. With the light switch in position , (see page 67) pull the turn signal lever toward the steering wheel to toggle between high and low beams.

High beam flash

1. Turn the ignition key to position II.
2. Pull the turn signal lever to position (3). The high beams will remain on until the lever is released.

Home safe lighting

When leaving your vehicle at night, home safe lighting can illuminate the area in front of the vehicle.

1. Remove the key from the ignition switch.
2. Pull the turn signal lever as far as possible toward the steering wheel and release it.
3. Exit the vehicle and lock the doors.

The headlights and parking lights will illuminate and remain on for 30¹, 60 or 90 seconds. The time interval can be changed by a trained and qualified Volvo service technician.

¹ Factory setting

Right-side steering wheel lever

Windshield wipers

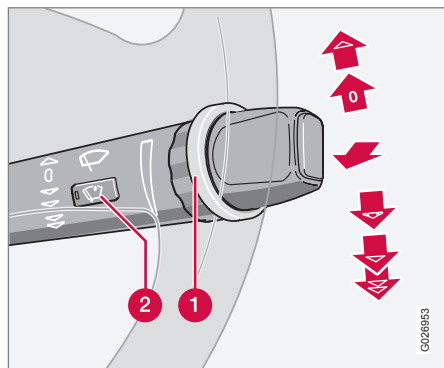

- 1 Thumb wheel
- 2 Rain sensor on/off

Windshield wipers off



If the lever is in the **0** position and you move it upwards, the wipers will sweep one stroke at a time for as long as you hold the lever up.

Single sweep position



Move the lever slightly upward from the **0** position for one sweep of the wipers. The lever returns automatically to **0** when released.

Intermittent wiper function



With the lever in this position, you can set the wiper interval by twisting the control ring (1) upward to increase wiper speed or downward to decrease the speed.

Windshield washer/headlight washer (certain models)

When the lever is pulled to wash the windshield, high pressure jets mounted in the bumper will spray the headlights.



CAUTION

- Use ample washer fluid when washing the windshield to avoid scratching the glass. The windshield should be thoroughly wet when the wipers are in operation.
- Before using the wipers, ice and snow should be removed from the windshield/rear window. Be sure the wiper blades are not frozen in place.
- To conserve washer fluid in driving conditions where the windshield washers are used frequently, the headlights will only be washed once for every five times the

windshield is washed within a 10-minute period.

- A short pull on the lever will wash the windshield only.
- When approximately 1 US quart (1 liter) remains in the washer fluid reservoir, the headlights will not be washed when the lever is pulled to conserve washer fluid for the windshield. A text message will also be displayed to remind the driver to fill the washer fluid reservoir.

Continuous wiper function



Top arrow: normal speed

Bottom arrows: higher speed



Right-side steering wheel lever

Tailgate wiper/washer

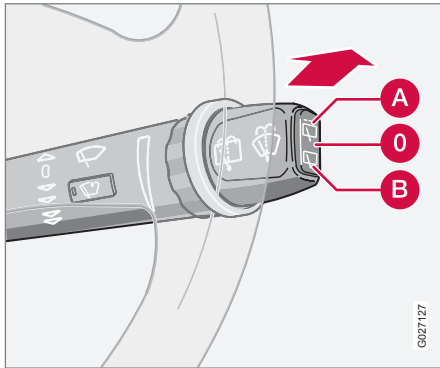

- A** Intermittent wiping: Press the upper section of the switch
- 0** Neutral position: The wiper is switched off
- B** Normal (continuous) wiping: Press the lower section of the switch

Move the lever forward to start the tailgate washer. After washing the rear window, the wiper will make several additional sweeps.

Tailgate wiper and reverse gear

If the front wipers are on and the transmission is put into reverse gear, the tailgate wiper will go into intermittent wiping function¹.

If the tailgate wiper is already in normal wiping function, the normal wiping function will continue.

Rain sensor*

The rain sensor automatically regulates wiper speed according to the amount of water on the windshield.

The **sensitivity** of the sensor can be adjusted by twisting ring (1) up (the wipers will sweep the windshield more frequently) or down (the wipers will sweep the windshield less frequently).

Activating the rain sensor:

1. Turn the ignition key to at least position **I** and put the windshield wiper lever in position **0**.
2. Press button (2), see page 72.
 - > A light in the button will light up to indicate that the rain sensor is active.

Deactivating the rain sensor:

- Press button (2), see page 72.

or

- Move the windshield wiper lever **down** to another position. Moving the lever up will not deactivate the rain sensor. Doing so will cause the wipers to sweep the windshield until the lever is released, at which time the wipers return to rain sensor mode.

The rain sensor is also deactivated when the key is removed from the ignition.



CAUTION

The rain sensor should be deactivated when washing the vehicle in an automatic car wash, etc. If the rain sensor function is left on, the wipers will start inadvertently in the car wash and could be damaged.

¹ Consult your Volvo retailer if you would like to have this function deactivated.



Right-side steering wheel lever

IR-reflecting windshield*

coating (see the area marked in the illustration).

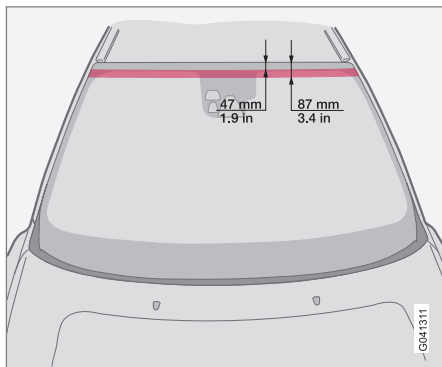

Section of the windshield where the IR-coating is not applied

An optional factory-installed infrared (IR) coating can be applied to the windshield to help protect the cabin from the sun's heat and the fading effect of sunlight on upholstery, panels, etc.

Electronic equipment such as garage door openers, electronic toll tags and similar devices should not be placed on sections of the windshield with the IR coating because this could affect their function and limit their range.

For best performance, place the device on the section of the windshield without the IR



Hazard warning flashers

Hazard warning flashers

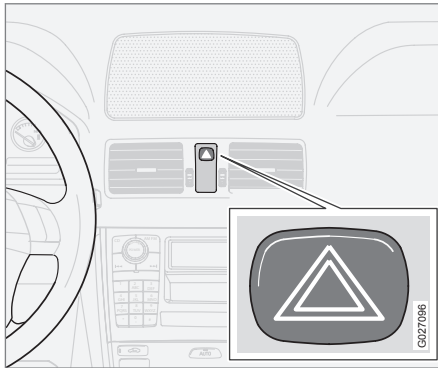

The four-way flasher should be used to indicate that the vehicle has become a traffic hazard. To activate the flashers, press the triangular button in the center dash. Press the button again to turn off the flashers.

i NOTE

Regulations regarding the use of the hazard warning flasher may vary, depending on where you live.

Rear window and door mirror defroster

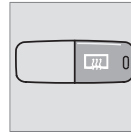

Press the switch to start heating the rear window and door mirrors to remove ice or condensation. A light in the switch will light up.

A timer automatically switches off the heating after approximately 12 minutes. The LED will go out correspondingly.

Trip computer

Trip computer*

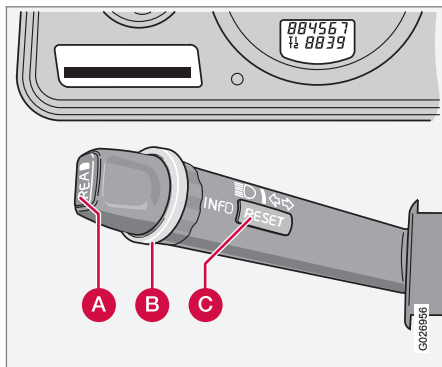

- A READ** (press to acknowledge/confirm/erase a message)
- B** Thumb wheel (used to scroll among the trip computer menus)
- C RESET**

The trip computer stores information gathered from several systems in your vehicle and has four menus that can be displayed in the text window.

- Driving distance on current fuel reserve
- Average fuel consumption
- Current fuel consumption
- Average speed

- Current speed in mph (Canadian models only)
- DSTC (see page 158 for detailed information)

i NOTE

Warning messages from the vehicle's monitoring systems will override the trip computer function. If a warning message is displayed in the text window while you are using the trip computer, you must acknowledge the message by pressing button **A**. Press button **A** again to return to the trip computer function.

1. Trip computer controls and functions

The trip computer functions can be accessed by twisting **INFO** (**B**) one step at a time in either direction. Twisting a final time returns you to the original function.

The trip computer can be reset (current data will be erased from system memory) by pressing **RESET** (button **C**).

2. Driving distance on current fuel reserve

This function shows the approximate distance that can be driven on the fuel remaining in the tank. The calculation is based on average fuel consumption during the last 20 miles (30 km) of driving and the amount of fuel

remaining in the tank when the reading was taken.

When "----" is displayed in the text window, refuel as soon as possible.

3. Average fuel consumption

This value indicates fuel consumption since the last time the trip computer was reset (by pressing **RESET**, button **C**). When the engine is switched off, information on fuel consumption is stored and remains in system memory until the **RESET** (button **C**) is pressed again.

4. Current fuel consumption

This value indicates the current fuel consumption, based on readings taken once per second. When the vehicle is not moving, "----" will be displayed.

5. Average speed

This value indicates average speed since the last time the trip computer was reset (by pressing **RESET**, button **C**). When the engine is switched off, information on average speed is stored and remains in system memory until the **RESET** (button **C**) is pressed again.

**Trip computer****6. Current speed in miles per hour
(Canadian models only)**

This function provides the driver with an instantaneous conversion of the vehicle's current speed from km/h to mph.

 NOTE

Trip computer readings may vary slightly depending on the circumference of the tires on the vehicle and driving style.



Cruise control

Engaging the cruise control function

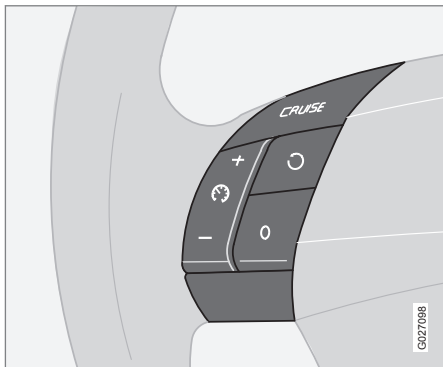

The cruise control panel is located on the left side of the steering wheel hub.

i NOTE

This does not set the vehicle's speed.

1. Press the **CRUISE** button.
 - > **CRUISE** will be displayed in the information window in the instrument panel.
2. Press + or – to set the current speed.
 - > **CRUISE-ON** will be displayed in the information window in the instrument panel.

Increasing or decreasing speed

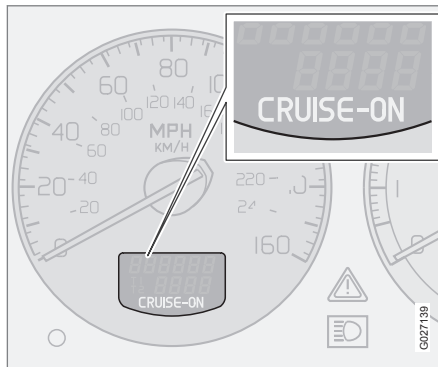

Use + or – in the following ways to increase or decrease the vehicle's speed:

1. Press and hold down + or – until the vehicle reaches the desired speed.
2. Press + or – for approximately a half second and release the button to increase or decrease vehicle speed by approximately 1 mph (1.6 km/h).

i NOTE

Cruise control will not function at speeds below 20 mph. (30 km/h).

Braking

- Cruise control is automatically disengaged when the brake pedal is depressed. The currently set speed is stored in memory.
- Pressing resume  will return the vehicle to the previously set speed.

Acceleration

Momentary acceleration, such as when passing another vehicle, does not affect cruise control operation. The vehicle will automatically return to the previously set speed when you release the accelerator pedal.

Disengaging cruise control

To disengage cruise control, press the **CRUISE** button. **CRUISE** or **CRUISE-ON** will no longer be displayed in the information window in the instrument panel.



Cruise control

 NOTE

Cruise control is automatically disengaged if:

- When the brake pedal is depressed.
- the engine is switched off
- the gear selector is placed in (N) Neutral
- the wheels start to spin or lock
- if an increase in speed is maintained for more than one minute
- if the vehicle's speed falls below approximately 20 mph (30 km/h).

 WARNING

Cruise control should not be used in heavy traffic or when driving on wet or slippery roads, or when driving on unpaved or uneven road surfaces. Cruise control may not maintain set speed on steep down-grades.

02

Temporarily disengaging the cruise control

1. Press **0** to temporarily disengage cruise control.
 - > **CRUISE** will be displayed in the information window in the instrument panel.
2. Depress the brake pedal.

Pressing "resume"  causes the vehicle to return to the previously set speed.



12-volt sockets

These 12 volt sockets can be used to plug in certain accessories such as cellular telephones, etc.

The ignition key must be in at least position I for the sockets in the front seat and the optional socket at the rear of the center console to function.

The maximum current consumption is 10A (120W) if only one of the 12-volt sockets in the passenger compartment is in use. If both the front and rear sockets are used at the same time, the maximum current consumption per socket is 7.5A (90W).

12-volt socket in the cargo compartment

Fold down the lid to use the socket. This socket can be used even if the ignition is switched off.

NOTE

- If the 12-volt sockets are used while the engine is not running, there is a risk that the vehicle's battery will be discharged.
- If the ignition is switched off and a device drawing more than 0.1 A is connected to a socket, a battery warning will be displayed in the text window.
- The covers should be kept on when the auxiliary sockets are not in use.

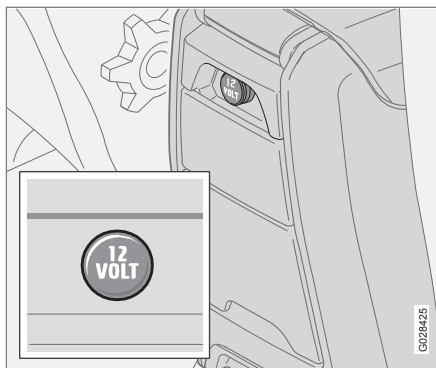

12-volt socket at the rear of the center console*

Ashtrays/cigarette lighter

The auxiliary socket can also be used to power a cigarette lighter. Accessory cigarette lighters and ashtrays can be purchased from your Volvo retailer.

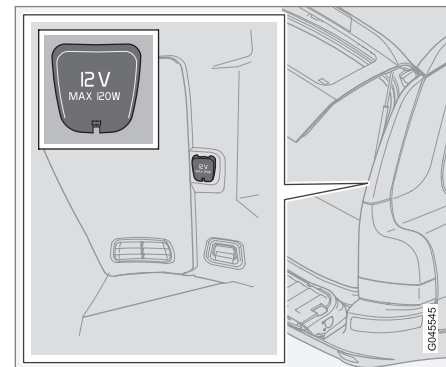

12-volt socket in the cargo compartment



Hood/tailgate

Opening/closing the hood

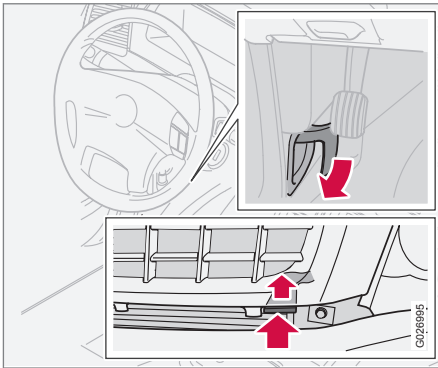

Opening the hood

1. Pull the lever located under the left side of the dashboard to release the hood lock.
2. Lift the hood slightly.
3. Press up the release control located under the front edge of the hood and lift.

To close the hood, place your hand on it and press down until the hood locks in the closed position.

 **WARNING**

- Do not grasp the ribs in the grille when closing the hood. If your fingers protrude through the grille, they could be injured on components in the engine compartment as the grille closes. We recommend pressing down on the hood to close it.
- Check that the hood locks properly when closed!

Opening the tailgate

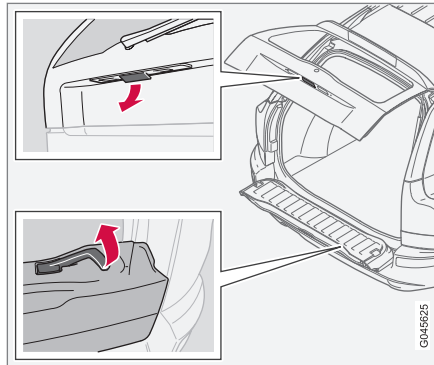

To open the upper section of the tailgate, pull the handle downward.

To fold down the lower section of the tailgate, pull handle upward.



Power windows

Power windows

The power windows are controlled by buttons in the arm rests. The ignition switch must be ON¹ (ignition key in position I, II or the engine running) for the electrically operated windows to function.

To lower: Press down the front edge of the button to the first detent ("stop").

To raise: Lightly pull up the front edge of the button to the first detent ("stop").

Auto up/down function (front doors only):

Either front door window can be opened or closed automatically.

Auto down: Press the front part of the button as far down as possible and release it immediately. To stop the window at any time, pull the button up.

Auto up: Pull the front part of the button up as far as possible and release it immediately. To stop the window at any time, press the button down.

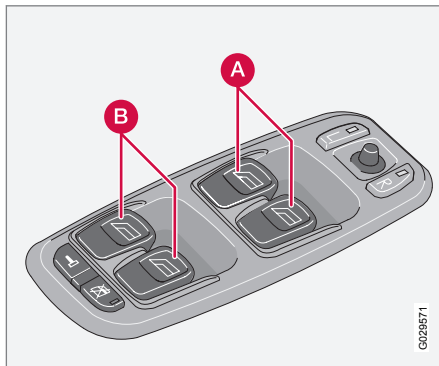

Power window controls

- A** Front windows
- B** Rear windows

i NOTE

If a window is obstructed during auto-up, it will automatically reverse direction and return to its starting position. If a window is repeatedly obstructed during auto-up operation, an overload protection circuit breaker will temporarily halt window function. The window will return to normal function after a brief cool-down period.

! WARNING

Always remove the ignition key when the vehicle is unattended.

Make sure that the windows are completely unobstructed before they are operated.

Never leave children unattended in the vehicle.

i NOTE

To reduce buffeting wind noise if the rear windows are opened, also open the front windows slightly.

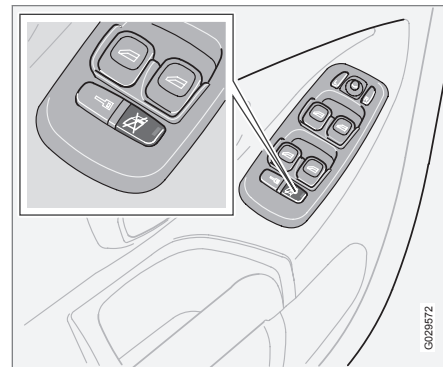

¹ The power windows will also function after the ignition has been switched off as long as neither of the front doors has been opened.



Power windows

02

Lockout switch for rear windows

The power rear door windows can be disabled by a switch located on the driver's door (see illustration).

If the light in the switch is OFF: The rear door windows can be raised or lowered with the buttons on the rear door armrests or with the buttons on the driver's door armrest.

If the light in the switch is ON: The rear door windows can only be raised or lowered with the buttons on the driver's door armrest.

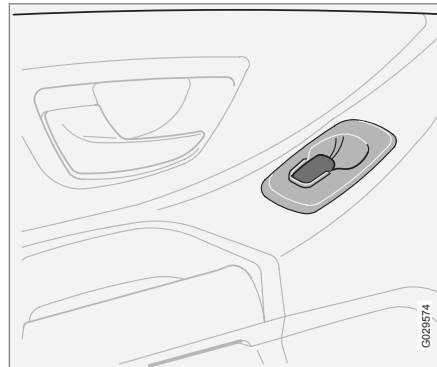
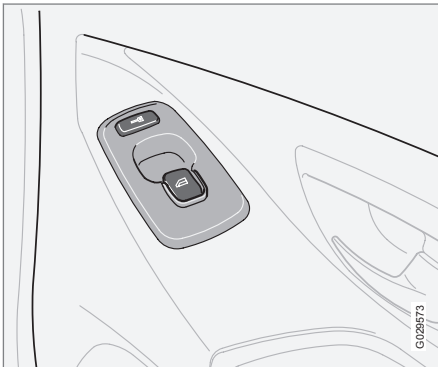

Power windows in the rear doors

The rear door windows can be operated with the control on each door and the switch on the driver's door. If the light in the switch for blocking power windows in the rear doors (located in the driver's door control panel) is on, the rear door windows can only be operated from the driver's door.

Power window on the front passenger's side

The control for the power window in the front passenger's seat operates that window only.

Mirrors

Rearview mirror

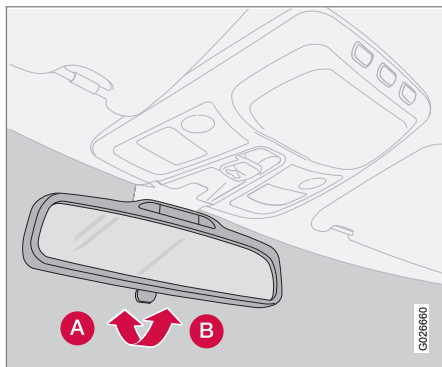

To reduce glare from the headlights of following vehicles, use the control to switch between the normal and night-driving positions.

- A** Normal position
- B** Night position, reduces glare from following headlights

Autodim function*

The autodim function reacts to headlights from following traffic and automatically reduces glare.

NOTE

This function is automatically switched off when the gear selector is placed in the Reverse position.

Rearview mirror with compass*

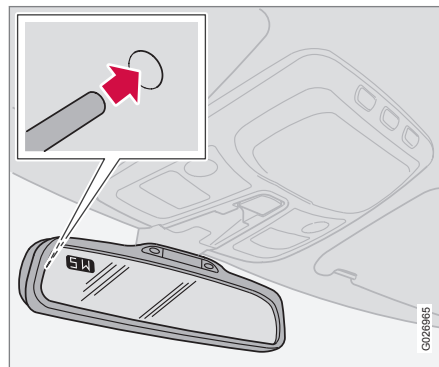

The upper left-hand corner of the rearview mirror has an integrated display that shows the compass direction toward which the car is pointing. Eight different directions can be displayed: **N, NE, E, SE, S, SW, W** and **NW**. The display shows your car's orientation with respect to true north.

If the compass is activated, it will be displayed automatically when the ignition is in position II or when the engine is running. The compass can be switched off or on by pressing the inset button on the rear side of the mirror (see the inset illustration). This can be done with straightened paperclip or similar object. The button is recessed approximately 1 in. (2.5 cm) in the mirror.

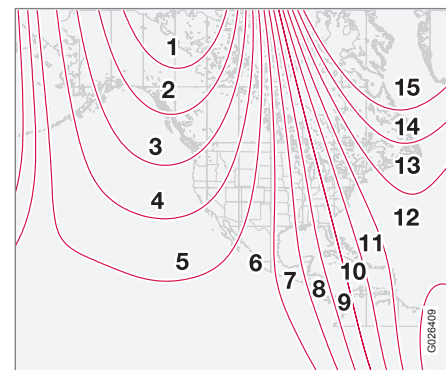

Magnetic zones

The earth is divided into 15 magnetic zones. The compass is initially set for the zone to which the car was delivered, and should always be adjusted if the car is driven to a new magnetic zone. To do so:



Mirrors

1. Switch the ignition to position **II**.
2. Press the button on the rear side of the mirror with straightened paperclip or similar object for approximately 3 seconds until **ZONE** is displayed. The number of the current magnetic zone will also be displayed.
3. Press the button repeatedly until the number for the desired zone (1 – 15) is displayed.

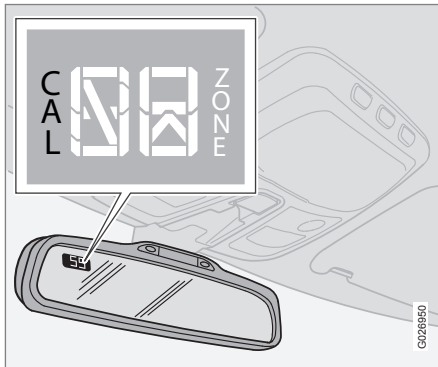

Calibrating the compass

After several seconds, the compass heading will again be displayed, and the change of magnetic zones is complete.

Calibrating the compass

1. Stop the car in a large, open area, away from traffic.
2. Turn off as many electrical devices in the car as possible to avoid interference with the compass (e.g. audio system, etc).
3. Using a pen or similar object, hold the button (on the rear side of the mirror) depressed for at least 6 seconds. "**CAL**" will be displayed.
4. Drive slowly in a circle at a maximum speed of 5 m.p.h. (8 km/h) until **CAL** is no longer displayed.

i NOTE

This step can also be done by driving normally until **CAL** is no longer displayed.

Calibration is complete.

Power door mirrors

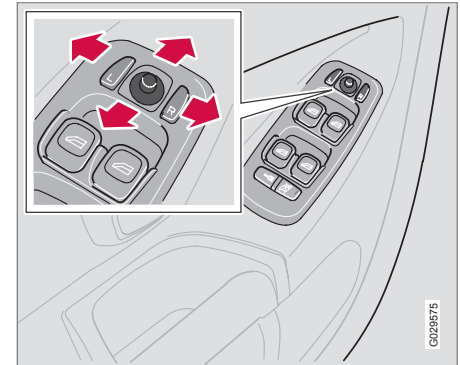

The mirror control switches are located on the driver's door armrest.

Driver's side: Press the **L** button (a light in the switch will light up) to activate the adjustment control and then use this control to adjust the driver's door mirror.

Passenger's door: Press the **R** button (a light in the switch will light up) and then use the adjustment control to adjust the passenger's door mirror.

After you have adjusted the mirror(s), press the **L** or **R** switch again (the light will go out) to deactivate the adjustment control.



Mirrors

For information about the optional folding mirror function see page 64.



WARNING

The mirrors should always be adjusted prior to driving. Objects seen in the passenger's side wide-angle door mirror are closer than they appear to be.



CAUTION

Use the heating function to remove ice, snow, or mist from the mirrors.

Mirror memory function (with the central locking system)*

If you lock the vehicle and later unlock it with the **same** remote key and open the driver's door, the door mirrors (and the driver's seat) will automatically move to the position they were in when you left the vehicle. This feature will work in the same way with all of the remote key transmitters (up to 3) that you use with your vehicle. This feature will not function if you lock your vehicle with the key.

Water repellent glass



The side door mirrors can be treated with a water repellent coating. The symbol to the left indicates these windows have this coating.

The coating improves vision by causing the water to run off quickly.

For information on cleaning this type of glass, see page 210.



Power moonroof

Power moonroof

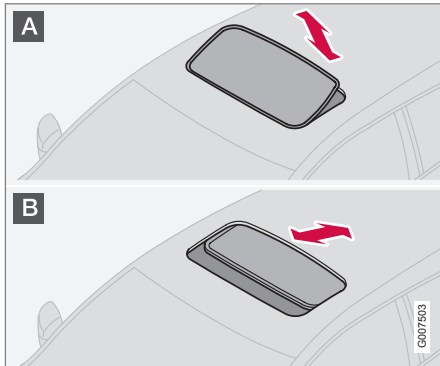

To operate the moonroof, turn the ignition key to position **I** or **II**, or start the engine. The moonroof can be operated in two ways:

- A** Tilt position
- B** Sliding moonroof

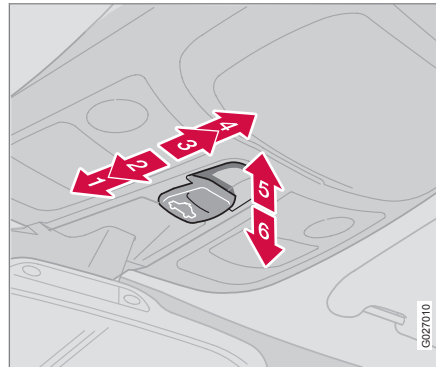

Tilt position

Open: With the moonroof closed, push up the rear edge of the switch (position 5 in the illustration in the center column).

Close: Pull down and hold the rear edge of the switch (position 6 in the illustration in the center column) until the moonroof has closed completely.

Sliding moonroof

Manual open: Pull the switch rearward to position 3 and hold it until the moonroof has opened to the position of your choice.

Auto open: Pull the switch as far back as possible (position 4) and release it to automatically slide open the moonroof to the "comfort"¹ position. Pull the switch rearward again to open the moonroof completely.

Manual close: Push the switch to position 2 and hold it until the moonroof has closed completely or to the position of your choice.

Auto close: Push the switch forward as far as possible (position 1) and release it to automatically close the moonroof.

CAUTION

- Remove ice and snow before opening the moonroof.
- Do not operate the moonroof if it is frozen closed.
- Never place heavy objects on the moonroof.

¹ A position where the moonroof is not quite fully open, which helps alleviate "rumbling" wind noise.



Power moonroof

WARNING

- Never open/close the moonroof if it is obstructed in any way when in operation.
- Never allow a child to operate the moonroof.
- Never extend any object or body part through the open moonroof, even if the vehicle's ignition is completely switched off.
- Never leave a child alone in a vehicle.

If the moonroof is obstructed during auto-close operation, it will automatically reverse direction and return to its starting position. If the moonroof is repeatedly obstructed during auto-close operation, an overload circuit breaker will temporarily halt moonroof function. The moonroof will return to normal function after a brief cool-down period.

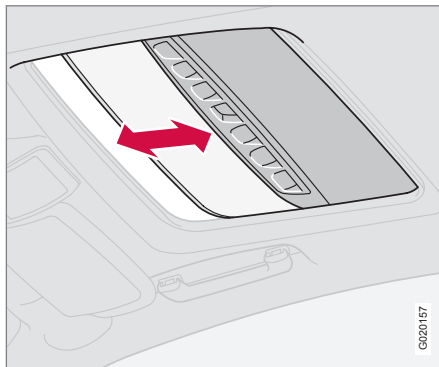

Sun visor

The optional moonroof also features a sliding sun visor. The visor slides open automatically when the moonroof is opened. The visor must be closed manually.

WARNING

The moonroof must never be obstructed in any way when in operation.



HomeLink® Wireless Control System*

Introduction

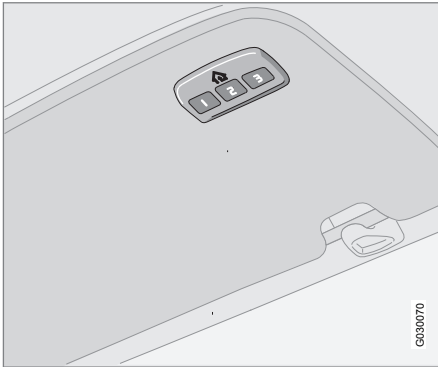

The HomeLink¹ Wireless Control System provides a convenient way to replace up to three hand-held radio-frequency (RF) transmitters used to activate devices such as gate operators, garage door openers, entry door locks, security systems, even home lighting. Additional HomeLink information can be found on the Internet at www.homelink.com or by phoning the hotline at 1-800-355-3515.

WARNING

- If you use HomeLink to open a garage door or gate, be sure no one is near the gate or door while it is in motion.
- When programming a garage door opener, it is advised to park outside of the garage.
- Do not use HomeLink with any garage door opener that lacks safety stop and reverse features as required by U.S. federal safety standards (this includes any garage door opener model manufactured before April 1, 1982). A garage door that cannot detect an object - signaling the door to stop and reverse - does not meet current U.S. federal safety standards. For more information, contact HomeLink at: www.homelink.com.

Retain the original transmitter of the RF device you are programming for use in other vehicles as well as for future HomeLink programming. It is also suggested that upon the sale of the vehicle, the programmed HomeLink buttons be erased for security purposes. Refer to “Resetting HomeLink Buttons” on page 91.

Programming HomeLink

NOTE

Some vehicles may require the ignition to be switched on or be in the “accessories” position for programming and/or operation of HomeLink. It is also recommended that a new battery be placed in the hand-held transmitter of the device being programmed to HomeLink for quicker training and accurate transmission of the radio-frequency signal. The HomeLink buttons must be reset first. When this has been completed, HomeLink is in learning mode so that you can perform programming.

1. Position the end of your hand-held transmitter 1–3 inches (5–14 cm) away from the HomeLink button you wish to program while keeping the indicator light in view.
2. Simultaneously press and hold both the chosen HomeLink and hand-held transmitter buttons until the HomeLink indicator light changes from a slow to a rapidly blinking light. Now you may release both the HomeLink and hand-held transmitter buttons.

¹ HomeLink and the HomeLink house are registered trademarks of Johnson Controls, Inc.



HomeLink® Wireless Control System*

NOTE

Some devices may require you to replace this Programming Step 2 with procedures noted in the “Gate Operator / Canadian Programming” section. If the HomeLink indicator light does not change to a rapidly blinking light after performing these steps, contact HomeLink at www.homelink.com or by phoning the hotline at 1-800-355-3515.

3. Firmly **press, hold for five seconds and release** the programmed HomeLink button up to two separate times to activate the door. If the door does not activate, press and hold the just-trained HomeLink button and observe the indicator light.
 - If the indicator light **stays on constantly, programming is complete** and your device should activate when the HomeLink button is pressed and released.
 - If the indicator light **blinks rapidly for two seconds and then turns to a constant light continue with “Programming” steps 4-6** to complete the programming of a rolling code equipped device (most commonly a garage door opener).

4. At the garage door opener receiver (motor-head unit) in the garage, locate the “learn” or “smart” button. This can usually be found where the hanging antenna wire is attached to the motor-head unit.
5. Firmly press and release the “learn” or “smart” button. (The name and color of the button may vary by manufacturer.) There are 30 seconds to initiate step 6.
6. Return to the vehicle and firmly press, hold for two seconds and release the programmed HomeLink button. Repeat the “press/hold/release” sequence a second time, and, depending on the brand of the garage door opener (or other rolling code equipped device), repeat this sequence a third time to complete the programming process.

HomeLink should now activate your rolling code equipped device.

Gate Operator/Canadian Programming
Canadian radio-frequency laws require transmitter signals to “time-out” (or quit) after several seconds of transmission – which may not be long enough for HomeLink to pick up the signal during programming. Similar to this Canadian law, some U.S. gate operators are designed to “time-out” in the same manner.

If you live in Canada or you are having difficulties programming a gate operator or garage door opener by using the “Programming” procedures, **replace “Programming HomeLink” step 2 with the following:**

- Continue to press and hold the HomeLink button while you **press and release - every two seconds** (“cycle”) your hand-held transmitter until the HomeLink indicator light changes from a slow to a rapidly blinking light. Now you may release both the HomeLink and hand-held transmitter buttons.

Proceed with “Programming” step 3 to complete.

Using HomeLink

To operate, simply press and hold the programmed HomeLink button until the trained device begins to operate (this may take several seconds). Activation will now occur for the trained device (i.e., garage door opener, gate operator, security system, entry door lock, home/office lighting, etc.). For convenience, the hand-held transmitter of the device may also be used at any time. In the event that there are still programming difficulties or questions, contact HomeLink at: www.homelink.com or by phoning the hotline at 1-800-355-3515.



HomeLink® Wireless Control System*

NOTE

If the ignition is switched off, HomeLink will function for 30 minutes after the driver's door has been opened.

Resetting HomeLink Buttons

Use the following procedure to reset (erase programming) from the three HomeLink buttons (individual buttons cannot be reset but can be “reprogrammed” as outlined in the following section):

1. Press and hold the two outer HomeLink buttons until the indicator light begins to flash.
2. Release both buttons.
 - > HomeLink is now in the training (or learning) mode and can be programmed at any time beginning with “Programming” - step 1.

Reprogramming a Single HomeLink Button

To program a device to HomeLink using a HomeLink button previously trained, follow these steps:

1. Press and hold the desired HomeLink button. **DO NOT** release the button.
2. The indicator light will begin to flash after 20 seconds. Without releasing the HomeLink button, proceed with “Programming” - step 1.

For questions or comments, contact HomeLink at: www.homelink.com or phone 1-800-355-3515.

This device complies with FCC rules part 15 and Industry Canada (IC) RSS-210. Operation is subject to the following two conditions: (1) This device may not cause harmful interference, and (2) This device must accept any interference that may be received including interference that may cause undesired operation.

NOTE

The transmitter has been tested and complies with FCC and IC rules. Changes or modifications not expressly approved by the party responsible for compliance could void the user's authority to operate the device.²

02

² The term “IC:” before the certification/registration number only signifies that Industry Canada technical specifications were met.

Climate control system – general information.....	94
Air distribution.....	96
Electronic climate control (ECC).....	98



03

CLIMATE





Climate control system – general information

Condensation on the inside of the windows

Keeping the insides of the windows clean will help reduce the amount of condensation that forms on the windows. Use a commercial window cleaning agent to clean the windows.

Ice and snow

Always keep the air intake grille at the base of the windshield free of snow.

Cabin air filter

Replace the cabin air filter with a new one at the recommended intervals. Please refer to your Warranty and Service Records Information booklet, or consult a trained and qualified Volvo service technician for these intervals. The filter should be replaced more often when driving under dirty and dusty conditions. The filter cannot be cleaned and therefore should always be replaced with a new one.

Sensors

The sunlight sensor on the dashboard and passenger compartment temperature sensor in the ECC control panel should not be covered in any way as this could cause incorrect information to be sent to the ECC system.

Parking the vehicle in warm weather

If your vehicle has been parked in the sun in warm weather, opening the windows and moonroof* for several minutes before driving will help release the warm air from the passenger compartment. When the engine is running, close the windows and moonroof and use the recirculation function for several minutes to enable the air conditioning to cool the compartment as quickly as possible.

Windows and optional moonroof

The ECC system will function best if the windows and optional moonroof are closed. If you drive with the moonroof open, we recommend that you manually adjust the temperature and blower control (the LED in the **AUTO** switch should be off).

Acceleration

The air conditioning is momentarily disengaged during full-throttle acceleration.

Climate control maintenance

Special tools and equipment are required to maintain and carry out repairs on the climate system. Work of this type should only be done by a trained and qualified Volvo service technician.

Refrigerant

Volvo cares about the environment. The air conditioning system in your vehicle contains a CFC-free refrigerant – R134a (HFC134a). This substance will not deplete the ozone layer. The approximate amount of R134a contained in the system is as follows:

6-cylinder engine

Single A/C system: 1.5 lbs (700 g)

Dual¹ A/C system: 2.2 lbs (1000 g)

The system also uses PAG oil.

¹ Includes the optional rear A/C system

* Option/accessory, for more information, see Introduction.



Climate control system – general information

Climate system blower

The climate system blower will be automatically switched off when the engine is not running (even if the ignition key is in position **I** or **II**) to avoid unnecessary battery drain. To activate the blower, turn the control to the desired setting.

The climate system blower may start automatically during a period of up to approximately 50 minutes after the ignition has been turned off to remove condensation in the A/C evaporator. It will run for 15 minutes and switch off automatically.

Passenger compartment blower

Approximately 50 minutes after the ignition is turned off, the blower may come on automatically, and run for seven minutes, to remove condensation in the A/C evaporator.

Blower function to reduce battery drain

The climate system's blower functions normally while the engine is running.

However, when the engine is switched off (even if the ignition is switched to positions **I** or **II**), the blower control will be automatically switched off to avoid unnecessary battery drain.

The following points pertain if the ignition is on but the engine is not running:

- To restart the blower, turn the control knob to the setting of your choice.
- After approximately 2 minutes, the blower speed will be reduced to avoid battery drain.

You can reset the blower speed at any time. Please be aware that the system has been designed to reduce the blower's speed again after 2 minutes, until the engine is started.

If the battery becomes drained:

- **LOW BATTERY, FAN IS REDUCED** will be displayed in the text window in the instrument panel.
- The yellow warning light in the instrument panel (see page 58) will also light up.



Air distribution

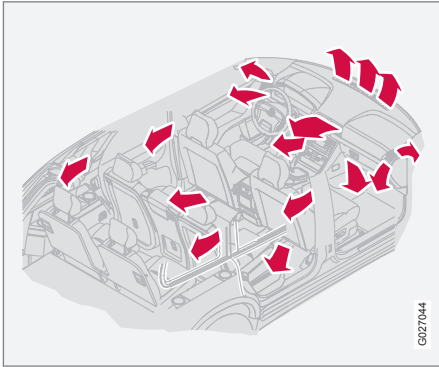

Air distribution

The incoming air is distributed through the ventilation points in the passenger compartment shown above.

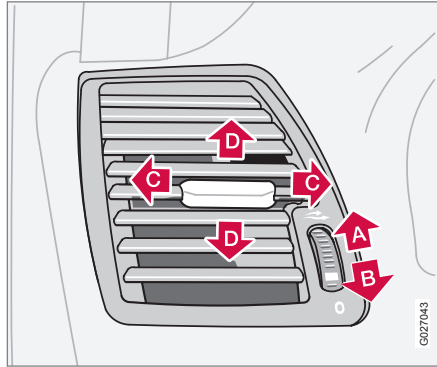

Air vents in the dash

- A** Open
- B** Closed
- C** Horizontal air flow
- D** Vertical air flow

Direct the outer air vents toward the side windows to defrost.

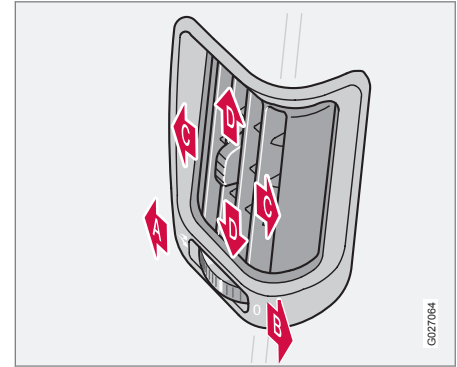

Air vents in the door pillars

- A** Open
- B** Closed
- C** Horizontal air flow
- D** Vertical air flow

Direct the outer air vents toward the side windows to defrost.

03



Ventilated front seats*

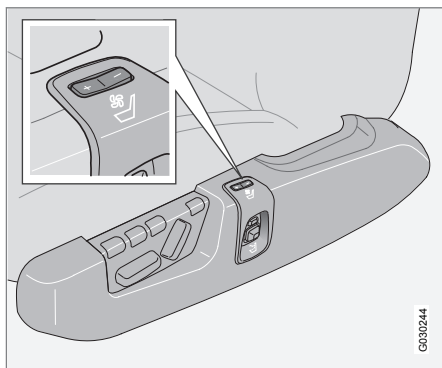

Controls for ventilated front seats

The ventilation system consists of fans in the seats and backrests that draw air through the seat upholstery. The cooling effect increases as the air in the passenger compartment becomes cooler.

The level of ventilation is adjusted on the control panel on the side of the seat. The fans can be set to three speeds.

To start seat ventilation:

- Press briefly on **+**.

To gradually increase ventilation:

- Press briefly on **+**.

For maximum ventilation:

- Hold down **+** for approximately 2 seconds.

To gradually decrease ventilation:

- Press briefly on **-**.

To switch off ventilation:

- Hold down **-** for approximately 2 seconds.

The ventilation can be used at the same time as seat heating*, for example, to help dry damp clothing.

i NOTE

- Seat ventilation cannot be started if the temperature in the passenger compartment is below 41°F (5°C).
- Seat ventilation should be used with caution by people who are sensitive to drafts. A moderate ventilation level should be set if the function is used for extended periods.

Electronic climate control (ECC)

Overview

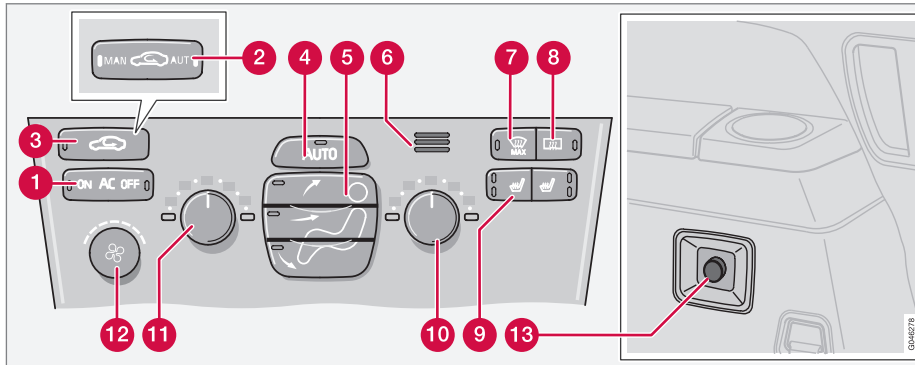

- 1** AC – (ON/OFF)
- 2** Recirculation/Multifilter with sensor*
- 3** Recirculation
- 4** **AUTO**
- 5** Air distribution
- 6** Passenger compartment temperature sensor
- 7** Defroster windshield and side windows
- 8** Rear window and door mirrors defroster
- 9** Heated front seats*

- 10** Temperature passenger's side
- 11** Temperature driver's side
- 12** Blower
- 13** Blower control for rear climate system*

Functions

- 1** **A/C – ON/OFF**
 - The air conditioning functions only at temperatures above 32°F (0°C).
 - While the Defroster function is selected, the air conditioning is temporarily activated to dehumidify the air, even if you have manually switched the air condition-

ing off. This will only function if the blower is not switched off.

Press the switch to turn the air conditioning on or off. The "ON" or "OFF" LED will light up to indicate if the system is switched on or off. Other functions will still be regulated automatically (if the **AUTO** switch is on).

- 2** **Interior air quality sensor***
Some vehicles are equipped with a multifilter and air quality sensor. The filter separates gases and particles, thereby reducing the amounts of odors and contaminants entering the vehicle. The air quality sensor detects increased levels of contaminants in the outside air. When the air quality sensor detects



Electronic climate control (ECC)

contaminated outside air, the air intake closes and the air inside the passenger compartment is recirculated, i.e. no outside air enters the vehicle. The filter also cleans recirculated passenger compartment air.

When the ECC system is in the **AUTO** mode, the green LED will be on.

3 Recirculation

Press this switch to engage the recirculation function (air in the passenger compartment recirculates – no fresh air enters the compartment). The LED in the switch will light up to indicate that the function is engaged.

- Use this function if the outside air is contaminated with exhaust gases, smoke, etc or to heat/cool the vehicle quickly.
- Recirculation should not be used for more than 15 minutes. If your windows begin to fog or mist, make sure that the recirculation function is switched off.
- Selecting **Defroster** automatically switches recirculation off.
- Timer mode activation: (Vehicles equipped with the Interior Air Quality system have no timer mode) Press and hold the recirculation button for at least 3 seconds to activate a recirculation timer mode. The amber LED in the recirculation button will flash 5 times to show that the timer mode is being activated. In timer mode,

each time the recirculation button is pressed, the climate control system will recirculate the air in the passenger compartment for 5 – 12 minutes, depending on the outside air temperature, and then revert back to fresh air.

- Timer mode deactivation: Press and hold the recirculation button for 3 seconds. The amber LED in the recirculation button will illuminate steadily for 5 seconds to show a return to "normal" mode.
- In normal mode, when the recirculation button is pressed, the climate control system will recirculate the air in the passenger compartment until the recirculation button is pressed again.
- Timer mode memory: If the vehicle is turned off while timer mode is active, timer mode will still be active when the vehicle is restarted.

4 AUTO

This function automatically regulates the Electronic Climate Control system so that the selected temperatures are maintained. The blower, heating, air distribution (air flow), air conditioning, and optional air quality sensor are controlled. If you prefer to manually set any of these functions, the remaining functions will still be controlled automatically. Pressing the **AUTO** button overrides any settings that were previously made manually.

5 Air distribution

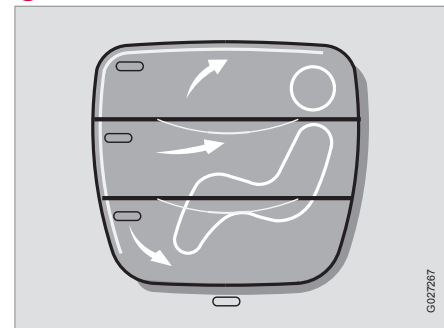

- Air flow to windows
- Air through panel vents
- Air through floor vents

Press **AUTO** to automatically regulate air flow or press any combination of the controls shown in the illustration to manually adjust air flow. An LED in the switch will light up if an air flow control has been pressed.

6 Passenger compartment temperature sensor

Measures the temperature in the compartment.

7 Defroster

This function defrosts/deices the windshield and front side windows. The LED in the



Electronic climate control (ECC)

switch will light up to indicate that the defrost function is engaged.

- Blower speed increases automatically and the air conditioning will switch on (if not already on and if the passenger compartment blower is not turned off) to dehumidify the air in the passenger compartment.
- Recirculation will not function while defrost is engaged.

The climate system will return to its previous settings when the defroster function is switched off.

8 Rear window and door mirror defrosters

This function defrosts/deices the rear window and door mirrors. The LED in the switch will light up to indicate that the heating function is engaged. For additional information on this function see page 75.

Never use ice scrapers made of metal as they can easily scratch the mirror surface.

9 Heated front seats*

1. Press the switch once for maximum seat heating. Both LEDs in the switch will be lit.

2. Press the switch a second time for comfort heating. One LED in the switch will be lit.
3. Press the switch a third time to turn the heating off completely. The LED will go off.

The seat heating for the passenger seat should be switched off when the seat is not occupied.

Heated rear seats (XC90 Executive*)

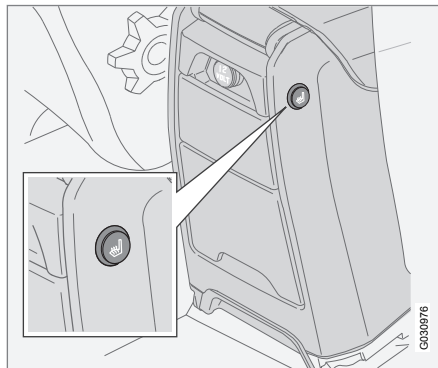

Button for rear seat heating

Heating for the respective outboard rear seats can be switched on or off with buttons

on either side of the center console (see the illustration).

To switch on rear seat heating:

- Press the button.
 - > The symbol in the button will illuminate.

To switch off rear seat heating:

- Press the button.
 - > The symbol in the button will go out.

10/11 Temperature

These controls are used to individually set the temperature for both sides of the passenger compartment. Please note that the compartment will not be heated or cooled faster by setting the temperature higher or lower than necessary.

Set the control to the temperature you prefer.

12 Blower control¹

Turn the control clockwise to increase or counterclockwise to decrease the blower speed. Pressing the **AUTO** switch will automatically regulate blower speed and override manual adjustment.

Turning the blower control counterclockwise until an orange LED comes on will turn both the blower and the air conditioning off.

¹ See also see page 94.



Electronic climate control (ECC)

Blower control for rear climate system*

Turn the control to increase or decrease blower speed.

Operation

Press to operate the air quality sensor (normal setting).

or:

Select one of the following three functions by pressing 1, 2 or 3 times.

1. The **AUT LED** lights. The air quality sensor is now activated.
2. No LED lights. Recirculation is not activated unless needed to cool the passenger compartment in a warm climate.
3. The **MAN LED** lights. Recirculation is now activated.

Keep in mind the following:

- Make it a rule to have the air quality sensor activated at all times.
- Recirculation is limited in cold climates to avoid fogging.
- If window fogging occurs, you should deactivate the air quality sensor. Also use the defroster functions for the windshield, side windows and rear window, see page 98.

- The filter should be changed at the intervals recommended in the service schedule. However, if the vehicle is used in a severely contaminated environment, it may be necessary to change the filter more frequently.

Front seats.....	104
Rear seats.....	108
Interior lighting.....	111
Storage compartments.....	114
Securing cargo.....	119



04

INTERIOR

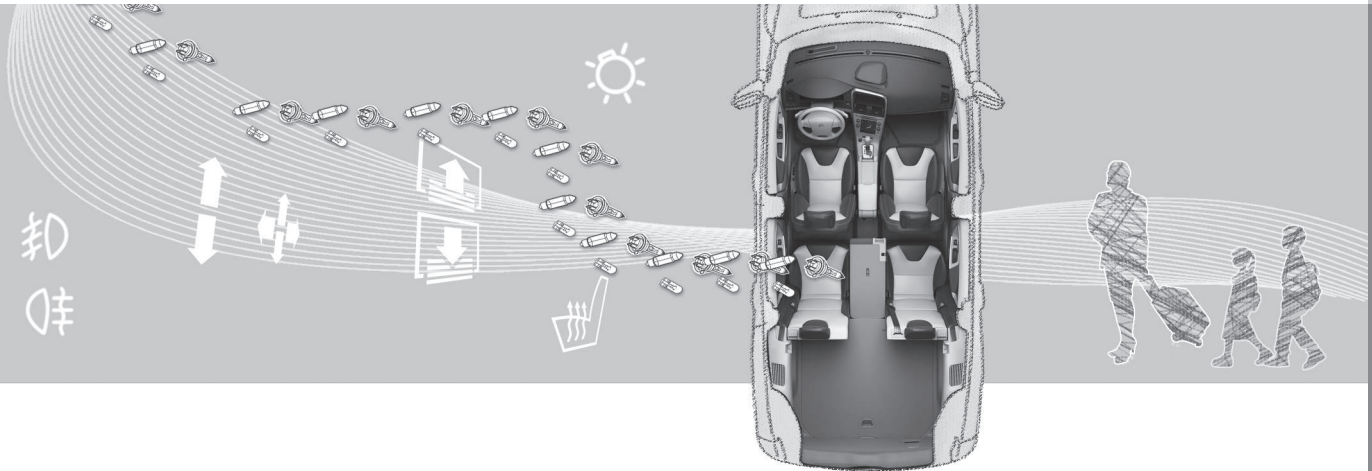



Front seats

Manually adjusted front seats



- 1 Front-rear adjustment: lift the bar and move the seat to the position of your choice.
- 2 Raise/lower the front edge of the seat cushion*: use the control to pump the front edge of the cushion up or down.
- 3 Raise/lower seat height: pump the seat up or down.
- 4 Lumbar support: turn the control for firmer or softer lumbar support.
- 5 Backrest tilt: turn the control to adjust the angle of the backrest.
- 6 Control panel for optional power seat (see page 105 for more information).

WARNING

- Do not adjust the seat while driving. The seat should be adjusted so that the brake pedal can be depressed fully. In addition, position the seat as far rearward as comfort and control allow.
- Check that the seat is securely locked into position after adjusting.

Folding the backrests in the front seat*

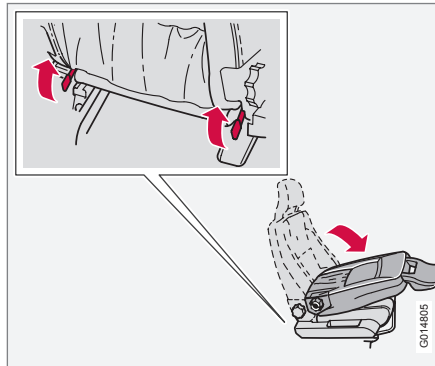

The front passenger seat backrest can be folded to a horizontal position to make room for a long load. Fold the backrest as follows:

1. Move the seat as far back as possible.
2. Adjust the backrest to the upright position.
3. Lift the catches on the rear of the backrest.
4. Without releasing the catches, push the backrest forward.
5. Move the seat as far forward as possible so that the head restraint slides under the glove compartment.

WARNING

- When transporting long objects, cover sharp edges on the load to help prevent injury to occupants. Secure the load to help prevent shifting during sudden stops.
- When the seat's backrest is returned to the upright position, push and pull it to be sure that it is securely locked in this position.



Front seats

Power seat***Operation**

Driver's seat: The seat can be adjusted if the ignition key is in position **I, II** or if the engine is running. It can also be adjusted as follows **with the ignition off:**

- Within several minutes after the driver's door has been unlocked from the outside, has been opened, and remains open.
- Within a short period if the driver's door has just been closed.
- Within a short period if the driver's door has not been opened after the ignition has been switched off.

Passenger seat: The seat can only be adjusted if the ignition key is in position **I, II** or if the engine is running.

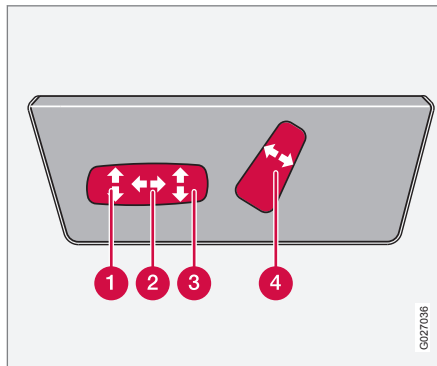

Power seat adjustment controls

Seat adjustment

Adjust the power seat(s) with the two controls at the side of the seat as follows:

- 1 Front edge of seat (raise/lower)
- 2 Forward – rearward
- 3 Rear edge of seat (raise/lower)
- 4 Backrest tilt

NOTE

The power seats have an overload protector that activates if a seat is blocked by any object. If this occurs, switch off the ignition (key in position 0) and wait for a short period before operating the seat again.

Emergency stop

If the seat accidentally begins to move, press any of the buttons to stop the seat.

NOTE

Please refer to the following page for information on programming the memory function in the driver's seat.

Remote keyless entry system and the driver's seat

The remote key transmitter also controls the position of the electrically operated driver's seat in the following way:

- Adjust the seat to your preferences.
- When you leave your vehicle, lock it using the remote key.

The position of the seat is now stored in the remote key.



Front seats

Automatic seat adjustment

To move the seat to the position in which you left it:

1. Unlock the driver's door with the same remote key (the one used to lock the doors)
2. Open the driver's door within 2 minutes.

The driver's seat will automatically move to the position in which you left it.

NOTE

- The seat will move to this position even if someone else has moved it to a different seating position and locked the vehicle with a different remote key.
- This feature will work in the same way with all of the remote key transmitters (up to 3) that you use with your vehicle.
- This feature will not function if you lock your vehicle with the key.

WARNING

- Because the driver's seat can be adjusted with the ignition off, children should never be left unattended in the vehicle.
- Movement of the seat can be STOPPED at any time by pressing any button on the power seat control panel.
- Do not adjust the seat while driving.
- The seat should be adjusted so that the brake pedal can be depressed fully. In addition, position the seat as far rearward as comfort and control allow.
- The seat rails on the floor must not be obstructed in any way when the seat is in motion.

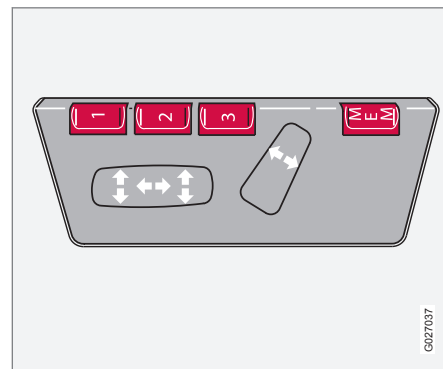

Programming the memory

Three different seating and door mirror positions can be stored in the driver seat's memory.

The following example explains how button 1 can be programmed. Buttons 2 and 3 can be programmed in the same way.

To program (store) a seat position in button 1:

1. Move the seat to the desired position using the seat adjustment controls (see page 104).
2. Press and hold down the **MEM** (memory) button.



Front seats

3. With the **MEM** button depressed, press button 1 briefly to store the seat's current position.

To move the seat to the position that it was in when button 1 was programmed:

Press and hold down button 1 until the seat stops moving.

As a safety precaution, the seat will stop automatically if the button is released before the seat has reached the preset position.

Front seats*

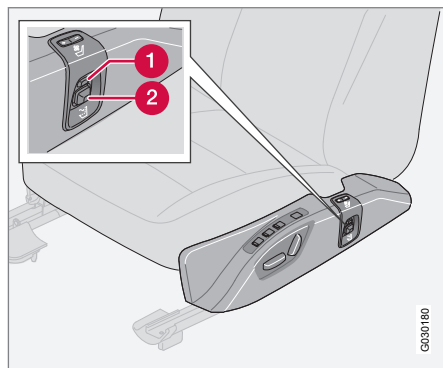

- 1 Message
- 2 Lumbar support

Message

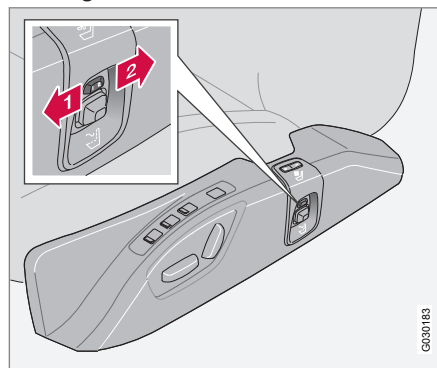

Message control

- 1 Firm message
- 2 Gentle message

Each front seat has a massage function in its backrest. The massage action is done with air cushions, which can be adjusted to a firm or gentle setting. When the setting has been made, the massaging action is carried out in cycles as follows: massage 6 minutes – pause 4 minutes – massage 6 minutes, etc.

When the button is in the center position or if the ignition is in position **0**, the massage function is switched off.

Lumbar support

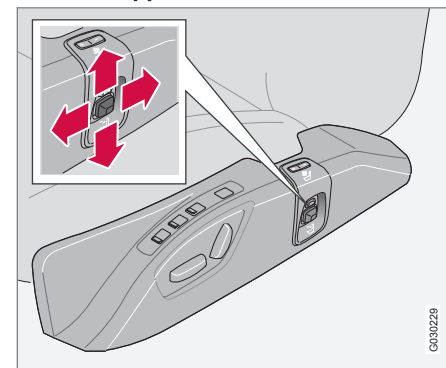

Lumbar support control

The lumbar support uses the same air cushions as the massage function. The button can be used to adjust the amount of support in four directions, as shown in the illustration.

Lumbar support can only be adjusted when the massage function is switched off.

A memory function stores the lumbar support setting and this support will resume after the massage function has been switched off or after the vehicle has been parked for an extended period of time.



Rear seats

Entering the third row of seats



Tilting the outboard backrests in the second row of seats:

- Pull up the handle (1), hold it up, and tilt the backrest forward to move the seat.
- Return the backrest to the upright position to slide the seat back to its original position.

Forward/rearward seat adjustment

Lift the adjustment bar (2) to move the seat forward or rearward.

Removing the center console¹

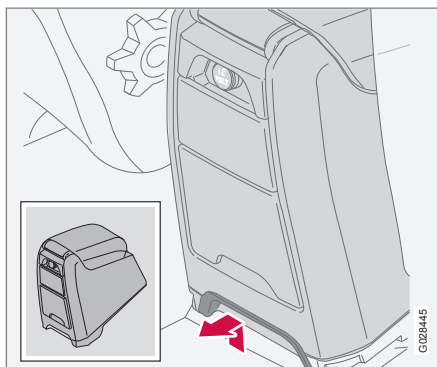

In order to make it possible to move the center seat in the second row of seats as far forward as possible (seven-seat models only), the rear section of the center console can be removed.

- Pull the handle (see illustration) and lift out the console.
- To return the console to its original position, slide it back into position until it clicks into place.



Sliding center seat – second row (seven-seat models only)

The center seat in the second row can be moved farther forward than the outboard seats. This makes it possible for a child seated in this position to sit closer to the people in the front seats.

¹ The center console cannot be removed on vehicles equipped with the optional Rear Seat Entertainment System.



Rear seats

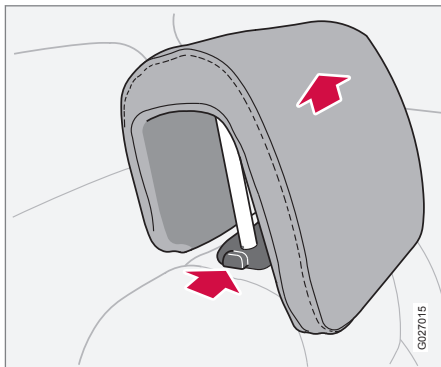

Head restraint – second row, center position

The head restraint in the center position can be adjusted to 4 different heights.

To raise – pull the restraint up until it clicks into one of the four heights positions.

To lower – press the button at the base of the support (see illustration) and press the head restraint down carefully.

WARNING

The center rear seat head restraint should only be in its lowest position when this seat is NOT occupied. When the center position is occupied, the head restraint should be correctly adjusted to the passenger's height. The upper edge of the head restraint should be at least on a level with the upper-most point of the seat occupant's ear.

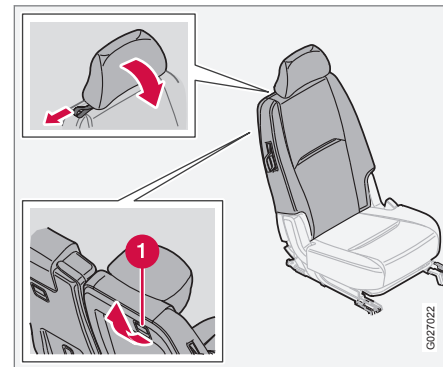
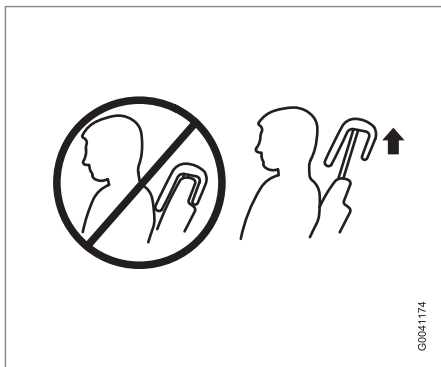

Folding the backrests – second row of seats

CAUTION

To help avoid damage to the upholstery, there should be no objects on the rear seat and the seat belt should not be buckled when the backrest is folded down.

1. Move the seat(s) to their rearmost position (seven-seat models only).
2. Pull the loop to fold down an outboard head restraint. Press down the center head restraint if necessary (see page 109).



Rear seats

3. Pull the handle (1) outward to release the backrest. The backrests are designed to lock at a 45 degree angle. Pull the handle again to continue pressing it down until it locks in the horizontal position.

To return the backrests to the upright position, pull handle 1 and pull the backrest up.

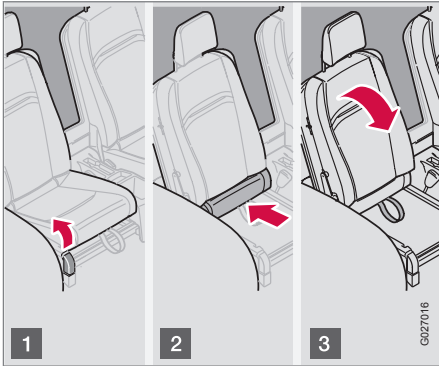

Folding the backrests—third row of seats

Folding down the backrest

If necessary, fold in the load anchorage eyelets before folding down the backrests.

1. Move the seats in the second row as far forward as possible, see page 108.
2. Pull up the handle (see illustration 1).
3. Push the seat cushion firmly rearward, under the backrest (see illustration 2).
4. Fold down the backrests² (the head restraints fold down automatically) to the horizontal position.

WARNING

The seats in the third row are not equipped with top tether anchors or ISOFIX/LATCH lower child seat anchors. Child restraint systems should never be used on these seats.

Returning the backrest to the upright position

1. Fold up the backrest to the upright position.
2. Grasp the strap (see illustration 3) and pull the seat cushion out until it locks in place. This also locks the backrest in the upright position.

WARNING

- When one or more sections of the backrest is returned to the upright position, check that it is properly locked in place by pushing and pulling it. The red indicators should also not be visible.
- Return the outboard head restraints to the upright position.
- Long loads should always be securely anchored to help avoid injury in the event of a sudden stop.
- Always turn the engine off and apply the parking brake when loading/unloading the vehicle.
- Place the transmission in the Park (P) position to help prevent inadvertent movement of the gear selector.
- On hot days, the temperature in the vehicle interior can rise very quickly. Exposure of people to these high temperatures for even a short period of time can cause heat-related injury or death. Small children are particularly at risk.

² Please note that the head restraints in this row cannot be vertically adjusted.



Interior lighting

Reading lights and courtesy light

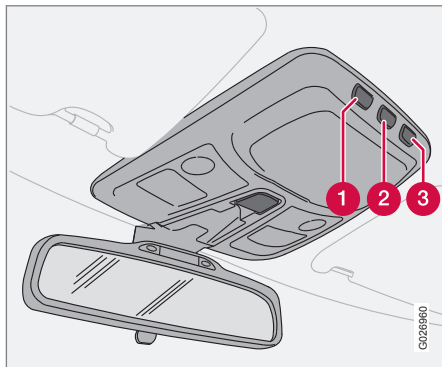

- 1 Driver's side front reading lamp
- 2 Courtesy lights
- 3 Passenger's side front reading lamp The reading lights can be switched on or off by pressing buttons 1 or 3. The courtesy lighting (including footwell lighting) can be turned on or off by pressing button 2. This also activates the automatic function.

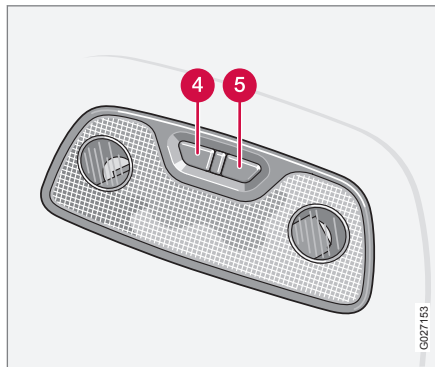

Rear reading lights

- 4 Driver's side rear reading light
- 5 Passenger's side rear reading light. The rear reading lights can be switched on and off by pressing buttons (4) or (5).

Automatic function

The reading lights and courtesy lights will switch off automatically approximately 10 minutes after the engine has been turned off. The lights can be turned off sooner by pressing the respective buttons.

The courtesy lights come on automatically¹ and remain on for approximately 30 seconds when:

- The vehicle has been unlocked from the outside with the remote key or key blade
- If the engine has been switched off and the ignition key has been turned to position 0

The courtesy lights will come on and remain on for approximately 10 minutes when:

- One of the doors is opened (assuming the courtesy lighting has not previously been switched off)

The courtesy lighting will go off when:

- The engine is started
- The vehicle is locked from the outside with the remote key or key blade

The automatic function can be disconnected by pressing button (2) for more than 3 seconds.

Briefly pressing the button again automatically reconnects the function.

The courtesy light timer periods can be changed. Contact a trained and qualified Volvo service technician.

¹ This function is light dependent and is only activated in dark conditions.



Interior lighting

Vanity mirror

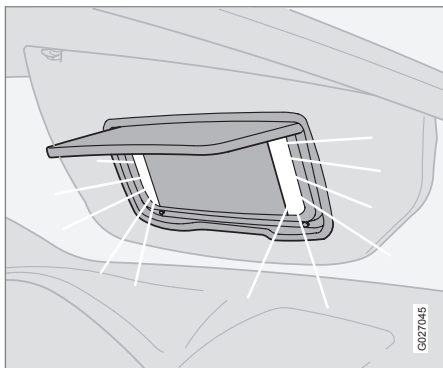

The light comes on when you open the cover.

Glove compartment lighting

The light in the glove compartment comes on or switches off when its door is opened or closed.



Interior lighting

04



Storage compartments

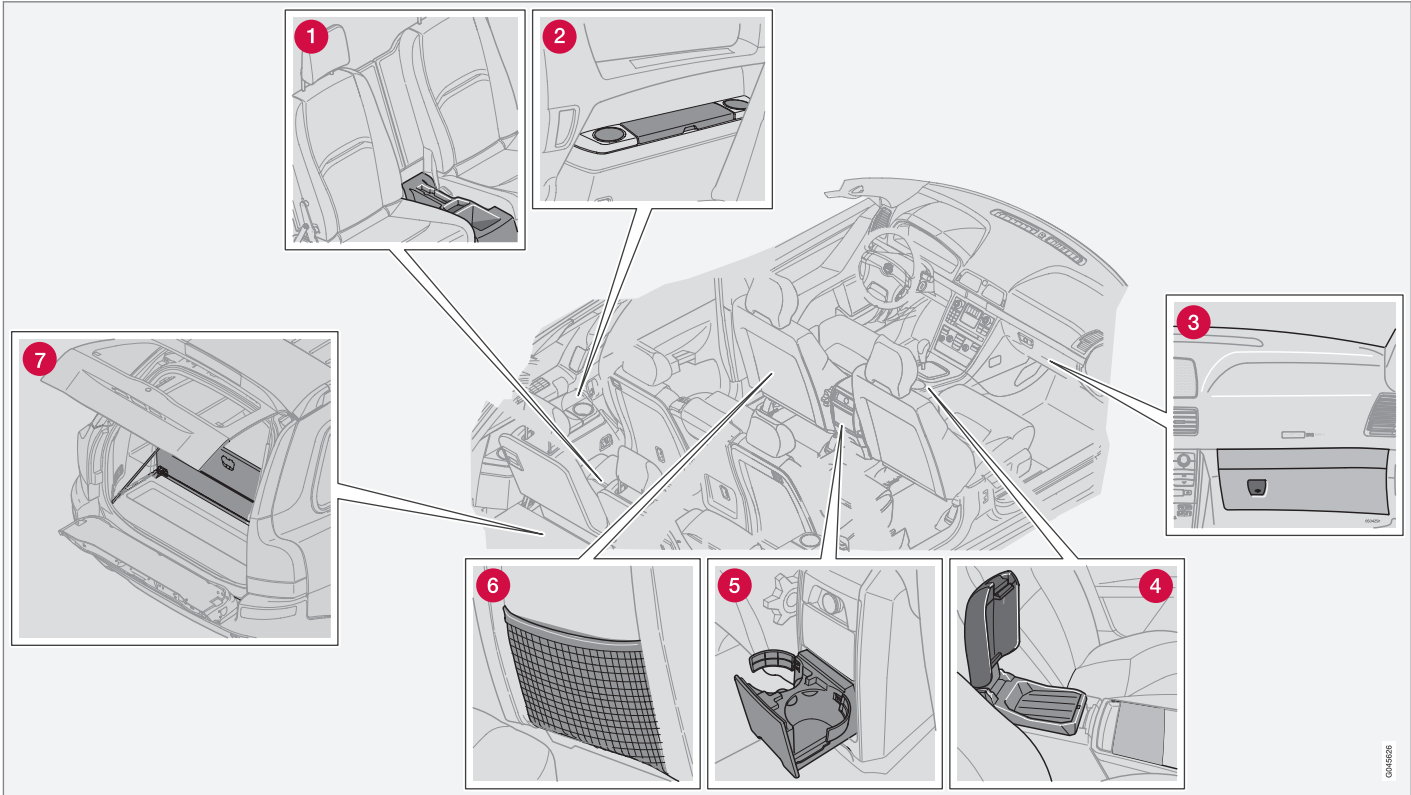

044628



Storage compartments

- 1 Storage compartment in third row of seats
- 2 Storage compartment
- 3 Glove compartment
- 4 Storage compartment in center console
- 5 Rear seat cup holders
- 6 Storage pocket (also in front edge of front seats)
- 7 Grocery bag holder*

WARNING

Make sure that no hard, sharp or heavy objects lie on or in any of the storage areas where they might cause injury during sudden braking.

Storage compartment in the center console

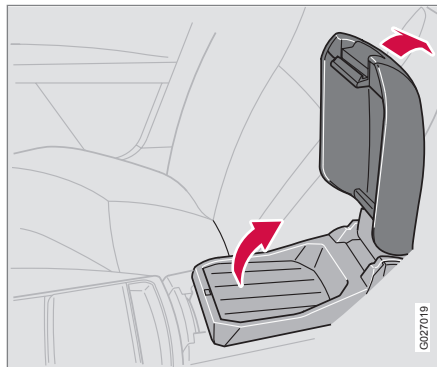

To open the lid on the storage compartment, press the lower edge of the opening latch (see illustration above). This lid can be folded back to form a small table area for rear seat passengers.

Lift the tray under the lid to expose the deep storage bin with slots for CD storage.

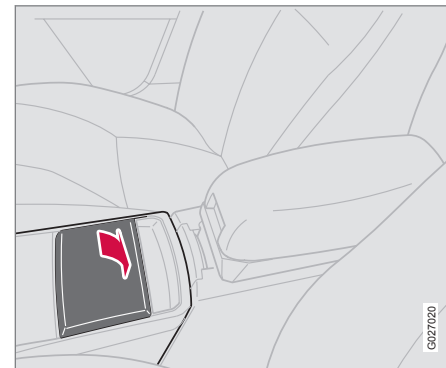

Cup holders for the front seats

Two cup holders are provided for the front seat occupants. Press lightly on the rear edge of the cover to open it.

Ashtray (accessory)

An ashtray insert is available from your Volvo retailer. This insert slides into either of the cup holders.

Pen holder

There is a pen holder in the center console, in front of the gear selector.



Storage compartments

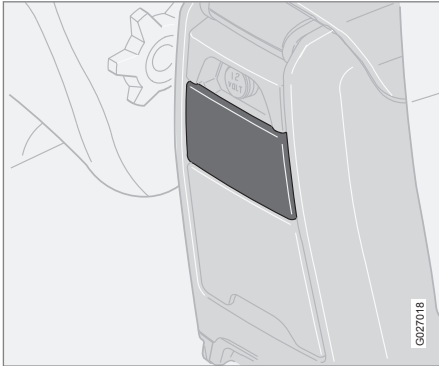

Storage compartment in rear side of the center console

Grasp the upper edge of cover and pull to open this compartment.

Ashtray (accessory)

An ashtray insert is available from your Volvo retailer.

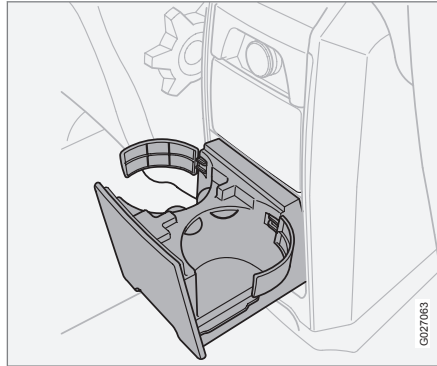

Cup holders for the rear seats

- Grasp the lower edge of the panel to pull out the cup holders in the rear side of the center console.
- The cup holder insert can be removed to provide space for a large plastic bottle. Pull the insert straight up to remove it. Press down to reinsert it.

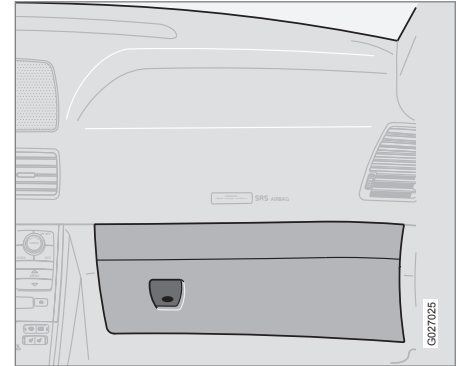

Glove compartment

The glove compartment can be used to store things such as the owner's manual, maps, pens, etc.



Storage compartments

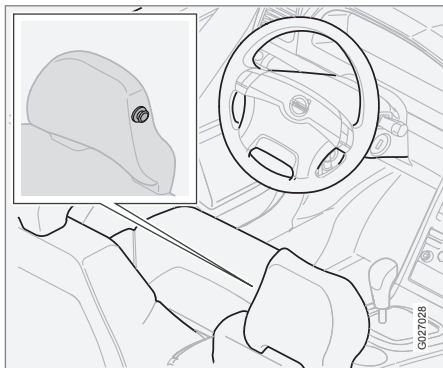

Coat hanger

The jacket hanger is located on the inboard side of the front passenger's seat head restraint. It is only intended for hanging light garments.



Storage space between rear seats

This storage space provides compartments for pens or other small items.

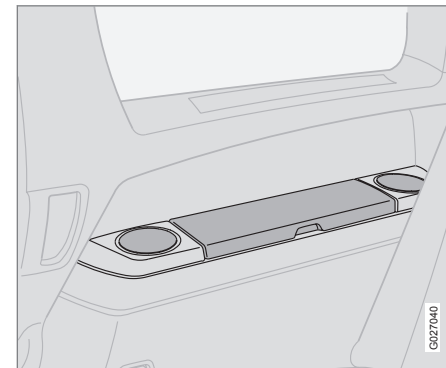

Rear side storage compartments and cup holders (seven-seat models)

Lift the lid to access the storage compartment.



Storage compartments

Refrigerator*

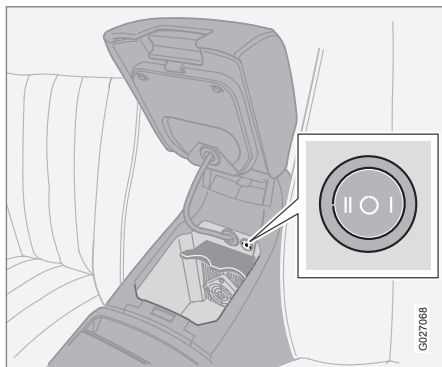

The refrigerator is located under the cover in the front seat center armrest. Use the button (see the inset illustration) to adjust the level of cooling.

The refrigerator functions when the engine is running or when the ignition is in position II.

WARNING

Bottles kept in the refrigerator should be firmly sealed and the cover over the refrigerator must be securely closed while the vehicle is in motion.



Securing cargo

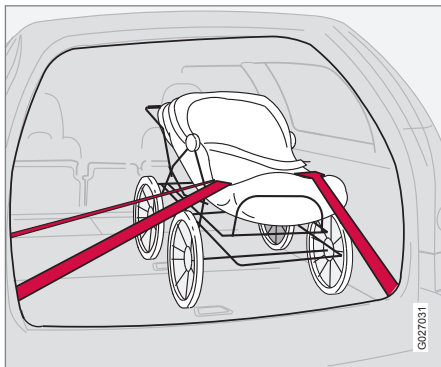

As a safety precaution, all cargo in your vehicle should be securely anchored to keep it from being thrown forward in the event of sudden braking, etc. The vehicle is equipped with eyelets in the cargo space to which straps or other cargo restraints can be attached.

WARNING

The eyelets are not to be used as passenger restraints or as anchorages for child restraints.

Consult your Volvo retailer about suitable accessories for this purpose.

Remember that an object weighing 44 lbs (20 kg) produces a force of 2,200 lbs (1,000 kg) in a head-on collision at 30 mph (50 km/h)!

Keep the following in mind when loading the vehicle:

- The load carrying capacity of your vehicle is determined by factors such as the number of passengers, the amount of cargo, the weight of any accessories that may be installed, etc. See the section "Vehicle loading" in the chapter "Wheel and tires" for more detailed information.
- Load the cargo **against** the backrest.
- Load heavy cargo as low as possible.
- If no one is sitting in the outboard rear seat(s), reinforce the backrest by fastening the seat belts.
- Never load cargo above the backrest without a cargo net.

WARNING

When the rear backrest(s) are folded down, the vehicle should not be loaded to a level higher than 2 in. (5 cm) below the upper edge of the rear side windows. Objects placed higher than this level could impede the function of the inflatable curtain.

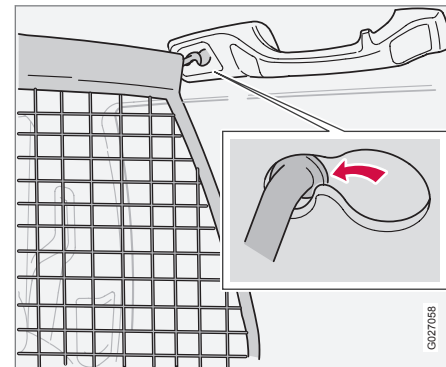

Attachment bracket

Nylon cargo net (accessory)

The Volvo XC90 can be equipped with a cargo net made of strong nylon fabric.

This net can be installed in two places:

- Behind the rear seat backrests (the second row of seats)
- Behind the front seat backrests if the rear seat backrests (the second row of seats) have been folded down.



Securing cargo

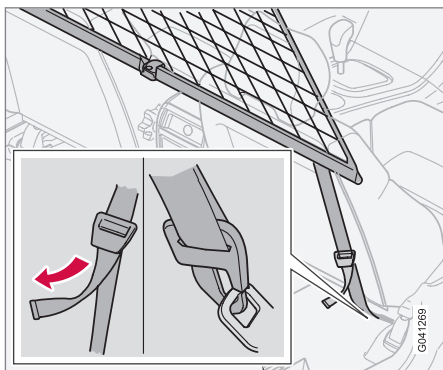

Attachment eyelet in front seat rail

If the vehicle is equipped with the cargo area cover, lift the cover out of the vehicle before installing the cargo net.

1. The upper and lower rods of the cargo net are hinged. Position the rods so that they are straight and lock in position.
2. Insert the end of the upper rod in one of the attachment brackets (see illustration in the left column).
3. Insert the other end of the rod in the attachment bracket on the opposite side of the vehicle.

i NOTE
When using the net in the rear attachment brackets, be sure it is installed in front of the side armrests.

4. Attach the lower straps to the eyelets on the floor if the net has been installed in the rear attachment brackets. Use the eyelets in the front seat rails if the net has been installed in the forward attachment brackets.
5. Adjust the straps to pull the net taut.

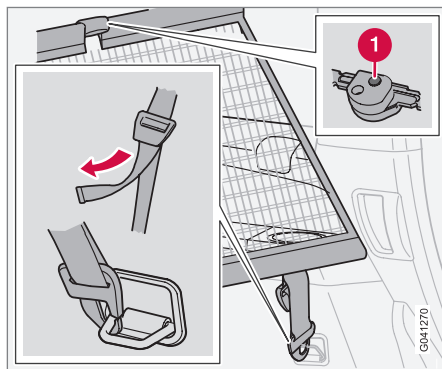

Folding and storing the cargo net
Press the release buttons on the hinges (1 in the illustration) and fold the net.

! WARNING

- Be sure the cargo net is properly inserted in the attachment brackets and the straps are correctly attached to the eyelets and pulled taut.
- Do not use the net if it is damaged in any way.
- When it is not in use, store the net so that it cannot be thrown forward in the event of sudden braking, etc.

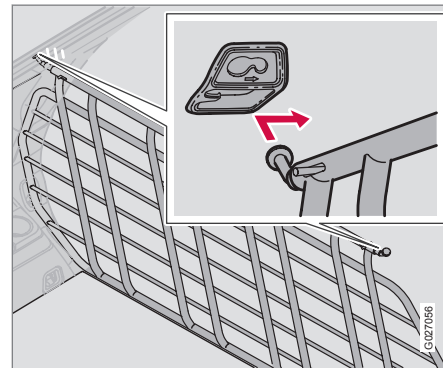

Upper attachments



Securing cargo

Steel grid (accessory)

Installing the grid, upper attachments

1. Lift in the grid through the tailgate or through one of the rear passenger doors (in this case, fold down the rear seat backrests/backrests in second row of seats in seven-seat models).
2. Insert one of the grid's upper attachments into an attachment bracket above one of the rear passenger doors (see illustration above).
3. Push the grid's attachment into the forward position in the attachment bracket (see inset illustration above) to lock the attachment in place.

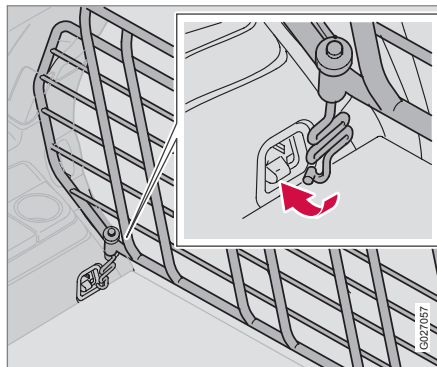

Lower attachments

4. Insert the grid's other upper attachment in the attachment bracket above the opposite rear passenger door, and press the attachment into the forward position in the attachment bracket to lock it in place.

Installing the grid, lower attachments

1. Insert the lower attachment bracket through the steel grid's lower mount from underneath.
2. Install the spring on the attachment bracket and tighten the knob.

3. Secure the attachment bracket hook in the lower cargo eyelet. Turn the knob to tension the attachment bracket in the cargo eyelet.
4. Repeat the operation on the opposite side.
5. Tighten both attachment brackets alternatively.
6. Place the protective caps on the threads above the knobs.



WARNING

- The backrests of the third row seats must be folded down when installing the steel grid.
- The steel grid is installed behind the second row of seats. To avoid the risk of injury, no one should be allowed to sit in the third row of seats when the steel grid is in place in the vehicle.



Securing cargo

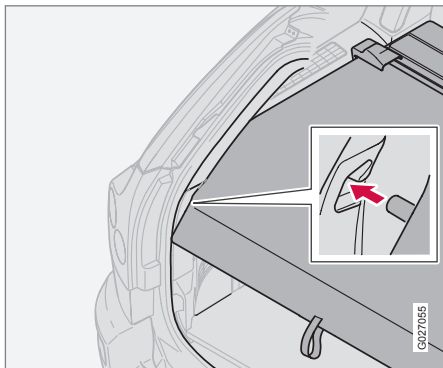

Cargo area cover*

Installing the cargo area cover:

1. Press the end pieces of the cargo area cover down in the holders.
2. Pull out the cargo area cover and hook it in the holes in the rear cargo area pillars (see illustration above).

Removing the cargo area cover:

1. Press the end pieces of the cover inward.
2. Pull up and lift out.

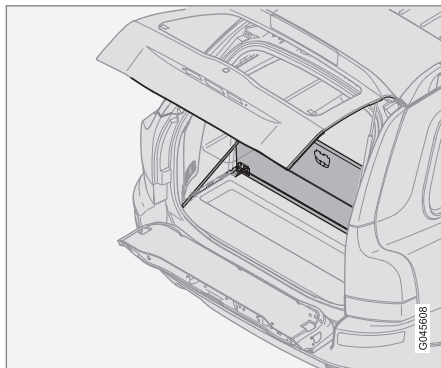

Grocery bag holder

1. Fold down the lower section of the tailgate.
2. Fold up the rear section of the cargo compartment floor.
3. Hang or secure your grocery bags by means of the straps or holders.



A long, empty rectangular box with a thin black border, spanning most of the width of the page below the header.

Remote keys and key blades.....	126
Locking and unlocking.....	130
Child safety locks.....	132
Alarm.....	133



05

LOCKS AND ALARM





Remote keys and key blades

Key blades

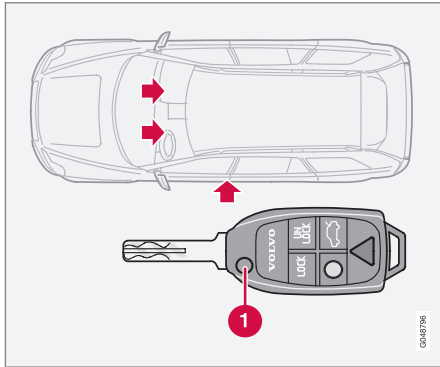

Your vehicle is equipped with two coded remote key transmitters with integrated ignition key blades called Key Integrated Remote (KIR).

To unlock/lock the vehicle using the key blade:

1. If necessary, press button (1) to fold out the key blade.
2. Insert the key blade in the driver's door lock and turn it once to unlock the **driver's door only**.
3. Turn the key blade again (within 10 seconds) to unlock all doors and the tailgate.

4. Turn the key blade once in the opposite direction to lock all doors and the tailgate.

Use the switch on the driver's door armrest to lock/unlock the vehicle from the inside.



WARNING

If the doors are locked while driving, this may hinder rapid access to the occupants of the vehicle in the event of an accident. (Also see information on "Child safety locks".)



NOTE

To help prevent accidentally locking the keys in the vehicle, the central locking system is designed to unlock the doors immediately if the key is left in the ignition switch, the vehicle is locked using the lock button on the door and the door is then closed. A sound from the lock will be audible at this time.

Please note that this function will not unlock the doors if the engine is running.

Immobilizer (start inhibitor)

Each of the keys supplied with your vehicle contains a coded transmitter. The code in the key is transmitted to an antenna in the ignition switch where it is compared to the code

stored in the start inhibitor module. The vehicle will start only with a properly coded key.

Each key has a unique code, which your Volvo retailer uses if new keys are required. A maximum of six remote keys can be programmed and used for one vehicle.

If you misplace a key, take the other keys to an authorized Volvo retailer for reprogramming as an antitheft measure.

If two of the keys to your vehicle are close together, e.g., on the same key ring, when you try to start the vehicle, this could cause interference in the immobilizer system and result in the vehicle not starting. If this should occur, remove one of the keys from the key ring before trying to start the vehicle again.



NOTE

This device complies with part 15 of the FCC rules. Operation is subject to the following condition: (1) This device may not cause harmful interference, and (2) this device must accept any interference received, including interference that may cause undesired operation.



Remote keys and key blades

Remote keys

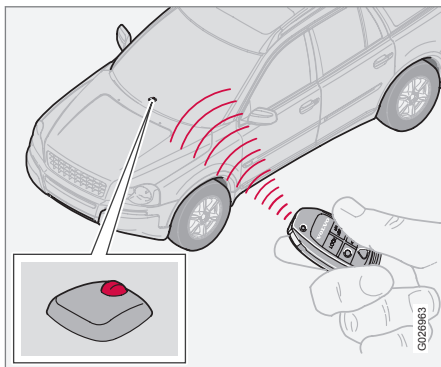

Your vehicle is equipped with two coded remote key transmitters with integrated ignition keys called Key Integrated Remote (KIR).

The remote key transmitters will also activate or allow "keyless" entry into the passenger compartment or the tailgate. These transmitters use a radio frequency that will enable you to lock/unlock all doors and the tailgate from a distance of 10 – 15 feet (3 – 5 meters). They will also activate or deactivate your vehicle's alarm system(s). The vehicle can also be locked/unlocked with the key.

If either of the remote keys is lost, the other should be taken with the car to a Volvo

retailer. As an anti-theft measure, the code of the lost remote key must be erased from the system.

i NOTE

Additional or duplicate remote control keys can be obtained from any Authorized Volvo Retailer.

You can also obtain additional or duplicate remote control keys from certain independent repair facilities and locksmiths that are qualified to make remote control keys. Each key must be programmed to work with your vehicle.

California Only:

A list of independent repair facilities and/or locksmiths known to Volvo that can cut and code replacement keys can be found:

- on the Volvo website at <http://www.volvocars.com/us/keys>
- by calling Volvo Customer Care at 1-800-458-1552

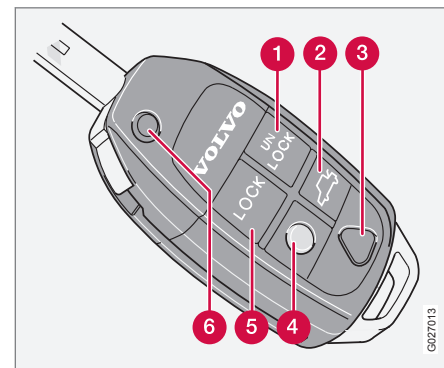

- 1 Unlock
- 2 Unlock tailgate
- 3 "Panic" function
- 4 Approach lighting
- 5 Lock
- 6 Fold key blade in/out

Using the remote key

1 Unlock

Press this button once to unlock the driver's door only. Wait for at least 1 second and



Remote keys and key blades

press the button again (within 10 seconds) to unlock all doors, and the tailgate.

2 Tailgate unlock

Press this button to unlock the tailgate (without unlocking the other doors). This function will not open the tailgate.

3 Panic function

For more information on this function, see page 133.

4 Approach lighting

Press this button when approaching the vehicle at night to light up the interior courtesy light, parking lights, license plate lights and the lights in the door mirrors.

5 Lock

Press once to lock all doors, and the tailgate.

6 Fold key blade in/out

Press to extend the key blade. This button must also be pressed when the key blade is folded back into the slot in the side of the remote key unit.

NOTE

- If an airbag deploys, your vehicle's SRS control module will attempt to automatically unlock all doors.
- The key blade may also be used to lock and unlock the doors, and to activate and deactivate the alarm system.
- To avoid leaving your keys in the vehicle, make a habit of always locking the vehicle with the remote key.
- If the key blade section of the remote is not fully folded out when starting the vehicle, the immobilizer function may make it impossible to start the engine.
- The vehicle can be locked even if a door is open. When the door(s) are closed, they will be locked. Please be aware that the keys could be locked in the car when this is done.

Automatic re-locking

If the doors are unlocked, the locks will automatically reengage (re-lock) and the alarm will rearm after 2 minutes unless a door or the tailgate has been opened. This helps prevent the car from inadvertently being left unlocked.

FCC ID: LQNP2T-APU

This device complies with part 15 of the FCC rules. Operation is subject to the following

conditions: (1) This device may not cause harmful interference, and (2) this device must accept any interference received, including interference that may cause undesired operation.

Canadian 2306104388

Model 504 2927 by Donnelly

Operation is subject to the following conditions: (1) this device may not cause interference, and (2) this device must accept any interference, including interference that may cause undesired operation of the device.

Canadian 2306104388A

Model 509 977 by Connaught Electronics

Operation is subject to the following conditions: (1) this device may not cause interference, and (2) this device must accept any interference, including interference that may cause undesired operation of the device.



Remote keys and key blades

WARNING

Never use the transmitter to lock the doors from inside the vehicle.

- Doing so would **ACTIVATE**:
 - the break-in alarm, which would sound if one of the doors were opened
 - the optional interior motion and inclination alarm sensors.
- Doing so would **DEACTIVATE**:
 - the moonroof and interior courtesy light controls.
- the central locking buttons on the front door armrests, although the interior door handles would still function to allow occupants to leave the vehicle.
- Disabled features would remain disabled until the remote is used again to unlock the vehicle.
- In addition, locking an occupied vehicle would hinder rapid access to the occupants in an accident or emergency.

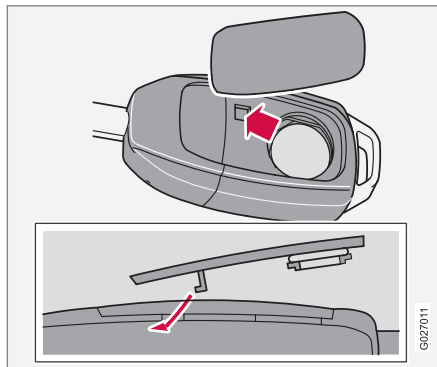
**Replacing the battery in the remote key**

If the range of the transmitter is noticeably reduced, this indicates that the battery is weak and should be replaced.

To replace the battery:

1. Carefully pry open the rear edge of the cover with a small screwdriver.
2. Insert a new 3-volt, CR2032 battery, with the battery's plus side up. Avoid touching the contact surfaces of the battery with your fingers.
3. Press the cover back into place. Ensure that the rubber seal is correctly positioned to help keep out moisture.

NOTE

The old battery should be disposed of properly at a recycling center or at your Volvo retailer.



Locking and unlocking

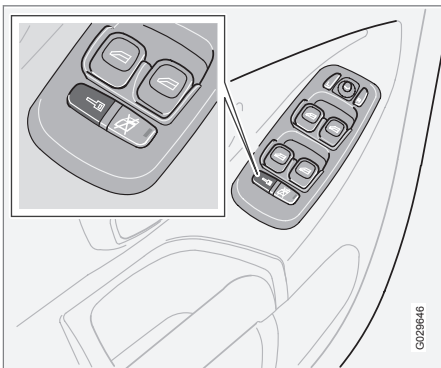

2. Press the lock section of the button.
3. Close the door. This will lock the vehicle completely and arm the alarm.

i NOTE

Please be aware that locking the vehicle in this way makes it possible to lock the remote key in the passenger compartment. To help avoid this, lock the vehicle from the outside by pressing the lock button on the remote key.

If the vehicle is locked using the central locking button, be sure that the remote key is in your possession before closing the door.

Locking and unlocking the vehicle from the inside

The switch on the driver's door armrest can be used to lock or unlock all doors and the tailgate, and to set the alarm.

Each door can also be locked with the lock button on the respective door and opened by pulling the door handle on the door.

Alternative locking when parking

The central locking button on the driver's door can also be used to lock the vehicle when you leave it. To do so:

1. Open the door.

Automatic locking

The function locks the doors automatically when the vehicle's speed exceeds approximately 5 mph (7 km/h). The doors will then remain locked until a door is opened from the inside or if all of the doors are unlocked from the control panel in the driver's door.

This function can be activated/deactivated from the control panel in the driver's door.

Activating/deactivating automatic locking

1. Turn the ignition key to position I or II.

2. Press the **READ** button on the left-side steering wheel lever to erase any messages that may be displayed in the information display.
3. Depress the central locking button on the control panel until a new message about the locking status is displayed.

The message **AUTOLOCK ON** (the doors will be locked when the vehicle begins to move) or **AUTOLOCK OFF** will be displayed.

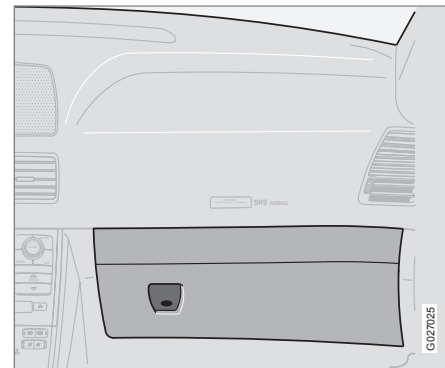

Locking the glove compartment

The glove compartment can be locked with the master key.

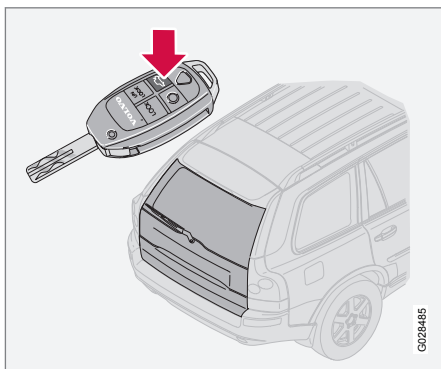

Locking and unlocking

**Automatic relocking**

If you use the tailgate unlock button to unlock the tailgate without opening it, it will automatically relock after approximately 2 minutes.

NOTE

If you open the tailgate and close it again, it will remain unlocked and the alarm will not be rearmed. Press the lock button on the remote key to relock the tailgate and rearm the alarm.

Unlocking the tailgate

The tailgate lock is incorporated in the central locking system and is locked or unlocked when all doors are locked/unlocked.

The tailgate can be unlocked by:

- Pressing **UNLOCK** on the remote key twice.
- Using the central locking button on the driver's door.
- Pressing the remote key's tailgate unlock button (see the illustration).
- Relock the tailgate using the remote's **LOCK** button.



Child safety locks

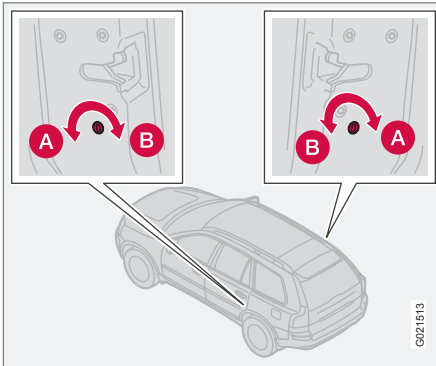

Child safety locks in the rear doors - driver's side and passenger's side respectively

Manual child safety locks – rear doors

The controls are located on the rear door jambs. Use a key or small screwdriver to adjust these controls.

- A** Turn outward: the door cannot be opened from the inside. The door can be opened from the outside.
- B** Turn inward: the door locks function normally (the door can be opened from the inside).

WARNING

Remember, in the event of an accident, the rear seat passengers cannot open the doors from the inside with the buttons in position A.

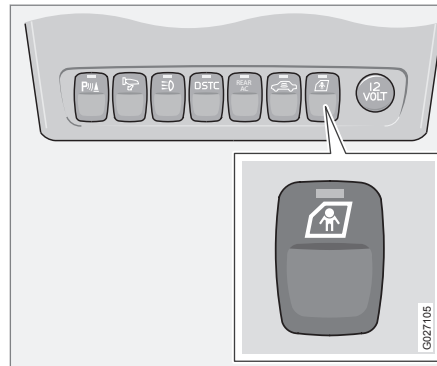

Indicator light in the button ON: the rear doors and windows cannot be opened from the inside.

Indicator light in the button OFF: the rear doors can be opened from the inside and the windows can be opened.

A message will appear in the instrument panel display when the child safety locks are activated/deactivated.

Power child locks*

To prevent the rear doors from being opened from the inside:

1. Turn the vehicle's ignition key to at least position **I** or **II**.
2. Press the button in the center console (see the illustration).

* Option/accessory, for more information, see Introduction.

**Alarm**

The alarm is automatically armed whenever you lock your vehicle.

When armed, the alarm continuously monitors a number of points on the vehicle. The following conditions will set off the alarm:

- The hood is forced open.
- The tailgate is forced open.
- A door is forced open.
- The ignition switch is tampered with.
- If there is movement in the passenger compartment (if the vehicle is equipped with the optional movement sensor).
- The vehicle is lifted or towed (if the vehicle is equipped with the optional inclination sensor).
- The battery is disconnected (while the alarm is armed).
- The siren is disconnected when the alarm is disarmed.

Arming the alarm

1. Press the **LOCK** button on the remote key.
2. Lock the vehicle using the key blade in the driver's door or press the central lock button on the driver's door with the door open.

One long flash of the turn signals will confirm that the alarm is armed.

Movement sensor*

In addition to triggering the alarm if there is movement in the passenger compartment, currents of air may also affect the movement sensor. This means that locking the vehicle with the windows or the moonroof open, or using an accessory portable passenger compartment heater, could trigger the alarm.

To help avoid this, close the windows and moonroof before locking the vehicle. If a passenger compartment heater is used when the vehicle is locked, direct airflow from the heater's vent(s) so that it isn't directed upward in the passenger compartment.

Disarming the alarm

Press the **UNLOCK** button on the remote key or unlock the doors with the key blade.

Turning off (stopping) the alarm

If the alarm is sounding, it can be stopped by pressing the **UNLOCK** button on the remote key or by unlocking the driver's door with the key blade.

Visual alarm signal

The visual alarm signal is given by flashing all turn signals and turning on the interior lighting for approximately 5 minutes.

Audible alarm signal

An audible alarm signal is given by a battery powered siren. One alarm cycle lasts for 25 seconds.

"Panic" button

In an emergency situation, this feature can be used to attract attention.

Activate the "panic" button by pressing the red button on the remote key (see page 127 for illustration) for at least 3 seconds or by pressing this button twice within 3 seconds. The turn signals will flash, and the vehicle's horn will sound.

The function can be turned off by pressing any of the buttons on the remote key or will stop automatically after 25 seconds. When a button is pressed, there is a 5 second delay before the panic alarm is deactivated.

**NOTE**

This button will NOT unlock the vehicle.

LED alarm status signals

The status of the alarm system is indicated by the red LED at the top of the dash:

- LED off – the alarm is not armed
- LED flashes once per second – the alarm is armed



Alarm

- LED flashes rapidly before the ignition is switched on – the alarm has been triggered
- **Fault in the alarm system:** If a fault has been detected in the alarm system, a message will be displayed in the text window. Contact a trained and qualified Volvo service technician.

Automatic re-lock/re-arm system

If the vehicle is unlocked with the remote, the vehicle will re-lock and the alarm will re-arm after 2 minutes unless a door or the tailgate has been opened.



[Empty rectangular box]

General information.....	138
Fuel requirements.....	139
Refueling.....	141
Starting the vehicle.....	143
Ignition switch and steering wheel lock.....	145
Economical driving.....	146
Difficult driving conditions.....	147
Automatic transmission.....	149
Jump starting.....	152
All Wheel Drive*.....	153
Brake system.....	154
Parking brake.....	157
Stability system.....	158
Front/rear park assist*.....	160
Towing.....	162
Towing a trailer.....	164
Detachable trailer hitch.....	167
Load carriers (accessory).....	168
Cold weather precautions.....	169
Before a long distance trip.....	170
Blind Spot Information System*.....	171



06

STARTING AND DRIVING

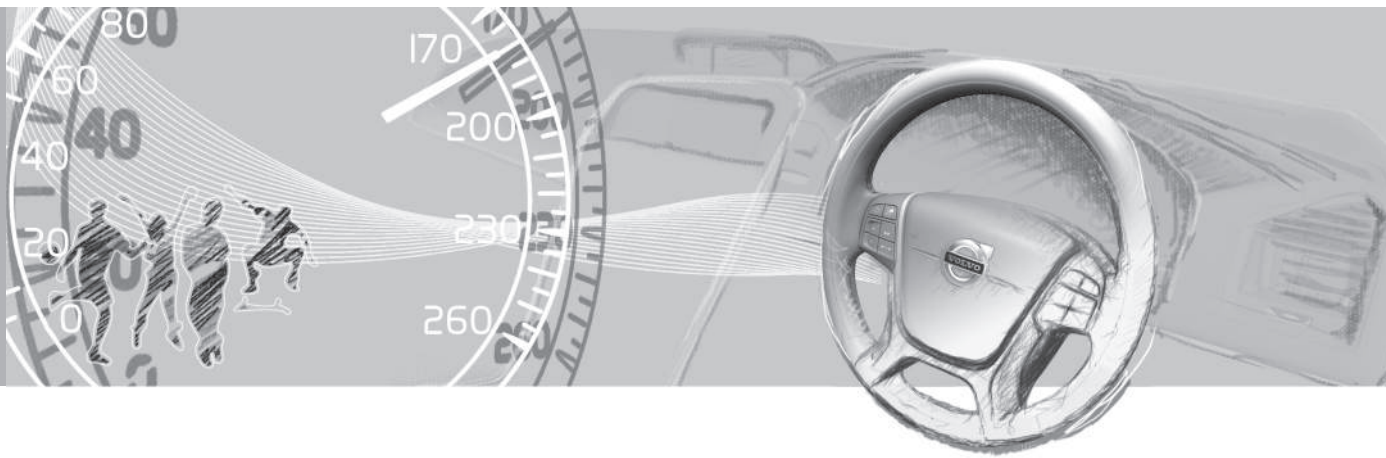



General information

Engine oil

Although some oil consumption occurs during normal engine operation, more oil is consumed when the engine is new as the internal parts generate higher friction while wearing-in to each other. From the time the engine is new until the first maintenance is performed, the oil consumption could be higher than normal. For this reason, it is especially important to check the oil regularly during this period, see page 222.

Fuel requirements

Deposit control gasoline (detergent additives)

Volvo recommends the use of detergent gasoline to control engine deposits. Detergent gasoline is effective in keeping injectors and intake valves clean. Consistent use of deposit control gasolines will help ensure good drivability and fuel economy. If you are not sure whether the gasoline contains deposit control additives, check with the service station operator.

NOTE

Volvo does not recommend the use of external fuel injector cleaning systems.

Unleaded fuel

Each Volvo has a three-way catalytic converter and must use only unleaded gasoline. U.S. and Canadian regulations require that pumps delivering unleaded gasoline be labeled "UNLEADED". Only these pumps have nozzles which fit your vehicle's filler inlet. It is unlawful to dispense leaded fuel into a vehicle labeled "unleaded gasoline only". Leaded gasoline damages the three-way catalytic converter and the heated oxygen sensor system. Repeated use of leaded gasoline will lessen the effectiveness of the emission control system and could result in loss of emission warranty coverage. State and local vehicle inspection programs will make detection of misfueling easier, possibly resulting in emission test failure for misfueled vehicles.

NOTE

Some U.S. and Canadian gasolines contain an octane enhancing additive called methyl-cyclopentadienyl manganese tricarbonyl (MMT). If such fuels are used, your Emission Control System performance may be affected, and the Check Engine Light (malfunction indicator lamp) located on your instrument panel may light. If this occurs, please return your vehicle to a trained and qualified Volvo service technician for maintenance.

Gasoline containing alcohol and ethers "Oxygenated fuels"

Some fuel suppliers sell gasoline containing "oxygenates" which are usually alcohols or ethers. In some areas, state or local laws require that the service pump be marked indicating use of alcohols or ethers. However, there are areas in which the pumps are unmarked. If you are not sure whether there is alcohol or ethers in the gasoline you buy, check with the service station operator. To meet seasonal air quality standards, some areas require the use of "oxygenated" fuel.

Volvo allows the use of the following "oxygenated" fuels; however, the octane ratings listed on page 139 must still be met.

Alcohol – Ethanol: Fuels containing up to 10% ethanol by volume may be used. Ethanol may also be referred to as Ethyl alcohol, or "Gasohol".

Ethers – MTBE: Fuels containing up to 15% MTBE may be used.

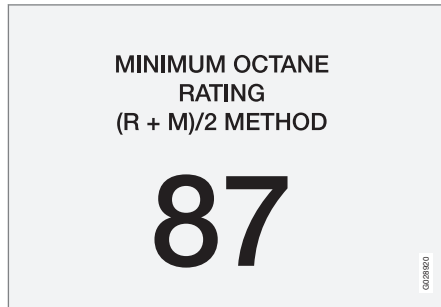

Fuel requirements

Octane rating**Minimum octane***Typical pump octane label*

Volvo recommends premium for best performance, but using 87 octane¹ or above will not affect engine reliability.

Demanding driving

In demanding driving conditions, such as operating the vehicle in hot weather, towing a trailer, or driving for extended periods at higher altitudes than normal, it may be advisable to switch to higher octane fuel (91 or higher) or to change gasoline brands to fully utilize your engine's capacity, and for the smoothest possible operation.

i NOTE

When switching to higher octane fuel or changing gasoline brands, it may be necessary to fill the tank more than once before a difference in engine operation is noticeable.

Fuel Formulations

Do not use gasoline that contains lead as a knock inhibitor, and do not use lead additives. Besides damaging the exhaust emission control systems on your vehicle, lead has been strongly linked to certain forms of cancer.

Many fuels contain benzene as a solvent. Unburned benzene has been strongly linked to certain forms of cancer. If you live in an area where you must fill your own gas tank, take precautions. These may include:

- standing upwind away from the filler nozzle while refueling
- refueling only at gas stations with vapor recovery systems that fully seal the mouth of the filler neck during refueling
- wearing neoprene gloves while handling a fuel filler nozzle.

Use of Additives

With the exception of gas line antifreeze during winter months, do not add solvents, thickeners, or other store-bought additives to your vehicle's fuel, cooling, or lubricating systems. Overuse may damage your engine, and some of these additives contain organically volatile chemicals. Do not needlessly expose yourself to these chemicals.

! WARNING

Carbon monoxide is a poisonous, colorless, and odorless gas. It is present in all exhaust gases. If you ever smell exhaust fumes inside the vehicle, make sure the passenger compartment is ventilated, and immediately return the vehicle to a trained and qualified Volvo service technician for correction.

¹ AKI (ANTI KNOCK INDEX) is an average of the Research Octane Number (RON) and the Motor Octane Number (MON), $MON+RON/2$.



Fuel requirements

WARNING

Driving with the tailgate open: Driving with the tailgate open could lead to poisonous exhaust gases entering the passenger compartment.

- If the tailgate must be kept open for any reason, proceed as follows:
- Close the windows
- Set the ventilation system control to air flow to floor, windshield and side windows and blower control to its highest setting.

Gasoline containing alcohol and ethers, "Oxygenated fuels"

Some fuel suppliers sell gasoline containing "oxygenates" which are usually alcohols or ethers. In some areas, state or local laws require that the service pump be marked indicating use of alcohols or ethers. However, there are areas in which the pumps are unmarked. If you are not sure whether there is alcohol or ethers in the gasoline you buy, check with the service station operator. To meet seasonal air quality standards, some areas require the use of "oxygenated" fuel.

Volvo allows the use of the following "oxygenated" fuels; however, the octane ratings listed on page 139 must still be met.

Alcohol – Ethanol

Fuels containing up to 10% ethanol by volume may be used. Ethanol may also be referred to as Ethyl alcohol, or "Gasohol".

Ethers – MTBE: Fuels containing up to 15% MTBE may be used.

Methanol

Do not use gasolines containing methanol (methyl alcohol, wood alcohol). This practice can result in vehicle performance deterioration and can damage critical parts in the fuel system. Such damage may not be covered under the New Vehicle Limited Warranty.

Weight distribution affects handling

At the specified curb weight your vehicle has a tendency to understeer, which means that the steering wheel has to be turned more than might seem appropriate for the curvature of a bend.

This ensures good stability and reduces the risk of rear wheel skid. Remember that these properties can alter with the vehicle load.

The heavier the load in the cargo area, the less the tendency to understeer.

Handling, roadholding

Vehicle load, tire design and inflation pressure all affect vehicle handling. Therefore, check that the tires are inflated to the recom-

mended pressure according to the vehicle load. See "Tire pressure" section.

Loads should be distributed so that capacity weight or maximum permissible axle loads are not exceeded.

Conserving electrical current

Keep the following in mind to help minimize battery drain:

- When the engine is not running, avoid turning the ignition key to position II (see page 145). Many electrical systems (the audio system, the optional infotainment/navigation systems, power windows, etc) will function with the ignition key in position I. This position reduces drain on the battery.
- Please keep in mind that using systems, accessories, etc that consume a great deal of current when the engine is not running could result in the battery being completely drained. Driving or having the engine running for approximately 15 minutes will help keep the battery charged.

NOTE

A warning message will be displayed in the text window in the instrument panel when the battery charge is low.



Refueling

Fuel filler door

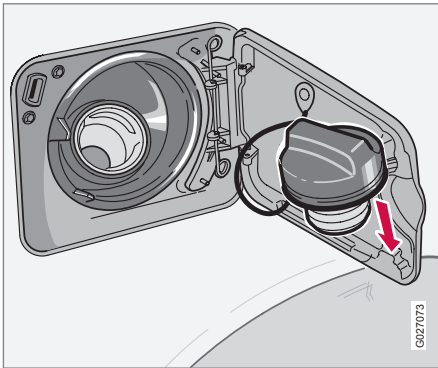

The fuel filler cap can be placed on the hook on the fuel filler door while refueling

Press the button on the light switch panel (see the illustration on page 67) when the vehicle is at a standstill to unlock the fuel filler door. Please note that the fuel filler door will remain unlocked until the vehicle begins to move forward. An audible click will be heard when the fuel filler door relocks.

If you intend to leave your vehicle while it is being refueled, this feature enables you to lock the doors/tailgate while leaving the fuel filler door unlocked.

You can also keep the vehicle locked if you remain inside it during refueling. The central locking button does not lock the fuel filler door. Be sure the fuel filler door is not obstructed and is completely closed after refueling.

Open the fuel filler cap slowly during hot weather.

i NOTE

During a transitional period, a small number of service stations may still have fuel nozzles that are not compatible with the fuel filler neck on vehicles equipped with the evaporative control system.

Refueling

The fuel tank is designed to accommodate possible expansion of the fuel in hot weather. See page 288 for fuel tank volume. Be aware that the "usable" tank capacity will be somewhat less than the specified maximum. When the fuel level is low, such factors as ambient temperature, the fuel's "Reid vapor pressure" characteristics, and terrain can affect the fuel pump's ability to supply the engine with an adequate supply of fuel. Therefore, it is advisable to refuel as soon as possible when the

needle nears the red zone, or when the fuel warning light comes on.

! WARNING

Never carry a cell phone that is switched on while refueling your vehicle. If the phone rings, this may cause a spark that could ignite gasoline fumes, resulting in fire and injury.



Refueling

CAUTION

- Do not refuel with the engine running¹. Turn the ignition off or to position I. If the ignition is on, an incorrect reading could occur in the fuel gauge.
- After refueling, close the fuel filler cap by turning it clockwise until it clicks into place¹.
- Avoid overfilling the fuel tank. Do not press the handle on the filler nozzle more than one extra time. Too much fuel in the tank in hot weather conditions can cause the fuel to overflow. Overfilling could also cause damage to the emission control systems.
- Avoid spilling gasoline during refueling. In addition to causing damage to the environment, gasolines containing alcohol can cause damage to painted surfaces, which may not be covered under the New Vehicle Limited Warranty.
- Do not use gasolines containing methanol (methyl alcohol, wood alcohol). This practice can result in vehicle performance deterioration and can damage critical parts in the fuel system. Such damage may not be covered

under the New Vehicle Limited Warranty.

¹ If the fuel filler cap is not closed tightly or if the engine is running when the vehicle is refueled, the Check Engine Light (malfunction indicator lamp) may indicate a fault. However, your vehicle's performance will not be affected. Use only Volvo original or approved fuel filler caps.



Starting the vehicle

Starting the engine

WARNING

Before starting, check that the seat, steering wheel and mirrors are adjusted properly. Make sure the brake pedal can be depressed completely. Adjust the seat if necessary, see page 104.

1. Fasten the seat belt.
2. Apply the parking brake (hand brake) if not already set. The gear selector is locked in the **P** position (SHIFTLOCK).
3. Without touching the accelerator pedal, turn the ignition key¹ to the starting position. Allow the starter to operate for up to 10 seconds. Release the key as soon as the engine starts². If the engine fails to start, repeat this step.

CAUTION

If the engine does not start after the third try, wait for approximately 3 minutes before trying to start it again to give the battery time to recover its starting capacity.

WARNING

- Never use more than one floor mat at a time on the driver's floor. An extra mat on the driver's floor can cause the accelerator and/or brake pedal to catch. Check that the movement of these pedals is not impeded.
- Volvo's floor mats are specially manufactured for your car. They must be firmly secured in the clips on the floor so that they cannot slide and become trapped under the pedals on the driver's side.

NOTE

- If the key blade section of the remote is not fully folded out when starting the vehicle, the immobilizer function may make it impossible to start the engine.
- After a cold start, idle speed may be noticeably higher than normal for a short period. This is done to help bring components in the emission control system to their normal operating temperature as quickly as possible, which enables them to control emissions and help reduce the vehicle's impact on the environment.
- To release the gear selector from the **P** (Park) position, the engine must be running (or the ignition key must be in position **II**) and the brake pedal must be depressed.
- Select the desired gear. The gear engages after a very slight delay which is especially noticeable when selecting **R**.

¹ If two of the keys to your vehicle are close together, e.g. on the same key ring when you try to start the vehicle, this could cause interference in the immobilizer system and result in the vehicle not starting. If this should occur, remove one of the keys from the key ring before trying to start the vehicle again.

² On vehicles equipped with the autostart feature, release the key immediately. See also page 145.



Starting the vehicle

NOTE

Your vehicle is equipped with a **KEYLOCK** system. When the engine is switched off, the gear selector must be in the **P** position before the key can be removed from the ignition switch.

When starting in cold weather, the transmission may shift up at slightly higher engine speeds than normal until the automatic transmission fluid reaches normal operating temperature.

NOTE

Do not race a cold engine immediately after starting. Oil flow may not reach some lubrication points fast enough to prevent engine damage.

WARNING

Always place the gear selector in Park and apply the parking brake before leaving the vehicle. Never leave the vehicle unattended with the engine running.

- Always open garage doors fully before starting the engine inside a garage to ensure adequate ventilation. The exhaust gases contain carbon monoxide, which is invisible and odorless but very poisonous.

CAUTION

Automatic transmission

- The engine should be idling when you move the gear selector. Never accelerate until after you feel the transmission engage! Accelerating immediately after selecting a gear will cause harsh engagement and premature transmission wear.
- Selecting **P** or **N** when idling at a standstill for prolonged periods of time will help prevent overheating of the automatic transmission fluid.



Ignition switch and steering wheel lock

Ignition switch and steering wheel lock

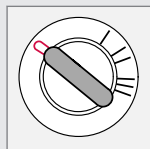

0 – Locked position:
Remove the key to lock the steering wheel^A.

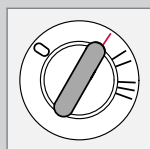

I – Intermediate position^B – "radio position":
Certain accessories, radio, etc. on, daytime running lights off.

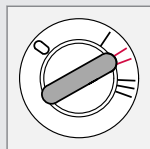

II – Drive position: The key position when driving. The vehicle's entire electrical system is connected.

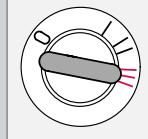

III – Start position:
Release the key when the engine starts. The key returns automatically to the Drive position.

A chime will sound if the key is left in the ignition and the driver's door is opened.

^A The gear selector must be in the P (Park) position (automatic transmission).

^B Please be aware that leaving the key in this position will increase battery drain.

Autostart

This function makes it possible to start the vehicle without holding the key in the start position (position III) until the engine starts. Turn the key to position III and release it. The starter motor will then operate automatically (for up to ten seconds) until the engine starts.

Steering wheel lock

The steering wheel lock might be under tension when the vehicle is parked.

Turn the steering wheel slightly to free the ignition key.

In order to help reduce vehicle theft, make sure the steering wheel lock is engaged before leaving the vehicle.

WARNING

Never switch off the ignition (turn the ignition key to position 0) or remove the key from the ignition switch while the vehicle is in motion. This could cause the steering wheel to lock, which would make the vehicle impossible to steer.



Economical driving

Economical driving conserves natural resources

Better driving economy may be obtained by thinking ahead, avoiding rapid starts and stops and adjusting the speed of your vehicle to immediate traffic conditions. Observe the following rules:

- Bring the engine to normal operating temperature as soon as possible by driving with a light foot on the accelerator pedal for the first few minutes of operation. A cold engine uses more fuel and is subject to increased wear.
- Whenever possible, avoid using the vehicle for driving short distances. This does not allow the engine to reach normal operating temperature.
- Drive carefully and avoid rapid acceleration and hard braking.
- Use the transmission's **D** (Drive) position as often as possible and avoid using "kickdown" to help improve fuel economy.
- Do not exceed posted speed limits.
- Avoid carrying unnecessary items (extra load) in the vehicle.
- Maintain correct tire pressure. Check tire pressure regularly (when tires are cold).
- Remove snow tires when threat of snow or ice has ended.

- Note that roof racks, ski racks, etc, increase air resistance and also fuel consumption.
- At highway driving speeds, fuel consumption will be lower with the air conditioning on and the windows closed than with the air conditioning off and the windows open.
- Using the onboard trip computer's fuel consumption modes can help you learn how to drive more economically.

Other factors that decrease gas mileage are:

- Dirty air cleaner
- Dirty engine oil and clogged oil filter
- Dragging brakes
- Incorrect front end alignment.

Some of the above mentioned items and others are checked at the standard Maintenance Service intervals.



CAUTION

Drive slowly and carefully if going through standing water (i.e. flooded roadways, etc.). Damage to the engine could result if excess water is drawn in through the air intake system. Never drive the vehicle in water deeper than 18 inches (48 cm).



Difficult driving conditions

Driving on rough/unpaved surfaces

The Volvo XC90 is designed primarily for on-road driving, and it has excellent handling characteristics on very rough or unpaved roads.

When driving on poorly maintained or unpaved roads, please keep the following in mind:

- Reduce speed on rough surfaces to minimize possible damage to the vehicle's underbody.
- When driving on soft surfaces such as dry sand or snow, try to avoid stopping if at all possible.

WARNING

- Avoid driving diagonally across steep inclines as this could increase the risk of a roll-over. Try to drive straight up or down the slope.
- If the road is very steep, avoid turning the vehicle around to help avoid the risk of rolling over. Back the vehicle up or down the incline instead.

NOTE

Avoid driving on steep inclines if the fuel tank is nearly empty. If the flow of fuel to the engine is interrupted due to the vehicle's angle of inclination, this could result in damage to the three-way catalytic converter. We recommend keeping the fuel tank at least half full when driving on steep inclines.

Driving through water

The vehicle can be driven through water up to a depth of approximately 16 inches (40 cm), at a maximum speed of 6 mph (10 km/h).

Take particular care when driving through flowing water.

Clean the electrical connections for trailer wiring after driving in mud or water.

When driving through water, maintain low speed and do not stop in the water.

WARNING

- Avoid driving through standing or rushing water. Doing so can be dangerous and it may also be difficult to determine the actual depth of the water.
- If water cannot be avoided, after driving through the water, press lightly on the brake pedal to ensure that the brakes are functioning normally. Water or mud can make the brake linings slippery, resulting in delayed braking effect.



Difficult driving conditions

CAUTION

- Engine damage will occur if water is drawn into the air cleaner.
- If the vehicle is driven through water deeper than 18 in (48 cm), water may enter the differential and the transmission. This reduces the oil's lubricating capacity and may shorten the service life of these components.
- Do not allow the vehicle to stand in water up to the door sills longer than absolutely necessary. This could result in electrical malfunctions.
- If the engine has been stopped while the car is in water, do not attempt to restart the engine. Have the car towed out of the water.



Automatic transmission

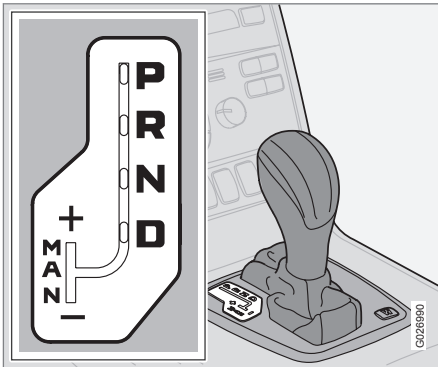

P (Park)

Use this position when starting the engine or parking the vehicle.

Never use **P** while the vehicle is in motion.

The parking brake should also be set whenever the vehicle is parked.

The gear selector is mechanically locked in the P position (SHIFTLOCK). To release the gear selector from this position, the engine must be running (or the ignition key must be in position **II**) and the brake pedal must be depressed.

N (Neutral)

Neutral – no gear engaged. Use the parking brake.

WARNING

Never leave the vehicle unattended when the engine is running. If, by mistake, the gear selector is moved from **P**, the vehicle may start moving.

R (Reverse)

Never engage **R** while the vehicle is moving.

D (Drive)

D is the normal driving position and should be used as often as possible to help improve fuel economy. The vehicle should not be moving when shifting from **R** to the **D** position.

NOTE

The transmission has 6 forward speeds.

Automatic transmission – shift gate positions

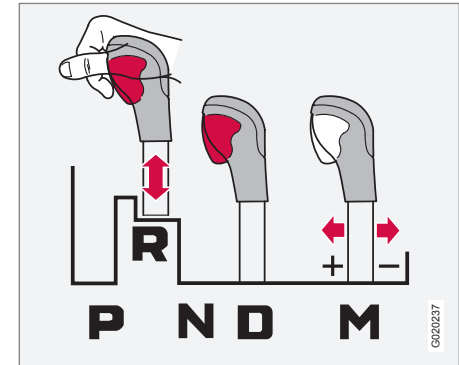

Shift gate positions

Depress the button on the front of the gear selector knob to move between the **R**, **N**, **D**, and **P** positions.

CAUTION

The transmission's temperature is monitored to help prevent damage to the transmission or other drivetrain components. If there is a risk of overheating, the warning symbol on the instrument panel will illuminate and a text message will be displayed. Follow the instructions provided there.



Automatic transmission

Kickdown

Automatic shift to a lower gear (kickdown) is achieved by depressing the accelerator pedal fully and briskly. An upshift will occur when approaching the top speed for a particular gear or by releasing the accelerator pedal slightly.

Kickdown can be used for maximum acceleration or when passing at highway speeds.

i NOTE

The gear selector must be in the **D** (Drive) position for kickdown to function.

Manual shifting – Geartronic

You can move the gear selector freely between the **MAN** (Manual) and **D** (Drive) positions to select forward gears while driving. Gears 3, 4, 5, and 6 have a "lock-up" function which reduces engine speed and helps save fuel.

i NOTE

Reverse, Neutral, and Park cannot be selected in Geartronic mode.

- A "lock-up" feature¹ reduces engine speed and help saves fuel.

The currently selected gear will be displayed in the instrument panel (see page 58).

- To access the **MAN** shifting position from **D**, move the gear selector to the left to **MAN**.
- To return to the **D** positions from **MAN**, move the gear selector to the right.

While driving

If you select the **MAN** position while driving, the gear that was being used in the **D** position will also initially be selected in **MAN** position.

- Move the gear selector forward (toward "+") to shift to a higher gear or rearward (toward "-") to shift to a lower gear.
- If you hold the gear selector toward "-", the transmission will downshift one gear and will utilize the braking power of the engine. If the current speed is too high for using a lower gear, the downshift will not occur until the speed has decreased enough to allow the lower gear to be used.
- If you slow down to a very low speed, the transmission will automatically shift down.

- When starting in the **MAN** position, 3rd gear is the highest gear that may be selected.

W – Winter/Wet driving mode – enhanced vehicle traction

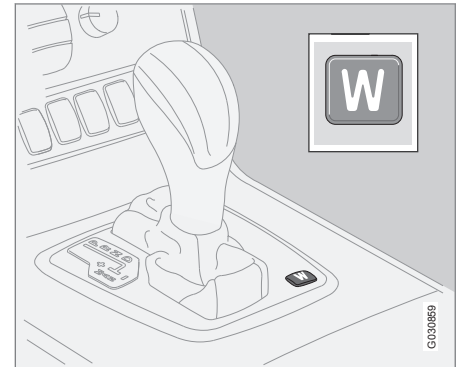

Press the **W** button at the base of the gear selector to engage/disengage this driving mode (see illustration). The **W** symbol will appear in the display (see page 58) when the function is activated.

This mode may be selected for starting/moving off on slippery roads. The vehicle

¹ Six-speed transmission: gears 2, 3, 4, 5, and 6.



Automatic transmission

starts off in 3rd gear to help maintain traction. First and second gears will only be used during kickdown.



NOTE

Mode **W** can be chosen regardless of the position of the gear selector but will only function when the gear selector is in the **D** (drive) position.



Jump starting

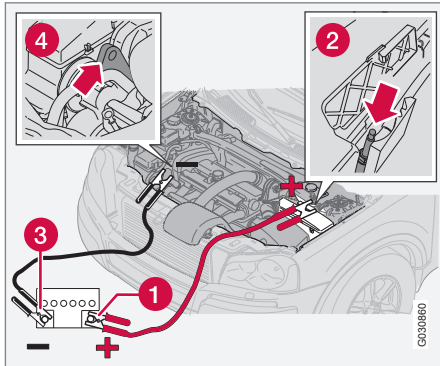

Follow these instructions to jump start your vehicle's dead battery or to jump start another vehicle's dead battery using your vehicle. Although your vehicle's battery is located under the floor of the cargo area, jumper cables should be connected in the **engine compartment**, to the points shown in the illustrations.

If the 12-volt auxiliary battery to be used is in another vehicle, check that the vehicles are not touching to prevent premature completion of a circuit. Be sure to follow jump starting instructions provided for the other vehicle.

To jump start your vehicle:

1. Switch off the ignition.
2. First connect the auxiliary battery positive (+) terminal (1) to the positive (+) terminal in your vehicle's engine compartment (2), located under a small black plastic cover attached to the fuse box cover, marked with a "+" sign. Remove the cover on the main fuse box if necessary to access this terminal. Then connect the auxiliary battery's negative (-) terminal (3) to the ground point in your vehicle's engine compartment (4).
3. Start the engine in the assisting vehicle, then start the engine in the vehicle with dead battery.
4. After the engine has started, first remove the negative (-) terminal jumper cable. Then remove the positive (+) terminal jumper cable.

WARNING

PROPOSITION 65 WARNING!

Battery posts, terminals, and related accessories contain lead and lead compounds, chemicals known to the state of California to cause cancer and reproductive harm. Wash hands after handling.

WARNING

- Do not connect the jumper cable to any part of the fuel system or to any moving parts. Avoid touching hot manifolds.
- Never expose the battery to open flame or electric spark.
- Do not smoke near the battery.
- Batteries generate hydrogen gas, which is flammable and explosive.
- Battery fluid contains sulfuric acid. Do not allow battery fluid to contact eyes, skin, fabrics or painted surfaces. If contact occurs, flush the affected area immediately with water. Obtain medical help immediately if eyes are affected.
- Failure to follow the instructions for jump starting can lead to personal injury.

**All Wheel Drive*****All Wheel Drive (AWD) – general information**

Your Volvo can be equipped with an electronically controlled All Wheel Drive system*, which means that power is distributed automatically between the front and rear wheels. Under normal driving conditions, most of the engine's power is directed to the front wheels. However, if there is any tendency for the front wheels to spin, an electronically controlled coupling distributes power to the wheels that have the best traction.

Tire dimensions

Volvo recommends that you always drive on tires of the same brand, size, construction (radial), tread pattern, load-, speed-, traction-, temperature-, and treadwear rating. Never drive on mixed tires, except for brief periods when the temporary spare tire is in use.

Always use properly inflated tires of correct dimensions. Tire size and inflation pressures are shown on the tire inflation pressure placards, located on the driver's side B-pillar (the structural member at the side of the vehicle, at the rear of the driver's door opening), or on the inside of the fuel filler door on Canadian models.

Temporary Spare

The temporary spare tire is for temporary, low-speed, short-distance use only. Replace it with a full-sized tire as soon as possible. Do not drive on the temporary spare at speeds above 50 m.p.h. (80 km/h).

 NOTE

Never install snow chains on a temporary spare.



Brake system

BRAKE Brake circuit malfunction

The brake system is a hydraulic system consisting of two master cylinders and two separate brake circuits. If a problem should occur in one of these circuits, it is still possible to stop the vehicle with the other brake circuit.

If the brake pedal must be depressed farther than normal and requires greater foot pressure, the stopping distance will be longer.

A warning light in the instrument panel will light up to warn the driver that a fault has occurred.

If this light comes on while driving or braking, stop immediately and check the brake fluid level in the reservoir.

NOTE

Press the brake pedal hard and maintain pressure on the pedal – do not pump the brakes.

WARNING

If the fluid level is below the **MIN** mark in the reservoir or if a **BRAKE FAILURE STOP SAFELY** message is displayed in the text window: **DO NOT DRIVE**. Have the vehicle towed to a trained and qualified Volvo service technician and have the brake system inspected.

NOTE

When the vehicle is at a standstill and the engine is idling, e.g. at a traffic light and the brake pedal is depressed, the pedal may go down slightly. This is a normal function of the power-assisted brake system.

Brake pad inspection

On vehicles equipped with a jack*, the condition of the brake pads can be checked by raising the vehicle (see page 198 for information about using the jack and removing a wheel) and performing a visual inspection of the brake pads.

WARNING

- If the vehicle has been driven immediately prior to a brake pad inspection, the wheel hub, brake components, etc., will be very hot. Allow time for these components to cool before carrying out the inspection.
- Apply the parking brake and put the gear selector in the Park (**P**) position.
- Block the wheels standing on the ground, use rigid wooden blocks or large stones.



Brake system

WARNING

- Use the jack intended for the vehicle when changing a tire. For any other job, use stands to support the vehicle.
- The jack should be kept well-greased and clean, and should not be damaged.
- Be sure the jack is on a firm, level, non-slippery surface.
- No objects should be placed between the base of jack and the ground, or between the jack and the attachment bar on the vehicle.
- The jack must correctly engage the jack attachment.
- Never allow any part of your body to be extended under a vehicle supported by a jack.

Power brakes function only when the engine is running

The power brakes utilize vacuum pressure which is only created when the engine is running. Never let the vehicle roll to a stop with the engine switched off.

If the power brakes are not working, considerably higher pressure will be required on the brake pedal to compensate for the lack of power assistance. This can happen for exam-

ple when towing your vehicle or if the engine is switched off when the vehicle is rolling. The brake pedal feels harder than usual.

Water on brake discs and brake pads affects braking

Driving in rain and slush or passing through an automatic car wash can cause water to collect on the brake discs and pads. This will cause a delay in braking effect when the pedal is depressed. To avoid such a delay when the brakes are needed, depress the pedal occasionally when driving through rain, slush etc. This will remove the water from the brakes. Check that brake application feels normal. This should also be done after washing or starting in very damp or cold weather.

Severe strain on the brake system

The brakes will be subject to severe strain when driving in mountains or hilly areas, or when towing a trailer. Vehicle speed is usually slower, which means that the cooling of the brakes is less efficient than when driving on level roads. To reduce the strain on the brakes, shift into a lower gear and let the engine help with the braking. Do not forget that, if you are towing a trailer, the brakes will be subjected to a greater than normal load.

Anti-lock brakes (ABS)

If the **ABS** warning lamp lights up there is a malfunction in the ABS system (the standard braking system will however function) and the vehicle should be driven cautiously to a trained and qualified Volvo service technician for inspection. The Anti-lock Braking System (ABS) helps to improve vehicle control (stopping and steering) during severe braking conditions by limiting brake lockup. When the system "senses" impending lockup, braking pressure is automatically modulated in order to help prevent lockup, which could lead to a skid.

The system performs a self-diagnostic test when the engine is started and when the vehicle first reaches a speed of approximately 12 mph (20 km/h). The brake pedal will pulsate several times and a sound may be audible from the ABS control module. This is normal.

To obtain optimal effect from the ABS system, constant pressure should be kept on the brake pedal. Do not pump the brake pedal.

The switching of the ABS modulator will be audible and the brake pedal will pulsate during braking. Please be aware that ABS does not increase the absolute braking potential of the vehicle. While control will be enhanced, ABS will not shorten stopping distances on slippery surfaces.



Brake system

ABS with EBD (Electronic Brake Force Distribution)

EBD is an integrated part of the ABS system. EBD regulates the hydraulic pressure to the rear brakes to help provide optimal braking capacity. The brake pedal will pulsate during braking, which is normal.

If the BRAKE and ABS warning lights come on at the same time, this could indicate a fault in the brake system.

1. Stop the vehicle in a suitable place and switch off the engine.
 2. Restart the engine.
- If both warning lights go off, no further action is required.
 - If both lights are still on after the engine has been restarted, switch off the engine again and check the brake fluid level (see page 225 for the location of the brake fluid reservoir).

WARNING

If the fluid level is below the **MIN** mark in the reservoir or if a **Brake failure – Service urgent** message is displayed in the text window: DO NOT DRIVE. Have the vehicle towed to a trained and qualified Volvo service technician and have the brake system inspected.

- If the brake fluid level is above the **MIN** mark, drive carefully to a trained and qualified Volvo service technician and have the brake system inspected.

Emergency Brake Assistance (EBA)

The EBA function is designed to provide full brake effect immediately in the event of sudden, hard braking. The system is activated by the speed with which you depress the brake pedal.

NOTE

- When the EBA system is activated, the brake pedal will go down and pressure in the brake system immediately increases to the maximum level. You must maintain full pressure on the brake pedal in order to utilize the system completely. There will be no braking effect if the pedal is released. EBA is automatically deactivated when the brake pedal is released.
- When the vehicle has been parked for some time, the brake pedal may sink more than usual when the engine is started. This is normal and the pedal will return to its usual position when it is released.



Parking brake

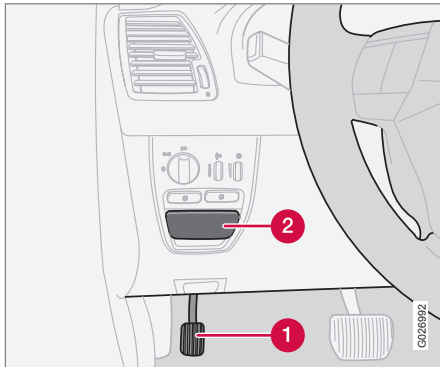

- 1 Parking brake pedal
- 2 Handle for releasing the parking brake

The parking brake pedal is located under the dashboard, to the left of the brake pedal.

i NOTE

The indicator light will light up even if the parking brake has only been partially applied.

When applying the parking brake

1. Press firmly on the brake pedal.

2. Press down pedal (1) firmly to its full extent.
3. Release the brake pedal and ensure that the vehicle is at a standstill.
4. If the vehicle rolls, the parking brake pedal must be pushed down more firmly.
5. When parking a vehicle always put the gear selector in **P**.

Parking on a hill

- If the vehicle is pointing uphill, turn the front wheels so that they point away from the curb.
- If the vehicle is pointing downhill, turn the front wheels so that they point toward the curb.

Releasing the parking brake

1. Press firmly on the brake pedal.
2. Pull handle (2).

i NOTE

If you inadvertently pull the plastic cover, it can be pressed back into place.

⚠ WARNING

Press down the parking brake pedal firmly to its full extent.



Stability system

Dynamic Stability Traction Control (DSTC)

The stability system consists of a number of functions designed help reduce wheel spin, counteract skidding, and to generally help improve directional stability.

i NOTE

A pulsating sound will be audible when the system is actively operating and is normal.

Traction control (TC)

This function is designed to help reduce wheel spin by transferring power from a drive wheel that begins to lose traction to the wheel on the opposite side of the vehicle (on the same axle).

TC is most active at low speeds.

This is one of DSTC's permanent functions and cannot be switched off.

Spin control (SC)

The spin control function is designed to help prevent the drive wheels from spinning while the vehicle is accelerating.

Under certain circumstances, such as when driving with snow chains, or driving in deep snow or loose sand, it may be advisable to

temporarily switch off this function for maximum tractive force.

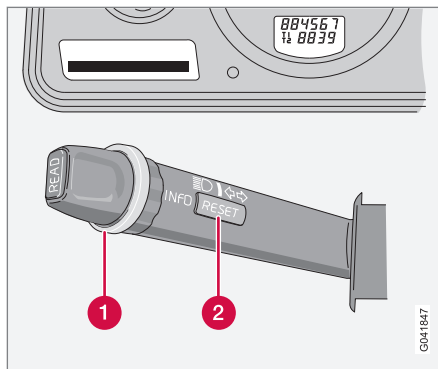

Temporarily switching off Spin control

1. Turn the thumbwheel (1) on the left-side steering wheel lever until the **DSTC menu** is displayed.
2. Hold down the **RESET** button (2) to toggle between **DSTC ON** or **DSTC SPIN CONTROL OFF**.

i NOTE

- The message **DSTC SPIN CONTROL OFF** indicates that the stability system's spin control function has temporarily been switched off.
- The stability control indicator light will illuminate and remain on until spin control has been reactivated.
- The spin control function is automatically enabled each time the engine is started.
- **DSTC ON** indicates that all system functions are active.

Active Yaw Control (AYC)

This function helps maintain directional stability, for example when cornering, by braking one or more of the wheels if the vehicle shows a tendency to skid or slide laterally.

This is one of **DSTC**'s permanent functions and cannot be switched off.

! WARNING

The car's handling and stability characteristics will be altered if the DSTC system functions have been disabled.



Stability system

DSTC-related messages in the text window

- **TRACTION CONTROL TEMPORARILY OFF** : The system has been temporarily switched off due to high brake temperature and will automatically switch on again when the brakes have cooled.
- **ANTI-SKID SERVICE REQUIRED**: The system has been automatically disengaged due to a fault. A trained and qualified Volvo service technician should check the system.

Symbols in the instrument panel

The Stability Control indicator light



This light indicates different conditions, depending on how it illuminates.

The Stability Control indicator light illuminates for approximately 2 seconds

This indicates that the system is performing a self-diagnostic test when the ignition is switched on.

The Stability Control indicator light flashes

This indicates that the stability system is actively functioning to help counteract wheel spin and/or a skid.

The Stability Control indicator light glows steadily

ANTI-SKID SERVICE REQUIRED will be displayed in the text window at the same time.

A fault is indicated in the stability system.

- Stop the vehicle in a safe place and switch off the engine.
- Restart the engine.
- If the indicator light goes out, the fault was temporary and no further action is required.
- If the indicator light remains on, drive to an authorized Volvo workshop as soon as possible to have the system checked.

The Stability Control indicator light glows steadily

If **DSTC SPIN CONTROL OFF** is displayed in the text window at the same time, this is a reminder that spin control has been disabled by the driver.

The warning symbol



The warning symbol glows steadily yellow

The system has been temporarily switched off due to high brake temperature.

TRACTION CONTROL TEMPORARILY OFF will be displayed. The system will automatically switch on again when the brakes have cooled.

WARNING

The stability system is intended to help improve driving safety. It supplements, but can never replace, the driver's judgement and responsibility when operating the vehicle. Speed and driving style should always be adapted to traffic and road conditions.



Front/rear park assist*

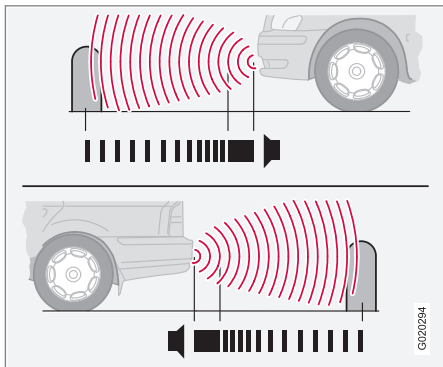

Front/rear park assist

The park assist system is designed to assist you when driving into parking spaces, garages, etc. It utilizes four ultrasound sensors located in one or both bumpers to measure the distance to a vehicle, object, or a person who may be close to the front or rear of your vehicle.

Park assist is available in two versions:

- Rear bumper only
- Front and rear bumpers

WARNING

Park Assist is an information system, NOT a safety system. This system is designed to be a supplementary aid when parking the vehicle. It is not, however, intended to replace the driver's attention and judgement.

Function

The system is activated automatically when the vehicle is started. The indicator light in the button in the center console illuminates.

- The front park assist system is active from the time the engine is started until the vehicle exceeds a speed of approximately 10 mph (15 km/h). It is also active when the vehicle is backing up.
- Rear park assist is active when the engine is running and reverse gear has been selected.

Rear park assist

The distance monitored behind the vehicle is approximately 5 ft (1.5 m). The signal comes from the rear speakers.

The system must be deactivated when towing a trailer, carrying bicycles in a rear-mounted carrier, etc, which could trigger the rear park assist system's sensors.

NOTE

Rear park assist is deactivated automatically when towing a trailer if Volvo genuine trailer wiring is used.

Front park assist

The distance monitored in front of the vehicle is approximately 2.5 ft (0.8 m). The audible signal comes from the audio system's front speakers.

- It may not be possible to combine auxiliary headlights and front park assist since these lights could trigger the system's sensors.

Activating/deactivating park assist

The system is activated automatically when the vehicle is started.

- Press the Park assist button on the center console (see page 65) to temporarily deactivate the system(s). The indicator light in the button will go out when the system has been deactivated.
- Park assist will be automatically reactivated the next time the engine is started, or if the button is pressed (the indicator light in the button will illuminate).



Front/rear park assist*

i NOTE

- Front park assist is disengaged automatically when the parking brake is applied.
- If the vehicle is equipped with front and rear park assist, both systems will be deactivated by pressing the button.

Audible signals from the park assist system

The Park Assist system uses an intermittent tone that pulses faster as you come close to an object, and becomes constant when you are within approximately 1 ft (30 cm) of an object in front of or behind the vehicle. If the volume of another source from the audio system is high, this will be automatically lowered.

If there are objects within this distance both behind and in front of the vehicle, the signal alternates between front and rear speakers.

Faults in the system



If the yellow warning symbol illuminates and **PARK ASSIST SERVICE REQUIRED** is shown on the information display, this indicates that the system is not functioning properly and has been disengaged. Consult a trained and qualified Volvo service technician.

i CAUTION

In certain circumstances, the park assist system may give unexpected warning signals that can be caused by external sound sources that use the same ultrasound frequencies as the system. This may include such things as the horns of other vehicles, wet tires on asphalt, pneumatic brakes, motorcycle exhaust pipes, etc. This does not indicate a fault in the system.

Cleaning the sensors

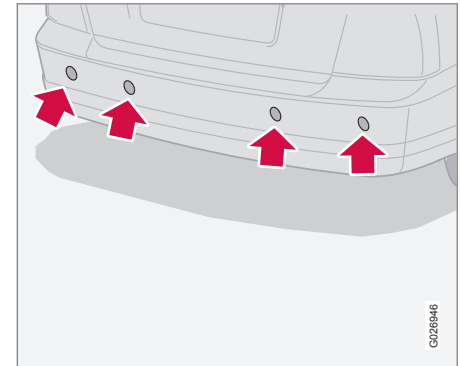

Park assist sensors

The sensors must be cleaned regularly to ensure that they work properly. Clean them with water and a suitable car washing detergent.

Ice and snow covering the sensors may cause incorrect warning signals.

i NOTE

If the sensors are obstructed by e.g., dirt, snow, or ice, this could result in false warning signals from the park assist system.

* Option/accessory, for more information, see Introduction.



Towing

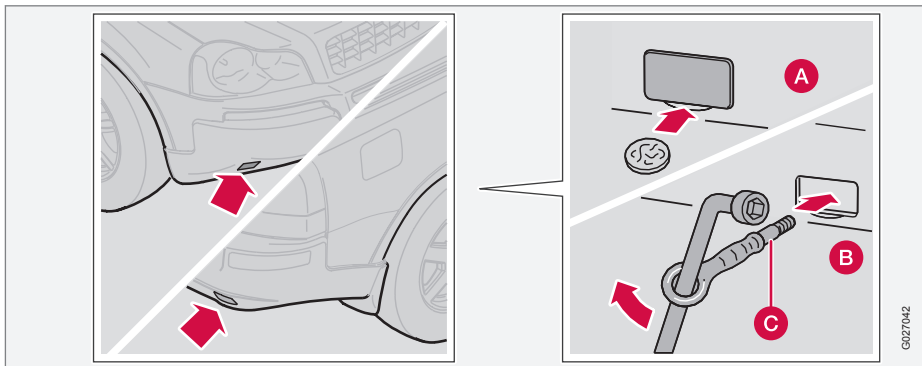

Positions for attaching towing eyelets

Emergency towing

The towing eyelet is located in the tool bag, under the floor of the cargo area. This eyelet must be screwed into the positions provided on the right sides of either the front or rear bumper (see illustrations).

To attach the towing eyelet:

1. Use a coin to pry open the lower edge of the cover (A)
2. Screw the towing eyelet (C) in place (B), first by hand and then using the tire iron until it is securely in place.

After the vehicle has been towed, the eyelet should be removed and returned to the tool bag. Press the cover back into position.

WARNING

Do not use the towing eyelets to pull the vehicle up onto a flat bed tow truck.

Precautions when the vehicle is in tow

- The steering wheel must be unlocked. Turn the ignition key to position **I** or **II**.
- The gear selector must be in position **N**.

- Maximum speed: 50 mph (80 km/h). Do not exceed the maximum allowable towing speed.
- Maximum distance with front wheels on ground: 50 miles (80 km).
- While the vehicle is being towed, try to keep the tow rope taut at all times.
- The vehicle should only be towed in the forward direction.



Towing

! CAUTION

Vehicles with AWD (All Wheel Drive) with the front wheels off the ground should not be towed at speeds above 50 mph (70 km/h) or for distances longer than 30 miles (50 km).

! CAUTION

- Please check with state and local authorities before attempting this type of towing, as vehicles being towed are subject to regulations regarding maximum towing speed, length and type of towing device, lighting, etc.
- If the vehicle's battery is dead, do not attempt to start the vehicle by pushing or pulling it as this will damage the three-way catalytic converter(s). The engine must be jump started using an auxiliary battery (see page 152).
- If the vehicle is being towed on a flat bed truck, the towing eyelets must not be used to pull the vehicle up onto the flat bed or to secure the vehicle on the flat bed. Consult the tow truck operator.

! WARNING

- The power brakes and power steering will not function when the engine is not running. Approximately 5 times more pressure will be required on the brake pedal and the steering wheel will be considerably harder to turn.
- The towing eyelets must not be used for pulling the vehicle out of a ditch or for any similar purpose involving severe strain.

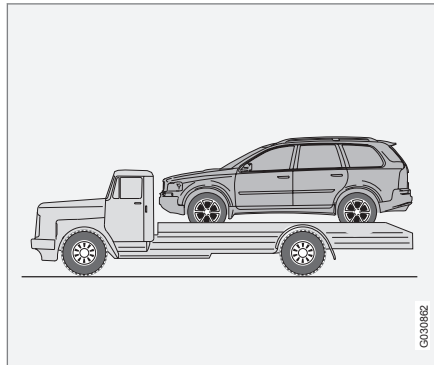

Towing vehicles with front wheel drive/All Wheel Drive

Volvo recommends the use of flat bed equipment.

If wheel lift equipment must be used, please use extreme caution to help avoid damage to the vehicle. **In this case, the vehicle should be towed with the rear wheels on the ground if at all possible.**

If it is absolutely necessary to tow the vehicle with the front wheels on the ground, please refer to the towing information on the previous page.

! CAUTION

- Sling-type equipment applied at the front will damage radiator and air conditioning lines.
- It is equally important not to use sling-type equipment at the rear or apply lifting equipment inside the rear wheels; serious damage to the rear axle may result.
- If the vehicle is being towed on a flat bed truck, the towing eyelets must not be used to secure the vehicle on the flat bed. Consult the tow truck operator.



06 Starting and driving

Towing a trailer

The maximum weights recommended by Volvo for trailers **with brakes** are shown in the table below.

Recommended hitch tongue load: not more than 10% of the trailer's weight. The

trailer load should be positioned so that it does not shift and the tongue load should be 10% of the trailer's weight. However, the tongue load should not exceed the maximum

permissible weights indicated in the table below.

No. of occupants	1	2	3	4	5	6	7
Seating position	Front seat	Front seat	2nd row of seats	2nd row of seats	2nd row of seats	3rd row of seats*	3rd row of seats*
All Wheel Drive	5,000 lbs (2250 kg)	5,000 lbs (2250 kg)	4,500 lbs (2050 kg)	3,700 lbs (1700 kg)	2,900 lbs (1350 kg)	1,800 lbs (800 kg)	Trailer towing not recommended
Max. trailer hitch tongue load	500 lbs (225 kg)	500 lbs (225 kg)	450 lbs (205 kg)	370 lbs (170 kg)	290 lbs (135 kg)	180 lbs (80 kg)	–
Front Wheel Drive	4,000 lbs (1800 kg)	4,000 lbs (1800 kg)	4,000 lbs (1800 kg)	4,000 lbs (1800 kg)	3,700 lbs (1650 kg)	2,500 lbs (1150 kg)	1,400 lbs (650 kg)
Max. trailer hitch tongue load	400 lbs (180 kg)	400 lbs (180 kg)	400 lbs (180 kg)	400 lbs (180 kg)	370 lbs (165 kg)	250 lbs (115 kg)	140 lbs (65 kg)

06

* Option/accessory, for more information, see Introduction.



Towing a trailer

Points to keep in mind when towing a trailer

- When towing trailers **without** brakes, the maximum permissible trailer weight is 1,700 lbs (750 kg).
- If necessary, redistribute the weight of any cargo in the trailer to avoid excessive weight on the trailer hitch.
- The maximum trailer weight listed in the table for All Wheel Drive models, 5,000 lbs (2250 kg) is only applicable when there are not more than two occupants in the vehicle, in the front seats, with a combined weight of 300 lbs (135 kg), with no other cargo in the vehicle.
- The maximum weight listed for Front Wheel Drive models, 4,000 lbs (1800 kg) is only applicable when there are not more than four occupants in the vehicle, in the front seats and second row of seats, with a combined weight of 600 lbs (270 kg), with no other cargo in the vehicle.
- Vehicles used for towing a trailer on a regular basis, or for long-distance highway towing should be equipped with an automatic transmission oil cooler and Volvo's automatic self-leveling system for the rear suspension. Consult your Volvo retailer.
- Volvo recommends the use of Volvo trailer hitches that are specially designed for the vehicle.
- All Volvo models are equipped with energy-absorbing shock-mounted bumpers. Trailer hitch installation should not interfere with the proper operation of this bumper system.
- Increase tire pressure to recommended full inflation pressure. See chapter "Wheels and tires."
- When your vehicle is new, avoid towing heavy trailers during the first 620 miles (1,000 km).
- Engine and transmission are subject to increased loads. Therefore, engine coolant temperature should be closely watched when driving in hot climates or hilly terrain. Use a lower gear and turn off the air conditioner if the temperature gauge needle enters the red range.
- If the automatic transmission begins to overheat, a message will be displayed in the text window.
- Hauling a trailer affects handling, durability, and economy.
- It is necessary to balance trailer brakes with the towing vehicle brakes to provide a safe stop (check and observe state/local regulations).
- Do not connect the trailer's brake system directly to the vehicle's brake system.
- Remove the ball and drawbar assembly when the hitch is not being used.
- Volvo recommends the use of synthetic engine oil when towing a trailer over long distances or in mountainous areas.



NOTE

- When parking the vehicle with a trailer on a hill, apply the parking brake before putting the gear selector in **P**. When starting on a hill, put the gear selector in **D** before releasing the parking brake. Always follow the trailer manufacturer's recommendations for wheel chocking.
- If you use the manual (Geartronic) shift positions while towing a trailer, make sure the gear you select does not put too much strain on the engine (using too high a gear).



Towing a trailer

WARNING

- Bumper-attached trailer hitches must not be used on Volvos, nor should safety chains be attached to the bumper.
- Trailer hitches attaching to the vehicle rear axle must not be used.
- Never connect a trailer's hydraulic brake system directly to the vehicle brake system, nor a trailer's lighting system directly to the vehicle lighting system. Consult a trained and qualified Volvo service technician for correct installation.
- When towing a trailer, the trailer's safety wire must be correctly fastened to the hole or hook provided in the trailer hitch on the vehicle. The safety wire should never be fastened to or wound around the drawbar ball.

Leveling

If your vehicle is equipped with automatic leveling, the rear suspension always retains the correct ride height regardless of the load.

- The system adjusts the rear suspension to the correct level after the vehicle has been driven a short distance.
- When the vehicle is stationary, the rear suspension lowers, which is normal.



Detachable trailer hitch

Overview

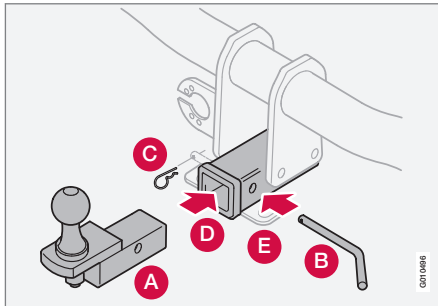

- A** Ball holder
- B** Locking bolt
- C** Cotter pin
- D** Hitch assembly
- E** Safety wire attachment

Installing the ball holder

1. If necessary, remove the cotter pin from the locking bolt and slide the locking bolt out of the hitch assembly.
2. Slide the ball holder into the hitch assembly.
3. Align the hole in the ball holder with the one in the hitch assembly.

4. Slide the locking bolt through the hitch assembly/ball holder.
5. Insert the cotter pin in the hole at the end of the locking bolt.

Removing the ball holder

1. Remove the cotter pin from the locking bolt and slide the locking bolt out of the ball holder/hitch assembly.
2. Pull the ball holder out of the hitch assembly.

A cover for the hitch assembly can be purchased from your Volvo retailer.



Load carriers (accessory)

Positioning load carriers

If wing-shaped load carriers are used, make sure that they are installed on the roof rails with the rounded edge forward. Load carriers of this type are identical and can be placed anywhere along the roof rails.

When not in use, we recommend that the front load carrier be placed approximately 2 inches (5 cm) in front of the center roof rail anchorage point and the rear load carrier approximately 1.5 inches (3.5 cm) in front of the rear rail anchorage. This will help to reduce wind noise.

Installing load carriers

Make sure that the load carriers are pressed firmly out against the roof rail and securely tightened in place. Check regularly that any load carriers are securely in place.

WARNING

Loads carried on the vehicle's roof should not exceed 220 lbs (100 kg), including the weight of the load carriers and any other load carrying equipment (ski boxes, bicycle racks, etc.). Excessive loads on the roof can adversely affect the handling and roadholding characteristics of the vehicle.



Cold weather precautions

If you wish to check your vehicle before the approach of cold weather, the following advice is worth noting:

- Make sure that the engine coolant contains 50 percent antifreeze. Any other mixture will reduce freeze protection. This gives protection against freezing down to -31°F (-35°C). See section "Coolant".
- **The use of "recycled" antifreeze is not approved by Volvo. Different types of antifreeze must not be mixed.**
- Volvo recommends using only genuine Volvo antifreeze in your vehicle's radiator. Your Volvo retailer stocks plenty of Volvo engine coolant to protect your vehicle during cold weather.
- Try to keep the **fuel tank** well filled – this prevents the formation of condensation in the tank. In addition, in extremely cold weather conditions it is worthwhile to add fuel line de-icer before refueling.
- The viscosity of the engine oil is important. Oil with low viscosity (thinner oil) improves cold-weather starting as well as decreasing fuel consumption while the engine is warming up. Full synthetic 0W-30 oil is recommended for driving in areas with sustained low temperatures.
- The load placed on the **battery** is greater during the winter since the windshield wipers, lighting, etc. are used more often.

Moreover, the capacity of the battery decreases as the temperature drops. In very cold weather, a poorly charged battery can freeze and be damaged. It is therefore advisable to check the state of charge more frequently and spray an anti-rust oil on the battery posts.

- Volvo recommends the use of **snow tires** on all four wheels for winter driving – see section "Wheels and tires."
- To prevent the **washer fluid reservoir** from freezing, add washer solvents containing antifreeze (see page 224 for the location of the washer fluid reservoir). This is important since dirt is often splashed on the windshield during winter driving, requiring the frequent use of the washers and wipers. Volvo Washer Solvent should be diluted as follows:
 - **Down to 14°F (-10°C):** 1 part washer solvent and 4 parts water
 - **Down to 5°F (-15°C):** 1 part washer solvent and 3 parts water
 - **Down to 0°F (-18°C):** 1 part washer solvent and 2 parts water
 - **Down to -18°F (-28°C):** 1 part washer solvent and 1 part water
- Use Volvo Teflon Lock Spray in the locks.



NOTE

Avoid the use of de-icing sprays as they can cause damage to the locks.

W – Winter/Wet driving mode – enhanced vehicle traction

- Mode W will only function if the gear selector is in the **(D)**rive position.
- Press the button at the base of the gear selector to engage/disengage this driving mode.
- An LED in the button will light up to indicate that W is engaged and this will also be displayed in the instrument panel (see page 58).
- This mode may be selected for starting/moving off on slippery roads.



Before a long distance trip

It is always worthwhile to have your vehicle checked by a trained and qualified Volvo service technician before driving long distances. Your retailer or service technician will also be able to supply you with bulbs, fuses, spark plugs and wiper blades for your use in the event that problems occur.

As a minimum, the following items should be checked before any long trip:

- Check that engine runs smoothly and that fuel consumption is normal.
 - Check for fuel, oil, and fluid leakage.
 - Check transmission oil level¹.
 - Check condition of drive belts.
 - Check state of the battery's charge.
 - Examine tires carefully (the spare tire as well), and replace those that are worn. Check tire pressures.
 - The brakes, front wheel alignment, and steering gear should be checked by a trained and qualified Volvo service technician only.
 - Check all lights, including high beams.
 - Reflective warning triangles are legally required in some states/provinces.
- Have a word with your Volvo retailer if you intend to drive in countries where it may be difficult to obtain the correct fuel.
 - Consider your destination. If you will be driving through an area where snow or ice are likely to occur, consider snow tires.

¹ To prevent injury from contact with hot surfaces, do not inspect your vehicle's transmission fluid yourself. Have your vehicle's transmission fluid level inspected by a qualified Volvo service technician.



Blind Spot Information System*

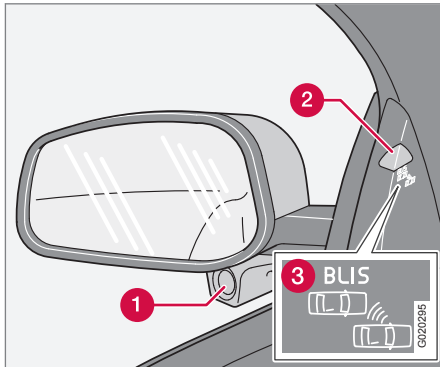

- 1 BLIS camera
- 2 Indicator light
- 3 BLIS symbol

The Blind Spot Information System (BLIS) is an information system that indicates the presence of another vehicle moving in the same direction as your vehicle in the side-view mirror's "blind area."

The system is based on digital camera technology. The cameras (1) are located beneath the side-view mirrors.

When one (or both) of the cameras have detected a vehicle in the blind area (up to

approximately 10 ft. (3 meters) from the side of your vehicle, and up to approximately 31 ft. (9.5 meters) behind the side-view mirror, see the illustration, the indicator light in the door panel (2) illuminates. The light will glow continuously to alert the driver of the vehicle in the blind area.

WARNING

- BLIS is an information system, NOT a warning or safety system.
- BLIS does not eliminate the need for you to visually confirm the conditions around you, and the need for you to turn your head and shoulders to make sure that you can safely change lanes.
- As the driver, you have full responsibility for changing lanes in a safe manner.

NOTE

The door panel indicator light illuminates on the side of the vehicle where the system has detected another vehicle. If your vehicle is passed on both sides at the same time, both lights will illuminate.

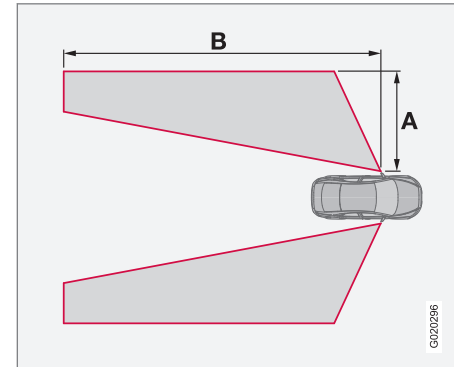

Areas monitored by BLIS

Distance A = approx. 10 ft. (3 meters)

Distance B = approx. 31 ft. (9.5 meters)

BLIS has an integrated function that alerts the driver if a fault should occur with the system. For example, if one or both of the system's cameras are obscured, a message (see the table on page 173) will appear in the information display in the instrument panel. If this occurs, clean the camera lenses. If necessary, the system can be temporarily switched off (for instructions, see page 173).

When does BLIS function

The system functions when your vehicle is moving at speeds above 6 mph (10 km/h).

* Option/accessory, for more information, see Introduction.



Blind Spot Information System*

When you pass another vehicle:

The system reacts when you pass another vehicle at a speed of up to 6 mph (10 km/h) faster than that vehicle.

When you are passed by another vehicle:

The system reacts if your vehicle is passed by another vehicle at a speed of up to 43 mph (70 km/h) faster than your vehicle.

WARNING

- BLIS does not function in sharp curves.
- BLIS does not function when your vehicle is backing up.
- If you are towing a wide trailer, this may prevent the BLIS cameras from detecting other vehicles in adjacent lanes.

How BLIS functions in daylight and darkness

Daylight

BLIS reacts to the **shape** of surrounding vehicles. The system is designed to help detect motor vehicles such as cars, trucks, buses, motorcycles, etc.

Darkness

BLIS reacts to the **headlights** of surrounding vehicles. In order to be detected by BLIS, a vehicle in the blind area must have its headlights on. This means, for example, that the system will not detect a trailer without headlights that is being towed behind a car or truck.

WARNING

- BLIS does not react to cyclists or mopeds.
- BLIS does not react to vehicles that are standing still.
- The BLIS cameras have the same limitation as the human eye. In other words, their "vision is impaired" by adverse weather conditions such as heavy snowfall, intense light directly into the camera, dense fog, etc.

Cleaning the BLIS camera lenses

In order to function optimally, the BLIS camera lenses must be kept clean. They can be wiped clean with a soft cloth or wet sponge.

CAUTION

- Clean the lenses carefully to avoid scratching.
- The lenses are electrically heated to help melt ice or snow. If necessary, gently brush away snow from the lenses.

Limitations

In certain situations, the BLIS indicator light(s) may illuminate even when there are no other vehicles in the area monitored by the system.

NOTE

If the BLIS indicator lights illuminate occasionally even when there are no other vehicles in the blind area, this does not indicate a fault in the system.

In the event of a fault, **Blind spot syst. service required** will be displayed.

The following are several examples of situations in which the BLIS indicator light(s) may illuminate even when there are no other vehicles in the area monitored by the system.



Blind Spot Information System*

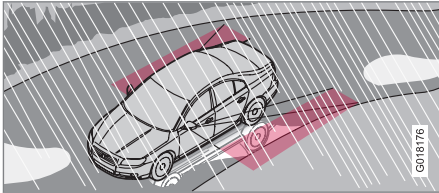

Light reflected from a wet road surface

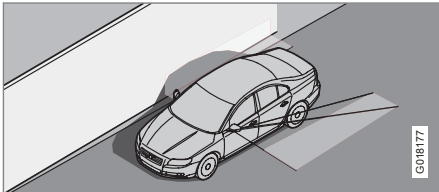

The vehicle's own shadow against a large, light, smooth surface such as barriers between lanes on a highway

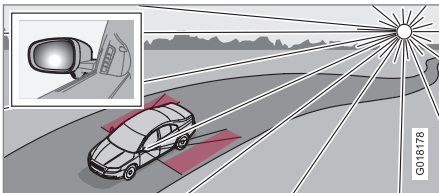

Sunlight directly in the camera when the sun is low on the horizon

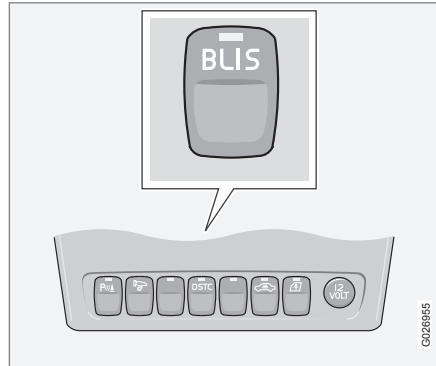

Switching BLIS on and off

BLIS is automatically activated when the ignition is switched on. The indicator lights will provide confirmation by flashing 3 times.

- The system can be switched off by pressing the **BLIS** button in the center console (see the illustration). The indicator light in the button goes out when the system is switched off, and a text message is displayed.
- **BLIS** can be switched on again by pressing the button. The indicator light in the button will illuminate and a new text message will be displayed. Press the **READ** button (see page 62) to erase the message.

System status	Text in the display
BLIND-SPOT SYST SERVICE REQUIRED	BLIS not functioning properly. Contact an authorized Volvo service technician.
BLIND-SPOT SYST R CAMERA BLOCKED	The right side BLIS camera is obscured. Clean the lenses.
BLIND-SPOT SYST L CAMERA BLOCKED	The left side BLIS camera is obscured. Clean the lenses.
BLIND-SPOT SYST CAMERAS BLOCKED	BLIS camera obscured. Clean the lenses.
BLIND-SPOT INFO SYSTEM OFF	BLIS system off



Blind Spot Information System*

System status	Text in the display
BLIND-SPOT INFO SYSTEM ON	BLIS system on
BLIND-SPOT SYST FUNC- TION REDUCED	The BLIS cameras' function has been reduced due to weak or impaired data transfer between the BLIS system's cameras and the vehicle's electrical system. The cameras will reset themselves when this data transfer has returned to normal.

The messages listed above can only be displayed if the ignition key is in position **II** (or if the engine is running) and if BLIS is active (i.e. if the system has not been turned off by pressing the **BLIS** button).



General information.....	178
Tire inflation	181
Tire inflation pressure table.....	183
Tire designations.....	184
Glossary of tire terminology.....	186
Vehicle loading.....	187
Uniform Tire Quality Grading.....	189
Snow chains, snow tires, studded tires.....	190
Temporary spare.....	191
Tire Sealing System	192
Changing wheels.....	198
Tire Pressure Monitoring System (TPMS).....	203

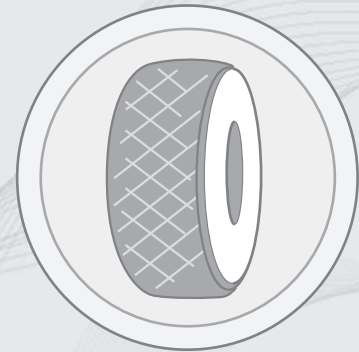

07

WHEELS AND TIRES

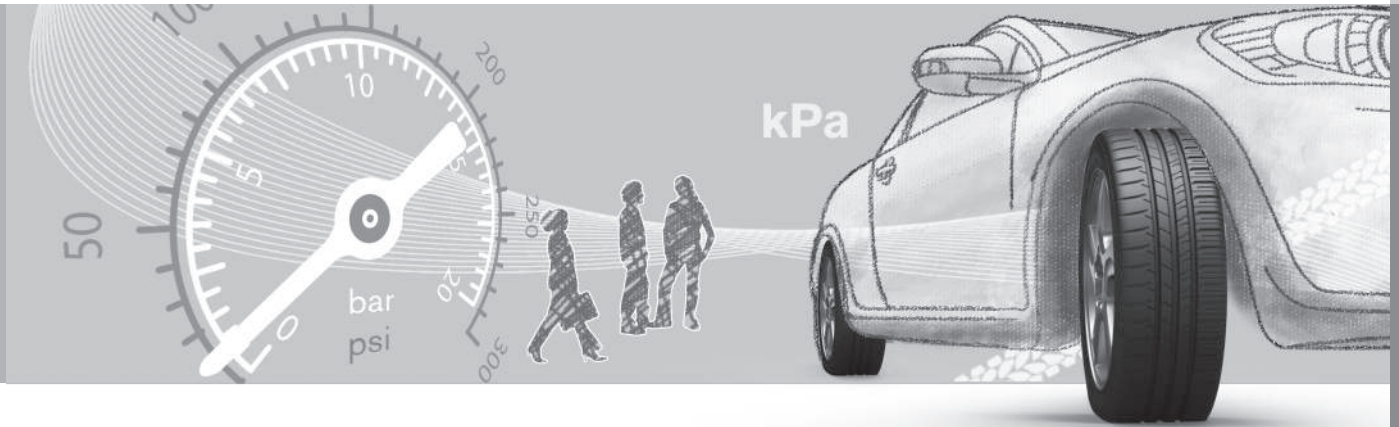



General information

Introduction

Your vehicle is equipped with tires according to the vehicle's tire information placard on the B-pillar (the structural member at the side of the vehicle, at the rear of the driver's door opening).

CAUTION

Some Volvo models are equipped with an Ultra High Performance tire and wheel combination designed to provide maximum dry pavement performance with consideration for hydroplaning resistance. They may be more susceptible to road hazard damage and, depending on driving conditions, may achieve a tread life of less than 20,000 miles (30,000 km). Even if this vehicle is equipped with Volvo's advanced AWD or DSTC system, these tires are not designed for winter driving, and should be replaced with winter tires when weather conditions dictate.

The tires have good road holding characteristics and offer good handling on dry and wet surfaces. It should be noted however that the tires have been developed to give these features on snow/ice-free surfaces.

Most models are equipped with "all-season" tires, which provide a somewhat higher degree of road holding on slippery surfaces

than tires without the "all-season" rating. However, for optimum road holding on icy or snow-covered roads, we recommend suitable winter tires on all four wheels.

When replacing tires, be sure that the new tires are the same size designation, type (radial) and preferably from the same manufacturer, on all four wheels. Otherwise there is a risk of altering the car's roadholding and handling characteristics.

New Tires

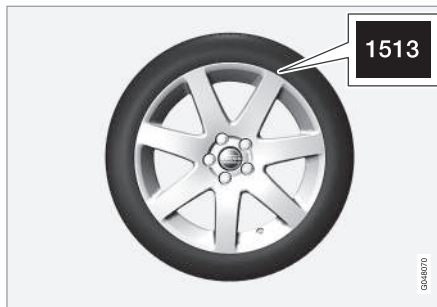

Remember that tires are perishable goods. As of 2000, the manufacturing week and year (Department of Transportation (DOT) stamp) will be indicated with 4 digits (e.g., 1513 means that the tire illustrated was manufactured during week 15 of 2013).

Tire rotation

Your vehicle has no required tire rotation. Tire wear is affected by a number of factors such as tire inflation, ambient temperature, driving style, etc.

NOTE

- If the tires are rotated, they should only be moved from front to rear or vice versa. They should never be rotated left to right/right to left.
- Ideally, tire rotation should be done the first time after approximately 3,000 miles (5,000 km) and thereafter at 6,000-mile (10,000-km) intervals. Some customers find that tire rotation may help to get extra mileage from tire life.
- Tire rotation should only be performed if front/rear tire wear is fairly even and tread height is above 1/16" (1.6 mm).

Your Volvo retailer can also provide guidance based on your particular driving circumstances.

Tire age

Tires degrade over time, even when they are not being used. It is recommended that tires generally be replaced after 6 years of normal service. Heat caused by hot climates, fre-



General information

quent high loading conditions or Ultra Violet (U.V) exposure can accelerate the aging process. The temporary spare¹ should also be replaced at 6-year intervals, even if it has never been used.

A tire's age can be determined by the DOT stamp on the sidewall (see the illustration).

A tire with e.g., visible cracks or discoloration should be replaced immediately.

Tread wear indicator

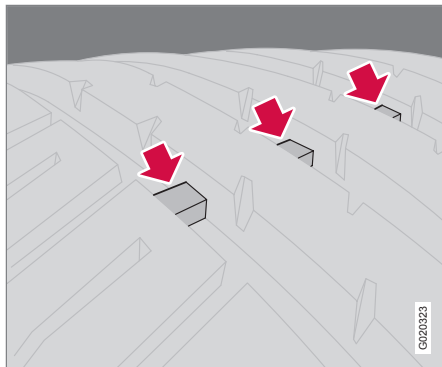

The tires have wear indicator strips running across or parallel to the tread. The letters **TWI** are printed on the side of the tire. When

approximately 1/16" (1.6 mm) is left on the tread, these strips become visible and indicate that the tire should be replaced. Tires with less than 1/16" (1.6 mm) tread offer very poor traction.

When replacing worn tires, it is recommended that the tire be identical in type (radial) and size as the one being replaced. Using a tire of the same make (manufacturer) will prevent alteration of the driving characteristics of the vehicle.

Improving tire economy

- Maintain correct tire pressure (see the inflation pressure table on page 183).
- Drive smoothly: avoid fast starts, hard braking and tire screeching.
- Tire wear increases with speed.
- Correct front wheel alignment is very important.
- Unbalanced wheels impair tire economy and driving comfort.
- Tires must maintain the same direction of rotation throughout their lifetime.
- When replacing tires, the tires with the most tread should be mounted on the rear wheels to reduce the chance of oversteer during hard braking.

- Hitting curbs or potholes can damage the tires and/or wheels permanently.

Summer and winter tires

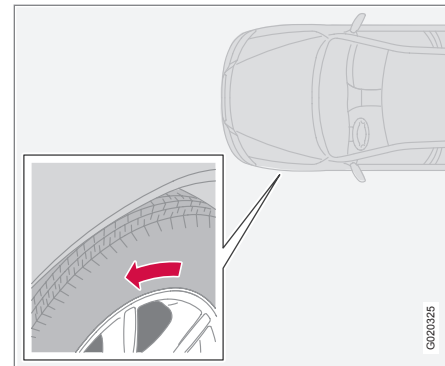

The arrows shows the direction of rotation of the tire

- When switching between summer and winter tires, mark the tires to indicate where they were mounted on the car, e.g., LF = left front, RR = right rear
- Tires with tread designed to roll in only one direction are marked with an arrow on the sidewall.

¹ Option or accessory on some models



General information

- Incorrectly mounted tires impair the car's braking properties and ability to force aside rain, snow and slush.
- The tires with the most tread should always be at the rear (to reduce the risk of skidding).
- Contact a Volvo workshop if you are unsure about the tread depth.

Storing wheels and tires

When storing complete wheels (tires mounted on rims), they should be suspended off the floor or placed on their sides on the floor.

Tires not mounted on rims should be stored on their sides or standing upright, but should not be suspended.

CAUTION

Tires should preferably be stored in a cool, dry, dark place, and should never be stored in close proximity to solvents, gasoline, oils, etc.

WARNING

- The wheel and tire sizes for your Volvo are specified to meet stringent stability and handling requirements. Unapproved wheel/tire size combinations can negatively affect your vehicle's stability and handling.
- Any damage caused by installation of unapproved wheel/tire size combinations will not be covered by your new vehicle warranty. Volvo assumes no responsibility for death, injury, or expenses that may result from such installations.



Tire inflation

Inflation placard

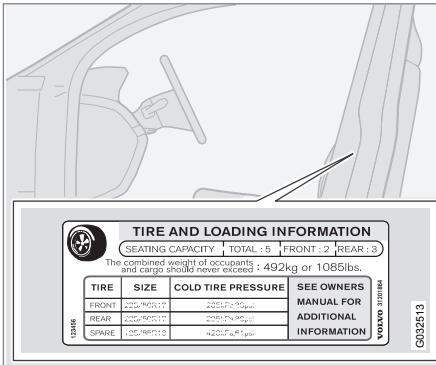

Tire inflation placard

Check tire inflation pressure regularly.

A table listing the recommended inflation pressure for your vehicle can be found on page 183. A tire inflation pressure placard is also located on the driver's side B-pillar (the structural member at the side of the vehicle, at the rear of the driver's door opening). This placard indicates the designation of the factory-mounted tires on your vehicle, as well as load limits and inflation pressure.

NOTE

The placards shown indicate inflation pressure for the tires installed on the vehicle at the factory only.

- Use a tire gauge to check the tire inflation pressure, including the spare, at least once a month and before long trips. You are strongly urged to buy a reliable tire pressure gauge, as automatic service station gauges may be inaccurate.
- Use the recommended cold inflation pressure for optimum tire performance and wear.
- Under-inflation or over-inflation may cause uneven treadwear patterns.

WARNING

- Under-inflation is the most common cause of tire failure and may result in severe tire cracking, tread separation, or "blow-out," with unexpected loss of vehicle control and increased risk of injury.
- Under-inflated tires reduce the load carrying capacity of your vehicle.

When weather temperature changes occur, tire inflation pressures also change. A 10-

degree temperature drop causes a corresponding drop of 1 psi (7 kPa) in inflation pressure. Check your tire pressures frequently and adjust them to the proper pressure, which can be found on the vehicle's tire information placard or certification label.

Checking tire pressure

A certain amount of air seepage from the tires occurs naturally and tire pressure fluctuates with seasonal changes in temperature. Always check tire pressure regularly.

Cold tires

Inflation pressure should be checked when the tires are cold.

The tires are considered to be cold when they have the same temperature as the surrounding (ambient) air.

This temperature is normally reached after the vehicle has been parked for at least 3 hours.

After driving a distance of approximately 1 mile (1.6 km), the tires are considered to be hot. If you have to drive farther than this distance to pump your tire(s), check and record the tire pressure first and add the appropriate air pressure when you get to the pump.

If checking tire pressure when the tire is hot, never "bleed" or reduce air pressure. The tires are hot from driving and it is normal for pressures to increase above recommended



Tire inflation

cold pressures. A hot tire at or below recommended cold inflation pressure could be significantly under-inflated.

To check inflation pressure:

1. Remove the cap from the valve on one tire, then firmly press the tire gauge onto the valve.
2. Add air to reach the recommended air pressure.
3. Reinstall the valve cap.

CAUTION

- After pumping the tires, always reinstall the valve cap to help avoid damage to the valve from dirt, gravel, etc.
- Use plastic valve caps only. Metal caps could corrode and become difficult to remove.

4. Visually inspect the tires to make sure there are no nails or other objects embedded that could puncture the tire and cause an air leak.
5. Check the sidewalls to make sure there are no gouges, cuts, bulges or other irregularities.

6. Repeat this procedure for each tire, including the spare.

NOTE

- If you overfill the tire, release air by pushing on the metal stem in the center of the valve. Then recheck the pressure with your tire gauge.
- Some spare tires require higher inflation pressure than the other tires. Consult the tire inflation pressure table on page 183 or see the inflation pressure placard.

Speed ratings

The speed ratings in the table translate as follows:

Speed ratings	
M	81 mph (130 km/h)
Q	100 mph (160 km/h)
T	118 mph (190 km/h)
H	130 mph (210 km/h)
V	149 mph (240 km/h)

Speed ratings

W	168 mph (270 km/h)
Y	186 mph (300 km/h)

Load ratings

See page 184 for an explanation of the load rating on the sidewall of the tire.



Tire inflation pressure table

The following tire pressures are recommended by Volvo for your vehicle. Refer to

the tire inflation placard (see page 181 for its location) for information specific to the tires installed on your vehicle at the factory.

Tire size	Cold tire pressure up to five persons psi (kPa)	
	Front psi (kPa)	Rear psi (kPa)
235/65 R17	36 (250)	36 (250)
235/60 R18		
255/50 R19		
255/45 R20		
Temporary spare tire T125/80R17	61 (420)	61 (420)

i NOTE

Please consult a Volvo retailer's Parts department for the most up-to-date specifications.



Tire designations

- ⑩ **Maximum Load:** Indicates the maximum load in pounds and kilograms that can be carried by the tire. Refer to the vehicle's tire information placard located on the B-Pillar or the driver's door for the correct tire pressure for your vehicle.
- ⑪ **Treadwear, Traction, and Temperature grades:** see page 189 for more information.
- ⑫ **Maximum permissible inflation pressure:** the greatest amount of air pressure that should ever be put in the tire. This limit is set by the tire manufacturer.

Tire suppliers may have additional markings, notes or warnings such as standard load, radial tubeless, etc.



Glossary of tire terminology

- **Tire information placard:** A placard showing the OE (Original Equipment) tire sizes, recommended inflation pressure, and the maximum weight the vehicle can carry.
- **Tire Identification Number (TIN):** A number on the sidewall of each tire providing information about the tire brand and manufacturing plant, tire size and date of manufacturer.
- **Inflation pressure:** A measure of the amount of air in a tire.
- **Standard load:** A class of P-metric or Metric tires designed to carry a maximum load at 35 psi [37 psi (2.5 bar) for Metric tires]. Increasing the inflation pressure beyond this pressure will not increase the tires load carrying capability.
- **Extra load:** A class of P-metric or Metric tires designed to carry a heavier maximum load at 41 psi [43 psi (2.9 bar) for Metric tires]. Increasing the inflation pressure beyond this pressure will not increase the tires load carrying capability.
- **kPa:** Kilopascal, a metric unit of air pressure.
- **PSI:** Pounds per square inch, a standard unit of air pressure.
- **B-pillar:** The structural member at the side of the vehicle behind the front door.
- **Bead area of the tire:** Area of the tire next to the rim.
- **Sidewall of the tire:** Area between the bead area and the tread.
- **Tread area of the tire:** Area of the perimeter of the tire that contacts the road when mounted on the vehicle.
- **Rim:** The metal support (wheel) for a tire or a tire and tube assembly upon which the tire beads are seated.
- **Maximum load rating:** a figure indicating the maximum load in pounds and kilograms that can be carried by the tire. This rating is established by the tire manufacturer.
- **Maximum permissible inflation pressure:** the greatest amount of air pressure that should ever be put in the tire. This limit is set by the tire manufacturer.
- **Recommended tire inflation pressure:** inflation pressure, established by Volvo, which is based on the type of tires that are mounted on a vehicle at the factory. This information can be found on the tire inflation placard(s) located on the driver's side B-pillar and in the tire inflation table in this chapter.
- **Cold tires:** The tires are considered to be cold when they have the same temperature as the surrounding (ambient) air. This temperature is normally reached after the vehicle has been parked for at least 3 hours.



Vehicle loading

Properly loading your vehicle will provide maximum return of vehicle design performance.

Before loading your vehicle, familiarize yourself with the following terms for determining your vehicle's weight ratings, with or without a trailer, from the vehicle's Federal/ Canadian Motor Vehicle Safety Standards (FMVSS/ CMVSS) label, and the vehicle's tire information placard.

Curb weight

The weight of the vehicle including a full tank of fuel and all standard equipment. It does not include passengers, cargo, or optional equipment.

Capacity weight

All weight added to the curb weight, including cargo and optional equipment. When towing, trailer hitch tongue load is also part of cargo weight.



NOTE

For trailer towing information, please refer to the section "Towing a trailer."

Permissible axle weight

The maximum allowable weight that can be carried by a single axle (front or rear). These numbers are shown on the Federal/Canadian Motor Vehicle Safety Standards (FMVSS/ CMVSS) label. The total load on each axle must never exceed its maximum permissible weight.

Gross vehicle weight (GVW)

The vehicle's curb weight + cargo + passengers.

A table listing important weight limits for your vehicle, is in chapter "Dimension and weights".

For the location of the various labels in your vehicle, see page 282

Steps for Determining Correct Load Limit

- Locate the statement "the combined weight of occupants and cargo should never exceed XXX pounds" on your vehicle's placard.
- Determine the combined weight of the driver and passengers that will be riding in your vehicle.
- Subtract the combined weight of the driver and passengers from XXX kilograms or XXX pounds.
- The resulting figure equals the available amount of cargo and luggage load capacity. For example, if the "XXX" amount equals 1400 lbs. and there will be five 150 lb. passengers in your vehicle, the amount of available cargo and luggage load capacity is 650 lbs. (1400-750 (5 x 150) = 650 lbs.)
- Determine the combined weight of luggage and cargo being loaded on the vehicle. That weight may not safely exceed the available cargo and luggage load capacity calculated in Step 4.
- If your vehicle will be towing a trailer, load from your trailer will be transferred to your vehicle. Consult this manual¹ to determine how this reduces the available cargo and luggage load capacity of your vehicle.

¹ For "Towing a trailer" see page 164.



Vehicle loading

WARNING

- Exceeding the permissible axle weight, gross vehicle weight, or any other weight rating limits can cause tire overheating resulting in permanent deformation or catastrophic failure.
- Do not use replacement tires with lower load carrying capacities than the tires that were original equipment on the vehicle because this will lower the vehicle's GVW rating. Use only tires with the correct load carrying capacity. Consult your Volvo retailer for information.



Uniform Tire Quality Grading

ALL PASSENGER VEHICLE TIRES MUST CONFORM TO FEDERAL SAFETY REQUIREMENTS IN ADDITION TO THESE GRADES

Quality grades can be found, where applicable, on the tire sidewall between the tread shoulder and maximum section width. For example:

Treadwear 200 Traction AA Temperature A

TREADWEAR

The treadwear grade is a comparative rating based on the wear rate of the tire when tested under controlled conditions on a specified government test course. For example, a tire graded 150 would wear one and one half (1 1/2) times as well on the government course as a tire graded 100. The relative performance of tires depends upon the actual conditions of their use, however, and many depart significantly from the norm due to variation in driving habits, maintenance practices and differences in road characteristics and climate.

TRACTION

The traction grades, from highest to lowest, are AA, A, B, and C, as measured under controlled conditions on specified government test surfaces of asphalt and concrete. A tire marked C may have poor traction performance.

WARNING

The traction grade assigned to this tire is based on braking (straight-ahead) traction tests and is not a measure of cornering (turning) traction.

TEMPERATURE

The temperature grades are A (the highest), B, and C, representing the tire's resistance to the generation of heat and its ability to dissipate heat when tested under controlled conditions on a specified indoor laboratory test wheel. Sustained high temperature can cause the material of the tire to degenerate and reduce tire life, and excessive temperature can lead to sudden tire failure. The grade C corresponds to a minimum level of performance that all passenger vehicle tires must meet under the Federal Motor Safety Standard No. 109. Grades B and A represent higher levels of performance on the laboratory test wheel than the minimum required by law.

WARNING

The temperature grade for this tire is established for a tire that is properly inflated and not overloaded. Excessive speed, under-inflation, or excessive loading, either separately or in combination, can cause heat buildup and tire failure.



Snow chains, snow tires, studded tires

Snow chains

Snow chains can be used on your Volvo with the following restrictions:

- Snow chains should be installed on front wheels only. Use only Volvo approved snow chains.
- If accessory, aftermarket or "custom" tires and wheels are installed and are of a size different than the original tires and wheels, chains in some cases CANNOT be used. Sufficient clearances between chains and brakes, suspension and body components must be maintained.
- Some strap-on type chains will interfere with brake components and therefore CANNOT be used.
- All Wheel Drive models: Snow chains should only be installed on the front wheels.
- Certain size tires may not allow the assembly of snow chains/traction devices.

Consult your Volvo retailer for additional snow chain information.



CAUTION

- Check local regulations regarding the use of snow chains before installing.
- Always follow the chain manufacturer's installation instructions carefully. Install chains as tightly as possible and retighten periodically.
- Never exceed the chain manufacturer's specified maximum speed limit. (Under no circumstances should you exceed 31 mph (50 km/h)).
- Avoid bumps, holes or sharp turns when driving with snow chains.
- The handling of the vehicle can be adversely affected when driving with chains. Avoid fast or sharp turns as well as locked wheel braking.

Snow tires, studded tires¹

Tires for winter use:

- Owners who live in or regularly commute through areas with sustained periods of snow or icy driving conditions are strongly advised to fit suitable winter tires

to help retain the highest degree of traction.

- It is important to install winter tires on all four wheels to help retain traction during cornering, braking, and accelerating. Failure to do so could reduce traction to an unsafe level or adversely affect handling.
- Do not mix tires of different design as this could also negatively affect overall tire road grip.
- Winter tires wear more quickly on dry roads in warm weather. They should be removed when the winter driving season has ended.
- Studded tires should be run-in 300-600 miles (500-1000 km) during which the vehicle should be driven as smoothly as possible to give the studs the opportunity to seat properly in the tires. The tires should have the same rotational direction throughout their entire lifetime.



NOTE

Please consult state or provincial regulations restricting the use of studded winter tires before installing such tires.

¹ Where permitted

**Temporary spare**

The spare tire in your vehicle¹ is called a "Temporary Spare".

Recommended tire pressure (see the placard on the B-pillar or on the fuel filler door) should be maintained irrespective of which position on the vehicle the temporary spare tire is used.

In the event of damage to this tire, a new one can be purchased from your Volvo retailer.

**WARNING**

Current legislation prohibits the use of the "Temporary Spare" tire other than as a temporary replacement for a punctured tire. It must be replaced as soon as possible by a standard tire. Road holding and handling may be affected with the "Temporary Spare" in use. Do not exceed 50 mph (80 km/h).

**CAUTION**

The vehicle must not be driven with wheels of different dimensions or with a spare tire other than the one that came with the vehicle. The use of different size wheels can seriously damage your vehicle's transmission.

¹ Not on models equipped with the Tire sealing system.



Tire Sealing System

Introduction

Certain models are equipped with a tire sealing system* that enables you to temporarily seal a hole in the tread surface and re-inflate a flat tire, or to adjust a tire's inflation pressure.

The system consists of an air compressor, a container for the sealing compound, wiring to connect the system to the vehicle's electrical system via one of the 12-volt sockets, and a hose used to connect the system to the tire's inflation valve.

NOTE

The tire sealing system's compressor has been tested and approved by Volvo.

The 12-volt sockets are located on the rear side of the center console (in the rear seat) and in the cargo area.

Accessing the tire sealing system

The tire sealing system is stowed under the floor of the cargo area. To access it:

1. Fold up or remove any protective floor covering or carpet.
2. Open the floor hatch.
3. Lift out the tire sealing system.

NOTE

- The tire sealing system is only intended to seal holes on the tire's tread area, not the sidewall.
- Tires with large holes or tears cannot be repaired with the tire sealing system.
- After use, stow the tire sealing system properly to help prevent rattling.

WARNING

- After using the tire sealing system, the vehicle should not be driven farther than approximately 120 miles (200 km).
- Have the tire inspected by a trained and qualified Volvo service technician as soon as possible to determine if it can be permanently repaired or must be replaced.
- The vehicle should not be driven faster than 50 mph (80 km/h) while using a tire that has been temporarily repaired with the tire sealing system.
- After using the tire sealing system, drive carefully and avoid abrupt steering maneuvers and sudden stops.

Tire sealing system—overview

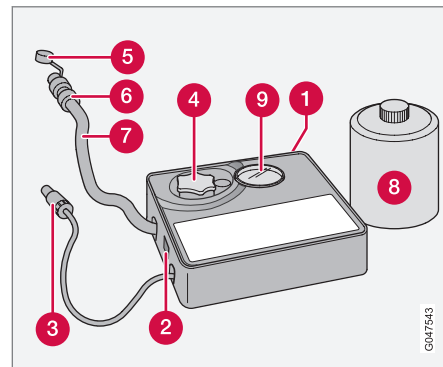

- 1 Speed limit sticker (on the rear side of the compressor)
- 2 On/Off switch
- 3 Electrical wire
- 4 Bottle holder (orange cover)
- 5 Protective hose cover
- 6 Air pressure release knob
- 7 Hose
- 8 Bottle with sealing compound
- 9 Air pressure gauge



Tire Sealing System

! WARNING

Please keep the following points in mind when using the tire sealing system:

- The sealing compound bottle (no. 8 in the illustration) contains 1) rubber latex, natural and 2) ethanediol. These substances are harmful if swallowed.
- The contents of this bottle may cause allergic skin reactions or otherwise be potentially harmful to the respiratory tract, the skin, the central nervous system, and the eyes.

Precautions:

- Keep out of reach of children.
- Do not ingest the contents.
- Avoid prolonged or repeated contact with the skin.
- Wash thoroughly after handling.

First aid:

- Skin: Wash affected areas of skin with soap and water. Get medical attention if symptoms occur.
- Eyes: Flush with plenty of water for least 15 minutes, occasionally lifting the upper and lower eyelids. Get medical attention if symptoms occur.

- Inhalation: Move the exposed person to fresh air. If irritation persists, get medical attention.
- Ingestion: Do **NOT** induce vomiting unless directed to do so by medical personnel. Get medical attention.
- Disposal: Dispose of this material and its container to a hazardous or special waste collection point.

i NOTE

Do not break the seal on the bottle. This occurs automatically when the bottle is screwed into the holder.

Tire sealing system—temporarily repairing a flat tire

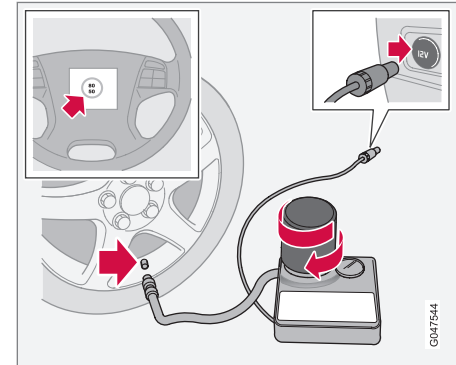

Temporarily repairing a flat tire is done in two stages:

- **Stage 1:** The hole is sealed by pumping sealing compound into the tire. The car is then driven a short distance to distribute the sealing compound in the tire.

i NOTE

Do not remove any foreign objects (nails, etc.) from the tire before using the sealing system.

- **Stage 2:** The tire's inflation pressure is checked and adjusted if necessary.



Tire Sealing System

WARNING

- Never leave the tire sealing system unattended when it is operating.
- Keep the tire sealing system away from children.
- Be sure the vehicle is parked safely off the road and away from moving traffic.
- Apply the parking brake.

Stage 1: Sealing the hole

1. Peel off the speed limit sticker and affix it to the steering wheel hub where it will be clearly visible to the driver.
2. Ensure that the on/off switch is in position **0** (the **0** side of the switch should be pressed down).
3. Put on the gloves included in the tire sealing system.

WARNING

Contact with the sealing compound may cause skin irritation. If contact occurs, wash the affected area immediately with soap and water.

4. Unscrew the orange cover over the bottle holder and unscrew the cap on the bottle of sealing compound.

NOTE

Do not break the seal on the bottle. This occurs automatically when the bottle is screwed into the holder.

5. Screw the bottle into the bottle holder.

WARNING

The bottle is equipped with a catch to keep it securely in place and help prevent sealing compound leakage. Once in place, the bottle cannot be unscrewed. This must be done by a trained and qualified Volvo service technician.

6. Remove the valve cap from the tire's inflation valve and screw the tire sealing system's hose connector onto the valve as tightly as possible by hand.
7. Connect the electrical wire to the nearest 12-volt socket in the vehicle.

NOTE

Be sure that none of the other 12-volt sockets is being used while the compressor is in operation.

8. Start the vehicle's engine.
9. Start the tire sealing system's compressor by pressing the on/off switch to position **I**.

WARNING

- Never stand next to the tire being inflated when the compressor is in operation.
- If cracks, bubbles, etc. form on the tire, switch off the compressor immediately.
- If there is visible damage to the sidewall or the rim, the tire cannot be repaired. The vehicle should not be driven if this occurs. Contact a towing service or Volvo On Call Roadside Assistance if applicable.



Tire Sealing System

NOTE

The air pressure gauge will temporarily show an increase in pressure to approximately 88 psi (6 bar) while the sealing compound is being pumped into the tire. The pressure should return to a normal level after approximately 30 seconds.

10. Within seven minutes, inflate the tire to between 22–44 psi (1.8–3.0 bar). Switch off the compressor briefly to get a clear reading from the pressure gauge.

CAUTION

The compressor should not be used for more than 10 minutes at a time to avoid overheating.

WARNING

If the pressure remains below 22 psi (1.8 bar) after approximately seven minutes, turn off the compressor. In this case, the hole is too large to be sealed and the vehicle should not be driven.

11. Switch off the compressor and disconnect the electrical wire from the 12-volt socket.

12. Unscrew the hose from the tire's inflation valve and reinstall the valve cap.

CAUTION

- After pumping the tires, always reinstall the valve cap to help avoid damage to the valve from dirt, gravel, etc.
- Use plastic valve caps only. Metal caps could corrode and become difficult to remove.

13. Immediately drive the vehicle for approximately 2 miles (3 km) at a maximum speed of 50 mph (80 km/h) to distribute the sealing compound in the tire.

CAUTION

If your vehicle is equipped with the Tire Pressure Monitoring System (TPMS), the use of the sealing compound may lead to incorrect tire pressure readings or in rare cases, damage to the tire pressure sensor. Use the tire sealing system to check and adjust the damaged tire's inflation pressure.

NOTE

- Safely stow the tire sealing system in a convenient place as it will soon be used again to check the tire's inflation pressure.
- The empty bottle of sealing compound cannot be removed from the bottle holder. Consult a trained and qualified Volvo service technician to have the bottle removed and properly disposed of.

WARNING

If heavy vibrations, unsteady steering behavior, or noises should occur while driving, reduce speed and park the vehicle in a safe place. Recheck the tire for bumps, cracks, or other visible damage, and recheck its inflation pressure. If the pressure is below 19 psi (1.3 bar), do not continue driving. Have the vehicle towed to a trained and qualified Volvo service technician.

Stage 2: Checking inflation pressure

1. Connect the tire sealing system as described in **stage 1**.
2. Refer to the inflation pressure tables for the correct inflation pressure. If the tire needs to be inflated, start the tire sealing



Tire Sealing System

system's compressor. If necessary, release air from the tire by turning the air release knob counterclockwise.

CAUTION

The compressor should not be used for more than 10 minutes at a time to avoid overheating.

WARNING

If you interrupt your trip for more than 1 hour, check the inflation pressure in the damaged tire again before continuing.

Replacing the sealing compound container

The sealing compound container must be replaced if:

- the tire sealing system has been used to repair a tire
- the container's expiration date has passed (see the date on decal).

NOTE

- After use, the sealing compound bottle, the hose, and certain other system components must be replaced. Please consult your Volvo retailer for replacement parts.
- If the sealing compound bottle's expiration date has passed, please take it to a Volvo retailer or a recycling station that can properly dispose of harmful substances.

Inflating tires

The tire sealing system can be used to inflate the tires. To do so:

1. Park the car in a safe place.
2. The compressor should be switched off. Ensure that the on/off switch is in position **0** (the **0** side of the switch should be pressed down).
3. Take out the electrical wire and hose.
4. Remove the valve cap from the tire's inflation valve and screw the hose connector onto the valve as tightly as possible by hand.
5. Connect the electrical wire to the nearest 12-volt socket in the vehicle.

6. Start the vehicle's engine.

WARNING

- The vehicle's engine should be running when the tire sealing system is used to avoid battery drain. Therefore, be sure the vehicle is parked in a well ventilated place, or outdoors, before using the system. The parking brake should be securely applied and the gear selector should be in the **P** (park) position.
- Children should never be left unattended in the vehicle when the engine is running.

7. Check the tire's inflation pressure on the gauge. Switch off the compressor briefly to get a clear reading from the pressure gauge.
8. Refer to the tire inflation tables for the correct inflation pressure. If the tire needs to be inflated, start the tire sealing system's compressor (press the on/off switch to position I). If necessary, release air from the tire by turning the air release knob counterclockwise.

**Tire Sealing System****! CAUTION**

The compressor should not be used for more than 10 minutes at a time to avoid overheating.

9. Turn off the compressor (press the on/off switch to position **0**) when the correct inflation pressure has been reached.
10. Unscrew the hose from the tire's inflation valve and reinstall the valve cap.

! CAUTION

- After pumping the tires, always reinstall the valve cap to help avoid damage to the valve from dirt, gravel, etc.
- Use plastic valve caps only. Metal caps could corrode and become difficult to remove.

11. Disconnect the electrical wire from the 12-volt socket.



Changing wheels

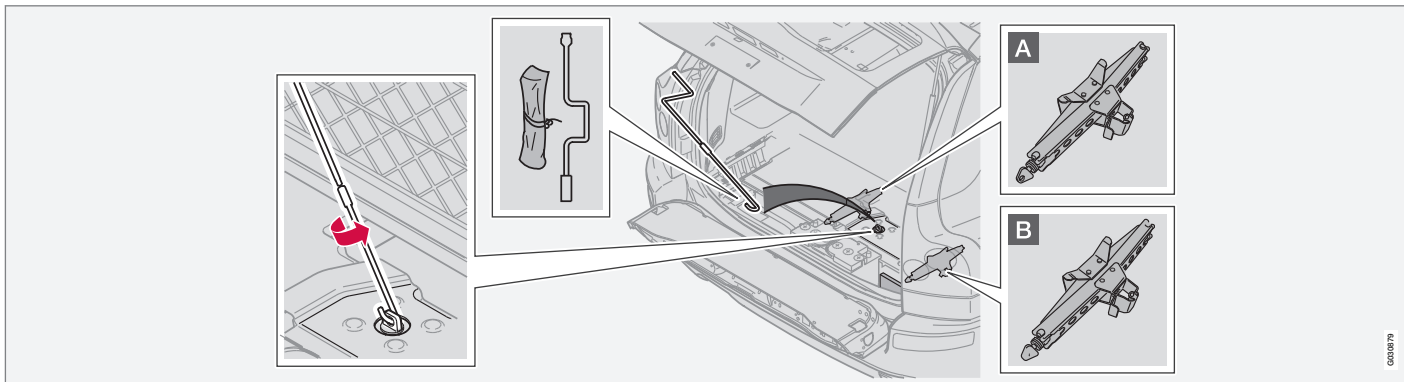

Jack location

Changing wheels

Location of the jack

The jack is located in the center under the rear hatch in the cargo area floor. Lift this hatch and release the retaining strap to slide out the jack.

The rear section of the jack's crank and the tool bag are stowed in the foam block. The front (hook) section of the crank is stored in the tool bag.

The rear section of the crank is stored in the foam block.

If the vehicle is equipped with the optional grocery bag holder, fold up the rear section of the cargo area floor, disconnect the grocery bag holder's retaining cords and fold up the lower section of the floor.

i NOTE

The rear section of the crank is enclosed in a protective sleeve that should be slid off before the crank is used. We recommend reinserting the crank into this sleeve before the crank is stowed.

! CAUTION

Seven-seat models: Do not store objects in the area for the rear seat cushions (when the backrests are to be folded down). This could damage the cushions.

Lowering the spare wheel

The spare wheel is located under the floor of the rear cargo compartment. It can be lowered using the crank.

0620079



Changing wheels

WARNING

When raising or lowering the spare wheel, please keep in mind that components in the exhaust system may be very hot.

To lower the spare wheel:

1. Fold down the lower section of the tail-gate.
2. Fold up the rear section of the floor in the cargo compartment.
3. Connect the two sections of the jack's crank.
4. Insert the hooked end of the crank in the spare wheel retaining attachment.
5. Lower the spare wheel under the vehicle by turning the crank counterclockwise until it is not possible to turn it further.
6. Pivot the toggle at the end of the cable 90 degrees to release it from the spare wheel

CAUTION

When the spare wheel is mounted on the vehicle, the retaining cable could damage the underside of the vehicle if it is not retracted.

7. Crank up the cable again by turning the crank clockwise.
8. Place the wheel with the flat tire in the vehicle's cargo compartment.

NOTE

The space under the vehicle is designed to hold the special spare wheel only. Other full-size wheels will not fit in this compartment.

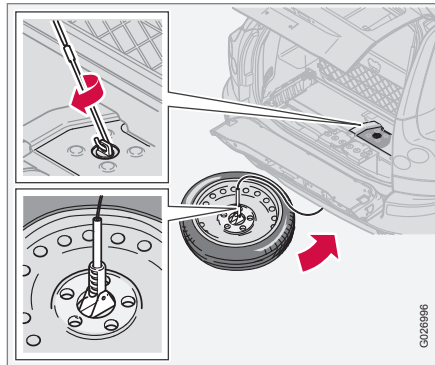

Returning the spare wheel to the storage compartment

1. Use the crank (turn it counterclockwise) to lower the spare wheel's retaining cable.
2. Pass the toggle at the end of the cable through the center hole in the spare wheel. Pivot the toggle 90 degrees so that when raised, the wheel will rest on the toggle.
3. Retract the retaining cable slightly by slowly turning the crank clockwise several times.
4. Position the wheel so that it is not obstructed by components in the exhaust system.
5. Continue to raise the wheel by turning the crank clockwise. Raise the wheel a little bit at a time and guide it around the rear axle until it is securely seated in the storage area.
6. When it is no longer possible to turn the crank any further, check that the spare wheel is securely in position in the storage compartment.



Changing wheels

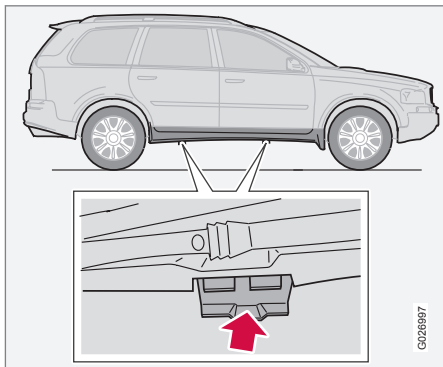

Jack attachment points

Jack attachments

There are two attachment points for the jack on each side of the vehicle. These attachment points are under the center of each door.

! WARNING

There is an attachment point on each side of the vehicle located under the pillars between the front and rear doors. This point is used during the production process only, and is NOT intended for attaching the jack.

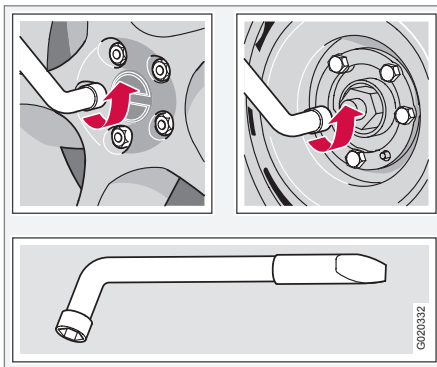

! WARNING

The undersides of accessory running boards are not intended for attaching the jack.

Changing a wheel

1. Park the vehicle on a firm, level, non-slippery surface.
2. Engage the parking brake and put the gear selector in the Park position.
3. Loosen the wheel bolts by exerting downward pressure on the lug wrench.

4. Remove the wheel cover (where applicable) using the lug wrench in the tool bag.
5. With the wheels still on the ground, use the lug wrench to loosen the wheel bolts $\frac{1}{2}$ – 1 turn. Turn the bolts counterclockwise to loosen the bolts.

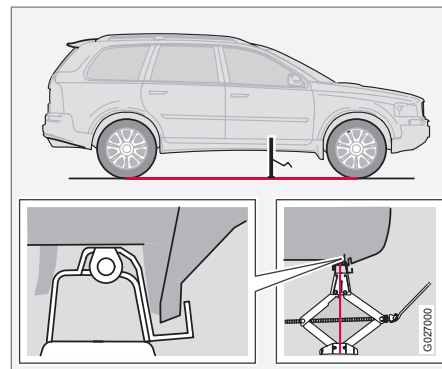

Attaching the jack

6. Place the jack on the ground, under one of the attachment points (see the illustration) and crank while simultaneously guiding the jack's attachment bracket onto the attachment point (see illustration) The base of the jack must be flat on a level, firm, non-slippery surface. Before raising



Changing wheels

the vehicle, check that the jack is still correctly positioned in the attachment.

7. Raise the vehicle until the wheel to be changed is lifted off the ground.
8. Unscrew the wheel bolts completely and carefully remove the wheel so as not to damage the threads on the studs.

 **NOTE**

To avoid excessive wear and the necessity of rebalancing, mark and reinstall wheels in the same location and position as before removal. To lessen the chance of imbalance, each wheel hub is equipped with a guide stud to ensure that a removed wheel can be reinstalled in its original position (as when changing over to winter tires/wheels).

 **CAUTION**

- The vehicle must not be driven with wheels of different dimensions or with a spare tire other than the one that came with the vehicle. The use of different size wheels can seriously damage your vehicle's transmission.
- Correct tightening torque on wheel bolts must be observed.
- The wheel bolts should never be greased or lubricated.
- Extended, chromed wheel bolts must not be used with steel rims, as they make it impossible to fit the hub caps.

Installing the wheel

1. Clean the contact surfaces on the wheel and hub.
2. Lift the wheel and place it on the hub.
3. Install the wheel bolts and tighten hand-tight. Using the lug wrench, tighten crosswise until all bolts are snug.
4. Lower the vehicle to the ground and alternately tighten the bolts crosswise to 103 ft.lbs. (140 Nm).
5. Install the wheel cover (where applicable).

 **WARNING**

- The jack must correctly engage the bar in the jack attachment. The vehicle's weight must not rest on the jack attachment. See illustration "Attaching the jack" on the previous page.
- Be sure the jack is on a firm, level, non-slippery surface.
- Never allow any part of your body to be extended under a vehicle supported by a jack.
- Use the jack intended for the vehicle when replacing a wheel. For any other job, use stands to support the side of the vehicle being worked on.
- Apply the parking brake and put the gear selector in the (P)ark position.
- Block the wheels standing on the ground, use rigid wooden blocks or large stones.
- The jack should be kept well-greased and clean, and should not be damaged.
- No objects should be placed between the base of jack and the ground, or between the jack and the attachment bar on the vehicle.



Changing wheels



NOTE

The jack provided with your vehicle is intended to be used only in temporary situations such as changing wheels in the event of a flat tire. Only the jack that came with your particular model should be used to lift the vehicle. If the vehicle needs to be lifted more frequently or for a prolonged period, using a garage jack or hoist is recommended. Always follow this device's instructions for use.

The jack and tools should be returned to their storage spaces. The jack should be cranked down fully so that it fits into the intended space.



Tire Pressure Monitoring System (TPMS)

The tire pressure monitoring system¹ uses sensors mounted in the tire valves to check inflation pressure levels. When the vehicle is moving at a speed of approximately 20 mph (30 km/h) or faster, these sensors transmit inflation pressure data to a receiver located in the vehicle.

USA – FCC ID: MRXG403MA4^A

This device complies with part 15 of the FCC rules. Operation is subject to the following conditions: (1) This device may not cause harmful interference, and (2) this device must accept any interference received, including interference that may cause undesired operation.

When low inflation pressure is detected, TPMS will light up the tire pressure warning light (also referred to as a telltale) in the instrument panel (see page 61), and will display a message in the text window. The wording of this message is determined by the degree of inflation pressure loss.

^A On certain models, the FCC code is MRXTG315AM04

When low inflation pressure is detected, TPMS will light up the tire pressure warning light  (also referred to as a telltale) in the

instrument panel and will display one of the following messages in the text window: **LOW TIRE PRESS. CHECK TIRES** or **VERY LOW TIRE PRESSURE**.

NOTE

If a fault occurs in TPMS, the tire pressure warning light will flash for approximately 1 minute and **TIRE PRESS SYST SERVICE REQUIRED** will be displayed.

Each tire, including the spare (if provided), should be checked monthly when cold and inflated to the inflation pressure recommended by the vehicle manufacturer on the vehicle placard or tire inflation pressure label. (If your vehicle has tires of a different size than the size indicated on the vehicle placard or tire inflation pressure label, you should determine the proper tire inflation pressure for those tires.)

As an added safety feature, your vehicle has been equipped with a tire pressure monitoring system (TPMS) that illuminates a low tire pressure telltale when one or more of your tires is significantly under-inflated. Accordingly, when the low tire pressure telltale illuminates, you should stop and check your tires as soon as possible, and inflate them to

the proper pressure. Driving on a significantly under-inflated tire causes the tire to overheat and can lead to tire failure. Under-inflation also reduces fuel efficiency and tire tread life, and may affect the vehicle's handling and stopping ability.

Please note that the TPMS is not a substitute for proper tire maintenance, and it is the driver's responsibility to maintain correct tire pressure, even if under-inflation has not reached the level to trigger illumination of the TPMS low tire pressure telltale.

Your vehicle has also been equipped with a TPMS malfunction indicator to indicate when the system is not operating properly. The TPMS malfunction indicator is combined with the low tire pressure telltale. When the system detects a malfunction, the telltale will flash for approximately one minute and then remain continuously illuminated. This sequence will continue upon subsequent vehicle start-ups as long as the malfunction exists. When the malfunction indicator is illuminated, the system may not be able to detect or signal low tire pressure as intended. TPMS malfunctions may occur for a variety of reasons, including the installation of replacement or alternate tires or wheels on the vehicle that prevent the TPMS from functioning

¹ This system is standard on U.S. models and optional on Canadian models



Tire Pressure Monitoring System (TPMS)

properly. Always check the TPMS malfunction telltale after replacing one or more tires or wheels on your vehicle to ensure that the replacement or alternate tires and wheels allow the TPMS to continue to function properly.

NOTE

TPMS indicates low tire pressure but does not replace normal tire maintenance. For information on correct tire pressure, please refer to the tire inflation pressure table in this chapter or consult your Volvo retailer.

Erasing warning messages

When a low tire pressure warning message has been displayed, and the tire pressure warning light has come on:

1. Use a tire pressure gauge to check the inflation pressure of all four tires.
2. Re-inflate the tire(s) to the correct pressure (consult the tire pressure placard or the table see page 183).
3. Drive the vehicle for several minutes at a speed of 20 mph (30 km/h) or faster.
 - > This will erase the warning text and the warning light will go out.

WARNING

Incorrect inflation pressure could lead to tire failure, resulting in a loss of control of the vehicle.

Changing wheels with TPMS

Please note the following when changing or replacing the factory installed TPMS wheels/tires on the vehicle:

- Only the factory-mounted wheels are equipped with TPMS sensors in the valves.
- If the vehicle is equipped with a temporary spare tire, this tire does not have a TPMS sensor.
- If wheels without TPMS sensors are mounted on the vehicle, **TIRE PRESS SYST. SERVICE REQUIRED** will be displayed each time the vehicle is driven above 25 mph (40 km/h) for 10 minutes or more.
- Once TPMS sensors are properly installed, the warning message should not reappear.
- Volvo recommends that TPMS sensors be fitted on all wheels used on the vehicle. Volvo does not recommend moving sensors back and forth between sets of wheels.

NOTE

If a tire is changed or if the TPMS sensor is moved to another wheel, the sensor's valve and valve core should be replaced.

CAUTION

When inflating tires with TPMS valves, press the pump's mouthpiece straight onto the valve to help avoid bending or otherwise damaging the valve.

Recalibrating TPMS (Canadian models only)

In certain cases, it may be necessary to recalibrate TPMS to conform to Volvo's recommended tire inflation pressures (see the inflation pressure table on page 183), for example, if higher inflation pressure is necessary when transporting heavy loads, etc.

To recalibrate:

1. Switch off the engine.
2. Inflate the tires to the desired pressure and turn the ignition key to position **I** or **II** (see page 145 for additional information).
3. Turn the thumb wheel on the left-side steering wheel lever until **Tire pressure Calibration** appears in the display.



Tire Pressure Monitoring System (TPMS)

- Press and hold the **Reset** button on the left-side steering wheel lever until **TIRE PRESSURE CALIBRATED** is displayed.

Activating/deactivating TPMS

(Canadian models only)

- Switch off the engine.
- Turn the ignition key to position **I** or **II**.
- Press and hold the **Reset** button on the left-side steering wheel lever until **TIRE PRESS SYST OFF** is displayed.

Repeat steps 1-3 to turn TPMS on again.

Self-supporting run flat tires (SST)*

Self-supporting run flat tires are available as optional equipment. The vehicle must be equipped with the Tire Pressure Monitoring System (TPMS) if tires of this type are installed.

Tires of this type have specially reinforced sidewalls that make it possible to continue driving to a limited extent even though the tire has lost some or all of its inflation pressure. These tires are mounted on special rims (normal tires can also be mounted on these rims).

If an SST tire loses inflation pressure, the yellow TPMS symbol illuminates in the instrument panel and a text message is also displayed. If this happens, reduce speed to not

more than 50 mph (80 km/h). The tire should be replaced as soon as possible.

Drive carefully; it may be difficult to determine which tire is damaged. To find the damaged tire, check the inflation pressure in all four tires.



WARNING

- SST tires should only be mounted by service technicians who are familiar with tires of this type.
- SST tires may only be mounted on vehicles equipped with TPMS.
- Do not drive faster than 50 mph (80 km/h) if TPMS indicates that a tire has lost inflation pressure.
- Do not drive farther than 50 miles (80 km) before replacing a damaged SST tire.
- Drive carefully and avoid e.g., hard braking or fast turns.
- SST tires must be replaced if they are damaged. A tire of this type cannot be repaired.

* Option/accessory, for more information, see Introduction.

Washing and cleaning the vehicle.....	208
Paint touch up.....	213



08

CAR CARE

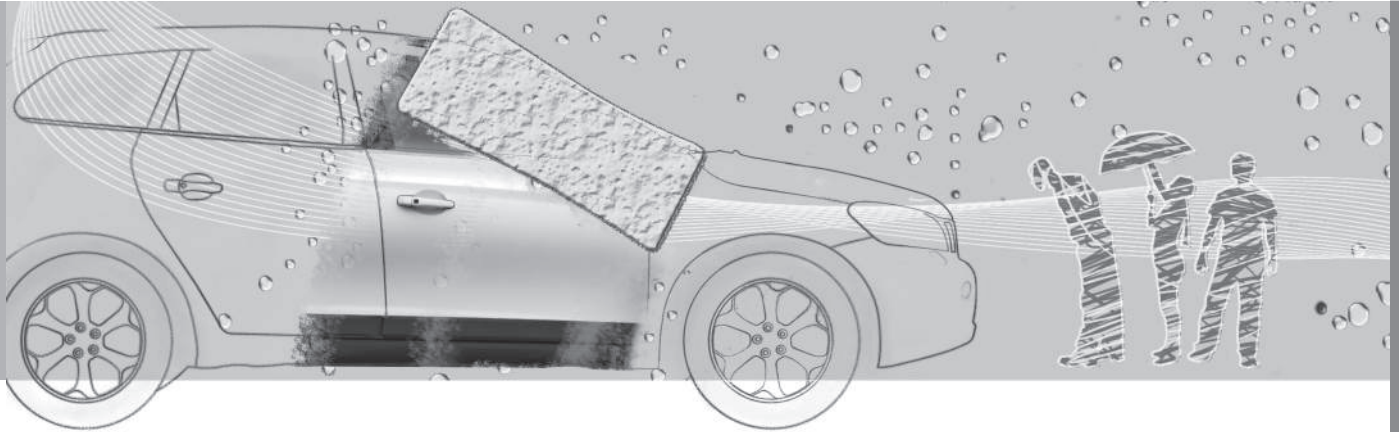



Washing and cleaning the vehicle

Washing

- The vehicle should be washed at regular intervals since dirt, dust, insects and tar spots adhere to the paint and may cause damage. It is particularly important to wash the vehicle frequently in the winter-time to prevent corrosion, when salt has been used on the roads.
- When washing the vehicle, do not expose it to direct sunlight. Use lukewarm water to soften the dirt before you wash with a sponge, and plenty of water, to avoid scratching.
- Bird droppings: Remove from paintwork as soon as possible. Otherwise the finish may be permanently damaged.
- A detergent can be used to facilitate the softening of dirt and oil.

CAUTION

Chromed wheels: Clean chrome-plated wheels using the same detergents used for the body of the vehicle. Aggressive wheel cleaning agents can permanently stain chrome-plated wheels.

- Dry the vehicle with a clean chamois and remember to clean the drain holes in the doors and rocker panels.
- Tar spots can be removed with tar remover after the vehicle has been washed.
- A stiff-bristle brush and lukewarm soapy water can be used to clean the wiper blades. Frequent cleaning of the windshield and wiper blades improves visibility considerably and also helps prolong the service life of the wiper blades.
- Wash off the dirt from the underside (wheel housings, fenders, etc.).
- In areas of high industrial fallout, more frequent washing is recommended.

Suitable detergents

Special vehicle washing detergents should be used. A suitable mixture is about 2.5 fl. oz. (8.5 cl) of detergent to 2.6 US gal. (10 liters) of warm water. After washing with a detergent the vehicle should be well rinsed with clean water.

CAUTION

- Avoid waxing or polishing plastic or rubber components
- Polishing chromed strips can wear away or damage the surface
- Polishes containing abrasive substances should not be used

CAUTION

- Dirt, snow, etc., on the headlights can reduce lighting capacity considerably. Clean the headlights regularly, for example when refueling.
- During high pressure washing, the spray mouthpiece must never be closer to the vehicle than 13 " (30 cm). Do not spray into the locks.

Special moonroof cautions:

- Always close the moonroof and sun shade before washing your vehicle.
- Never use abrasive cleaning agents on the moonroof.
- Never use wax on the rubber seals around the moonroof.



Washing and cleaning the vehicle

Exterior components

Volvo recommends the use of special cleaning products, available at your Volvo retailer, for cleaning colored plastic, rubber, or ornamental components such as chromed strips on the exterior of your vehicle. The instructions for using these products should be followed carefully. Solvents or stain removers should not be used.

CAUTION

- Avoid waxing or polishing plastic or rubber components
- Polishing chromed strips can wear away or damage the surface
- Polishes containing abrasive substances should not be used

NOTE

When washing the vehicle, remember to remove dirt from the drain holes in the doors and sills.

WARNING

- When the vehicle is driven immediately after being washed, apply the brakes several times in order to remove any moisture from the brake linings.
- Engine cleaning agents should not be used when the engine is warm. This constitutes a fire risk.

Automatic washing – simple and quick

- We do NOT recommend washing your vehicle in an automatic wash during the first few months (because the paint will not have hardened sufficiently).
- An automatic wash is a simple and quick way to clean your vehicle, but it is worth remembering that it may not be as thorough as when you yourself go over the vehicle with sponge and water. Keeping the underbody clean is most important, especially in the winter. Some automatic washers do not have facilities for washing the underbody.
- Before driving into an automatic car wash, make sure that side view mirrors, auxiliary lamps, etc, are secure, and that any antenna(s) are retracted or removed. Otherwise there is risk of the machine dislodging them.

Exterior lighting

Condensation may form temporarily on the inside of the lenses of exterior lights such as headlights, fog lights, or tail lights. This is normal and the lights are designed to withstand moisture. Normally, condensation will dissipate after the lights have been on for a short time.

Polishing and waxing

- Normally, polishing is not required during the first year after delivery, however, waxing may be beneficial.
- Before applying polish or wax the vehicle must be washed and dried. Tar spots can be removed with kerosene or tar remover. Difficult spots may require a fine rubbing compound.
- After polishing use liquid or paste wax.
- Several commercially available products contain both polish and wax.
- Waxing alone does not substitute for polishing a dull surface.
- A wide range of polymer-based car waxes can be purchased today. These waxes are easy to use and produce a long-lasting, high-gloss finish that pro-



Washing and cleaning the vehicle

protects the bodywork against oxidation, road dirt and fading.

- Do not polish or wax your vehicle in direct sunlight (the surface of the vehicle should not be warmer than 113° F (45° C)).

CAUTION

Volvo does not recommend the use of long-life or durable paint protection coatings, some of which may claim to prevent pitting, fading, oxidation, etc. These coatings have not been tested by Volvo for compatibility with your vehicle's clear coat. Some of them may cause the clear coat to soften, crack, or cloud. Damage caused by application of paint protection coatings may not be covered under your vehicle's paint warranty.

Mirrors with the water repellent glass coating

- Do not apply wax, degreasing agents, etc to this glass. This could damage the coating.
- Clean the glass surface with care to avoid scratching.

NOTE

The water repellent coating is subject to natural wear

- In order to maintain the coating's water repellent characteristics, it should be treated with a special compound that is available at your Volvo retailer.
- This treatment should be carried out for the first time after three years, and thereafter once a year.

Cleaning the upholstery

Fabric

Clean with soapy water or a detergent. For more difficult spots caused by oil, ice cream, shoe polish, grease, etc., use a clothing/fabric stain remover. Consult your Volvo retailer.

Interior plastic components

Cleaning interior plastic components should be done with a cleaning agent specially designed for this purpose. Consult your Volvo retailer.

Alcantera™ suede-like material

Suede-like upholstery can be cleaned with a soft cloth and mild soap solution.

Leather care

Volvo's leather upholstery is manufactured with a protectant to repel soiling. Over time, sunlight, grease and dirt can break down the protection. Staining, cracking, scuffing, and fading can result.

Volvo offers an easy-to-use, non-greasy leather care kit formulated to clean and beautify your vehicle's leather, and to renew the protective qualities of its finish. The cleaner removes dirt and oil buildup. The light cream protectant restores a barrier against soil and sunlight.

Volvo also offers a special leather softener that should be applied after the cleaner and protectant. It leaves leather soft and smooth, and reduces friction between leather and other finishes in the vehicle.

Volvo recommends cleaning, protecting and conditioning your vehicle's leather two to four times a year. Ask your Volvo retailer about Leather Care Kit 951 0251 and Leather Softener 943 7429.

Cleaning leather upholstery

1. Pour leather cleaner on a damp sponge and squeeze it until the cleaner foams.
2. Apply the foam to the stain by moving the sponge with circular movements.



Washing and cleaning the vehicle

3. Dampen the stain thoroughly with the sponge. Let the sponge absorb the stain, do not rub.
4. Dry the stain with soft paper towels or a towel, and allow the leather to dry completely.

Protecting leather upholstery

1. Put a small amount of protectant cream on a cloth and apply a thin coating of cream to the upholstery with light circular movements.
2. Allow the leather to dry for 20 minutes.

This will help the leather resist staining and protect against sunlight's harmful UV rays.

CAUTION

- Under no circumstances should gasoline, naphtha or similar cleaning agents be used on the plastic or the leather since these can cause damage.
- Take extra care when removing stains such as ink or lipstick since the coloring can spread.
- Use solvents sparingly. Too much solvent can damage the seat padding.
- Start from the outside of the stain and work toward the center.
- Sharp objects (e.g. pencils or pens in a pocket) or velcro fasteners on clothing may damage the textile upholstery.
- Clothing that is not colorfast, such as new jeans or suede garments, may stain the upholstery.

Cleaning a leather-covered steering wheel

- Remove soil, dust, etc., with a damp sponge and a neutral soap solution.
- Leather should be allowed to breath. Never cover the steering wheel with a plastic protector.
- Volvo recommends cleaning, protecting and conditioning the steering wheel with Volvo's Leather Care Kit 951 0251 and Leather Softener 943 7429.

If there are stains on the steering wheel:

Type 1 (ink, wine, coffee, milk, sweat or blood)

- Use a soft cloth or sponge. Wipe the wheel with a solution with 5% ammonia. For blood stains, mix approx. 1 cup (2 dl) of water and one ounce (25g) of salt and wipe the stain.

Type 2 (fat, oil, sauces, or chocolate)

1. Same procedure as for type I stains.
2. Finish by rubbing the wheel with absorbent paper or a towel.

Type 3 (dry soil or dust)

1. Remove the soil/dust with a soft brush.
2. Same procedure as for type I stains.

CAUTION

Sharp objects, such as rings, could damage the leather on the steering wheel.

Cleaning the seat belts

Clean only with lukewarm water and a mild soap solution.

Cleaning floor mats

The floor mats should be vacuumed or brushed clean regularly, especially during winter when they should be taken out for dry-



Washing and cleaning the vehicle

ing. Spots on textile mats can be removed with a mild detergent.



Paint touch up

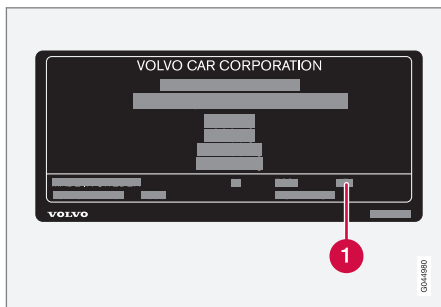

Model plate with paint color code (1).¹

Paint damage requires immediate attention to avoid rusting. Make it a habit to check the finish regularly – when washing the vehicle for instance. Touch-up if necessary.

Paint repairs require special equipment and skill. Contact a trained and qualified Volvo service technician for any extensive damage.

Minor scratches can be repaired by using Volvo touch-up paint.

Color code

Make sure you have the right color. The color code number is on the model plate in the engine compartment.

Minor stone chips and scratches

Material:

- Primer – can
- Paint – touch-up pen
- Brush
- Masking tape
- If the stone chip has not gone down to the bare metal and an undamaged color coat remains, you can add paint immediately after removing dirt.

i NOTE

When touching up the vehicle, it should be clean and dry. The surface temperature should be above 60° F (15° C).

Minor scratches on the surface

If the stone chip has not penetrated down to the metal and an undamaged layer of paint remains, the touch-up paint can be applied as soon as the spot has been cleaned.

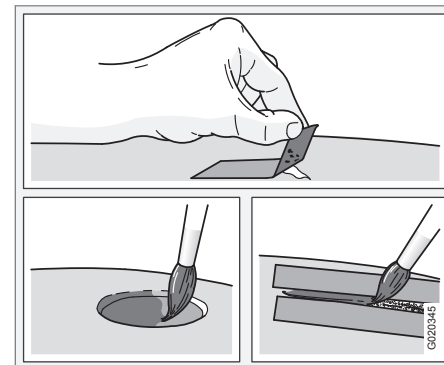

Deep scratches

- Place a strip of masking tape over the damaged surface. Pull the tape off so that any loose flakes of paint adhere to it.
- Thoroughly mix the primer and apply it with a small brush. When the primer surface is dry, the paint can be applied using a brush. Mix the paint thoroughly; apply several thin paint coats and let dry after each application.

If there is a longer scratch, you may want to protect surrounding paint by masking it off.

¹ The model plate is located on the passenger's side center door pillar.

Volvo service.....	216
Maintaining your vehicle.....	217
Working on your vehicle.....	219
Engine compartment.....	221
Engine oil.....	222
Fluids.....	224
Wiper blades.....	226
Battery.....	227
Replacing bulbs.....	230
Fuses.....	238



09

MAINTENANCE AND SERVICING

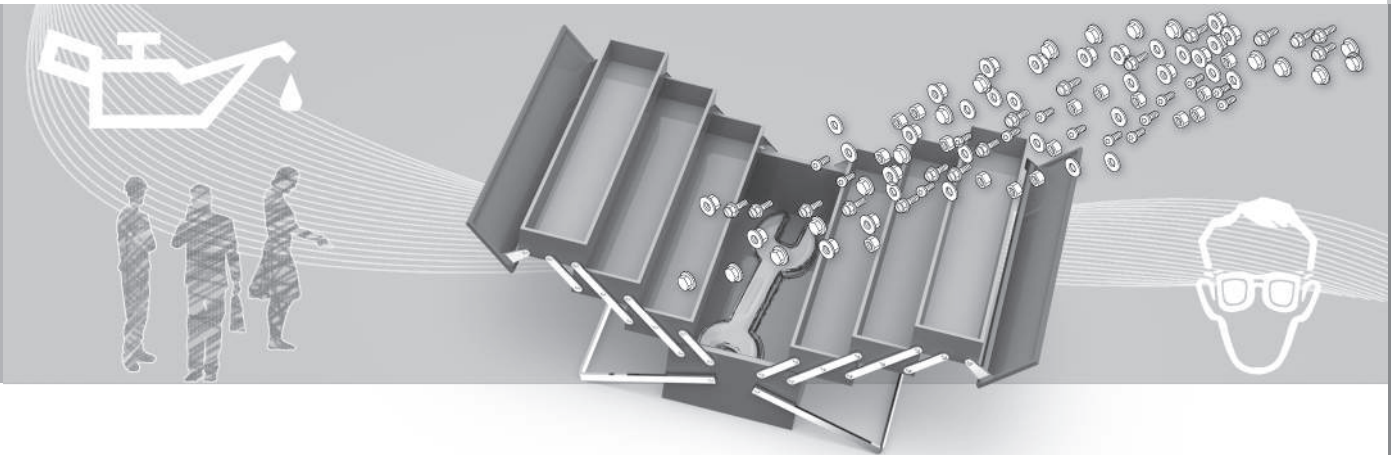



Volvo service

Maintenance service

Periodic maintenance will help keep your vehicle running well. The maintenance services contain several checks that require special instruments and tools and therefore must be performed by a qualified technician. To keep your Volvo in top condition, specify time-tested and proven Genuine Volvo Parts and Accessories.

The Federal Clean Air Act – U.S.

The Federal Clean Air Act requires vehicle manufacturers to furnish written instructions to the ultimate purchaser to assure the proper servicing and function of the components that control emissions. These services, which are listed in the "Warranty and Service Records Information booklet," are not covered by the warranty. You will be required to pay for labor and material used.

Maintenance services

Your Volvo passed several major inspections before it was delivered to you, in accordance with Volvo specifications. The maintenance services outlined in the Warranty and Service Records Information booklet, many of which will positively affect your vehicle's emissions, should be performed as indicated. It is recommended that receipts for vehicle emission

services be retained in case questions arise concerning maintenance.

Inspection and service should also be performed anytime a malfunction is observed or suspected.

Applicable warranties

In accordance with applicable U.S. and Canadian regulations, the following list of warranties is provided.

- New Car Limited Warranty
- Parts and Accessories Limited Warranty
- Corrosion Protection Limited Warranty
- Seat Belt and Supplemental Restraint Systems Limited Warranty
- Emission Design and Defect Warranty
- Emission Performance Warranty



NOTE

- Refer to your Warranty and Service Records Information booklet for a comprehensive service and maintenance schedule up to 150,000 miles (240,000 km). This program contains inspections and services necessary for the proper function of your vehicle and includes components that affect vehicle emissions.
- The Warranty and Service Records Information booklet also contains detailed information concerning the warranties that apply to your vehicle.

**Maintaining your vehicle****Owner maintenance**

Periodic maintenance requirements and intervals are described in your vehicle's Warranty and Service Records Information booklet.

The following points can be carried out between the normally scheduled maintenance services.

Each time the vehicle is refueled

- Check the engine oil level
- Clean the windshield, windshield wipers, headlights, and tail lights

Monthly

- Check cold tire pressure in all tires. Inspect the tires for wear.
- Check that engine coolant and other fluid levels are between the indicated "min" and "max" markings.
- Clean interior glass surfaces with a glass cleaner and soft paper towels.
- Wipe driver information displays with a soft cloth.
- Visually inspect battery terminals for corrosion. Corrosion may indicate a loose terminal connector, or a battery near the end of its useful service life. Consult a trained and qualified Volvo service technician for additional information.

As needed

- Wash the vehicle, including the undercarriage, to reduce wear that can be caused by a buildup of dirt, and corrosion that can be caused by salt residues.
- Clean leaves and twigs from air intake vents at the base of the windshield, and from other places where they may collect.
- Complete service information for qualified technicians is available online for purchase or subscription at www.volvotechinfo.com.

Emission inspection readiness**What is an Onboard Diagnostic System (OBD II)?**

OBD II is part of your vehicle's computerized engine management system. It stores diagnostic information about your vehicle's emission controls. It can light the Check Engine light (MIL) if it detects an emission control "fault." A "fault" is a component or system that is not performing within an expected range. A fault may be permanent or temporary. OBD II will store a message about any fault.

How do states use OBD II for emission inspections?

Many states connect a computer directly to a vehicle's OBD II system. The inspector can

then read "faults." In some states, this type of inspection has replaced the tailpipe emission test.

How can my vehicle fail OBD II emission inspection?

Your vehicle can fail OBD II emission inspection for any of the following reasons.

- If your Check Engine (MIL) light is lit, your vehicle may fail inspection.
- If your vehicle's Check Engine light was lit, but went out without any action on your part, OBD II will still have a recorded fault. Your vehicle may pass or fail, depending on the inspection practices in your area.
- If you had recent service that required disconnecting the battery, OBD II diagnostic information may be incomplete and "not ready" for inspection. A vehicle that is not ready may fail inspection.

How can I prepare for my next OBD II emission inspection?

- If your Check Engine (MIL) light is lit – or was lit but went out without service, have your vehicle diagnosed and, if necessary, serviced by a qualified Volvo technician.
- If you recently had service for a lit Check Engine light, or if you had service that required disconnecting the battery, a period of driving is necessary to bring the





Maintaining your vehicle

OBD II system to "ready" for inspection. A half-hour trip of mixed stop-and-go/highway driving is typically needed to allow OBD II to reach readiness. Your Volvo retailer can provide you with more information on planning a trip.

- Maintain your vehicle in accordance with your vehicle's maintenance schedule.



Working on your vehicle

Note the following before you begin working on your vehicle:

Battery

- Ensure that the battery cables are correctly connected and tightened.
- Never disconnect the battery when the engine is running (e.g., when replacing the battery).
- Never use a fast charger to charge the battery. The battery cables should be disconnected when recharging.
- The battery contains acid that is both corrosive and poisonous. It is important that the battery is handled in an environmentally friendly way. See page 227 for more information on handling the battery.

Hoisting the vehicle

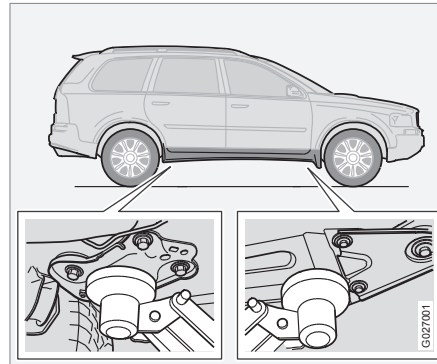

If a garage jack is used to lift the vehicle, the two jack attachments points should be used. They are specially reinforced to bear the weight of the vehicle (see the illustration). A garage jack can also be placed under the front of the engine support frame. Take care not to damage the splash guard under the engine. Ensure that the jack is positioned so that the vehicle cannot slide off it. Always use axle stands or similar structures. The vehicle's gross vehicle weight is between 5770 lbs (2630 kg) and 6080 lbs (2760 kg). Use a jack and stands rated for this weight.

If a two-post hoist is used to lift the vehicle, the front and rear lift arm pads should be centered under the reinforced lift plates on the inboard edge of the sill rail (see illustration).

WARNING

The ignition system has very high voltage! The voltage in the ignition system is dangerous!

Do not touch spark plugs, ignition cables or the ignition coil when the engine is running or the ignition is switched on!

The ignition should be switched off when:

- Conducting engine tests.
- Replacing parts in the ignition system, such as spark plugs, ignition coil, distributor, ignition cables, etc.

WARNING

Never try to repair any part of the SRS/SIPS/WHIPS/IC systems yourself. Any interference in the system could cause malfunction and serious injury. Any work should only be performed by an authorized Volvo workshop.



Working on your vehicle

Belt check

Check the belt regularly to make sure it is in good condition and is clean. A worn or dirty belt can cause poor cooling and low alternator output as well as impair the operation of the power steering and the air conditioning unit.



NOTE

The drive belt is equipped with a self-tensioning mechanism and requires no adjustment between changes.



WARNING

The engine must not be running when this check is performed.

Check coolant level

The cooling system must be filled with coolant and not leak to operate at maximum efficiency. Check the coolant level regularly. The level should be between the **MAX** and **MIN** marks on the expansion tank. The check should be made with particular thoroughness when the engine is new or when the cooling system has been drained.

Do not remove the filler cap other than for topping up with coolant. Frequent removal may prevent coolant circulation between the

engine and the expansion tank during engine warm up and cooling.

Changing coolant

Normally, the coolant does not need to be changed. If the system must be drained, consult a trained and qualified Volvo service technician.

Do not top off with water only. This reduces the rust-protective and antifreeze qualities of the coolant and has a lower boiling point. It can also cause damage to the cooling system if it should freeze. Top off with Volvo Genuine Coolant/Antifreeze only (a 50/50 mix of water and antifreeze).



CAUTION

The cooling system must always be kept filled to the correct level. If it is not kept filled, there can be high local temperatures in the engine which could result in damage. Different types of antifreeze/coolant may not be mixed.



WARNING

- Never remove the expansion tank cap while the engine is warm. Wait until the engine cools.
- If it is necessary to top off the coolant when the engine is warm, unscrew the expansion tank cap slowly so that the overpressure dissipates.



Engine compartment

09

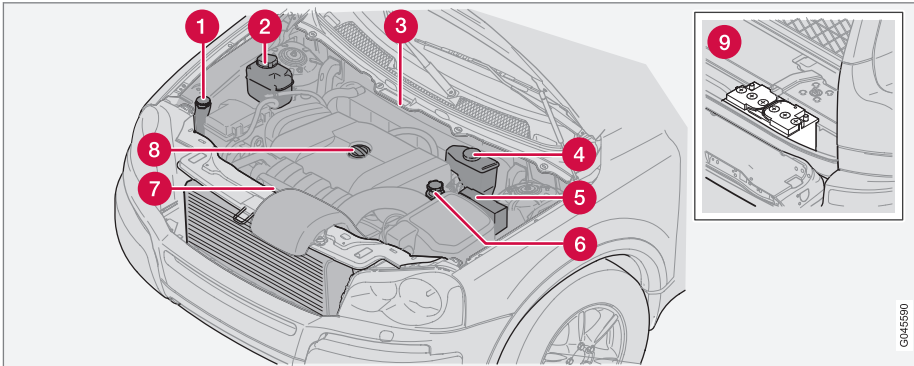

G045890

- 1 Washer fluid reservoir
- 2 Expansion tank-coolant
- 3 Data plate
- 4 Brake fluid reservoir
- 5 Relay/fuse box
- 6 Power steering fluid reservoir
- 7 Dipstick-engine oil
- 8 Filler cap-engine oil
- 9 Battery (under floor in rear cargo area)

WARNING

The cooling fan (located at the front of the engine compartment, behind the radiator) may start or continue to operate (for up to 6 minutes) after the engine has been switched off.



Engine oil

Oil specifications

Full synthetic engine oil meeting the minimum ACEA A5/B5 must be used. Lower quality oils may not offer the same fuel economy, engine performance, or engine protection.

Refer to the Warranty and Service Records information booklet for information on oil change intervals and oil type requirements.

i NOTE

This vehicle comes from the factory with synthetic oil.

Oil additives must not be used.

Oil viscosity

Incorrect viscosity oil can shorten engine life under normal use. SAE 5W-30 will provide good fuel economy and engine protection. See the viscosity chart.

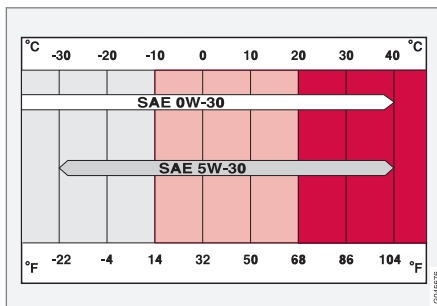

Viscosity chart

Extreme engine operation

SAE 0W-30 oil meeting ACEA A5/B5 requirements is recommended for driving in areas with sustained low temperatures.

i NOTE

Volvo uses different systems to indicate a low oil level or pressure. Some models have an oil pressure sensor, in which case a warning symbol (see page 60) is used to indicate low oil pressure. Other models have an oil level sensor, in which case the driver is alerted by the warning symbol in the center of the instrument panel and a text in the information display. Some models use both systems. Contact a trained and qualified Volvo service technician for more information.

Changing engine oil and oil filter

See page 290 for oil volumes. Refer to the Warranty and Service Records Information booklet for information on the oil change intervals.

i NOTE

Volvo does not recommend the use of oil additives.

Checking and adding oil

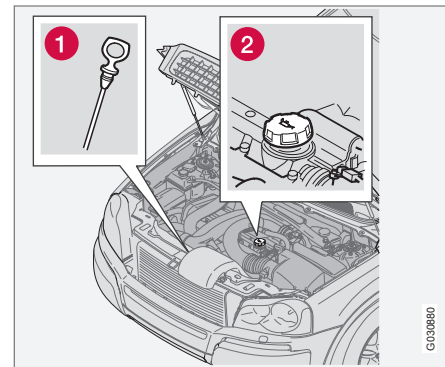

Location of dipstick (1) and oil filler cap (2)

The oil level should be checked at regular intervals, particularly during the period up to the first scheduled maintenance service.



Engine oil

- The vehicle should be parked on a level surface when the oil is checked.
- **If the engine is warm**, wait for at least 10-15 minutes after the engine has been switched off before checking the oil.

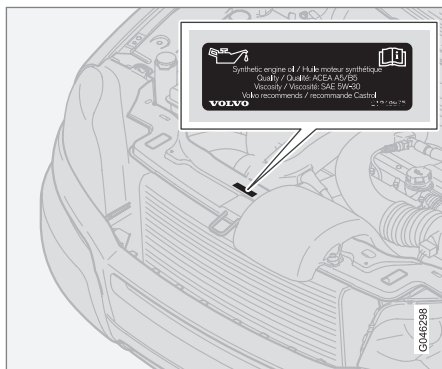

Volvo recommends Castrol oil products

Checking the oil

- Pull out the dipstick and wipe it with a lint-free rag.
- Reinsert the dipstick, pull it out, and check the oil level.
- Add oil if necessary. If the level is close to the **MIN** mark, add approximately 0.5 US quarts (0.5 liters) of oil.

- Recheck the level and add more oil if necessary until the level is near the **MAX** mark.
- Oil level should be between the **MIN** and **MAX** marks on the dipstick.

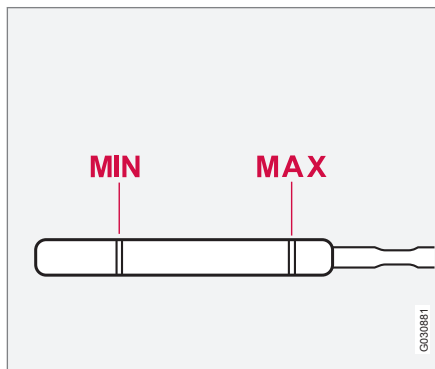

CAUTION

- Check the engine oil level regularly.
- Never fill oil above the **MAX** mark or let the oil level go below the **MIN** mark. This could result in serious damage to the engine.
- Always add oil of the same type and viscosity as already used.
- Oil changes should be carried out by a trained and qualified Volvo service technician.

WARNING

Do not allow oil to spill onto or come into contact with hot exhaust pipe surfaces.



Fluids

Washer fluid reservoir

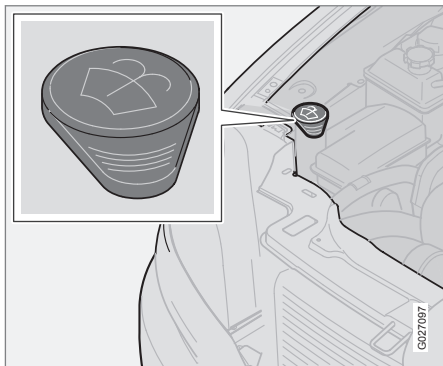

Washer fluid reservoir

The washer fluid reservoir is located in the engine compartment and holds approx. 6.8 US qts (6.5 liters).

When there is less than approximately 1 US qt (1 liter) remaining in the reservoir, the washer fluid spray will be directed to the windshield only.

During cold weather, the reservoir should be filled with windshield washer solvent containing antifreeze.

Changing coolant

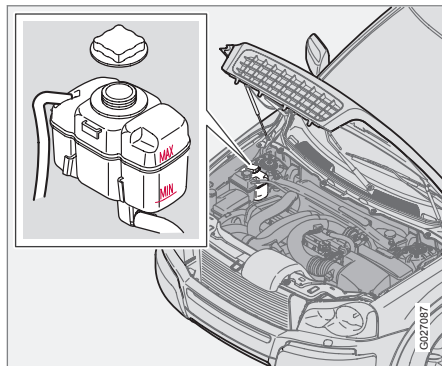

Coolant reservoir

Normally, the coolant does not need to be changed. If the system must be drained, consult a trained and qualified Volvo service technician.

CAUTION

- If necessary, top up the cooling system with Volvo Genuine Coolant/Antifreeze only (a 50/50 mix of water and antifreeze).
- Different types of antifreeze/coolant may not be mixed.
- If the cooling system is drained, it should be flushed with clean water or premixed anti-freeze before it is refilled with the correct mixture of water/antifreeze.
- The cooling system must always be kept filled to the correct level, and the level must be between the **MIN** and **MAX** marks. If it is not kept filled, there can be high local temperatures in the engine which could result in damage. Check coolant regularly!
- Do not top up with water only. This reduces the rust-protective and anti-freeze qualities of the coolant and has a lower boiling point. It can also cause damage to the cooling system if it should freeze.
- Do not use chlorinated tap water in the vehicle's cooling system.



! WARNING

- Never remove the coolant reservoir cap while the engine is warm. Wait until the engine cools.
- If it is necessary to top up the coolant when the engine is warm, unscrew the coolant reservoir cap slowly so that the overpressure dissipates.

Brake fluid reservoir

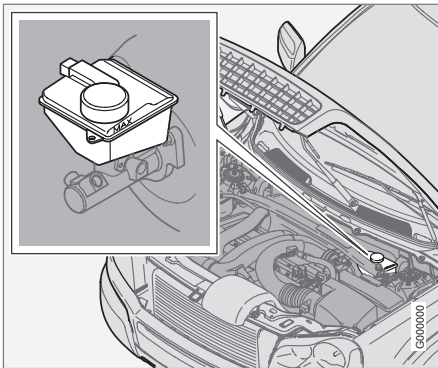

The brake fluid should always be above the **MIN** mark on the side of the reservoir. Check, without removing the cap, that there is sufficient fluid in the reservoir.

Fluid type: DOT 4 boiling point >536 °F (>280 °C).

Replace: Every second year or 30,000 miles (48,000 km). The fluid should be replaced once a year or every 15,000 miles (24,000 km) when driving under extremely hard conditions (mountain driving, etc.).

Always entrust brake fluid changing to a trained and qualified Volvo service technician.

! WARNING

- If the fluid level is below the **MIN** mark in the reservoir or if a brake-related message is shown in the information display: **DO NOT DRIVE**. Have the car towed to a trained and qualified Volvo service technician and have the brake system inspected.
- Dot 4 should never be mixed with any other type of brake fluid.

Power steering fluid reservoir

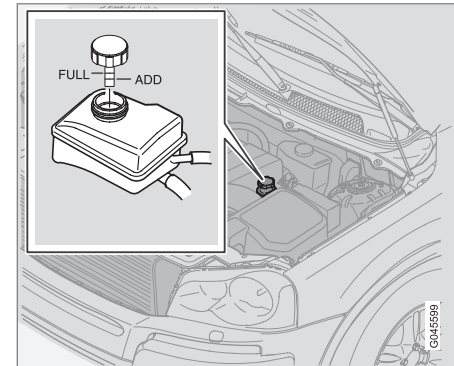

The fluid level should always be between the **ADD** and **FULL** marks.

Fluid type: Volvo synthetic power steering fluid (Pentosin CHF 11S) P/N 1161529 or equivalent.

Replace: No fluid change required.

If a problem should occur in the power steering system or if the vehicle has no electrical current and must be towed, it is still possible to steer the vehicle. However, keep in mind that greater effort will be required to turn the steering wheel.



Wiper blades

Windshield wiper blades

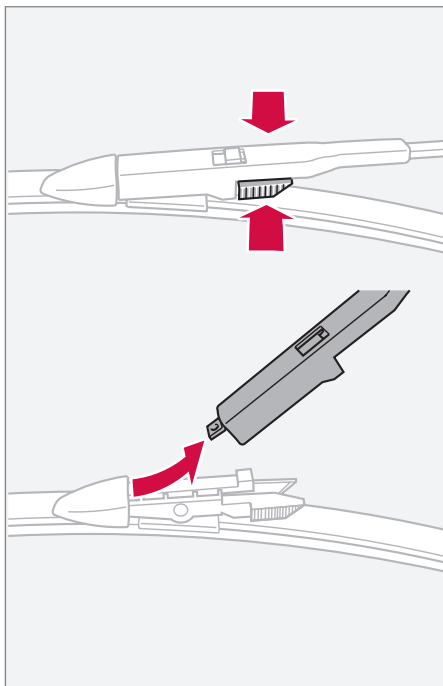

To change a windshield wiper blade:

1. Fold the wiper arm out from the windshield and hold the wiper blade.
2. Press in the grooved catches and pull out the wiper blade.
3. Insert a new wiper blade and ensure that it is securely in place.

NOTE

The driver's side wiper blade is longer than the one on the passenger's side.

Tailgate wiper blade

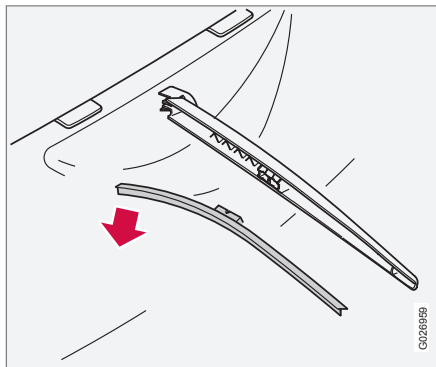

To change a tailgate wiper blade:

1. Pull the wiper arm rearward, away from the tailgate window.
2. Pull out the wiper blade as shown in the illustration.
3. Press the new wiper blade into place. Check that it is properly secured.

NOTE

Keeping the windshield/tailgate window and wiper blades clean helps improve visibility and prolongs the service life of the wiper blades, see page 208 for washing instructions.



Battery maintenance

The battery in your vehicle is located under the floor of the cargo compartment.

Driving habits and conditions, climate, the number of starts, etc. all affect the service life and function of the battery. In order for your battery to perform satisfactorily, keep the following in mind:

- Use a screw driver to open the caps or cover and a flashlight to inspect the level.
- If necessary, add distilled water. The level should never be above the indicator.
- The fluid level should be checked if the battery has been recharged.
- After inspection, be sure the cap over each battery cell or the cover is securely in place.
- Check that the battery cables are correctly connected and properly tightened.
- Never disconnect the battery when the engine is running, or when the key is in the ignition. This could damage the vehicle's electrical system.
- The battery should be disconnected from the vehicle when a battery charger is used directly on the battery.
- To help keep the battery in good condition, the vehicle should be driven for at least 15 minutes a week or connected to

a charger with an automatic charging function.

- If the battery is fully discharged a number of times, this may shorten its service life. Keeping the battery fully charged helps prolong its service life.
- The service life of a battery is affected by factors such as driving conditions and climate. Extreme cold may also further decrease the battery's starting capacity.
- Because the battery's starting capacity decreases with time, it may be necessary to recharge it if the vehicle is not driven for an extended period of time or if the vehicle is usually only driven short distances.
-



WARNING

PROPOSITION 65 WARNING!

Battery posts, terminals, and related accessories contain lead and lead compounds, chemicals known to the state of California to cause cancer and reproductive harm. Wash hands after handling.



WARNING

- Never expose the battery to open flame or electric spark.
- Do not smoke near the battery.
- Battery fluid contains sulfuric acid. Do not allow battery fluid to contact eyes, skin, fabrics or painted surfaces. If contact occurs, flush the affected area immediately with water. Obtain medical help immediately if eyes are affected.







NOTE

Used batteries should be properly disposed of at a recycling station or similar facility, or taken to your Volvo retailer.



Battery

Symbols

	Wear protection goggles
	See owner's manual for details
	Keep away from children
	Corrosive

	No smoking, no open flames, no sparks
	Explosion
 G044513	Recycle properly

Replacing the battery

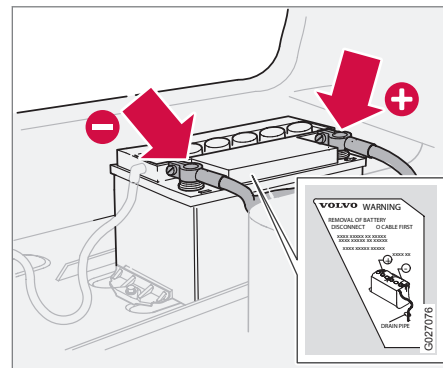

1. Switch off the ignition.
2. **Wait at least 5 minutes after switching off the ignition before disconnecting the battery** so that all information in the vehicle's electrical system can be stored in the control modules.
3. Remove the retaining bracket and unscrew the cover over the battery. Wait at least 5 minutes after switching off the ignition before disconnecting the battery so that all information in the vehicle's electrical system can be stored in the control modules.



Battery

4. Disconnect the negative (ground) cable first.

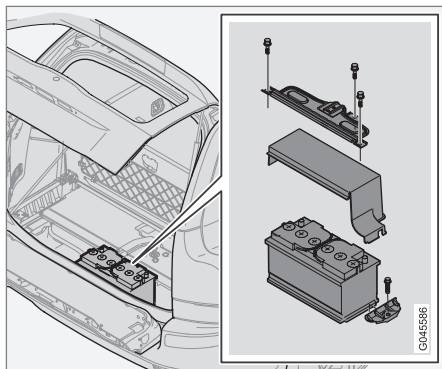

5. Disconnect the positive cable and pull the ventilation hose from the battery.
6. Lift out the old battery and put a new battery into place.
7. Connect the positive cable first.
8. Connect the negative (ground) cable.
9. Be sure that the ventilation hose is securely connected to the battery and that the other end of the hose is properly routed through the ventilation opening in the floor of the battery compartment.

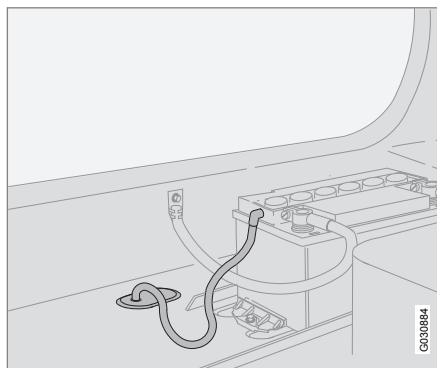

Ventilation hose

10. Reinstall the cover and retaining bracket and screw it securely in place.

i NOTE

After the battery has been disconnected or replaced, lock and unlock the vehicle with the central locking system's remote key to reactivate such features as the power windows, moonroof, courtesy lighting, etc.

! WARNING

- The battery generates hydrogen gas, which is flammable and explosive. The battery is fitted with a ventilation hose which vents hydrogen gas out of the battery compartment through a ventilation opening in the bottom of this compartment. If the battery must be replaced, it is essential that the ventilation hose is properly connected to the battery and that it is routed through the ventilation opening provided (see illustration).
- Be sure the ventilation hose is free of debris.
- Only use replacement batteries equipped with a ventilation hose. Consult a trained and qualified Volvo service technician.



Replacing bulbs

When replacing bulbs, keep the following points in mind:

- Never touch the glass of bulbs with your fingers. Grease and oils from your fingers vaporize in the heat and will leave a deposit on the reflector, which will damage it.
- The optional Active Bending Light bulbs contain trace amounts of mercury. These bulbs should always be disposed of by an authorized Volvo retailer.

The following bulbs should only be replaced by a trained and qualified Volvo service technician:

- Active Bending Lights (ABL)
- Daytime running lights (DRL) under the front bumper
- Turn signals and courtesy lights in the side door mirrors
- Reading lights and glove compartment light
- Courtesy (dome) lighting
- Rear parking lights
- Brake lights
- High-mounted brake lights

If a problem occurs with the daytime running lights (DRL) under the front bumper, the entire lamp housing will have to be replaced.

If a problem occurs with the rear parking lights or the brake lights, the entire taillight housing will have to be replaced.

See page 236 for a list of bulb specifications.

Replacing high/low beams/turn signal/parking light bulbs

WARNING

- The engine should not be running when changing bulbs.
- If the engine has been running just prior to replacing bulbs in the headlight housing, please keep in mind that components in the engine compartment will be hot.

WARNING

Active Bending Lights* - due to the high voltage used by these headlights, these bulbs should only be replaced by a trained and qualified Volvo service technician.

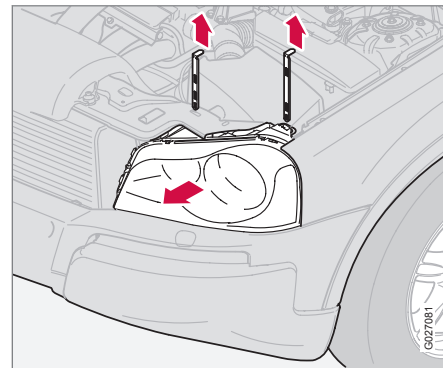

The entire lamp housing must be lifted out when replacing these bulbs.

To lift out the lamp housing:

1. Switch off the ignition.
2. Open the hood.
3. Pull up the retaining pins (see the illustration).
4. Lift out the lamp housing.



Replacing bulbs

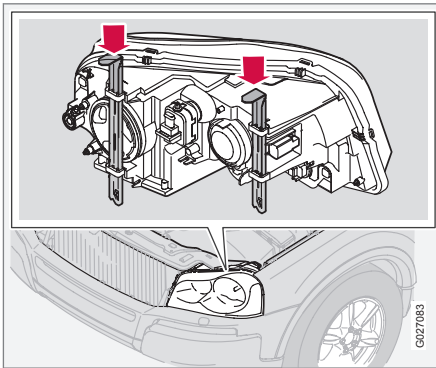

Location of the bulbs in the headlight housing

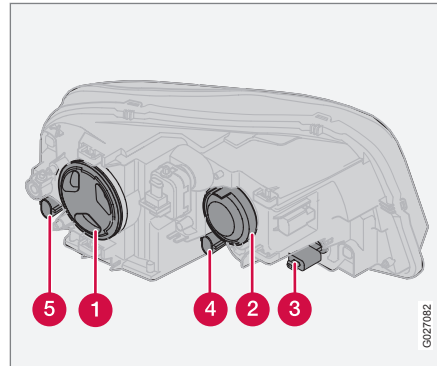

- 1 Low/high beam (models with Active Bending Lights)*, Low beam (models with Halogen headlights)
- 2 High beam¹ (models with Halogen headlights)
- 3 Turn signal
- 4 Parking light
- 5 Side marker light

¹ This bulb has no function on models with the optional Active Bending Lights.

Replacing the low beam bulb (halogen headlights)

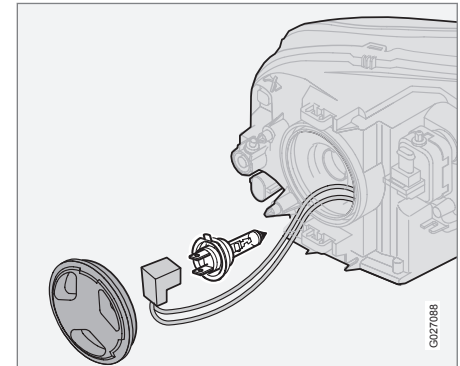

1. Remove the plastic cover over the bulb by turning it counterclockwise.
2. Pull the connector from the lamp housing.
3. Loosen the bulb's retaining spring by first moving it to the right and then moving it out of the way.
4. Pull out the bulb from the holder.
5. Insert the new bulb (without touching the glass) in the holder.



Replacing bulbs

6. Move the retaining spring up and push it slightly to the left until it seats properly.
7. Press the bulb holder into place on the headlight housing.
8. Reinstall the plastic cap. The letters "HAUT" on the cap must be upward.

Replacing the high beam bulb (halogen headlights)

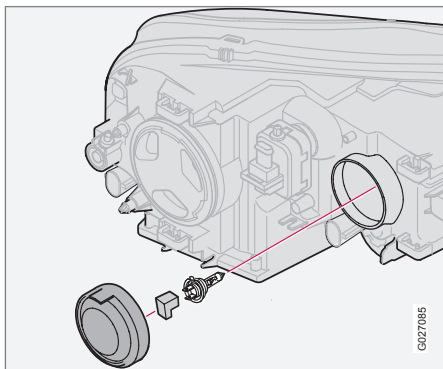

1. Remove the rubber cover by pulling it off.
2. Pull the connector from the lamp housing.
3. Loosen the bulb's retaining spring by first moving it to the right and then moving it out of the way.

4. Pull out the bulb from the holder.
5. Insert the new bulb (without touching the glass) in the holder.
6. Move the retaining spring up and push it slightly to the left until it seats properly.
7. Press the bulb holder into place on the headlight housing.
8. Press the rubber cover into place.

Replacing parking light/side marker light bulbs

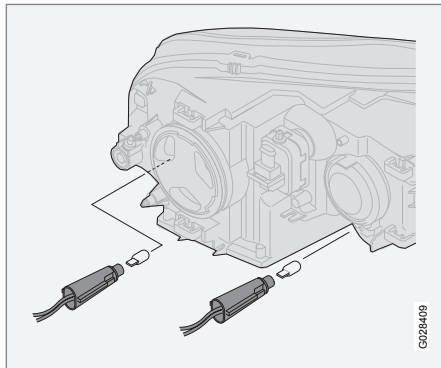

1. Turn the lamp holder approximately 1/4 turn counterclockwise and pull it out of the headlight housing.

2. Pull the bulb straight out.
3. Align the guide lugs on the side of the base of the new bulb in the grooves in the holder and press it into place.
4. Press the lamp holder into the place in the headlight housing and turn it approximately 1/4 turn clockwise.

Replacing the turn signal bulb

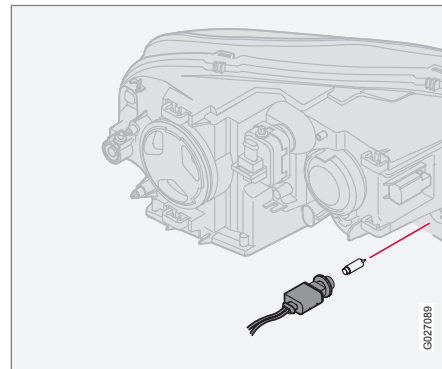

1. Turn the lamp holder approximately 1/4 turn counterclockwise and pull it out of the headlight housing.
2. Press in the bulb slightly and pull it out of the holder.



Replacing bulbs

- Align the guide lugs on the side of the base of the new bulb in the grooves in the holder. Press it in and turn it slightly clockwise.
- Press the lamp holder into the place in the headlight housing and turn it approximately 1/4 turn clockwise.

i NOTE

If the message indicating a burned out bulb remains in the information display after a bulb has been replaced, consult a trained and qualified Volvo service technician.

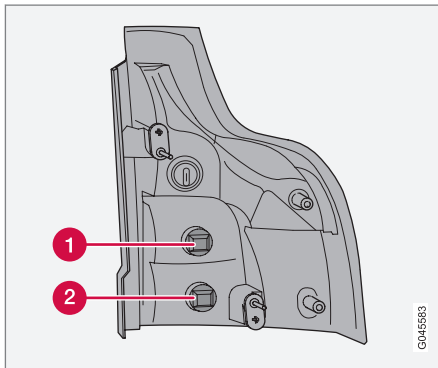
Location of taillight bulbs

- Turn signal
- Backup light



Replacing bulbs

Replacing bulbs in the taillight cluster

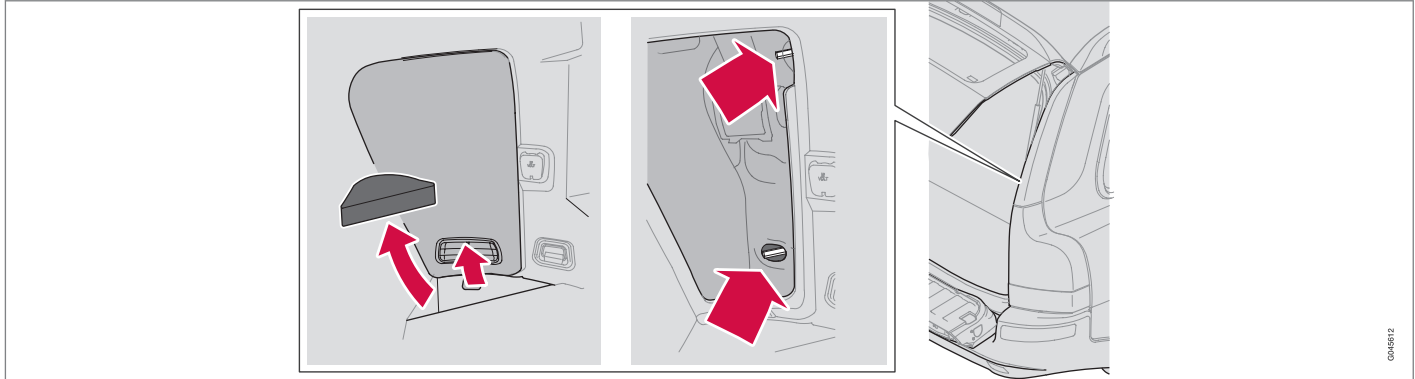

09A6512

1. Switch off all lights and turn ignition key to position **0**.
2. Fold down the lower section of the tailgate, and fold up the rear section of the cargo area floor. If the vehicle is equipped with the optional grocery bag holder, detach the holder's bands.
3. Remove the corner panel.
4. Open the cover in the side panel by pulling the tab upward and toward you.
5. Loosen the bolts.
6. Pull the entire tail light housing straight out.
7. Disconnect the wiring.
8. Place the tail light housing on a soft cloth to help avoid scratching the lens.
9. Turn the lamp holder counterclockwise and pull out.
10. Turn the bulb to be replaced counterclockwise and remove it.
11. Insert a new bulb.
12. Place the lamp holder in the groove and turn clockwise.
13. Press wiring back into place.
14. Align the tail light housing with the holes for the retaining bolts and press it into place.
15. Tighten the retaining bolts.
16. Reinsert the side and corner panels.



Replacing bulbs

Rear fog light

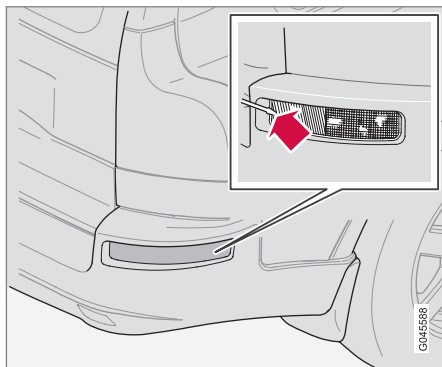

1. Switch off the ignition.
2. Carefully insert a small screwdriver (see illustration above).
3. Pry out the lamp housing.
4. Turn the bulb holder counterclockwise and remove it.
5. Turn the bulb counterclockwise and remove it.
6. Insert a new bulb and press the lamp housing back into place.

License plate lights

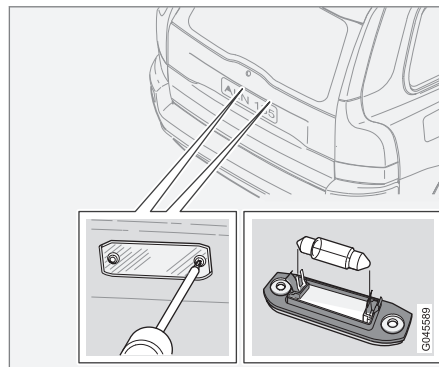

1. Turn off the lights and switch off the ignition.
2. Loosen the retaining screws with a screwdriver.
3. Loosen the bulb housing and pull it out carefully.
4. Pull out the defective bulb and insert a new one.
5. Reinsert the bulb housing and screw it into place.

Front footwell lighting

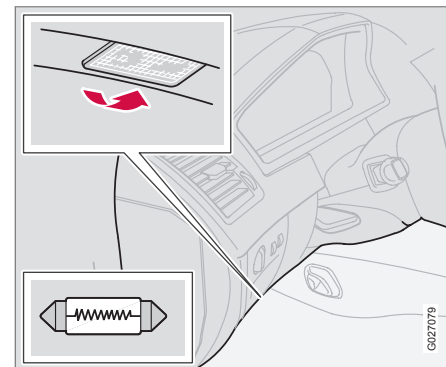

The front footwell lights are located under the dashboard on the driver's and passenger's sides.

To replace a bulb:

1. Carefully insert a screwdriver and pry out the lens.
2. Replace the defective bulb.
3. Reinstall the lens.



Replacing bulbs

Cargo compartment light

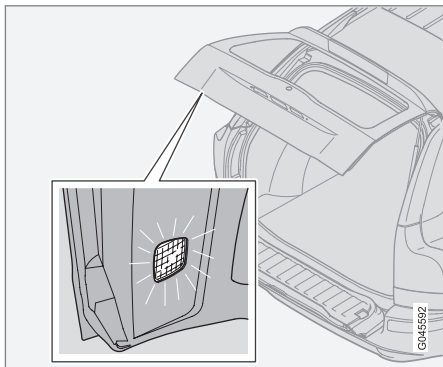

1. Carefully insert a screwdriver and pry out the lens.

2. Pry out the bulb and replace it.
3. Press the lens back into place.

Vanity mirror lights

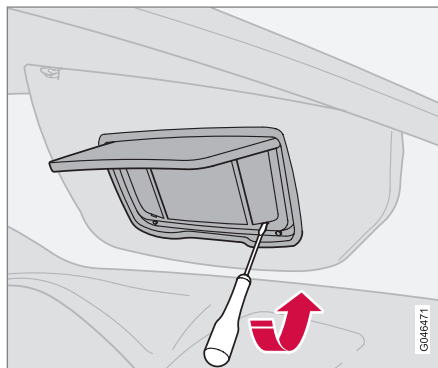

Removing the lens

1. Insert a flat screwdriver under the lens and carefully exert upward pressure to release the retaining lugs.
2. Snap out the lens.
3. Use needle nose pliers to pull the bulb straight to the side. Replace the bulb. Do not exert too much pressure on the bulb with the pliers to help avoid damaging it.

Reinserting the lens

1. Put the lens back into position.
2. Press it into place.

Bulb specifications

Lighting function	Wattage	Bulb
Low beam (halogen)	55	H11 LL
High beam (halogen)	55	H7 LL
Front turn signals	21	H21W LL



Replacing bulbs

Lighting function	Wattage	Bulb
Front parking lights, front side marker lights, rear courtesy lighting	5	W5W LL
Turn signals in door mirrors	5	WY5W LL
Rear fog light	21	H21W LL
Backup lights	21	P21W LL
Rear turn signals	21	PY21W SV
Vanity mirror lighting	2	W2x4.6d type T5
License plate lighting	5	C5W LL
Glove compartment	5	SV8.5 (length 43 mm)
Cargo area lighting	10	SV8.5 (length 43 mm)
Front footwell lighting	5	SV8.5 (length 38 mm)

i NOTE

Please consult a Volvo retailer's Parts department for the most up-to-date specifications.



Fuses

Replacing fuses

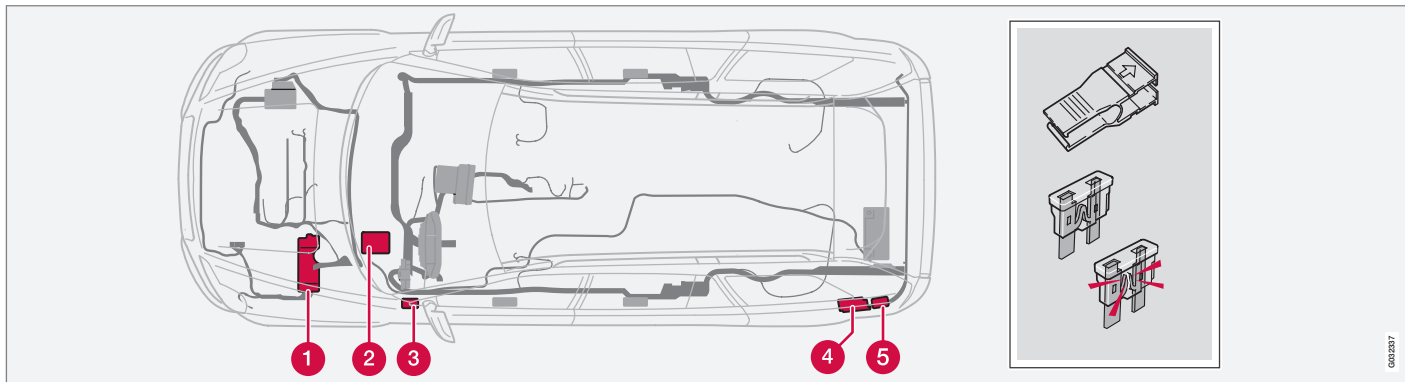

- 1 Relays/fuse box in the engine compartment
- 2 Fuse box in the passenger compartment, behind the plastic cover
- 3 Fuse box in the passenger compartment, on the edge of the dashboard
- 4 Fuse box in the cargo compartment
- 5 Fuse box in the cargo compartment¹.
- 5 Additional fuses in cargo compartment (XC90 Executive*)

If an electrical component fails to function, it is possible that a fuse has blown.

The fuse boxes are located in four different places, see the illustration above.

A label on the inside of each cover indicates the amperage and the electrical components that are connected to each fuse.

The easiest way to see if a fuse is blown is to remove it. Pull the fuse straight out. If a fuse is difficult to remove, you will find a special fuse removal tool (and several extra fuses) in

the passenger compartment fuse box on the driver's end of dashboard. From the side, examine the curved metal wire (see the illustration) to see if it is broken. If so, put in a new fuse of the **same color and amperage** (written on the fuse). Spare fuses are stored in the fuse box in the engine compartment and the passenger compartment. If fuses burn out repeatedly, have the electrical system inspected by a trained and qualified Volvo service technician.

¹ Certain markets only.

* Option/accessory, for more information, see Introduction.

** WARNING**

Never use metal objects or fuses with higher amperage than those stated on the following pages. Doing so could seriously damage or overload the vehicle's electrical system.



Fuses

Fuses in the engine compartment

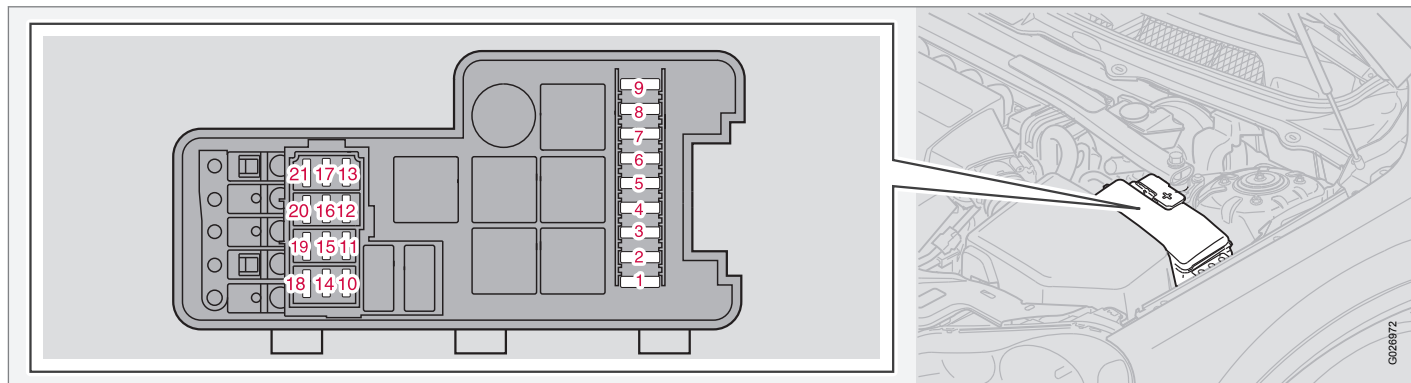

When replacing fuses, be sure to replace a blown fuse with a new one of the same color and amperage (written on the fuse).

No		A
1	ABS	30
2	ABS	30
3	Headlight washers	35
4	–	20
5	Auxiliary lights*	35

No		A
6	Starter motor relay	35
7	Windshield wipers	25
8	Fuel pump	15
9	Transmission control module	15
10	Ignition coils, engine control module	20
11	Throttle pedal sensor, A/C compressor	10

No		A
12	Engine control module, fuel injectors, mass airflow sensor	15
13	Intake manifold actuator (6-cyl.)	10
14	Heated oxygen sensor	20
15	Crankcase ventilation, solenoid valves, A/C connection, leakage diagnostics, engine control module	15
16	Driver's side low beam headlight	20



Fuses

09

No		A
17	Passenger's side low beam headlight	20
18	–	
19	Engine control module feed, engine relay	5
20	Parking lights	15
21	Vacuum pump	20



Fuses

Fuses in the passenger compartment on the edge of the dashboard

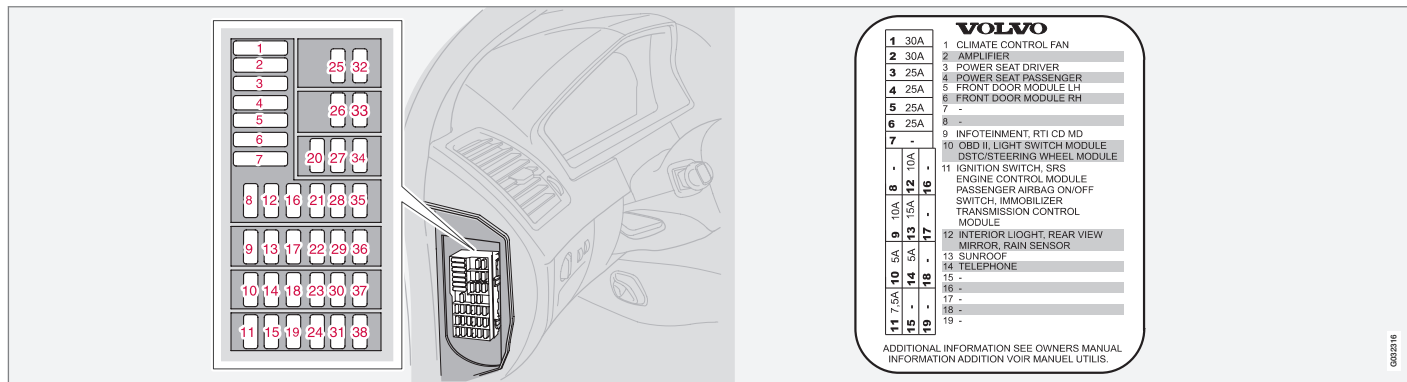

The decal shows the positions and amperage of the fuses

Fuses are located inside the access panel on the edge of the dashboard, on the driver's side. There are also a number of spare fuses. When replacing a blown fuse, be sure to replace it with a new one of the same color and amperage (written on the fuse).

No		A
1	Blower – climate system	30
2	Audio amplifier*	30
3	Power driver's seat*	25

No		A
4	Power passenger's seat*	25
5	Driver's door control module	25
6	Front passenger's door control module	25
7	–	
8	Radio, CD player, Rear Seat Entertainment (RSE)* ^A	15

No		A
9	Volvo Navigation System*, SiriusXM™ satellite radio*	10
10	On-board diagnostics, headlight switch, steering wheel angle sensor, steering wheel module	5
11	Ignition switch, SRS, engine control module, immobilizer, transmission control module	7.5

002216



No		A
12	Ceiling lighting, upper electronic control module	10
13	Moonroof*	15
14	Bluetooth hands-free system	5
-	15 – 38	-

^A See also fuse 28 in the following section "Fuse box in the passenger compartment, behind the plastic cover, driver's side"





Fuses

Fuse box in the passenger compartment, behind the plastic cover, driver's side

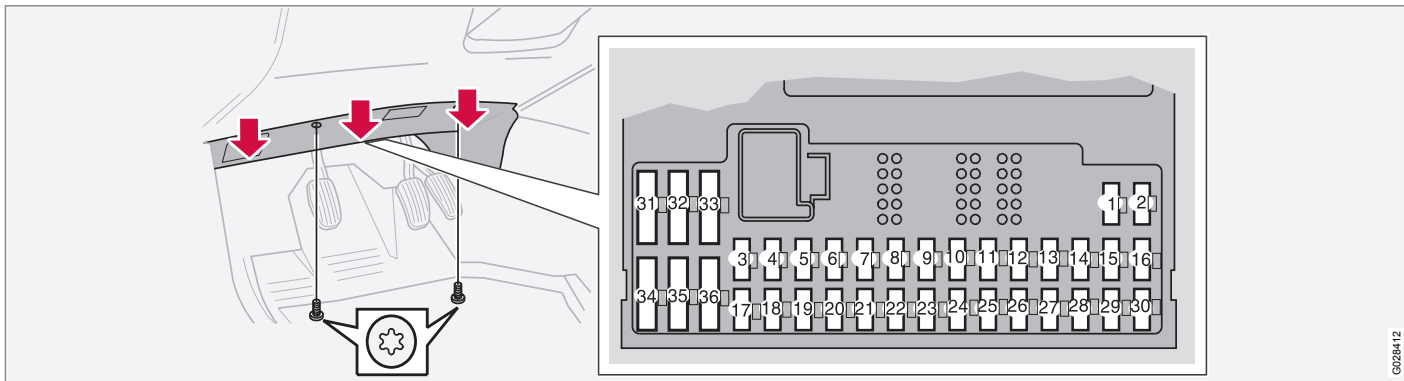

This fuse box is located behind the plastic cover below the steering wheel. When replacing a blown fuse, be sure to replace it with a new one of the same color and amperage (written on the fuse).

No		A
1	Heated passenger's seat*	15
2	Heated driver's seat*	15
3	Horn	15
4	-	

No		A
5	Audio system	10
6	-	
7	-	
8	Alarm siren*	5
9	Brake light switch feed	5
10	Instrument panel, climate system, power driver's seat, Occupant Weight Sensor	10

No		A
11	12-volt sockets – front and rear seats, refrigerator* (XC90 Executive)	15
12	-	
13	-	
14	-	
15	ABS, DSTC	5
16	Power steering, Active Bending Lights*	10

0328412



No		A
17	Driver's side daytime running light (DRL)	7.5
18	Passenger's side daytime running light (DRL)	7.5
19	–	
20	–	
21	Transmission control module	10
22	Driver's side high beam	10
23	Passenger's side high beam	10
24	–	
25	–	
26	–	
27	–	
28	Power passenger's seat*, Rear Seat Entertainment system* ^A	5
29	Fuel pump	7.5
30	Blind Spot Information System*	5
31	–	
32	–	

No		A
33	Vacuum pump	20
34	Pump – windshield and tailgate washers	15
35	–	
36	–	

^A See also fuse 8 in the previous section "Fuses in the passenger compartment on the edge of the dashboard"





Fuses

Fuses in the cargo compartment

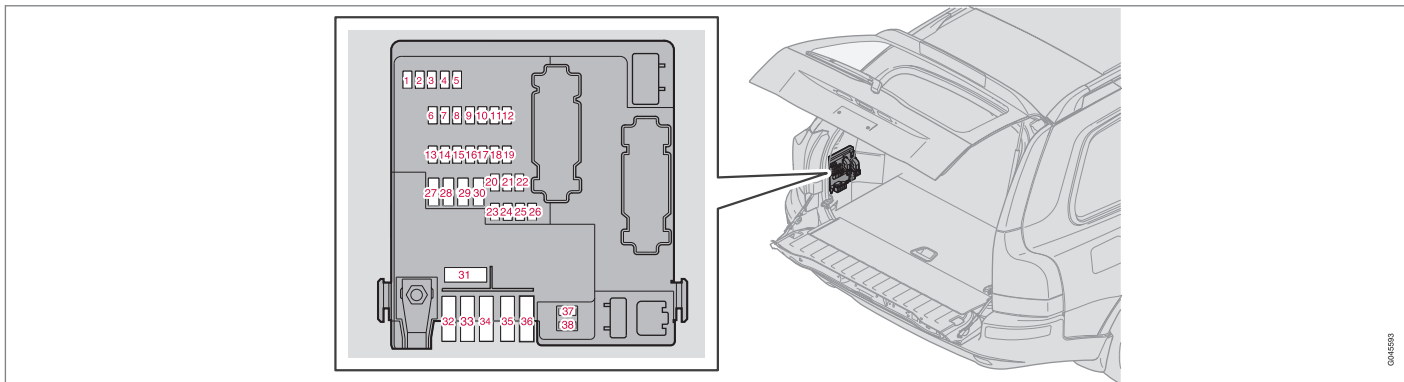

The fuses in the cargo area are located behind the panel on the driver's side of the cargo compartment. When replacing a blown fuse, be sure to replace it with a new one of the same color and amperage (written on the fuse).

No		A
1	Backup lights	10
2	Parking lights, rear foglight, cargo compartment lighting, license plate lights, brake light diodes	20

No		A
3	Accessories	15
4	-	
5	Rear Electronic module	10
6	-	
7	Trailer wiring (30 feed)*	15
8	12-volt socket in cargo compartment	15

No		A
9	Rear passenger's side door – power window, power window cutout function	20
10	Rear driver's side door – power window, power window cutout function	20
11	-	
12	-	
13	-	

0944583



Fuses

No		A
14	Rear air conditioning system*	15
15	–	
16	–	
17	Accessory audio	5
18	–	
19	Tailgate window wiper	15
20	Trailer wiring (15-feed)*	20
21	–	
22	–	
23	All Wheel Drive (AWD)	7.5
24	–	
25	–	
26	Park assist*	5
27	Main fuse: trailer wiring, park assist, All Wheel Drive	30
28	Central locking system	15
29	Driver's side trailer lighting: parking lights, turn signal*	25

No		A
30	Passenger's side trailer lighting: brake light, rear fog light, turn signal*	25
31	Main fuse: fuses 37 and 38	40
32	–	
33	–	
34	–	
35	–	
36	–	
37	Heated rear window	20
38	Heated rear window	20

* Option/accessory, for more information, see Introduction.





Fuses

Additional fuses in the cargo compartment (XC90 Executive*)

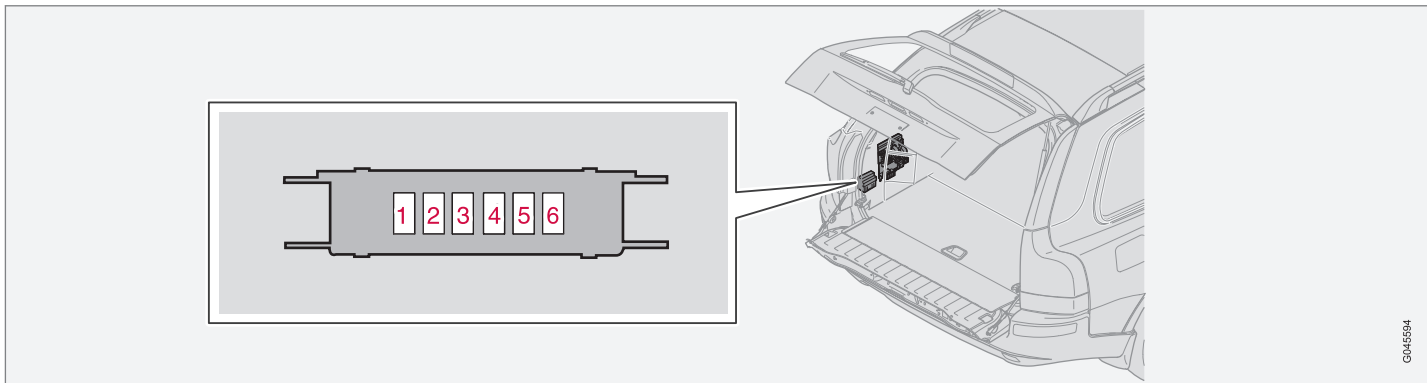

G04E594

The fuses in the cargo area are located behind the panel on the driver's side of the cargo compartment. When replacing a blown fuse, be sure to replace it with a new one of the same color and amperage (written on the fuse).

1.	Relays for rear seat heating and front seat massage	5 A
2.	Rear seat heating, driver's side	15 A
3.	Rear seat heating, passenger's side	15 A

4.	Front seat ventilation/massage	10 A
5.	-	-
6.	-	-

i NOTE
Please consult a Volvo retailer's Parts department for the most up-to-date specifications.



Audio system overview.....	252
Audio system controls.....	253
Radio functions.....	258
SiriusXM™ satellite radio.....	263
Auxiliary equipment.....	267
CD player/changer.....	270
Menu structure.....	273
Bluetooth® hands-free connection.....	274



10

AUDIO





Audio system overview

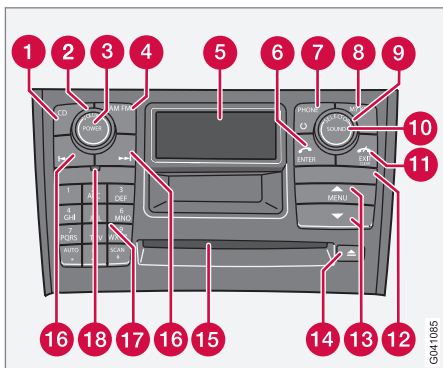

- 1 CD player**
- 2 VOLUME** – turn to adjust
- 3 POWER** – On/Off
- 4 AM/FM** – for switching between **FM1**, **FM2** and **AM**
- 5 Display**
- 6 ENTER** – select in the menu or activate a selection
- 7 PHONE**: press to turn standby on/off.
- 8 MY KEY** – programmable key for your favorite function from the menu
- 9 SELECTOR** – select sound source
- 10 SOUND** – make sound settings
- 11 EXIT/CLEAR** – step back in the menu or cancel a selection
- 12** Not in use
- 13 MENU** – menu selections/navigation
- 14** CD eject
- 15** CD slot, CD changer*
- 16** search for and store the strongest radio stations in the area in which you are driving
- 17** Station preset buttons/select a disc in the CD changer* (**1-6**)
- 18 IR*** Infrared port – for the optional navigation system remote control

* Option/accessory, for more information, see Introduction.



Audio system controls

Steering wheel keypad

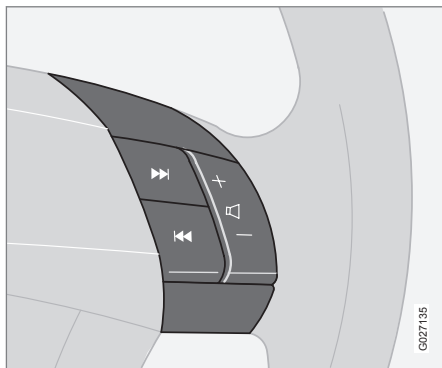

The four buttons on the steering wheel keypad can be used to control the audio system. The steering wheel keypad can be used to adjust volume, shift between preset stations and change CD tracks.

- Press the or buttons briefly to search for a radio station, or to go to the next/previous track on a CD.
- Press and hold down these buttons to search within a track.

Accessing and using menus

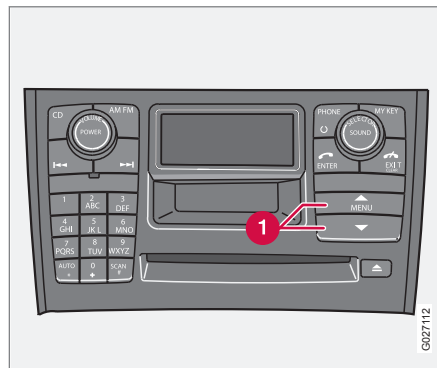

In menu mode, you can change settings and program new functions in the audio system. The various menu alternatives are shown in the display, and the current level in the menu structure is shown at the upper right corner of the display.

Press the **MENU** button to enter menu mode.

Use the menus as follows:

- Use the menu arrow keys (1) to navigate up or down in the menus. Dots in the display indicate that there are more menu selections from which to choose.
- Press **ENTER** to confirm or cancel a menu selection.

- One long press on **EXIT/CLEAR** exits menu mode.
- A short press on the **EXIT/CLEAR** enables you to cancel, undo, or answer no to a menu selection, or to go back in the menu structure.

Shortcut

The menu alternatives are numbered and can be accessed directly by pressing the respective keys on the numbered keypad on the left side of the audio panel.

MY KEY – programming a shortcut

Use the **MY KEY** button to program a favorite function from the menu, such as **RANDOM**, etc.

1. Use the **MENU** buttons to scroll among the functions.
2. Select the desired function from the menu by pressing the **MY KEY** button for more than two seconds.
3. When **MY KEY STORED** is shown in the display, the function has been stored.
4. Activate the function by briefly pressing the **MY KEY** button.

Repeat steps 1 – 4 to store new functions on the **MY KEY** buttons.



Audio system controls

NOTE

The **MY KEY** buttons can only be programmed for one shortcut function at a time.

Rear headphone connectors and controls *

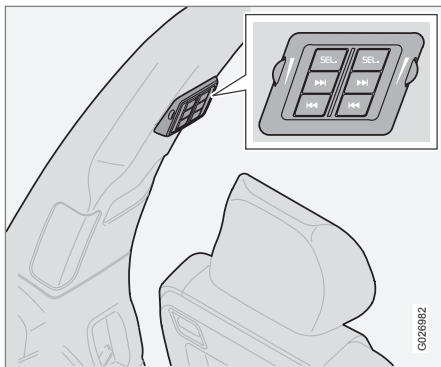

The door panels behind the second row of seats can be equipped with headphone connectors for passengers in the second and third row of seats. Several people can listen to different sound sources, such as CDs or the radio at the same time without disturbing each other.

Two sets of headphones can be plugged into each connector.

1. With the audio system switched on, use the **SEL** button to select a sound source.
2. Press the arrow keys briefly to change CD tracks or switch between preset stations.
3. Hold down the arrow keys to fast forward/reverse, or search for the previous/next strong radio station.
4. Hold down the **SEL** button to turn off the sound.

NOTE

For the best sound reproduction, we recommend headphones with impedance between 16 – 32 ohm. The sensitivity of these should be equal to or greater than 102 dB. The headphone connections are intended for 3.5 mm contacts and are located under the lower edge of the socket.

All headphones are automatically turned off when the ignition is switched off. They must be manually restarted when the ignition is switched on again.

Headphones – limitations

- The headphones will only work when the ignition key is in position I or higher.
- If a set of headphones is connected to the same source that is being sent through the speakers, the headphone controls cannot be used to change track or station. This is to prevent the driver from being distracted by an unexpected change in music.
- If the driver selects the same sound source as someone listening to this source through headphones, the driver takes control of the sound source.
- Only one disc in the optional CD changer, and one track on the CD can be played at a time.
- Headphone users can choose from among the preset radio stations (AM, FM1, FM2) previously set by the driver.
- If FM is played in the speakers, AM is not available and vice versa.



Audio system controls

On/Off button

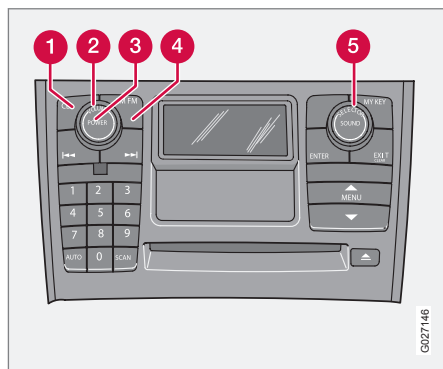

To activate the system:

1. Turn the ignition key to position I.

i NOTE

If you switch off the ignition while the audio system is on, the system will be on when the ignition is switched on again.

2. Press the **POWER** button (3) to switch the audio system on or off.

Volume control

Turn the knob (2) clockwise or counterclockwise to raise or lower the volume. The volume control is electronic and has no end position. Volume can also be raised (+) or lowered (-) using the steering wheel keypad.

Pause mode

If the volume is turned off, the CD player will go into pause mode. Re-activate the player by turning up the volume.

Selecting a sound source

- Press **AM/FM** (4) repeatedly to toggle between FM1, FM2, and AM
- Press the **CD** button (1) to change to the CD player or optional CD changer
- Turn the **SELECTOR** control (5) to choose FM1, FM2, AM, CD, CD changer*, AUX*, SiriusXM™ satellite radio* or BT¹ (see page 268).

The selected sound source will be shown in the display.

Sound settings

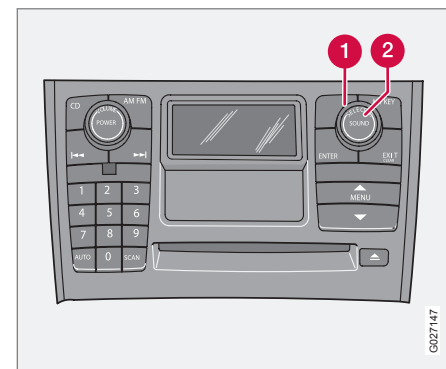

1. Press the **SOUND** button (2) repeatedly until you come to the setting that you wish to change. Choose **BASS**, **TREBLE**, **FADER**, **BALANCE**, **CENTER** or **SURROUND***
2. Use the **SELECTOR** control (1) to adjust the level of the setting you have selected. The display shows a scale from min. to max. position. The center indicates the normal position.

¹ Bluetooth® streaming audio



Audio system controls

NOTE

Sound level for the center speaker can only be set if Dolby Pro Logic II (**DPL II**) or three-channel stereo (**3-CH**) is selected in the menu.

Setting	Shown in the display
Bass	BASS
Treble	TREBLE
Balance between the right and left speakers	BALANCE
Balance between the front and rear speakers	FADER
Center speaker level	CENTER (Premium Sound system only)
Surround sound level	SURROUND OFF (Premium Sound system only)

SURROUND MODE

Surround sound settings are used to balance sound levels throughout the vehicle. Surround settings for the various sound sources are made separately.

There are three settings for surround sound.

- PRO LOGIC II
- 3-CHANNEL
- OFF (2-channel stereo)

The symbol in the display indicates that Dolby Surround Pro Logic II is activated.

- Dolby Surround Pro Logic II functions in CD mode only.
- **2-channel stereo is recommended for AM/FM radio broadcasts.**
- Dolby Surround Pro Logic II is only available on the highest level audio system – Premium Sound.

Use the following instructions to select PRO LOGIC II, 3-CHANNEL, or to turn these functions off. See also the menu structure on page 273.

1. Select **AUDIO SETTINGS** in the menu and press **ENTER**.
2. Select **CD SURROUND** and press **ENTER**.

3. Select **PRO LOGIC II, 3-CHANNEL**, or **OFF** and press **ENTER**.
4. The symbol **PL II** is displayed when Pro Logic II is selected.
5. **3-CH** is displayed when 3-channel stereo is selected.
6. **OFF** indicates normal stereo mode.

Dolby noise reduction is manufactured under license from Dolby Laboratories Licensing Corporation.

"Dolby Surround Pro Logic II", and the double-D symbol are trademarks of Dolby Laboratories Licensing Corporation. Dolby Surround Pro Logic II is manufactured under licence from Dolby Laboratories Licensing Corporation.

Equalizer

Equalizer FR EQ – FRONT (certain audio systems)

This function is used to fine-tune the sound from the front speakers.

1. Select **AUDIO SETTINGS** in the menu and press **ENTER**.
2. Select **Equalizer FR** and press **ENTER**.



Audio system controls

3. Use the menu selection buttons to set the level or use the **SELECTOR** control.
4. Press **ENTER** to select the next frequency. You can select five frequencies.
5. Press **ENTER** until you come to the menu mode to save the changes you have made.

Equalizer RR

EQ – REAR (certain audio systems)

This function is used to fine-tune the sound from the rear speakers.

1. Select **AUDIO SETTINGS** in the menu and press **ENTER**.
2. Select **EQ- REAR** and press **ENTER**.
3. Use the menu selection buttons to set the level or use the **SELECTOR** control.
4. Press **ENTER** to select the next frequency. You can select five frequencies
5. Press **ENTER** until you come to the menu mode to save the changes you have made.

Optimal sound reproduction

The audio system is calibrated for optimal sound reproduction through the use of digital signal processing. This calibration takes into account the speakers, amplifier, cabin acoustics, the seating position of the listener, etc.,

for each combination of vehicle and audio system. There is also dynamic calibration that takes into account the setting of the volume control, radio reception, and the vehicle's speed. The sound settings described in this manual, such as **BASS**, **TREBLE**, and **EQUALIZER** are only intended to enable the user to adapt sound reproduction to his/her personal preferences.



Radio functions

Station search

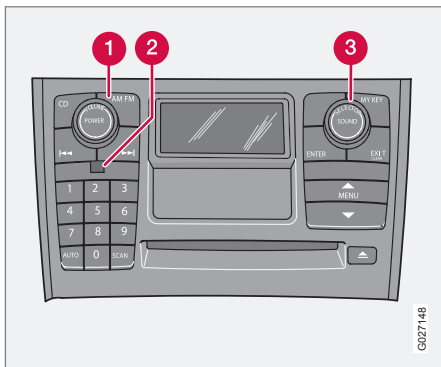

1. Choose radio mode AM/FM1/FM2 using the **SELECTOR** control (3) or the **AM/FM** button (1).
2. Press briefly on or to search for the next strong station. The radio will search for the next audible station and then stop.
3. Press one of the buttons again to start a new search.

Manually search for a known frequency

1. Press and hold the or button (or the corresponding buttons on the steering wheel keypad). **MAN** will be

shown in the display. The radio will slowly scroll in the desired direction and then increase speed after a few seconds.

2. Release the button when the desired frequency is displayed.
3. If you need to adjust the frequency, press briefly on or .

The manual search function is available for five seconds after you last pressed the button.

Storing stations

To store a selected station under one of the station setting buttons 0 – 9 (2):

1. Set the desired station.
2. Press the button under which the station is to be stored and keep it depressed. The sound will be interrupted for several seconds and **STATION STORED** is shown in the display. The station is now stored.

You can store up to 10 stations each for AM, FM1 and FM2, i.e. a total of 30 stations.

Frequency ranges

Radio	Frequency band
FM	87.7 – 107.9 MHz
AM	530 – 1710 kHz

Automatically storing stations – AUTOSTORE

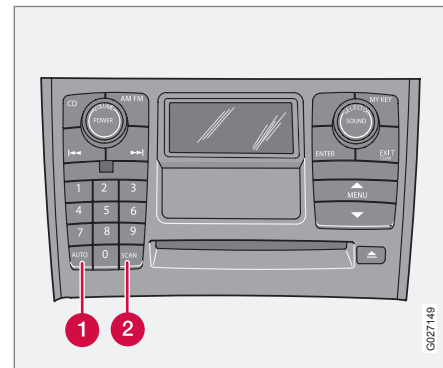

This function automatically searches for, and stores up to 10 strong AM or FM stations in a separate memory. If more than 10 stations are found, the 10 strongest ones will be stored. The function is especially useful in

**Radio functions**

areas in which you are not acquainted with radio stations or their frequencies.

Starting autostore

1. Choose a frequency band with the **AM/FM** button.
2. Press and hold down the **AUTO** button (1) until **AUTOSTORING** is shown in the display.

When **AUTOSTORING** is no longer displayed, the autostore process is complete. The automatically stored stations can be selected with the preset (number) keys. If there are no stations with sufficient signal strength, **NO AST FOUND** is displayed.

Stopping autostore

Press **EXIT**.

Selecting an autostored station

1. Press **AUTO** (1) briefly. **AUTO** will be displayed.
2. Press one of the preset buttons (0 – 9).

The radio will remain in Autostore mode until **AUTO**, **EXIT**, or **AM/FM** is pressed.

SCAN

This function automatically searches the currently selected waveband (AM, FM1, or FM2) for strong stations. When the radio finds a station, it will pause for approximately 8 seconds, after which it will continue scanning.

Activating/deactivating Scan

1. Choose a waveband by pressing the **AM/FM** button.
2. Press **SCAN** (2). **SCAN** will be shown in the display.
3. Press **EXIT** to stop scanning.

Storing a station found by SCAN

Stations can be stored on the preset buttons while the **SCAN** function is activated.

- Press a preset button and hold it down until Station stored is displayed.

This deactivates **SCAN** and the stored station can be selected by pressing the preset button.

Radio text

Certain stations broadcast program information, which can be shown in the display.

1. Press the **MENU** button.
2. Select **RADIOTEXT** in the menu and press **ENTER**.

Select **RADIOTEXT** again to deactivate.



Radio functions

HD Radio™ reception (U.S. models only)¹

Introduction

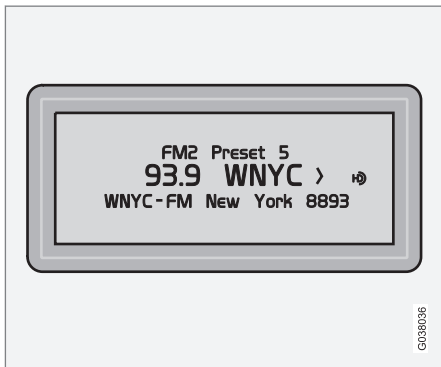

Display when the radio is receiving an HD Radio broadcast

HD radio is a brand name registered by the Ibiquity digital corporation². They are the developer of a broadcasting technology called IBOC or In Band On Channel, which refers to the method of transmitting a digital radio broadcast signal centered on the same

frequency as the AM or FM station's present frequency.

The IBOC system is referred to as a "hybrid" since it is both analogue and digital. During hybrid operation, receivers still continue to receive the analogue (non-digital) signal. HD radio receivers incorporate both modes of reception, where the receiver will automatically switch to the analogue signal if the digital signal cannot be decoded or is lost by the receiver. When you have tuned to an HD Radio station, the  symbol will appear in the audio system display.

More information about HD radio and IBOC can be found on Ibiquity's website, www.hdradio.com and www.ibiquity.com.

Benefits of digital broadcasting

- Better sound (FM sounds near CD quality and AM as analogue FM).
- Some FM frequencies offer a greater number of listening choices through "multicasting" (consisting of a frequency's main channel and any sub-channels that may also be available on that particular frequency. See also the section "Sub-channels" below).

- When receiving a digital signal there is no multipath disturbance or hisses/pops/crackling due to outside influences.

How HD broadcasting works

HD Radio works similarly to conventional radio and broadcasts of this type are available in many areas of the United States. However, there are a few key differences:

- Instead of transmitting one analogue signal, stations send out a bundled signal – both analogue and digital.
- An HD radio receiver can receive both digital and analogue broadcasts. Depending on the terrain and location of the vehicle (which will influence the signal strength), the receiver will determine which signal to receive.

Limitations

- **Main channel vs. sub-channels (FM only):** The main channel is the only channel that can receive in hybrid mode (both digital and analogue). If a frequency has sub-channels, they are broadcast in digital mode only. The main FM channel will be displayed as, for example, 93.9 WNYC (Volvo uses the symbol > to indicate there are sub-channels available) The sub-FM

¹ HD Radio(TM) technology is manufactured under license from iBiquity Digital Corp. U.S. and Foreign Patents. HD Radio(TM) and the HD and HD Radio logos are proprietary trademarks of iBiquity Digital Corp. HD Radio(TM) is only available in vehicles not equipped with the optional integrated CD changer.

² HD Radio (TM) technology is manufactured under license from iBiquity Digital Corp. U.S. and Foreign Patents. HD Radio(TM) and the HD and HD Radio logos are proprietary trademarks of iBiquity Digital Corp.



Radio functions

channels will be displayed as 93.9 – 2 WNYC, 93.9 – 3 WNYC, etc.

- **Reception coverage area:** Due to current IBOC transmitter power limitations, the reception coverage area in digital mode is somewhat more limited than the station's analogue coverage area. Please be aware that as with any radio broadcast technology, terrain, time of day, foliage level and building location can have positive or negative effects on radio reception.
- **Analogue to digital/digital to analogue blending:** Analogue to digital blending will occur as the signal strength reaches a preset threshold in the receiver. This will be noticeable in fringe areas (areas with weak reception) and is normal.

NOTE

There may be a noticeable difference in sound quality when a change from analogue to digital or digital to analogue occurs, such as:

- Volume increase or decrease
- Equalizer settings, i.e., Bass/ Mid-range/Treble cut or boost
- Time alignment (Digital program material in extreme cases can be as much as 8 seconds behind the analogue). This will be noticeable as a "stuttering" effect.

The above items are dependant on the broadcaster's equipment settings and do not indicate a fault in the vehicle's radio receiver or antenna systems.

Switching HD on or off

The factory setting for HD radio is **on**. However, when driving through areas with weak HD signals (fringe areas), you may experience that the radio repeatedly switches between analogue/digital and digital/analogue reception. If this happens, it may be desirable to switch HD off. To do so:

1. Be sure the audio system is switched on and in AM or FM mode.
2. Press **MENU** in the center console control panel.

3. Press **ENTER** to turn HD off (the X will disappear from the box on the display screen).

This will disable the radio's capability to receive digital broadcasts but it will continue to function as a conventional (analogue) AM/FM receiver. Please note that when HD is switched off, it will not be possible to tune to sub-channels (see the following section for a more detailed explanation of sub-channels).

Repeat steps 2 and 3 above to reactivate HD (an X will appear in the box on the display screen).

Sub-channels

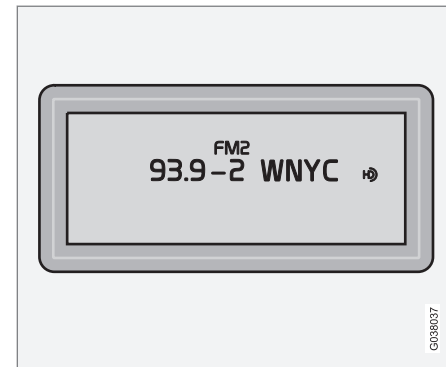

Example of an HD Radio station with sub-channels



Radio functions

In many cases, a main HD Radio station (FM wavebands only) will also have sub-channels offering additional types of programming or music.

In such cases, a number will be displayed to the right of the frequency number indicating that the currently tuned frequency has at least one sub-channel. The "2" in the illustration indicates that you are currently listening to the first sub-channel on frequency 93.9.

Selecting sub-channels

To listen to a station's sub-channel(s), press the right arrow key on the center console or on the steering wheel keypad. To go back to the main channel, press the left arrow key. To go to subchannel 2 (if available), press the right arrow key.

If you are currently tuned to a frequency's main channel, pressing the left arrow key will tune to the next lower radio frequency.



NOTE

- When the radio has gone into HD mode, it may take several seconds before the ">" symbol (if the current frequency has any sub-channels) is displayed to the right of the frequency. Pressing the arrow keys before the number is displayed will cause the radio to tune to the next available radio station, not to the current station's sub-channels.
- When you are no longer in broadcast-range of the currently tuned **sub-channel**, **No HD reception** will be displayed. The radio will then be muted and it will be necessary to tune to or search for a new radio station.

Sub-channels can also be stored as presets, see page 258 for information on storing stations.

If you press a sub-channel's preset button, it may take up to **6 seconds** before the channel becomes audible. If you press this button while you are out of digital range of the transmitter, **No HD reception** will be displayed.

**SiriusXM™ satellite radio****Listening to satellite radio**

The SiriusXM™ satellite system consists of a number of high elevation satellites in geosynchronous orbit.

NOTE

- The digital signals from the SiriusXM™ satellites are line-of-sight, which means that physical obstructions such as bridges, tunnels, etc. may temporarily interfere with signal reception.
- Avoid any obstructions, such as metallic objects transported on roof racks or in a ski box, or other antennas that may impede signals from the SiriusXM™ satellites.

Selecting SiriusXM™ radio mode

1. Press **Power** to switch on the audio system (see page 252 for information on the standard radio functions).
2. Turn the **SELECTOR** dial until Sirius 1 or 2 is displayed.

Activating SiriusXM™ radio

1. Tune to a satellite channel that has no audio, which means that the channel is unsubscribed and the text "**Call 888-539-SIRIUS TO SUBSCRIBE**" is

displayed (see also "Selecting a channel" in the right column).

2. Call SiriusXM™ at 1-888-539-SIRIUS (7474).
3. When asked for the SiriusXM™ ID number press **AUTO** to display this number. It is also possible to retrieve the SiriusXM™ ID from the **MENU**.
4. "**UPDATING SUBSCRIPTION**" will be displayed while the subscription is being updated, after which the display will return to the normal view.



SiriusXM™ ID

The SiriusXM™ ID is required when contacting the SiriusXM™ Call Center. It is used to activate your account and when making any account transactions. The SiriusXM™ ID is sometimes referred to as the Electronic Serial Number (ESN).

This function displays the 12-digit SiriusXM™ ID.

Selecting a channel category

1. Select SiriusXM™ radio mode as described above.
2. Press **ENTER**.

3. Use the up/down arrow keys to scroll through the list of categories.
4. Press **ENTER** to select a category.
5. Use the  and  buttons to select a channel in the currently chosen category.



NOTE

The category "All" is default, which enables you to scroll through the entire list of available satellite channels.

The channel categories are automatically updated several times a year. This takes approximately two minutes and will interrupt normal broadcasting. A message will be displayed while updating is in progress. Information on channel or feature updates is available at www.sirius.com.

Selecting a channel

There are two ways of tuning in a channel:

- By pressing and holding the  and  buttons to start the scroll function. The scrolling function begins slowly and increases speed after approximately 5 seconds. Release the button to listen to the currently displayed channel.
- Through direct channel entry



SiriusXM™ satellite radio

Direct channel entry

The SiriusXM™ satellite channels are numbered consecutively throughout all of the categories. To access a channel directly:

1. Press **MENU** and scroll to **Direct channel entry**.
2. Use the numerical keypad to enter the channel's number. Press **EXIT** if necessary to erase a digit.
3. Press **ENTER**. The radio will tune to this channel, even if it belongs to a category other than the currently selected one.

NOTE

The numbers of skipped or locked channels will not be displayed.

- If a channel is locked, the access code must be entered before the channel can be selected. See "Unlocking a channel" on page 266.

Scanning

SCAN automatically searches through the list of satellite channels. See page 259 for more detailed information.

Storing a channel

A total of 20 satellite channels can be stored; 10 channels each for SiriusXM™ 1 and 2. See page 258 for detailed information on storing channels.

- A **long** press on one of the number keys stores the currently tuned channel on that key.
- A **short** press on a number key while the radio is in SiriusXM™ 1 or 2 mode will tune to the preset satellite channel stored on that button, regardless of the currently selected channel category.

Song Seek and Song Memory

The **Song Seek** and **Song Memory** functions provide both audio and visual notification when SiriusXM™ is broadcasting your favorite songs. Song Seek enables you to store the name of the song for future advance notification when that song is being played. The **Song Memory** feature makes it possible to view all of the current songs that are stored in memory.

Song memory

Up to ten songs can be saved in the system's memory.

1. Press **MENU**.
2. Scroll to "**Add song to song mem.**" and follow the instructions shown in the display.

If a new song is selected when the memory is full, you will be prompted to press **ENTER** to delete the last song on the list.

The remaining songs in the list will move down one position, and the newly added song will be placed at the top of the list.

Song seek

When a satellite radio channel plays one of the songs stored in the song memory, the listener will be alerted by a text message and an audible signal.

Press **ENTER** to listen to the song or **EXIT** to cancel.

To activate/deactivate the song seek function:

1. Press **MENU**
2. Scroll to "**Song seek**"
3. Press **ENTER** to activate or deactivate the function.

**SiriusXM™ satellite radio****NOTE**

When the song has ended, the radio will remain tuned to the channel on which the song was played.

Radio text

The text that is displayed about the song currently playing can be changed. Use the **AUTO** button to switch between Artist, Title, Composer, or to switch radio text off, or use the menu to display and select among these categories.

Advanced settings

This menu function enables you to make settings on certain SiriusXM™ satellite radio functions. To access this menu:

1. Press **MENU**.
2. Select **Adv. settings**.

WARNING

Settings should be made when the vehicle is at a standstill.

The following settings can be made in the SiriusXM™ menu:

- Songs can be added to the song list
- Channel skip settings can be made
- Channel lock settings can be made
- The channel access code can be displayed or changed
- Your SiriusXM™ ID can be displayed

Skip options

This function is used to remove a channel from the list of available channels.

Skip current channel

1. Select **CHANNEL SKIP LIST** and press **ENTER**.
2. Select a category in the list and press **ENTER**.
3. Skip channels in the list presented by pressing **ENTER**.

Unskip all channels

This permanently removes all channels from the skip list and makes them available for selection.

Temp. unskip all ch.

This function will temporarily unskip all channels and make them available for selection. The channels remain on the skip list and will again be skipped the next time the ignition is switched on.

Channel lock

Access to specific channels can be restricted (locked). A locked channel will not provide audio, song titles, or artist information.

NOTE

All channels are initially unlocked at delivery.

Locking a channel:

1. Select **"Adv. settings"** in the menu and select **LOCK OPTIONS** and press **ENTER**.
2. Select **CHANNEL LOCK LIST** and press **ENTER**
3. Enter the channel access code¹ and press **ENTER**.
4. Select a category in the list and press **ENTER**.
5. Lock channels in the list presented by pressing **ENTER**.

The channel is now locked and a checked box will be displayed to indicate this. It will be necessary to enter the channel access code. See the section "Unlocking a channel" in order to listen to a locked channel.

¹ The default code is 0000. If you have changed the code and forgotten it, see the section "If you have forgotten the access code."



SiriusXM™ satellite radio

Unlocking a channel

A channel's access code¹ is required to unlock a channel.

Unlock all channels

This permanently removes all channels from the locked list and makes them available for selection.

Temp. unlock all ch.

This function will temporarily unlock all channels and make them available for selection. The channels remain on the locked list and will again be locked the next time the ignition is switched on.

CHANGE CODE

This function makes it possible to change the channel access code. The default code is 0000.

To change the code:

1. Select **CHANGE CODE** and press **ENTER**.
2. Enter the current code and press **ENTER**.
3. Enter the new code and press **ENTER**.
4. Confirm the new code and press **ENTER**.

If an incorrect code is entered, the text "**Incorrect code!**" is displayed.

If you have forgotten the access code

1. Select "**SIRIUS ID**" in the SiriusXM™ settings menu and press **ENTER**.
2. Press and hold the **ENTER** button for 2 seconds.

The current code will be displayed.

Your Volvo retailer can also provide you with assistance.

¹ The default code is 0000. If you have changed the code and forgotten it, see the section "If you have forgotten the access code."



Auxiliary equipment

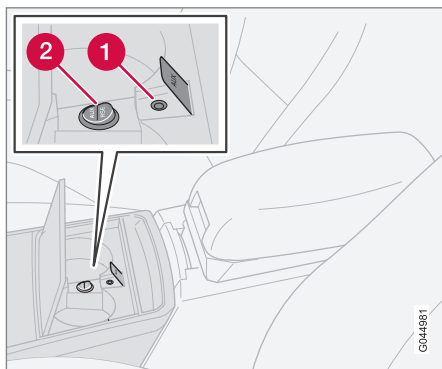

Auxiliary connector

- 1 AUX socket (3.5 mm)
- 2 Audio switch **AUX/RSE***

If the vehicle is equipped with Rear Seat Entertainment (RSE)*, an audio switch is located in the tunnel console for switching from **AUX** and **RSE**. The switch has two positions:

CAUTION

The cover over the cup holders should be open when a device is connected to the AUX socket.

- **AUX**: sound from an auxiliary device is heard from the audio system's speakers
- **RSE**: sound from the RSE system is heard from the audio system's speakers

AUX*

The **AUX** (auxiliary) port can be used to connect a device such as an MP3 player.

Turn the **SELECTOR** control (see the illustration on page 252) to choose **AUX**.

If the player is being charged through a 12-volt socket while it is connected to the **AUX** port, sound quality may be impaired.

The volume of the external sound source **AUX** may be different from the volume of the internal sound sources such as the CD player or the radio.

USB

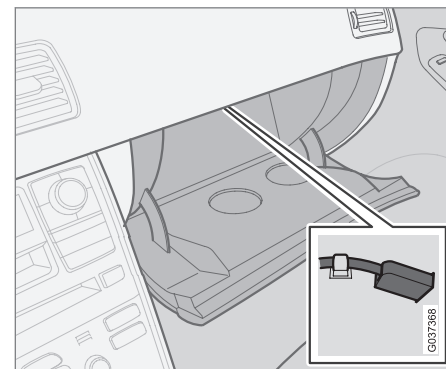

USB connector in glove compartment

If you connect an iPod®, MP3 player or a USB flash drive to the optional USB connector, this device can be controlled using the vehicle's audio controls.

NOTE

Be sure that the device and/or cable are in the glove compartment before closing the glove compartment door.



1. Select USB with the **SELECTOR** button.
 - > **Connect device** will be displayed.



Auxiliary equipment

2. Connect the iPod®, MP3 player or USB flash drive to the USB connector (see the illustration).
- > The text **Loading** will be displayed while the system loads the files (folder structure) on the device. This may take a short time.

When the information has been loaded, information about the tracks on the device will be displayed.

The  /  buttons can be used to fast forward/reverse or change tracks:

- Press briefly to change tracks.
- Press slightly longer to fast forward/reverse.

The arrow keys on the steering wheel keypad can also be used in the same way.

NOTE

- The system supports a number of iPod® models produced in 2005 or later.
- In order to help avoid damage to the USB socket, it will be switched off if there is a short circuit or if the connected device uses too much current (which can happen if the device does not comply with the USB standard). The USB socket will reactivate the next time the ignition is switched on if the problem no longer exists. If the problem persists, contact a trained and authorized Volvo service technician.

USB flash drive

To simplify the use of a USB flash drive, it is advisable to only store music files on the drive. It will take considerably longer for the system to index the files on the drive if it contains anything other than compatible music files.

NOTE

- The system supports removable media that uses the USB 2.0 standard and the FAT32 file system. It can index up to 1,000 folders and a maximum of 254 sub-folders/files for each folder. However, the highest folder level can support up to 1,000 sub-folders/files.
- When using a longer type of USB device, connecting it with a USB adapter cable will help reduce mechanical wear on the USB socket and on the device.

iPod®

An iPod® is charged and draws current if it is connected to the USB connector. However, if the battery is completely discharged, it should be charged before the iPod® is connected to the USB connector.

Bluetooth® streaming audio (BT)

The vehicle's audio system is equipped with Bluetooth®, which makes it possible to play streaming audio files from a Bluetooth®-connected cell phone. Navigation and control of the phone can be done through the vehicle's center console control panel or the steering wheel keypad. On certain cell phones, it is



Auxiliary equipment

also possible to change tracks from the phone itself.

In order to listen streaming audio, **BT** must be selected as a sound source (see page 255) and a Bluetooth® cell phone must be connected (paired) with the audio system. See page 275 for more information.



i NOTE

Any Bluetooth cell phones used must support Audio/Video Remote Control Profile (AVRCP) and Advanced Audio Distribution Profile (A2DP). The phone must use AVRCP version 1.3 and A2DP 1.2. If older versions of these standards are used, certain features (e.g., scan or random) may not function.

Not all cell phones are fully compatible with the vehicle's Bluetooth system. A list of compatible phones is available at your Volvo retailer or at www.volvocars.us.

Listening to streaming audio

Turn **SELECTOR** to select **BT** as the sound source.

The  /  buttons can be used to fast-forward/back or change tracks:

- Press briefly to change tracks.
- Press and hold to go fast-forward/back.

The buttons in the steering wheel keypad can be used in the same way.

Auxiliary sound level

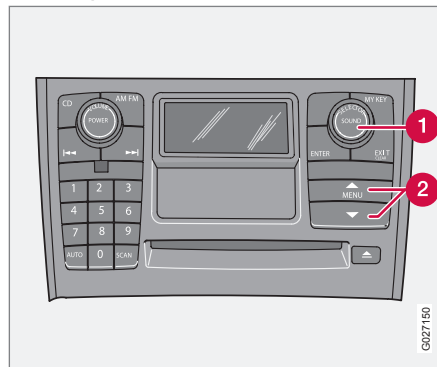

If the external sound source's volume is too high, the quality of the sound may be impaired.

This can be prevented by adjusting the external sound source's input volume.

1. While playing the radio or a CD, lower the audio volume to about one-quarter.
2. Switch to **AUX** mode on the audio system.

3. Connect the headphone output from your music player to the AUX input using a cable with a stereo 3.5 mm miniplug at both ends.
4. Set your music player's headphone volume to three-quarters using the player's volume controls.
5. Select **AUX VOLUME** in the menu and press **ENTER**.
6. Adjust the volume with **SELECTOR** (1) or with the up/down arrows (2) and press **ENTER**.
7. If there is distortion, lower your music player's headphone volume until the distortion goes away.

Finally, exit the menu and adjust the audio volume to a comfortable level.

i NOTE

This cannot be done with the steering wheel keypad.



CD player/changer

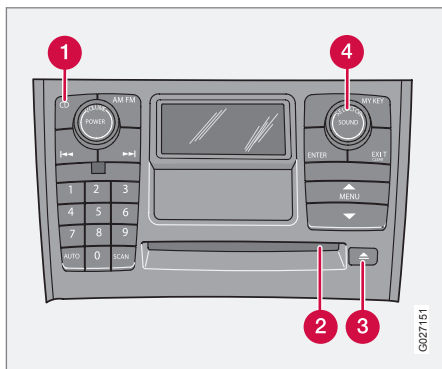

Playing a CD

CD player

If a CD is in the slot and the audio system is in CD mode when it is switched on, the CD will be played automatically. Otherwise, to play a CD:

1. Insert a CD into the slot (2).
2. Select the CD mode using the **SELECTOR** control (4) or the **CD** button (1).

CD changer*

The CD changer can hold up to six discs.

If a CD position in the changer containing a disc is selected, and the audio system is in

CD mode when it is switched on, the CD will play automatically. Otherwise, to play a CD:

1. Select an empty position using the station setting buttons 1 – 6. **INSERT DISC** will be displayed. Be sure this text is displayed before inserting a disc. The numbers of positions already containing discs are shown in the display.
2. Insert a CD into the slot (2).
3. Select the CD mode using the **SELECTOR** control (4) or the **CD** button (1).

Ejecting CDs

CD player

Press the EJECT button (3) to eject the CD.

CD changer

Ejecting one disc

A short press on the **EJECT** button (3) will eject the CD that is currently playing.

NOTE

For reasons of traffic safety, the ejected CD must be removed within 12 seconds or it will be automatically drawn back into the slot and the CD player will enter pause mode. Press the **CD** button to restart the disc.

Ejecting all discs

A long press on the **EJECT** button (3) starts the EJECT ALL function.

The text **EJECTING ALL** will be displayed and the entire magazine will be emptied disc by disc.

Pause

To pause CD playback, turn the volume all the way down. "**CD paused**" will be displayed. This will not occur if someone in the rear seat is listening to the CD through the optional headphones.

Play will resume when the volume is turned up again.

Audio files

In addition to playing normal music CDs, the CD player/changer can also play discs containing files in mp3 or wma format.

NOTE

Certain discs that are copy protected cannot be read by the player.

When a disc with audio files is inserted in the player, the player scans the disc's folders before it begins playing the files. The length of time that this takes depends on the quality of the disc.



CD player/changer

Navigating the disc and playing tracks

If a disc with audio files is in the CD player, press **ENTER** to display a list of folders on the disc.

Use the up and down arrows to move among the folders on the disc. Audio files have the





symbol and folders containing these

files have the  symbol.

Press **ENTER** to play a selected folder or a file.



When the music file has been played, the player will continue to play the rest of the files in the current folder. When all of the files in the folder have been played, the player will automatically go to the next folder and play the files in it.

NOTE



Press  or  if the entire name of the current track does not fit in the display.

Changing tracks

CD player/CD changer

1. Briefly press  or  to go to the next/previous track or file. The steering

wheel keypad can be used in the same way.

2. Press and hold down  or  to search within a track/file. The search continues as long as the buttons are depressed. The steering wheel keypad can be used in the same way.

SCAN

This function plays the first ten seconds of each track or file¹.

1. Press **SCAN** to begin scanning the tracks or files on the currently selected CD.
2. Press **EXIT/CLEAR** or **SCAN** to interrupt the scan function and listen to an entire track or file.

Random play

CD player

This function plays the tracks or files on a CD in random order (shuffle).

If a normal music CD is being played

Select **RANDOM** in the menu and press **ENTER**.

If a CD with mp3 or wma files is being played

Select **DISC** or **FOLDER** in the menu and press **ENTER**.

CD changer

This function offers two alternatives for playing the tracks on the disc(s) in the CD changer in random order (shuffle).

- **SINGLE DISC** (random order on the currently selected disc)
- **ALL DISCS** (random order on all of the CDs in the changer)

If a normal music CD is being played

- Select **RANDOM** in the menu and press **ENTER**.
- Select **SINGLE DISC** or **ALL DISCS** and press **ENTER**.

NOTE

Press to play the next randomly selected track. This can only be done on the currently selected disc.

If a CD with mp3 or wma files is being played

Select **SINGLE DISC** or **FOLDER** in the menu and press **ENTER**.

This function is deactivated when a new disc is selected.

¹ CD changer: SCAN only functions on the currently selected disc.



CD player/changer

Disctext

Certain CDs contain information about the disc, such as the titles of the tracks, etc. This information can be shown in the display by activating the **DISCTEXT** function.

1. Press the **MENU** button.
2. Select **DISCTEXT** in the menu and press **ENTER**.
3. Any information that may be stored on the disc will be displayed.

To deactivate this function, select **DISCTEXT** and press **ENTER**.

Compact disc care

- Do not put tape or labels on the disc itself. They could become stuck in the player.
- Use CD standard EN 60908 discs only. Discs not meeting this standard may cause problems with system (poor sound). CDR discs can cause listening problems due to the quality of the disc or recording equipment used.
- DualDisc: The audio side of a DualDisc (combined CD/DVD) does not meet CD specifications and may not play in your audio system.
- Keep the discs clean. Wipe them with a soft, clean, lint-free cloth, working from the center outwards. If necessary, dampen the cloth with a neutral soap solution. Dry thoroughly before using.
- Never use cleaning spray or antistatic liquid. Use only cleaners specifically made for CD's.
- Use discs of the correct size only (3.5" discs should never be used).
- Volvo does not recommend the use of plastic outer rings on the disc.
- Condensation may occur on discs/optical components of the changer in cold winter weather. The disc can be dried with a clean, lint-free cloth. Optical components in the CD changer may, however, take up to one hour to dry off.
- Never attempt to play a disc which is damaged in any way.
- When not in use, the discs should be stored in their covers. Avoid storing discs in excessive heat, direct sunlight or dusty locations.

**Menu structure****FM Menu****1. Radio Text****2. Audio Settings¹**

1. Surround
2. Equalizer Fr
3. Equalizer Rr
4. Reset All

AM Menu

See Audio Settings in the FM Menu.

CD Menu**1. Random****2. Disc Text****3. Audio Settings**

See Audio Settings in the FM Menu.

AUX Menu (option)**1. AUX input vol****2. Audio Settings**

See Audio Settings in the FM Menu.

¹ Certain audio systems



Bluetooth® hands-free connection

Introduction

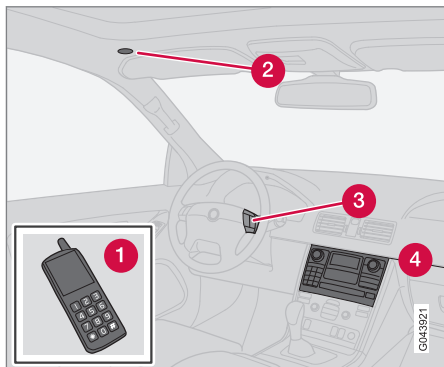

System overview

- 1 Cell phone
- 2 Location of the microphone
- 3 Steering wheel keypad
- 4 Center console control panel and display

Bluetooth® hands-free

This feature makes it possible to set up a wireless connection between a Bluetooth®-enabled cell phone and the vehicle's audio system. This enables the audio system to function as a hands-free connection and allows you to remote-control a number of the

phone's functions. The microphone used by this system is located in the roof lining near the sun visor (2). The buttons and other controls on the cell phone can always be used regardless of whether or not the phone is connected to the hands-free system.

NOTE

Not all cell phones are fully compatible with the hands-free system. A list of compatible phones is available at your Volvo retailer or at www.volvocars.us

WARNING

Never use the hands-free feature or any other device in your vehicle in a way that distracts you from the task of driving safely. Distraction can lead to a serious accident.

Overview of Bluetooth® controls

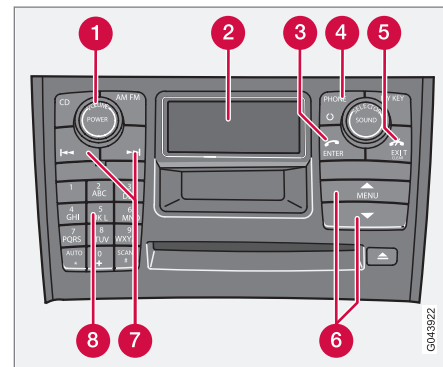

Center console control panel

- 1 **VOLUME:** the buttons on the steering wheel keypad can be also be used.
- 2 **Display**
- 3 **ENTER:** press to answer an incoming call, make menu selections or activate the phone from standby mode.
- 4 **PHONE:** press to turn standby on/off.
- 5 **EXIT:** press to end a call, reject an incoming call, go back in the menu system, cancel a selection or to erase numbers/letters that have been entered.



Bluetooth® hands-free connection

- 6 **MENU**: press to access the menu system. Press the arrow keys to go up or down among menu alternatives.
- 7 Search: go forward or back when entering text/numbers.
- 8 Alphanumeric keys and menu shortcuts.

Getting started

Use the controls in the center console (3) or the buttons in the steering wheel keypad to access, navigate and make selections in the hands-free system's menus (see page 278).

Activating/deactivating

A short press on the **PHONE** button in the center console activates the hands-free system. The text **PHONE** will appear at the top of the display to indicate that the audio system is in telephone mode.

The  symbol indicates that the hands-free system is active.

A long press on the **PHONE** button deactivates the hands-free system and disconnects the cell phone.

Connecting cell phones

The procedure for connecting a cell phone varies, depending on the phone itself, and on

whether or not the phone has been previously connected.

If this is the first time the phone is to be connected to the hands-free system, proceed as follows:

Alternative 1—using the vehicle's menus

1. Activate the cell phone's Bluetooth® function (refer to the phone's owner's manual if necessary) or go to www.volvocars.com
2. Activate the vehicle's Bluetooth® hands-free system by briefly pressing the **PHONE** button.
 - > **Add phone** will be displayed. If one or more cell phones are already registered in the system, they will also be displayed.
3. Select **Add phone**.
 - > The audio system will search for cell phones that are in range. This search takes approximately 30 seconds. Any phones detected will be displayed with their Bluetooth® names. The hands-free system's Bluetooth® name will appear in the cell phone's display as **My Volvo Car**.
4. Select one of the cell phones shown in the audio system's (center console) display.

5. Using the cell phone's keypad, enter the digits shown in the audio system's display.

Alternative 2—using the cell phone's menus

1. Activate the hands-free system by briefly pressing the **PHONE** button in the center console. If there is a cell phone connected, disconnect it from the hands-free system.
2. Perform a search using the cell phone's Bluetooth® function (consult the cell phone's owner's manual if necessary).
3. Select **My Volvo Car** in the list of devices shown in the cell phone's display.
4. When prompted, enter the PIN code 1234 in the cell phone.
5. Connect to **My Volvo Car** from the cell phone.

The cell phone will be registered and will be connected automatically to the audio system while the text **Synchronizing** is displayed. For more information on synchronizing a cell phone, see page 277.

When a connection has been established, the  symbol and the cell phone's Bluetooth® name will be displayed. The cell phone can now be controlled from the audio system.

**Bluetooth® hands-free connection****Making a call**

1. Ensure that **Phone** is shown at the top of the center console display and that the  symbol is visible (by pressing briefly on **PHONE** on the center console).
2. Dial the desired phone number or use the phone book (see page 277).
3. Press **ENTER**.
End the call by pressing **EXIT**.

Disconnecting the cell phone

The cell phone is automatically disconnected from the audio system if it is moved out of range. For more information about connections, see page 275.

The cell phone can be manually disconnected from the hands-free system by pressing **PHONE**. The hands-free system is also deactivated when the ignition is switched off.

When the cell phone is disconnected from the hands-free system, a call in progress can be continued using the cell phone's own speaker and microphone.

NOTE

Certain cell phones may require confirmation from the phone's keypad when a call is transferred from hands-free to the cell phone.

Handling calls**Incoming calls**

- Press **ENTER** to answer a call, even if the audio system is currently in e.g., CD or FM mode.
- Press **EXIT** to reject a call.

Automatic answer

This function means that incoming calls will be answered automatically. Activate or deactivate the function in the menu system under **PHONE MENU** → **CALL OPTIONS** → **Auto. answer**.

Call settings

While a call is in progress, press **MENU** or **ENTER** on the center console to access the following functions:

- **Mute microphone**: mute the audio system's microphone.
- **Transf call to cell**: transfer the call from hands-free to the cell phone.
- **Phone book**: this feature enables you to search for a stored telephone number.

**NOTE**

- On certain cell phones, the connection is broken when the mute function is used, which is normal. If this happens, the hands-free system will prompt you to reconnect.
- A new call cannot be initiated while another call is in progress.



Sound settings**Call volume**

Call volume can be adjusted while a call is in progress using the buttons in the steering wheel keypad.

Audio system volume

When **PHONE** is displayed, volume for the audio system can be adjusted in the normal way with the audio system's **VOLUME** control. In order to adjust volume during a phone call, the audio system must be switched to one of the other modes (FM, CD, etc).

Audio system sound can be automatically muted when a phone call is received in **PHONE MENU** → **PHONE SETTINGS** → **SOUNDS AND VOLUME** → **Mute radio**

and adjust the volume with the  /  keys on the center console.



Bluetooth® hands-free connection

Ringing volume

Go to **PHONE MENU** → **PHONE SETTINGS** → **SOUNDS AND VOLUME** → **Ring volume** and adjust the volume with the ▲ / ▼ keys on the center console.

Ringing tones

The hands-free system's integrated ringing tones can be selected in **PHONE MENU** → **PHONE SETTINGS** → **SOUNDS AND VOLUME** → **Ring signals** → **Ring signal 1**, etc.

NOTE

The connected cell phone's ring tone may not be switched off when one of the hands-free system's ringing tones is used.

If you prefer to use the connected cell phone's ring tone¹, go to **PHONE MENU** → **PHONE SETTINGS** → **SOUNDS AND VOLUME** → **Ring signals** → **Use cell phone signal**

¹ Not supported by all cell phones.

More information about registering and connecting cell phones

A maximum of 5 cell phones can be registered in the hands-free system. Registration only needs to be done once for each phone. After registration, the cell phones can then be found in the list of registered phones. Only one cell phone can be connected to hands-free at a time. Phones can be unregistered in **PHONE MENU** → **BLUETOOTH** → **Remove phone**.

Automatic connection

When the hands-free system is active and the most recently connected cell phone is within range, it is detected automatically. When the audio system searches for the most recently connected phone, this phone's name appears in the display. To manually connect a different cell phone, press **EXIT**.

Manual connection

To connect a phone other than the one that was most recently connected or to switch between cell phones that are already registered in the hands-free system:

Put the audio system in telephone mode (**Phone**) and follow the instructions in the display or change the connected cell by going

into the menu system under **PHONE MENU** → **BLUETOOTH** → **Change phone** → **Add phone**.

Phone book

In order to use the hands-free system's phone book (list of contacts), **PHONE** must be displayed at the top of the center console display and the  symbol must be visible.

The audio system stores a copy of the phone book of each registered cell phone. The phone book is automatically copied each time a phone is connected. This function can be activated in **PHONE SETTINGS** → **Sync phone book**. Searches for contacts are only made in the phone book of the currently connected cell phone.

NOTE

If a particular cell phone does not support copying of the phone book, **List is empty** will be displayed when copying has been completed.





If the phone book contains information about someone who is trying to call you, this information will be shown in the display.



Bluetooth® hands-free connection

Searching for contacts

The easiest way to search for a contact in the phone book is to press and hold any of the buttons **2–9** in the center console (no. 8 in the illustration on page 274). This starts a search based on the first letter on the button that has been pressed.

The phone book can also be accessed by pressing the navigation buttons  /  on the center console or by pressing  /  on the steering wheel keypad. A search can also be made in the phone book's search menu in **PHONE BOOK** → **Search**:

1. Enter the first letter of the contact's name and press **ENTER** or simply press **ENTER**.
2. Select the desired contact and press **ENTER** to make a call to that person.

Voice mail number

The phone number to your voice mail can be changed in the menu **CALL OPTIONS** → **Voice mail no.**. If no number has been stored, this menu can be accessed by a prolonged press on button **1**. Once a phone number has been stored, press and hold **1** to dial this number.

Call lists



Lists of calls in a particular cell phone are copied to the hands-free system each time that phone is connected. These lists are then updated while the phone is connected. Press **ENTER** to show the most recently dialed numbers. Other call lists can be found under **Call register....**

NOTE

Certain cell phones display the list of the most recently dialed numbers in reverse order.

Entering text

Text is entered by using the number buttons in the center console. Press a button once to enter the first letter on the button, twice to enter the second letter, etc. Continue to press the button to display other characters.

Press **EXIT** briefly to erase a character. Press and hold **EXIT** to erase all of the characters that have been entered. Use the  /  buttons on the center console to navigate among the characters.

Bluetooth® menus

1. CALL REGISTER

- 1.1. Last 10 missed calls
- 1.2. Last 10 received calls
- 1.3. Last 10 dialed calls

2. PHONE BOOK

- 2.1. Search
- 2.2. Copy to cell phone

3. BLUETOOTH

- 3.1. Change phone
 - 3.1.1. Add phone
 - 3.1.2–4. Added phones²

- 3.2. Remove phone
- 3.3. Connect fr. cell phone
- 3.4. Car Bluetooth info

4. CALL OPTIONS

- 4.1. Automatic answer
- 4.2. Voice mail number

5. PHONE SETTINGS

- 5.1. SOUNDS AND VOLUME
 - 5.1.1. Ring volume

² Max. 3 phones

**Bluetooth® hands-free connection**

5.1.2. Ring signals

5.1.3. Mute radio

5.2. Synchronize phone book

Label information.....	282
Dimensions	284
Weights	286
Fluids.....	288
Suspension.....	289
Engine oil.....	290
Engine specifications.....	291
Electrical system.....	292
Three-way catalytic converter.....	293
Overview of information and warning symbols	294
Volvo programs.....	296



11

SPECIFICATIONS

01 10
00 11

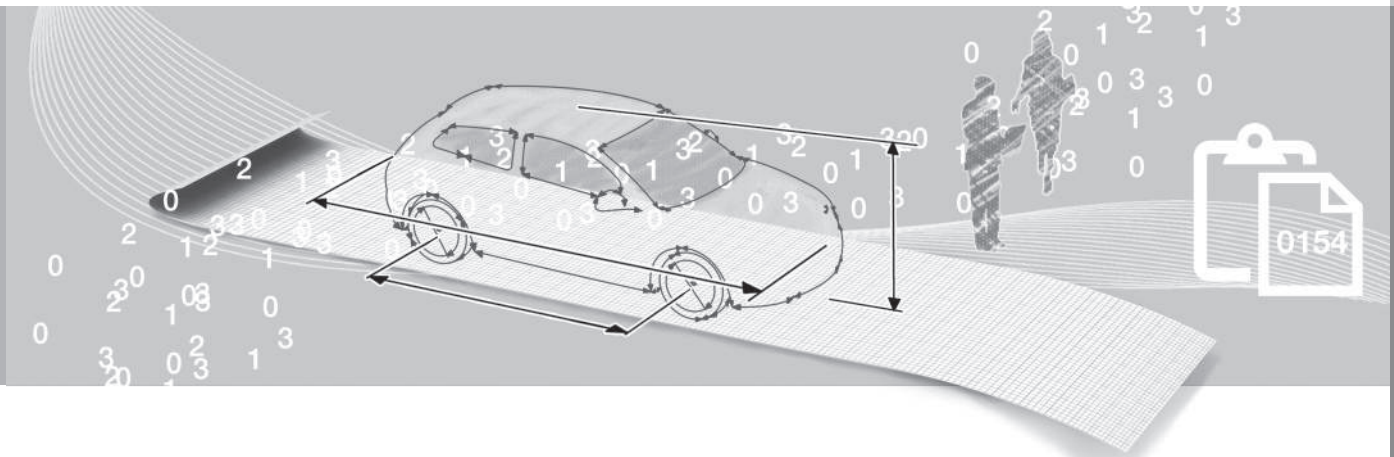

11 Specifications

Label information

11

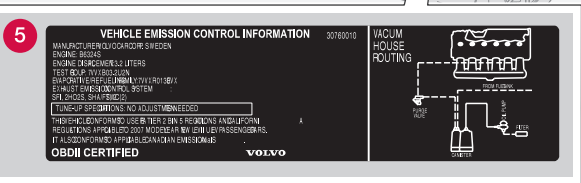
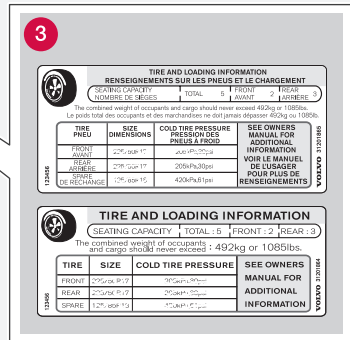
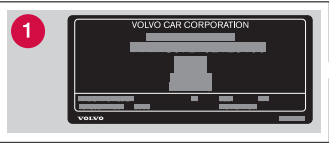
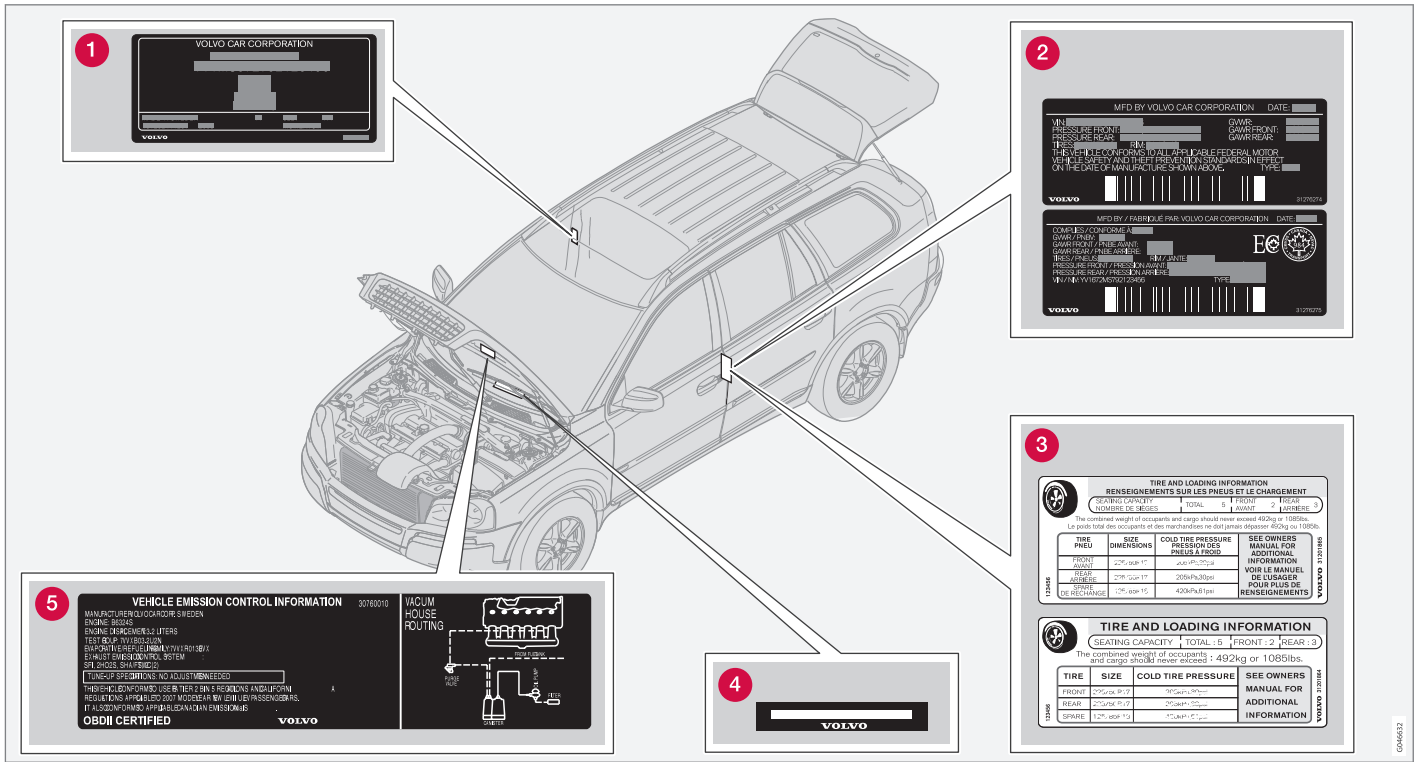

Label information

- 1 Model plate:** includes e.g., Vehicle Identification Number (VIN), codes for color and upholstery, etc. The model plate is located on the rear side of the B-pillar (the pillar between the front and rear passenger doors) and the rear passenger's door must be open in order to see it.
- 2 Federal Motor Vehicle Safety Standards (FMVSS) specifications (USA) and Ministry of Transport (CMVSS) standards (Canada):** Your Volvo is designed to meet all applicable safety standards, as evidenced by the certification label on the driver's side B-pillar (the structural member at the side of the vehicle, at the rear of the driver's door opening). For further information regarding these regulations, please consult your Volvo retailer.
- 3 Tire inflation pressures:** This label indicates the correct inflation pressures for the tires that were on the vehicle when it left the factory. Canadian models have the upper decal; U.S. models have the lower one.
- 4 Vehicle Identification Number (VIN):** The VIN plate is located on the top center of the dashboard at the base of the windshield. The VIN is also stamped on the right hand door pillar.
- 5 Vehicle Emission Control Information:** Your Volvo is designed to meet all applicable emission standards, as evidenced by the certification label on the underside of the hood. For further information regarding these regulations, please consult your Volvo retailer.

11 Specifications

Dimensions

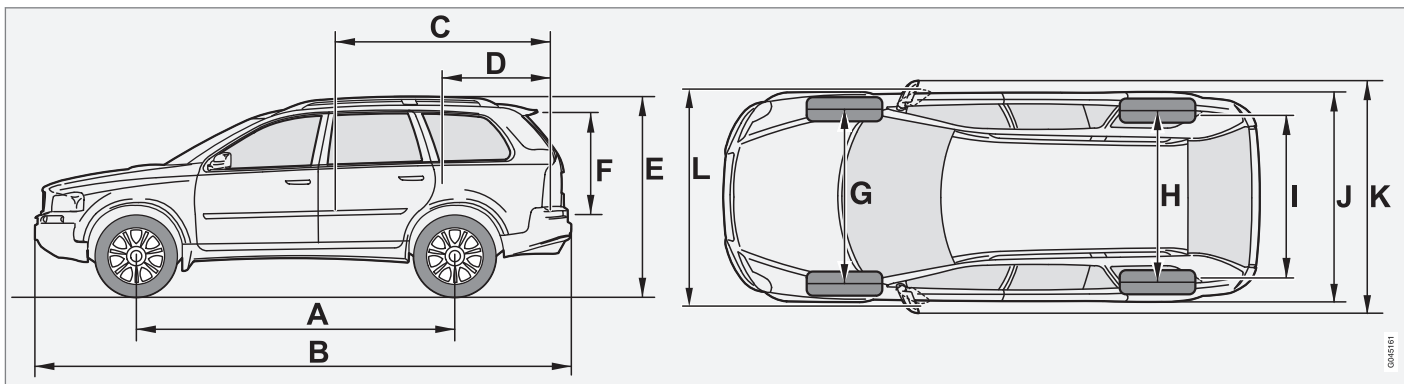

Position	Dimension	in (mm)
A	Wheelbase	112.6 (2857)
B	Length	189.3 (4807)
C	Load length, floor, seatback down	79.4 (2018)
D	Load length, cargo area	44 (1118)
E	Height	70.2 (1784)
F	Load height	34.3 (872)
G	Track, front	64.3 (1634)
H	Track, rear	63.9 (1624)

Dimensions

Position	Dimension	in (mm)
I	Load width, floor	41.8 (1064)
J	Width	76.2 (1936)
K	Width incl. door mirrors (folded out)	83.1 (2112)
L	Width incl. door mirrors (folded in)	76.2 (194)

Weights

Category	USA	Canada
Gross vehicle weight^A		
7-seat, 6-cyl, FWD ^B	5925 lbs	–
7-seat, 6-cyl, AWD ^C	6080 lbs	2760 kg
Capacity weight		
7-seat models	1210 lbs	550 kg
Permissible axle weight, front^A		
7-seat, 6-cyl, FWD	2770 lbs	–
7-seat, 6-cyl, AWD	2880 lbs	1310 kg
Permissible axle weight, rear^A		
7-seat, 6-cyl, FWD	3170 lbs	–
7-seat, 6-cyl, AWD	3240 lbs	1470 kg
Curb weight		
All models	4560 - 4790 lbs	2130 -2180 kg
Max. roof load	220 lbs	100 kg
Trailer weight, w/o brakes	1650 lbs	750 kg
Trailer weights, with brakes	See the table on page 164	See the table on page 164
Max. tongue weight	See the table on page 164	See the table on page 164

^A Permissible axle weight or gross vehicle weight must never be exceeded.

^B Front Wheel Drive

^C All Wheel Drive

Weights

CAUTION

The maximum permissible axle loads and/or the gross vehicle weight must not be exceeded.

WARNING

When adding accessories, equipment, luggage and other cargo to your vehicle, the total capacity weight must not be exceeded.

11 Specifications

Fluids

Specifications and capacities

Category	Specification
Fuel tank	21.1 US gals. (80 liters) Octane rating: unleaded gasoline, minimum octane requirement AKI 87, recommended rating AKI 91 or above (See also page 138)
Transmission oil^A TF-80SC	AW-1 7.4 US qts. (7.0 liters)
Miscellaneous Power steering Windshield washer reservoir Brake fluid Air conditioning system	Miscellaneous 1.1 US qts. (1.0 liters) 6.9 US qts. (6.5 liters) 0.63 US qts. (0.6 liters) Front – 2.2 lb. (1 kg), Rear* 2.9 lb. (1.3 kg) R 134a (HFC134a)
Coolant	Volvo original coolant/antifreeze (Thermostat begins to open at 194 ° F (90 ° C)). 7.9 US qts. (7.5 liters)
Brake fluid	DOT 4 boiling point >536 °F (280 °C)
Power steering fluid	Volvo synthetic power steering fluid (Pentosin CHF 11S) P/N 1161529 or equivalent 1.1 US quarts (1.0 liters)
Washer fluid reservoir	Use washer fluid solvent in cold weather conditions 6.9 US quarts (6.5 liters)
Air conditioning system	Refrigerant – R134a ^B

^A The transmission oil does not normally need to be changed during the service life of the vehicle. However, it may be necessary to replace the oil if the vehicle is often driven in areas of sustained temperature extremes (hot or cold), when towing a trailer over long distances, for prolonged driving in mountainous areas, or if the vehicle is often driven short distances in temperatures under 40 °F (5 °C).

^B See page 94 for volumes

Suspension**Rear suspension**

Individual rear wheel suspension with longitudinal support arms, double link arms and track rods.

Front suspension

Spring strut suspension with integrated shock absorbers and control arms linked to the support frame. Power-assisted rack and pinion steering. Safety type steering column.

Engine oil

Oil specifications

Engine oil must meet the minimum ACEA A5/B5. Lower quality oils may not offer the same fuel economy, engine performance, or engine protection.

Refer to the warranty and Service Records information booklet for information on oil change intervals and oil type requirements.

Volvo recommends Castrol.



NOTE

This vehicle comes from the factory with synthetic oil.

Engine designation	Volume ^A
3.2 6-cyl. B6324S5	7.18 US qts (6.8 liters)

^A Including filter replacement.

Engine specifications

Engine designation		B6324S5
Output		
	kW/rps	179/107
	hp/rpm	240/6400
Torque		
	Nm/rps	320/53
	ft. lbs./rpm	236/3200
No. of cylinders		6
Bore (mm/in.)		3.3/84
Stroke (mm/in.)		3.78/96
Cylinder displacement, liters		3.19 (194.8 cu in)
Compression ratio		10.8:1

Charge air cooler (Intercooler)

Turbocharged engines employ a turbo-compressor to force air into the engine inlet manifold and a charge air cooler to cool the compressed inlet air. The resulting increase in air flow raises pressure in the intake manifold and increases engine power over that developed by the normally-aspirated engine. The charge air cooler (which resembles a radiator) is located between the turbo-compressor and inlet manifold.

Fuel system

The engine is equipped with a multiport fuel injection system.

11 Specifications

Electrical system

General information

12-volt system with voltage controlled generator. Single wire system in which the chassis and engine block are used as conductors, grounded on the chassis.

Battery

Battery	3.2 6-cyl.
Voltage	12 V
Cold start capacity (CCA)	520 A
Reserve capacity (RC)	100 min
Capacity (Ah)	60

If you must replace your battery, be sure to replace it with a battery of the same cold start capacity and reserve capacity as the original. (See the decal on the battery).

WARNING

PROPOSITION 65 WARNING!

Battery posts, terminals, and related accessories contain lead and lead compounds, chemicals known to the state of California to cause cancer and reproductive harm. Wash hands after handling.

Three-way catalytic converter

Three-way catalytic converter - general information

- Keep your engine properly tuned. Certain engine malfunctions, particularly involving the electrical, fuel or distributor ignition systems, may cause unusually high three-way catalytic converter temperatures. Do not continue to operate your vehicle if you detect engine misfire, noticeable loss of power or other unusual operating conditions, such as engine overheating or backfiring. A properly tuned engine will help avoid malfunctions that could damage the three-way catalytic converter.
- Do not park your vehicle over combustible materials, such as grass or leaves, which can come into contact with the hot exhaust system and cause such materials to ignite under certain wind and weather conditions.
- Excessive starter cranking (in excess of one minute), or an intermittently firing or flooded engine can cause three-way catalytic converter or exhaust system overheating.
- Remember that tampering or unauthorized modifications to the engine, the Electronic Control Module, or the vehicle may be illegal and can cause three-way catalytic converter or exhaust system overheating. This includes: altering fuel injection settings or components, altering

emission system components or location, or removing components, and/the repeated use of leaded fuel.

NOTE

Unleaded fuel is required for vehicles with three-way catalytic converters.

Overview of information and warning symbols

Introduction

The symbols in the vehicle's various displays are divided into three main categories:

- Warning symbols
- Indicator symbols
- Information symbols







The following tables list the most common symbols, their meaning and the pages in this manual that provide more detailed information.







Warning/information symbol

This symbol () lights up and glows red if the condition is related to safety and/or drivability or yellow to alert the driver to e.g., fill the washer fluid reservoir, etc. In either case, a message will be displayed in the instrument panel display.

Symbols in the main instrument panel

Indicator and warning symbols

Symbol	Description	Page
	Warning	59
	Malfunction indicator light	61
	Fault in the ABS system	61
	Rear fog light	60
	Stability system DSTC	61
	Trailer turn signal indicator	61

Symbol	Description	Page
	Parking brake applied	60
	SRS airbag system	59
	Oil pressure warning light	60
	Seat belt reminder	59
	Generator warning light	60
	Brake failure warning light	60

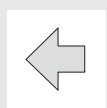
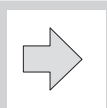

Overview of information and warning symbols





Symbol	Description	Page
	High beam indicator	58
	Left turn signal	58
	Right turn signal	58

Other information symbols



Symbol	Description	Page
	Cruise control	78

Information symbols in the center console display

Symbol	Description	Page
	Surround sound	256
	HD radio	260

Symbol	Description	Page
	Audio files	271
	CD folder	271
	Bluetooth-connected cell phone	275
	Bluetooth™ hands-free	275

Information symbols in the ceiling console

Symbol	Description	Page
	Seat belt reminder	56
	Occupant weight sensor	28

Volvo programs

Volvo On Call Roadside Assistance

Your new Volvo comes with a four year ON CALL roadside assistance. Additional information, features, and benefits are described in a separate information package in your glove compartment.

If you require assistance, dial:

In the U.S. 1-800-638-6586 (1-800-63-VOLVO)

In Canada 1-800-263-0475

Technician certification

In addition to Volvo factory training, Volvo supports certification by the National Institute for Automotive Service Excellence (A.S.E.). Certified technicians have demonstrated a high degree of competence in specific areas. Besides passing exams, each technician must also have worked in the field for two or more years before a certificate is issued. These professional technicians are best able to analyze vehicle problems and perform the necessary maintenance procedures to keep your Volvo at peak operating condition.

1, 2, 3 ...

 12-volt sockets..... 80
A

 A/C (air conditioning)..... 98, 99

ABS..... 155

Accessory installation warning..... 14

Airbag system..... 23

Air cleaner..... 221

Air conditioning..... 94

Air distribution..... 96, 99

Air quality sensor..... 98

Air vents..... 96

Alarm..... 133

All Wheel Drive..... 153

All Wheel Drive – towing..... 163

 Anti-lock brake system
 warning light..... 60

Anti-lock Brake System (ABS)..... 155

Ashtray..... 115

 Audio
 system introduction..... 252

 Audio system
 Bluetooth streaming audio..... 268
 HD digital radio..... 260
 SiriusXM™ satellite radio..... 263

AUTO (climate control)..... 99, 100

Automatic locking retractor..... 39

 Automatic transmission..... 149
 shiftlock override..... 23

Autostart..... 143, 145

AUX (audio system)..... 267

Average speed..... 76

AWD..... 153

B

 Bass..... 255

 Battery..... 219
 maintenance..... 227
 specifications..... 292

Battery – replacing..... 228

Belt check..... 220

Blind Spot Information System (BLIS)..... 171

Blower (fan)..... 100

Bluetooth cell phone connection..... 274

 Booster cushion
 accessory..... 48
 integrated..... 52

Brake fluid..... 225

 Brake system..... 154
 Brake pad inspection..... 154

 Bulbs..... 230
 specifications..... 236

Bulbs, replacing..... 230

C

 Capacities, fluids..... 288

Capacity weight..... 187

Cargo area cover..... 122

Cargo grid..... 121

Cargo net..... 119

Catalytic converter, three-way..... 293

CD Pause..... 270

Cell phone, hands-free connection..... 274

Center console buttons..... 64

Central locking system - remote key.....	127	Curb weight.....	187
Changing a wheel.....	200	Current fuel consumption.....	76
Changing coolant.....	220		
Charge air cooler.....	291	D	
Check Engine warning light.....	61	Daytime running lights.....	68
Child restraint anchors.....	49, 51	Defroster	
Child restraints		rear window and door mirrors.....	75
recalls and registration.....	40	rear window and mirrors.....	100
Child restraint systems.....	41	windshield.....	99
Child safety.....	38	Detachable trailer hitch.....	167
Child safety locks.....	132	Dimensions.....	284
Climate system.....	94	Disabling the passenger's side front air-	
refrigerant.....	94	bag.....	28
Clock reset button.....	58	Display, instrument panel.....	58
Coat hanger.....	117	Dolby Pro Logic II (DPL II).....	255
Cold weather precautions.....	169	Door mirrors.....	85
Compact disc care		defroster.....	75
CD care.....	272	Door mirrors, folding.....	64
Convertible seats.....	45	Driver distraction warning.....	14
Coolant.....	224	Driving conditions, difficult.....	147
changing.....	220	Driving economically.....	146
Courtesy light.....	111	Driving through water.....	147
Cup holder			
rear seat.....	116		

E

Economical driving.....	146
Electrically operated moonroof.....	87
Electrical system.....	292
Emergency locking retractor.....	39
Emission inspection readiness.....	217
Engine	
specifications.....	291
starting.....	143
Engine oil.....	222
checking.....	222
specifications.....	290
Environment.....	13

F

Federal Clean Air Act.....	216
Flat tires	
changing.....	198
repairing with tire sealing system.....	192
Floor mats	
cleaning.....	211
placing correctly.....	143
Fog light.....	60, 69

Folding door mirrors.....	64
Front airbags.....	24, 25, 28
Front seat	
folding backrest.....	104
manually adjusted.....	104
Front seats	
power.....	105
ventilated.....	97
XC90 Executive.....	107
Front suspension.....	289
Fuel.....	138
Fuel filler cap.....	141
Fuel filler door	
opening manually.....	141
unlocking.....	69
Fuel system.....	291
Fuses.....	238

G

Garage door opener	
HomeLink® Wireless Control System...	89
Gasoline.....	138
Geartronic – manual shifting.....	150

Generator.....	292
Generator warning light.....	60
Glove compartment.....	116
Grocery bag holder.....	122
Gross vehicle weight (GVW).....	187

H

Hand brake.....	157
Hazard warning flashers.....	75
HD digital radio.....	260
Headlights.....	67
Active Bending Lights.....	64, 67, 230
Dual Xenon.....	64
Headlights, high and low beams.....	71
Heated front seats.....	99
High/low beams – replacing.....	230
High beam bulb, replacing.....	232
High beam flash.....	71
High beam indicator.....	58
Hoisting the vehicle.....	219
HomeLink® Wireless Control System.....	89
Home safe lighting.....	71

Hood, opening/closing.....	81
----------------------------	----

I

Ignition switch.....	145
Immobilizer (start inhibitor).....	126
Important information.....	8
Indicator and warning symbols.....	58
indicator light.....	60
Infant seats.....	43
Inflatable Curtain.....	34
Inflation pressure, checking.....	181
Inflation pressure table.....	183
Information and warning symbols, table of.....	294
Information display.....	58
Inspection readiness.....	217
Instrument overview.....	56
Instrument panel.....	58
Instrument panel lighting.....	69
Interior lighting.....	111
ISOFIX/LATCH anchors.....	49

J

Jack.....	198
Jump starting.....	152

K

Key (ignition switch) positions.....	145
Keylock.....	11
Keys.....	126

L

Label information.....	282
Lighting panel.....	67, 68
Load carriers.....	168
Locking steering wheel.....	145
Locking the car.....	130
Locks, child safety.....	132
Long distance trips.....	169
Low beam headlight.....	71

M

Maintenance.....	216
Maintenance, periodic.....	217
Malfunction indicator light.....	61
Mirrors	
door, folding.....	64
power door.....	85
rearview, auto-dim function.....	84
Moonroof.....	87
Motor oil	
checking.....	222
MP3 player, connecting.....	267
Multifilter with air quality sensor.....	98

O

OBD II.....	217
Occupant safety.....	18
Oil	
checking.....	222
Oil quality.....	222
Onboard Diagnostic System (OBD II).....	217
On Call Roadside Assistance.....	296

Owner maintenance.....	217
------------------------	-----

P

Paint - color code.....	213
Panel lighting, instrument.....	69
Park assist.....	160, 161
Parking brake.....	157
warning symbol.....	60
Parking lights.....	69
Passenger's side front airbag, disabling...	28
Periodic owner-performed maintenance.	217
Permissible axle weight.....	187
Polishing.....	209
Power moonroof.....	87
Power seat.....	105
Power steering fluid.....	225

R

Radiator.....	221
Radio	
SiriusXM™ satellite radio.....	263

Radio functions.....	255
HD digital radio.....	260
Rain sensor - windshield wipers.....	73
Rear fog light.....	69
Rear suspension.....	289
Rearview mirror with compass.....	84
Rear window defroster.....	75
Recalls, child restraints.....	40
Recirculation.....	99
REDUCE SPEED.....	62
Refrigerant (A/C system).....	94
Refrigerator (XC90 Executive).....	118
Registering child restraints.....	40
Remote key.....	127
replacing the battery.....	129
Reporting safety defects.....	19

S

Safety defects, reporting.....	19
Safety locks, child.....	132
Seat belt.....	20

Seat belts	
Automatic locking retractor/Emergency locking retractor.....	39
Seats.....	104
Shiftlock.....	11, 143
override.....	23
Side impact protection (SIPS) airbags.....	32
SiriusXM™ satellite radio.....	263
Snow chains.....	190
Snow tires.....	190
Spare tire.....	191
Spare tire – accessing.....	198
Spare wheel, lowering.....	198
Speedometer.....	58
Starting the car.....	143
Start inhibitor (immobilizer).....	126
Steering wheel lock.....	145
Stone chips, touching up.....	213
Storage compartments.....	114, 116, 117
Studded tires.....	190
Sun visor.....	88
Symbols, overview.....	294

T

Tachometer.....	58
Tailgate	
locking/unlocking.....	131
opening.....	81
Tailgate wipers.....	226
Technician certification.....	296
Temperature control.....	100
Temperature gauge.....	58
Temporary spare tire.....	191
Three-way catalytic converter.....	293
TIME FOR REGULAR SERVICE.....	62
Tire inflation pressure.....	183
Tire Pressure Monitoring System (TPMS)	203
Tires.....	178
age.....	178
changing.....	198
changing from summer to winter.....	179
designations.....	184
improving economy.....	179
inflation.....	181
inflation pressure, checking.....	181
inflation pressure table.....	183
load ratings.....	182

rotation.....	178
Self-supporting run flat tires (SST).....	205
spare.....	191
speed ratings.....	182
storing.....	180
tire sealing system.....	192
tread wear indicator.....	179
Tire sealing system.....	192
Towing a trailer.....	164
Towing - cars with All Wheel Drive.....	163
Towing the vehicle.....	162
Trailer hitch - detachable.....	167
Trailer towing.....	164
Transmission	
shiftlock override.....	23
Transmission, automatic.....	149
Tread wear indicator.....	179
Treble.....	255
Trip computer.....	76
Trip odometer.....	58
Turn signals.....	71

U

Uniform Tire Quality Grading.....	189
Unlocking fuel filler door.....	69
Unlocking the car.....	130
Unpaved roads, driving on.....	147

V

Vanity mirror.....	112
Vehicle dimensions.....	284
Vehicle Identification Number (VIN).....	283
Vehicle loading.....	187
Vehicle maintenance.....	216
Vehicle weights.....	286
Ventilated seats.....	97
Volvo and the environment.....	13
Volvo maintenance.....	216
Volvo On Call Roadside Assistance.....	296

W

Warning symbol.....	58
Warning symbol in center of dashboard....	58
Warranties.....	216
Washer fluid reservoir.....	221, 224
Washing the vehicle.....	208
Water, driving through.....	147
Waxing.....	209
Weights.....	286
Wheels.....	178
storing.....	180
Windshield	
IR coating.....	74
Windshield washer fluid reservoir.....	224
Windshield wipers.....	226
Winter/Wet driving mode.....	169
Wipers.....	226
W - Winter.....	150

