



VOLVO S60

OWNER'S MANUAL



WEB EDITION

DEAR VOLVO OWNER

THANK YOU FOR CHOOSING VOLVO

We hope that you will enjoy many years of driving pleasure in your Volvo. The car has been designed for the safety and comfort of you and your passengers. Volvo is one of the safest cars in the world. Your Volvo has also been designed to satisfy all current safety and environmental requirements.

In order to increase your enjoyment of the car, we recommend that you familiarise yourself with the equipment, instructions and maintenance information contained in this owner's manual.





00 Introduction

| | |
|--------------------------------------|---|
| Introduction | 6 |
| Volvo Cars and the environment | 7 |

00



01 Safety

| | |
|---|----|
| Seatbelts | 12 |
| Airbag system | 14 |
| Airbags (SRS) | 15 |
| Activating/deactivating the airbag (SRS) | 18 |
| Side airbags (SIPS bags) | 20 |
| Inflatable Curtain (IC) | 22 |
| WHIPS | 23 |
| When the systems deploy | 25 |
| Child safety | 26 |

01



02 Instruments and controls

| | |
|---|----|
| Overview, left-hand drive car | 36 |
| Overview, right-hand drive car | 38 |
| Combined instrument panel | 40 |
| Indicator and warning symbols | 42 |
| Information display | 45 |
| Switches in the centre console | 46 |
| Lighting panel | 49 |
| Left-hand stalk switch | 51 |
| Trip computer | 52 |
| Right-hand stalk switch | 53 |
| Cruise control (option) | 55 |
| Steering wheel adjustment, parking brake | 56 |
| Electrical socket, cigarette lighter | 57 |
| Power windows | 58 |
| Rearview and door mirrors | 61 |
| Power sunroof (option) | 65 |

02



03 Climate control

| | |
|--|----|
| General information on climate control | 70 |
| Manual climate control, AC | 72 |
| Electronic climate control, ECC (option) | 74 |
| Air distribution | 77 |
| Fuel-driven heater (option) | 78 |



04 Interior

| | |
|---|----|
| Front seats | 82 |
| Interior lighting | 84 |
| Storage spaces in the passenger compartment | 86 |
| Rear seat | 91 |
| Cargo area | 92 |



05 Locks and alarm

| | |
|-------------------------------|-----|
| Keys and remote controls..... | 96 |
| Locking and unlocking | 99 |
| Child safety locks | 103 |
| Alarm (option) | 104 |



06 Starting and driving

| | |
|--|-----|
| General | 110 |
| Refuelling | 112 |
| Starting the car | 114 |
| Manual gearbox | 116 |
| Automatic gearbox | 117 |
| All-wheel drive – AWD | 121 |
| Brake system | 122 |
| Stability and traction control system, option | 124 |
| Active chassis – FOUR-C | 126 |
| Parking assistance | 127 |
| Towing and recovery | 129 |
| Start assistance | 131 |
| Driving with a trailer | 132 |
| Towing equipment | 134 |
| Detachable towbar | 136 |
| Load on the roof | 141 |
| Adjusting headlamp pattern | 143 |
| BLIS (Blind Spot Information System) – option | 149 |



07 Wheels and tyres

| | |
|---------------------------------------|-----|
| General | 156 |
| Tyre pressure | 159 |
| Warning triangle and spare wheel .. | 161 |
| Tyre pressure monitoring (option) ... | 163 |
| Changing wheels | 165 |
| Emergency puncture repair | 167 |



08 Car care

| | |
|-----------------------------|-----|
| Cleaning | 174 |
| Touching up paintwork | 177 |
| Rustproofing | 178 |

07

08



09 Maintenance and service

| | |
|----------------------------------|-----|
| Volvo service | 182 |
| Self-maintenance | 183 |
| Bonnet and engine compartment .. | 184 |
| Diesel | 185 |
| Oils and fluids | 186 |
| Wiper blades | 190 |
| Battery | 191 |
| Replacing bulbs | 193 |
| Fuses | 201 |



10 Infotainment system

| | |
|--|-----|
| Overview HU-450 | 212 |
| Overview HU-650 | 213 |
| Overview HU-850 | 214 |
| Audio functions HU-450/650/850 .. | 215 |
| Audio functions HU-450 | 216 |
| Audio functions HU-650/850 | 217 |
| Radio functions HU-450/650/850 .. | 218 |
| Radio functions HU-450 | 219 |
| Radio functions HU-650/850 | 220 |
| Radio functions HU-450/650/850 .. | 221 |
| Cassette player HU-450 | 226 |
| CD player HU-650 | 227 |
| Internal CD changer HU-850 | 228 |
| External CD changer HU-450/650/850 (option) | 229 |
| Dolby Surround Pro Logic II HU-850 | 230 |
| Technical data | 231 |
| Phone functions (option) | 232 |
| Call options | 235 |
| Memory functions | 238 |
| Menu functions | 239 |
| Miscellaneous information | 244 |



11 Technical data

| | |
|------------------------------|-----|
| Type designation | 248 |
| Dimensions and weights | 249 |
| Engine specifications | 251 |
| Engine oil | 253 |
| Fluids and lubricants | 256 |
| Fuel | 257 |
| Catalytic converter | 260 |
| Electrical system | 261 |



Introduction

Owner's Manual

A good way of getting to know your new car is to read the owner's manual, ideally before your first journey. This will give you the opportunity to familiarise yourself with new functions, to see how best to handle the car in different situations, and to make the best use of all the car's features.

Please pay attention to the safety instructions contained in the manual.



WARNING

"Warning!" texts indicate where there is a risk of personal injury in the event of the instructions not being followed.



IMPORTANT

"Important!" texts indicate a risk of damage to the car in the event of the instructions not being followed.

The equipment described in the owner's manual is not present in all models. In addition to standard equipment, this manual also describes options (factory fitted equipment) and certain accessories (extra equipment).



NOTE

Volvo cars are adapted for the varying requirements of different markets, as well as for national or local legal requirements and regulations. If you are uncertain over what is standard, an option or an accessory then contact your Volvo dealer.

The specifications, design features and illustrations in this owner's manual are not binding. We reserve the right to make modifications without prior notice.

Contact your Volvo dealer for more information.

© Volvo Car Corporation

Volvo Cars and the environment

Volvo Car Corporation's environmental philosophy



Environmental care, safety and quality are the three core values which influence all operations of the Volvo Car Corporation. We also believe that our customers share our consideration for the environment.

Your Volvo complies with strict international environmental standards and is also manufactured in one of the cleanest and most resource-efficient plants in the world. Volvo Car Corporation has global ISO certification, which includes the environmental standard (ISO 14001) covering factories, central func-

tions, as well as several of our other units. We also set requirements for our partners so that they work systematically with environmental issues.

EPI (Environmental Product Information) is supplied for all Volvo models. Here you can see how the environment is affected during the entire lifecycle of the car.

Read more at www.volvocars.com/EPI.

Fuel consumption

Volvo cars have competitive fuel consumption in each of their respective classes. Lower fuel consumption generally results in lower emission of the greenhouse gas, carbon dioxide.

It is possible for the driver to influence fuel consumption. For more information read under the heading Reducing environmental impact on page 9.



Volvo Cars and the environment

Efficient emission control

Your Volvo is manufactured following the concept **Clean inside and out** – a concept that encompasses a clean interior environment as well as highly efficient emission control. In many cases the exhaust emissions are well below the applicable standards.

In addition there is a special radiator coating, PremAir®¹, which can convert hazardous ground-level ozone into pure oxygen when the ozone passes the radiator. The higher the ozone content in the air the more ozone is converted.

Clean air in the passenger compartment

A passenger compartment filter prevents dust and pollen from entering the passenger compartment via the air intake.

A sophisticated air quality system, IAQS² (Interior Air Quality System) ensures that the incoming air is cleaner than the air in the traffic outside.

The system consists of an electronic sensor and a carbon filter. The incoming air is moni-

tored continuously and if there is an increase in the level of certain unhealthy gases such as carbon monoxide then the air intake is closed. Such a situation may arise in heavy traffic, queues and tunnels for example.

The entry of nitrous oxides, ground-level ozone and hydrocarbons is prevented by the carbon filter.

Textile standard

The interior of a Volvo is designed to be pleasant and comfortable, even for people with contact allergies and for asthma sufferers. All of our upholstery and interior textiles are tested with respect to certain unhealthy substances and allergens as well as emissions. This means that all textiles fulfil the requirements in the Öko-Tex 100 standard³, a major advance towards a healthier passenger compartment environment.

Öko-Tex certification covers seatbelts, carpets, thread and fabrics for example. The leather in the upholstery undergoes chromium-free tanning with natural plant substances and fulfils the certification requirements.

Volvo workshops and the environment

Regular maintenance creates the conditions for a long service life and low fuel consumption for your car, and in this way you contribute to a cleaner environment. When Volvo's workshops are entrusted with the service and maintenance of your car it becomes part of our system. We make clear demands regarding the way in which our workshops are designed in order to prevent spills and discharges into the environment. Our workshop staff have the knowledge and the tools required to guarantee good environmental care.

¹ Option for 5-cylinder engines.
PremAir® is a registered trademark of Engelhard Corporation.

² Option

³ More information on www.oekotex.com

Volvo Cars and the environment

Reducing environmental impact

You can easily help reduce environmental impact, for example, by driving economically, by purchasing eco-labelled car care products and by servicing and maintaining the car in accordance with the instructions in the owner's manual.

The following hints will help you to do your bit for the environment:

- Decrease fuel consumption by choosing ECO tyre pressure, see page 160.
 - Since a roof load and ski box increase air resistance, leading to significantly higher fuel consumption, they should be removed immediately after use.
- 
- Remove unnecessary items from the car - the greater the load the higher the fuel consumption.
 - Is your car equipped with an engine block heater? If so, use it for a few hours before starting from cold to reduce fuel consumption and exhaust emissions.
 - Drive gently and avoid braking too hard.

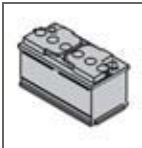
- Drive in the highest gear possible. Low engine speeds result in lower fuel consumption.
- 
- Ease back on the accelerator on downhill gradients.
 - Use engine braking to slow down.
 - Avoid idling. Take consideration of local regulations. Switch off the engine in longer stationary traffic.
 - Always dispose of environmentally hazardous waste, such as batteries and oils, in an environmentally responsible manner. If uncertain, consult an authorised Volvo workshop for advice.
- 
- Service your car regularly.
 - High speed increases consumption considerably due to increased wind resistance. A doubling of speed increases wind resistance four times.

These hints will help you to reduce your fuel consumption without increasing your travel time or lessening the enjoyment of driving. Apart from being kind to your car, you'll be saving money - and the Earth's resources.

| | |
|---|----|
| Seatbelts | 12 |
| Airbag system | 14 |
| Airbags (SRS) | 15 |
| Activating/deactivating the airbag (SRS) | 18 |
| Side airbags (SIPS bags) | 20 |
| Inflatable Curtain (IC) | 22 |
| WHIPS..... | 23 |
| When the systems deploy | 25 |
| Child safety | 26 |

SAFETY



01



Seatbelts

Always use a seatbelt



Tensioning the hip strap. The belt must be positioned low down.

Heavy braking can have serious consequences if the seatbelts are not used, so make sure that all passengers use their seatbelts. It is important that the seatbelt lies against the body so it can provide maximum protection. Do not lean the backrest too far back. The seatbelt is designed to protect in a normal seating position.

Putting on a seatbelt

- Pull the seatbelt out slowly and secure it by pressing the buckle into the lock. A loud "click" indicates that the seatbelt has locked.

Releasing the seatbelt

- Press the red lock button and then let the seatbelt retract. If the seatbelt does not retract fully, feed the seatbelt in by hand so that it does not hang loose.

The seatbelt locks and cannot be withdrawn

- if it is pulled out too quickly.
- during braking and acceleration.
- if the car leans heavily.

Keep in mind the following:

- do not use clips or anything else that can prevent the seatbelt from fitting properly
- ensure that the seatbelt is not twisted or caught on anything
- the hip strap must be positioned low down (not over the abdomen).
- tension the hip strap over the lap by pulling the diagonal shoulder belt as illustrated

WARNING

The seatbelts and airbags interact. If a seatbelt is not used or is used incorrectly, this may diminish the protection provided by the airbag in the event of a collision.

WARNING

Each seatbelt is designed for only one person.

WARNING

Never modify or repair the seatbelt yourself. Contact an authorised Volvo workshop. If the seatbelt has been subjected to a major load, such as in a collision, the entire seatbelt must be replaced. Some of the seatbelt's protective properties may have been lost even if the seatbelt does not appear damaged. The seatbelt must also be replaced if it shows signs of wear or damage. The new seatbelt must be type-approved and designed for installation at the same location as the replaced seatbelt.



Seatbelts and pregnancy



The seatbelt should always be worn during pregnancy. But it is crucial that it be worn in the correct way. The diagonal section of the seatbelt should wrap over the shoulder then be routed between the breasts and to the side of the abdomen. The lap section of the seatbelt should lay flat over the thighs and as low as possible under the abdomen. It must never be allowed to ride upward. Remove all slack from the seatbelt and ensure that it fits close to the body. In addition, check that there are no twists in the seatbelt.

As a pregnancy progresses, pregnant drivers should adjust their seats and steering wheel such that they can easily maintain control of the vehicle as they drive (which means that they must be able to easily operate the foot pedals and steering wheel). They should strive to position the seat with as large a distance as possible between their abdomen and the steering wheel.

Seatbelt reminder

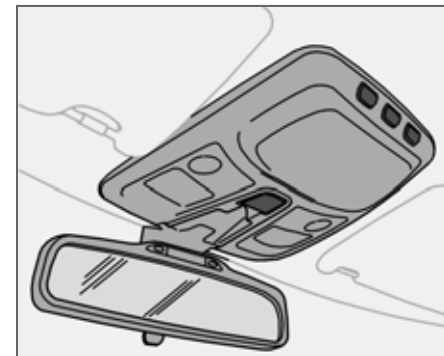

The seatbelt warning symbol in the combined instrument panel and above the rearview mirror illuminates until the driver buckles the seatbelt. The seatbelt reminder switches off after 6 seconds if speed is below 10 km/h.

If the driver has not buckled the seatbelt then the reminder switches on if speed exceeds 10 km/h and switches off if speed drops below 5 km/h. If the seatbelt is released, the function reactivates when speed exceeds 10 km/h.

The seatbelt reminder is intended for adults.



Airbag system

Seatbelt tensioner

All the seatbelts (except the centre rear seatbelt) are equipped with seatbelt tensioners. A mechanism in the seatbelt tensioner tightens the seatbelt in the event of a sufficiently violent collision. The seatbelt then provides more effective restraint for occupants.

Warning symbol in combined instrument panel

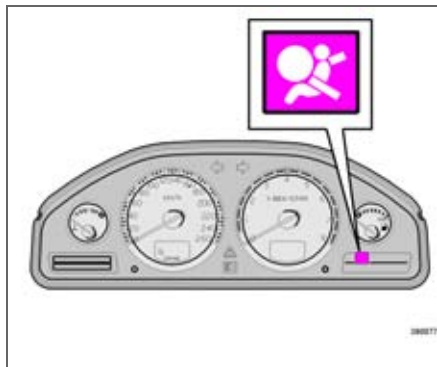

The airbag system¹ is continually monitored by the system control module. The warning symbol in the combined instrument panel illuminates when the ignition key is turned to position **I**, **II** or **III**. The symbol goes out after approx. 6 seconds provided the airbag system¹ is working correctly.



As well as the warning symbol, a message may appear on the display in appropriate cases. If the warning symbol malfunctions, the warning triangle illuminates and the message **SRS AIRBAG SERVICE URGENT** appears in the display. Contact an authorised Volvo workshop urgently.

WARNING

If the warning symbol for the airbag system remains on or illuminates while driving, it means that the airbag system does not have full functionality. The symbol can indicate a fault in the seatbelt tensioner system, SIPS, the SRS system or the IC system. Contact an authorised Volvo workshop immediately.

¹ Includes SRS and seatbelt tensioner, SIPS and IC.



Airbags (SRS)

Airbag (SRS) on the driver's side



The car has an SRS airbag (Supplemental Restraint System) in the steering wheel to supplement the protection afforded by the seatbelt. This airbag is fitted into the centre of the steering wheel. The steering wheel is marked **SRS AIRBAG**.

WARNING

The seatbelts and airbags interact. If a seatbelt is not used or is used incorrectly, this may diminish the protection provided by the airbag in the event of a collision.

Passenger airbag (SRS)

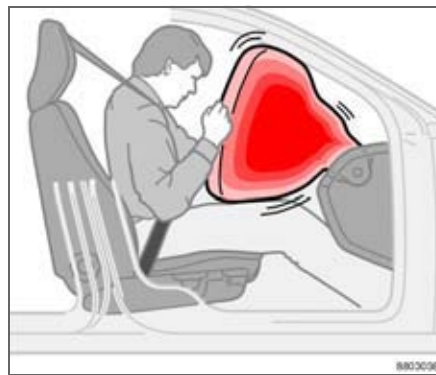

The car has an airbag to supplement the protection afforded by the seatbelt on the passenger side¹ and the airbag is folded up into a compartment above the glovebox. The cover panel is marked **SRS AIRBAG**.

WARNING

To minimise the risk of injury if the airbag deploys, passengers must sit as upright as possible with their feet on the floor and backs against the backrest. Seatbelts must be secured.

WARNING

Never place a child in a child seat or on a booster cushion in the front seat if the airbag (SRS) is activated¹.

Never allow a child to stand or sit in front of the front passenger seat. No one shorter than 140 cm should sit in the front passenger seat if the airbag (SRS) is activated.

Failure to follow the advice given above can endanger the life of the child.

¹For information on activated/deactivated airbag (SRS) see page 18.

¹ Not all cars have a passenger airbag (SRS). This can be unselected when the car is ordered.



Airbags (SRS)

SRS system

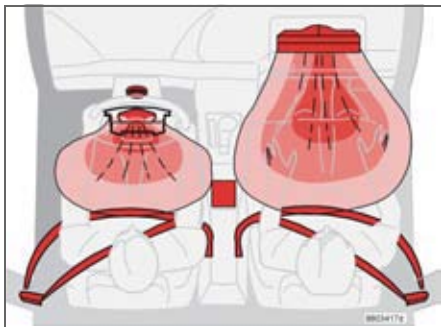

SRS system, left-hand drive.

The SRS system consists of airbags and sensors. A sufficiently violent collision trips the sensors and the airbag(s) are inflated with hot gas. To cushion the impact, the airbag deflates when compressed. When this occurs, smoke escapes into the car. This is completely normal. The entire process, including inflation and deflation of the airbag, takes place within tenths of a second.

 **WARNING**

Repairs must only be performed by an authorised Volvo workshop.

Work on the SRS system can cause malfunction and result in serious personal injury.

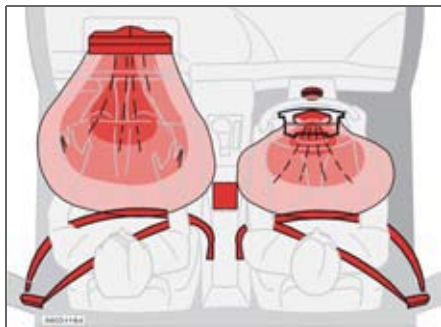

SRS system, right-hand drive

 **NOTE**

The sensors react differently depending on the course of the collision and whether the seatbelts on the driver and passenger sides are being used. It is therefore possible that only one (or none) of the airbags may inflate in a collision. The SRS system senses the force of the collision on the vehicle and adapts accordingly so that one or more airbags is deployed. The capacities of the airbags are also adapted to the collision force to which they are subjected.

 **NOTE**

The airbags have a function whereby their capacities are adapted to the collision force to which the car is subjected.



Location of the passenger airbag in left-hand drive and right-hand drive cars

**WARNING**

Do not put objects in front of or above the instrument panel where the passenger airbag is located.



Activating/deactivating the airbag (SRS)

PACOS (option)

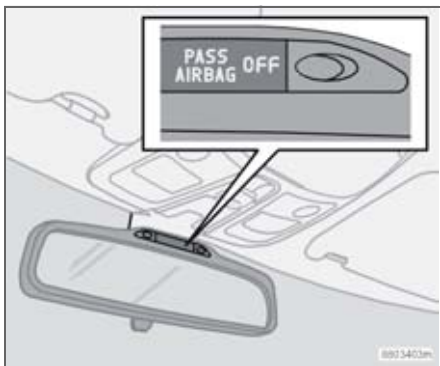

Indicator showing that the passenger airbag (SRS) is deactivated.

The airbag (SRS) for the front passenger seat can be deactivated if the car is equipped with PACOS, see page 19.

Message

A text message in the roof panel indicates that the airbag (SRS) for the front passenger seat is deactivated (see illustration above).

Activating/deactivating

The switch for the passenger airbag is located on the passenger end of the instrument panel and is accessible when the passenger

door is open (see under the heading, Switch – PACOS below).

Check that the switch is in the required position. Volvo recommends that the key blade be used to change position (other items with a shape similar to a key can also be used).

WARNING

Failure to follow the advice given above can endanger life.

WARNING

If the car is equipped with a front passenger airbag (SRS), but does not have PACOS, the airbag will always be activated.

WARNING

Never place a child in a child seat or on a booster cushion in the front seat if the airbag is activated. Failure to follow this advice can endanger the life of the child.

WARNING

Do not allow anyone to sit in the front passenger seat if the text message in the roof panel indicates that the airbag (SRS) is deactivated and the airbag system warning symbol is displayed in the combined instrument panel. This indicates that there has been a severe malfunction. Visit an authorised Volvo workshop urgently.



Activating/deactivating the airbag (SRS)

Switch - PACOS

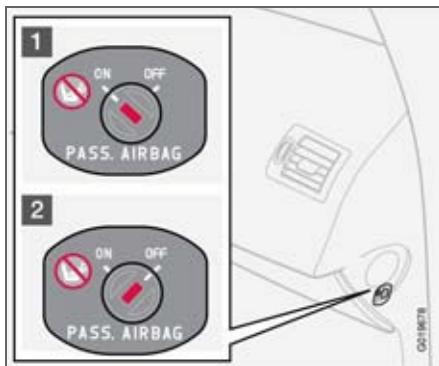

Switch location.

1. The airbag is activated. With the switch in this position, persons taller than 140 cm can sit in the front passenger seat, but never children in a child seat or on a booster cushion.
2. The airbag is deactivated. With the switch in this position, children in a child seat or on a booster cushion can sit in the front passenger seat, but never anybody taller than 140 cm.



WARNING

Activated airbag (passenger seat):
Never place a child in a child seat or on a booster cushion in the front passenger seat when the airbag is activated. This also applies to anyone shorter than 140 cm.

Deactivated airbag (passenger seat):
No one taller than 140 cm should ever sit in the front passenger seat when the airbag is deactivated.

Failure to follow the advice given above can endanger life.



Side airbags (SIPS bags)

Side airbags – SIPS bag



Side airbag locations.

A large proportion of the collision force is transferred by the SIPS (Side Impact Protection System) to beams, pillars, the floor, the roof and other structural parts of the body. The side airbags at the driver's and front passenger seats protect the chest area and are an important part of the system. The side airbags are located in the front seat backrests.

WARNING

Side airbags are a supplement the seatbelts. Always wear your seatbelt.

WARNING

Repairs must only be performed by an authorised Volvo workshop.

Work on the SIPS bag system could cause malfunction and result in serious personal injury.

WARNING

Do not put objects in the area between the outside of the seat and the door panel, since this area is required by the side airbag.

WARNING

Use only Volvo genuine car seat covers, or seat covers approved by Volvo. Other seat covers may impede the operation of the side air bags.

Child seats and side airbags

The side airbag does not diminish the protection provided by the car to children seated in a child seat or on a booster cushion.

A child seat or booster cushion can be placed on the front passenger seat provided that the car does not have an activated¹ passenger airbag.

¹ For information on activated/deactivated airbag (SRS) see page 18



Side airbags (SIPS bags)

SIPS bags



Driver's seat, left-hand drive

The SIPS bag system consists of side airbags and sensors. A sufficiently violent collision trips the sensors and the side airbags are inflated.



Front passenger seat, left-hand drive

The airbag inflates between the occupant and the door panel and thereby cushions the initial impact. The airbag deflates when compressed. The side airbag is normally only deployed on the side of the collision.

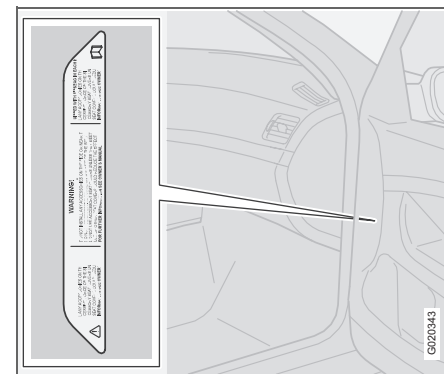

Location of airbag decal in door opening on front passenger side



Inflatable Curtain (IC)

Properties

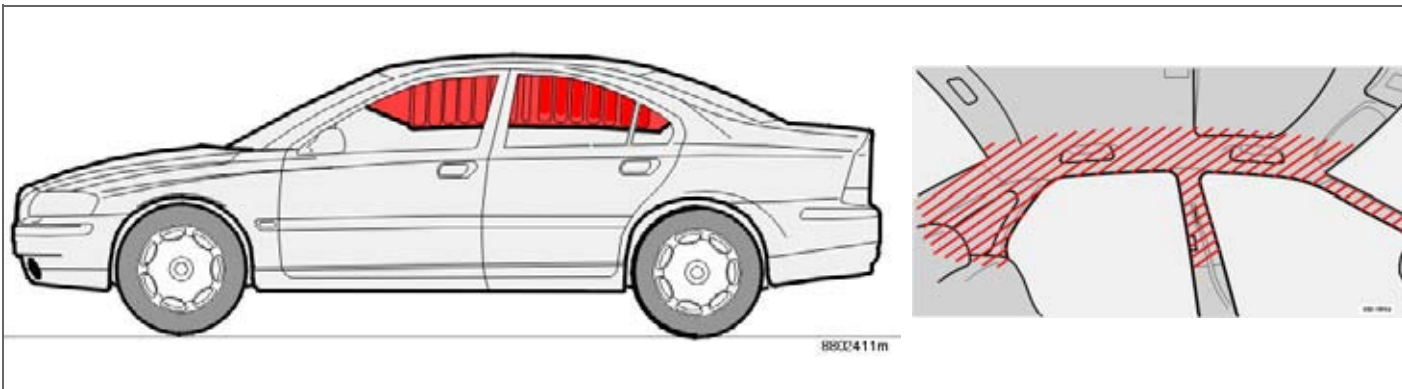

The inflatable curtain IC (Inflatable Curtain) is a supplement to the SIPS and the airbags . It is fitted in the headlining along both sides of the roof and protects all of the vehicle's outer seats. A sufficiently violent collision trips the sensors and the inflatable curtain is inflated. The inflatable curtain helps to prevent the driver and passengers from striking their heads on the inside of the car during a collision.



WARNING

Never hang or fasten anything on the roof handles. The hook is only intended for light outer garments (not for hard objects such as umbrellas).

Do not screw or fit anything to the headlining, door pillars or side panels. This could compromise the intended protection. Only use Volvo genuine parts that are approved for placement in these areas.



WARNING

Do not load the car higher than 50 mm under the top edge of the rear passenger windows. Otherwise, the intended protection of the inflatable curtain, which is hidden in the headlining, may be compromised.



WARNING

The inflatable curtain is a supplement to the seatbelts. Always wear your seatbelt.



Protection against whiplash injury – WHIPS



The whiplash protection system (WHIPS) consists of energy absorbing backrests and specially designed head restraints for the front seats. The system is actuated by a rear-end collision, where the angle and speed of the collision, and the nature of the colliding vehicle all have an influence.

WARNING

The WHIPS system is a supplement to the seatbelts. Always wear your seatbelt.

WARNING

Never modify or repair the seat or WHIPS system yourself. Contact an authorised Volvo workshop.

Properties of the seat

When the WHIPS system is deployed, the front seat backrests fall backward to alter the position of the driver and front seat passenger. This diminishes the risk of whiplash injury.

WHIPS system and child seats/booster cushions

The WHIPS system does not diminish the protection provided by the car to children seated in a child seat or on a booster cushion.

Correct seating position

For the best possible protection, the driver and front seat passenger should sit in the centre of the seat with as little space as possible between the head and the head restraint.



WHIPS

Do not obstruct the WHIPS system



WARNING

Do not squeeze rigid objects between the rear seat cushion and the front seat backrest. Make sure you do not obstruct the function of the WHIPS system.



WARNING

If a rear seat backrest is folded down, the corresponding front seat must be moved forward so that it does not touch the folded backrest.

WARNING

If a seat has been subjected to extreme forces, such as due to a rear-end collision, the WHIPS system must be checked by an authorised Volvo workshop.

Part of the WHIPS system's protective capacity may have been lost even if the seat appears to be undamaged.

Contact an authorised Volvo workshop to have the system checked even after a minor rear-end collision.



When the systems deploy

| System | Triggered |
|---------------------------|--|
| Seatbelt tensioner | In a frontal collision |
| Airbags SRS | In a frontal collision ¹ |
| Side airbags SIPS | In a side-impact accident ¹ |
| Inflatable Curtain IC | In a side-impact accident ¹ |
| Whiplash protection WHIPS | In a rear-end collision |

¹The bodywork of the car could be greatly deformed in a collision without airbag deployment. A number of factors such as the rigidity and weight of the object hit, the speed of the car, the angle of the collision etc. affects how the different safety systems of the car are activated.

If the airbags have been deployed, the following is recommended:

- Have the car transported to an authorised Volvo workshop. Do not drive with deployed airbags.
- Have an authorised Volvo workshop replace components in the car's safety system.
- Always contact a doctor.

**NOTE**

The SRS, SIPS, IC and belt tensioner systems are deployed only once during a collision

**WARNING**

The airbag system control module is located in the centre console. If the centre console is drenched with water or other liquid, disconnect the battery cables. Do not attempt to start the car since the airbags may deploy. Have the car transported to an authorised Volvo workshop.

**WARNING**

Never drive with deployed airbags. They can make steering difficult. Other safety systems may also be damaged. The smoke and dust created when the airbags are deployed can cause skin and eye irritation after intensive exposure. In case of irritation, wash with cold water. The rapid deployment sequence and airbag fabric may cause friction injury and burns to the skin.



Child safety

Children should sit comfortably and safely

The position of a child in the car and the choice of equipment is dictated by the child's weight and size, for more information see page 29.

NOTE

Regulations regarding the placement of children in cars vary from country to country. Check what laws apply.

Children of all ages and sizes must always sit correctly secured in the car. Never allow a child to sit on the knee of a passenger.

Volvo's own child safety equipment is designed for your car. Use Volvo genuine equipment to best ensure that the mounting points and attachments are correctly positioned and are sufficiently strong.

NOTE

If problems arise when fitting child safety products, contact the manufacturer for clearer instructions.

Child seats

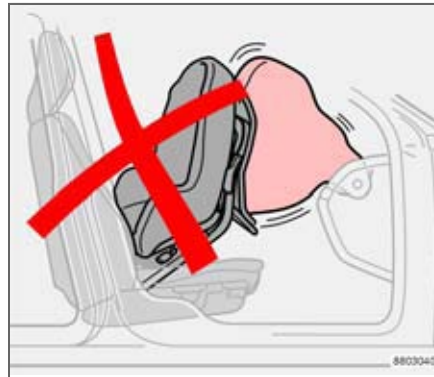

Child seats and airbags are not compatible.

Volvo has child safety products that are designed for and tested by Volvo.

NOTE

When using child safety products it is important to read the installation instructions included with the product.

Do not attach the straps for the child seat to the horizontal adjustment bar, springs, rails or beams under the seat. Sharp edges can damage the straps. Allow the back of the child seat to rest against the instrument

panel. This applies to cars without a passenger airbag, or where the airbag is deactivated.

Location of child seats

You may place:

- a child seat or booster cushion on the front passenger seat, provided the passenger airbag is not activated (for information on activating/deactivating the airbag (SRS), see page 18)
- a rear-facing child seat in the rear seat that uses the back of the front seat as support.

Always place a child in the rear seat if the passenger airbag is activated. A child in a child seat on the front passenger seat may suffer serious injury if the airbag deploys.



WARNING

Never place the child seat in the front seat if the car is equipped with an activated¹ front passenger airbag. If problems arise when fitting child safety products, contact the manufacturer for clearer instructions.

¹ For information on activated/deactivated airbag (SRS) see page 18.

**WARNING**

Booster cushions/child seats with steel braces or some other design that could rest on the seatbelt buckle's opening button must not be used, as they could cause the seatbelt buckle to open accidentally.

Do not allow the upper section of the child seat to rest against the windscreen.



Child safety

Airbag decal



Decal located on instrument panel end face.



*Decal located on instrument panel end face
(Australia only).*



Recommended child seats

| Weight/age | Front seat ¹ | Outer rear seat | Centre rear seat |
|---------------------------------------|---|--|--|
| Group 0 <10 kg (0–9 months) | Volvo Child seat – rear-facing child seat, secured with the car’s seatbelt and straps. | Volvo Child seat – rear-facing child seat, secured with the car’s seatbelt, straps and support legs. | Volvo Child seat – rear-facing child seat, secured with the car’s seatbelt, straps and support legs. |
| | Type approval: E5 03135 | Type approval: E5 03135 | Type approval: E5 03135 |
| | Britax Baby Safe Plus – rear-facing child seat with ISOFIX fixture system. | Britax Baby Safe Plus – rear-facing child seat with ISOFIX fixture system. | Britax Baby Safe Plus – rear-facing child seat secured with the car’s seatbelt. |
| Group 1 9–18 kg (9–36 months) | Type approval: E1 03301146 | Type approval: E1 03301146 | Type approval: E1 03301146 |
| | Volvo Child seat – rear-facing child seat, secured with the car’s seatbelt and straps. | Volvo Child seat – rear-facing child seat, secured with the car’s seatbelt, straps and support legs. | Volvo Child seat – rear-facing child seat, secured with the car’s seatbelt, straps and support legs. |
| | Type approval: E5 03135 | Type approval: E5 03135 | Type approval: E5 03135 |
| Group 2/3 15–36 kg (3–12 years) | Britax Freeway – rear-facing child seat, secured with the ISOFIX fixture system and straps. | Britax Freeway – rear-facing child seat, secured with the ISOFIX fixture system and straps. | |
| | Type approval: E5 03171 | Type approval: E5 03171 | |
| | Volvo Booster cushion – with or without backrest. | Volvo Booster cushion – with or without backrest. | Volvo Booster cushion – with or without backrest. |
| | Type approval: E5 03139 | Type approval: E5 03139 | Type approval: E5 03139 |
| | | | Volvo Integrated booster cushion – available as an option. |
| | | | Type approval: E5 03140 |

¹For information on activated/deactivated airbag (SRS) see page 15.

For other child seats your car should be included in the manufacturer’s enclosed list of vehicles or be universally approved in accordance with the ECE R44 legal requirement.



Child safety

Integrated booster cushions (option)



Volvo's integrated booster cushion for the centre rear seat is specially designed to provide optimum safety for children. Combined with the normal seatbelt, the integrated booster cushion is approved for children weighing between 15 and 36 kg.

Folding out the booster cushion

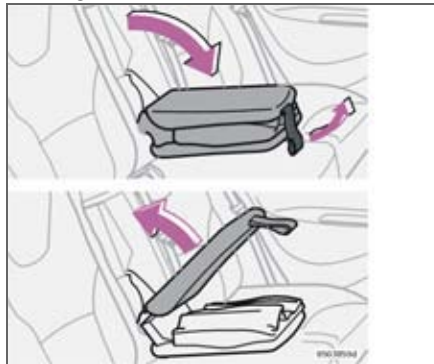

- fold down the booster cushion
- pull apart the Velcro
- raise the upper portion back into place

Check that:

- the seatbelt is in contact with the child's body and is not slack or twisted, and that the seatbelt is positioned correctly across the shoulder.
- the lap belt is low over the pelvis for optimum protection.
- the seatbelt does not lie across the child's throat or below the shoulder.
- Carefully adjust the position of the head restraint to suit the child.



WARNING

Repair or replacement should only be performed by an authorised Volvo workshop. Do not make any modifications or additions to the booster cushion.

If an integrated booster cushion has been subjected to a major load, such as in conjunction with a collision, the entire booster cushion must be replaced. Even if the booster cushion appears to be undamaged, it may not afford the same level of protection. The booster cushion must also be replaced if it is heavily worn.



Folding in the booster cushion

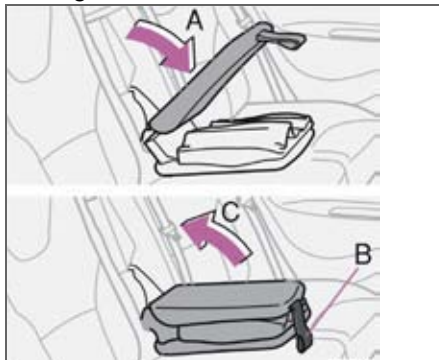

- Fold down the upper section (A).
- Fasten the Velcro (B).
- Raise the booster cushion into the rear seat backrest (C).

NOTE

Make sure that both sections of the booster cushion are secured with the Velcro strap (B) before folding down. Otherwise the upper section (A) could become trapped in the rear seat backrest (C) when the booster cushion is folded out again.



Child safety

ISOFIX fixture system for child seats (option)

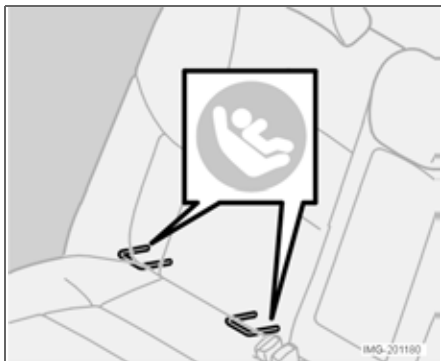

Mounting points for the ISOFIX fixture system are concealed behind the lower section of the rear seat backrest, in the outer seats.

The location of the mounting points is indicated by symbols in the backrest upholstery (see illustration above).

Press the seat cushion down to access the mounting points.

Always follow the manufacturer's installation instructions when connecting a child seat to the ISOFIX mounting points.



[Empty rectangular box]

01

| | |
|--|----|
| Overview, left-hand drive car | 36 |
| Overview, right-hand drive car | 38 |
| Combined instrument panel | 40 |
| Indicator and warning symbols | 42 |
| Information display | 45 |
| Switches in the centre console | 46 |
| Lighting panel | 49 |
| Left-hand stalk switch | 51 |
| Trip computer | 52 |
| Right-hand stalk switch | 53 |
| Cruise control (option) | 55 |
| Steering wheel adjustment, parking brake | 56 |
| Electrical socket, cigarette lighter | 57 |
| Power windows | 58 |
| Rearview and door mirrors | 61 |
| Power sunroof (option) | 65 |

INSTRUMENTS AND CONTROLS



02



02 Instruments and controls

Overview, left-hand drive car

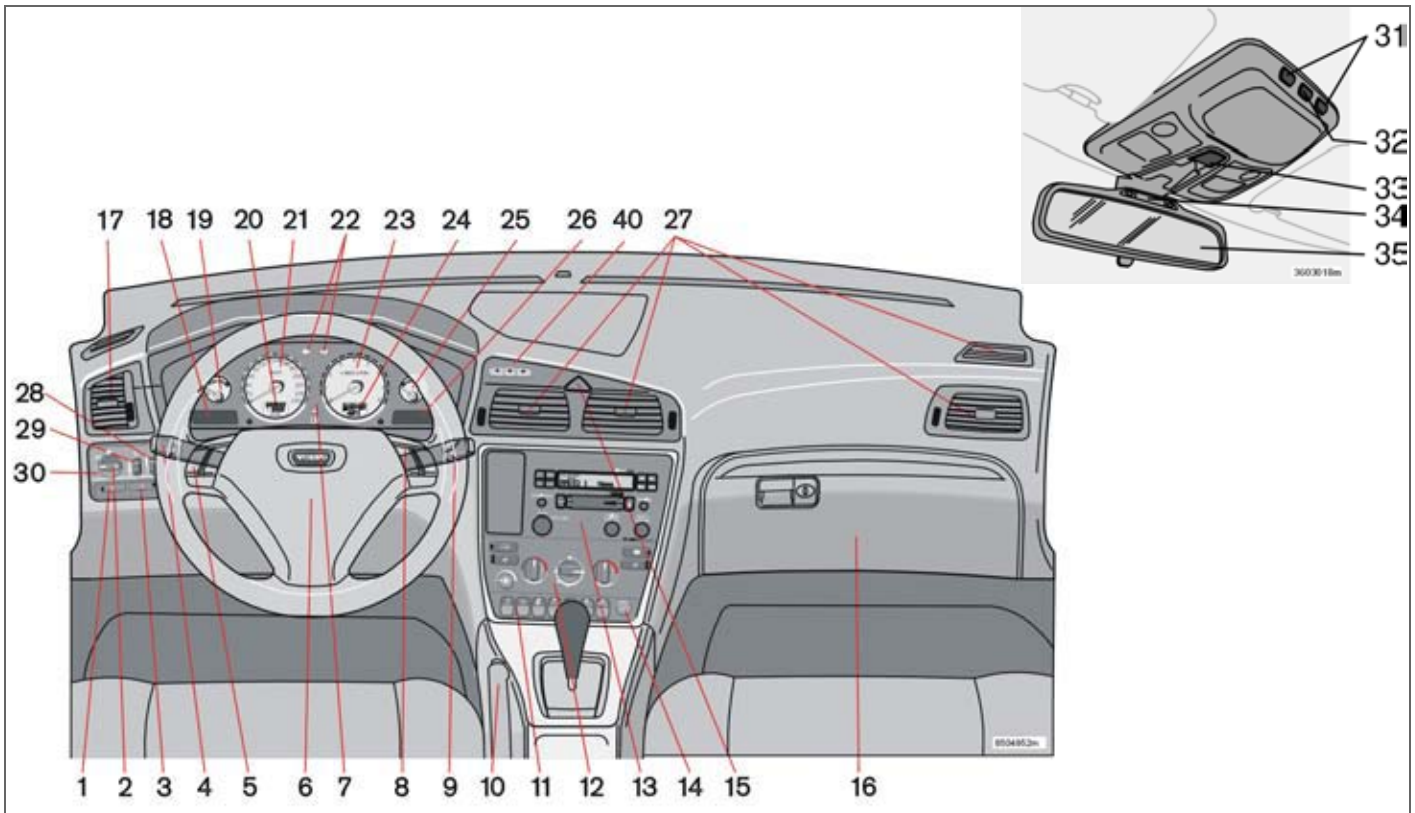



Overview, left-hand drive car

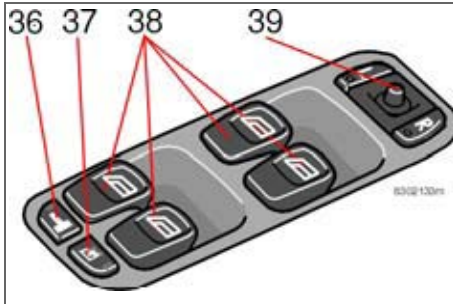

1. Fog lamps
2. Headlamps, position/parking lights
3. Rear fog lamp
4. Direction indicators, beam selection
5. Cruise control
6. Horn
7. Combined instrument panel
8. Keypad for phone/audio
9. Windscreen wipers
10. Parking brake
11. Switch panel
12. Climate control
13. Audio system
14. Electric socket, Cigarette lighter
15. Hazard warning flashers
16. Glovebox
17. Panel vents
18. Display
19. Temperature gauge
20. Odometer, trip meter/cruise control
21. Speedometer
22. Direction indicators
23. Tachometer
24. Outside temperature, clock, gear position
25. Fuel gauge
26. Indicator and warning symbols
27. Panel vents
28. Instrument lighting
29. Headlamp levelling
30. Lighting panel
31. Reading lamps
32. Interior lighting
33. Control, sunroof
34. Seatbelt reminder
35. Rearview mirror
36. Lock button, for all doors
37. Blocking power windows in the rear doors
38. Controls, power windows
39. Controls, power door mirrors
40. Active chassis FOUR-C



02 Instruments and controls

Overview, right-hand drive car

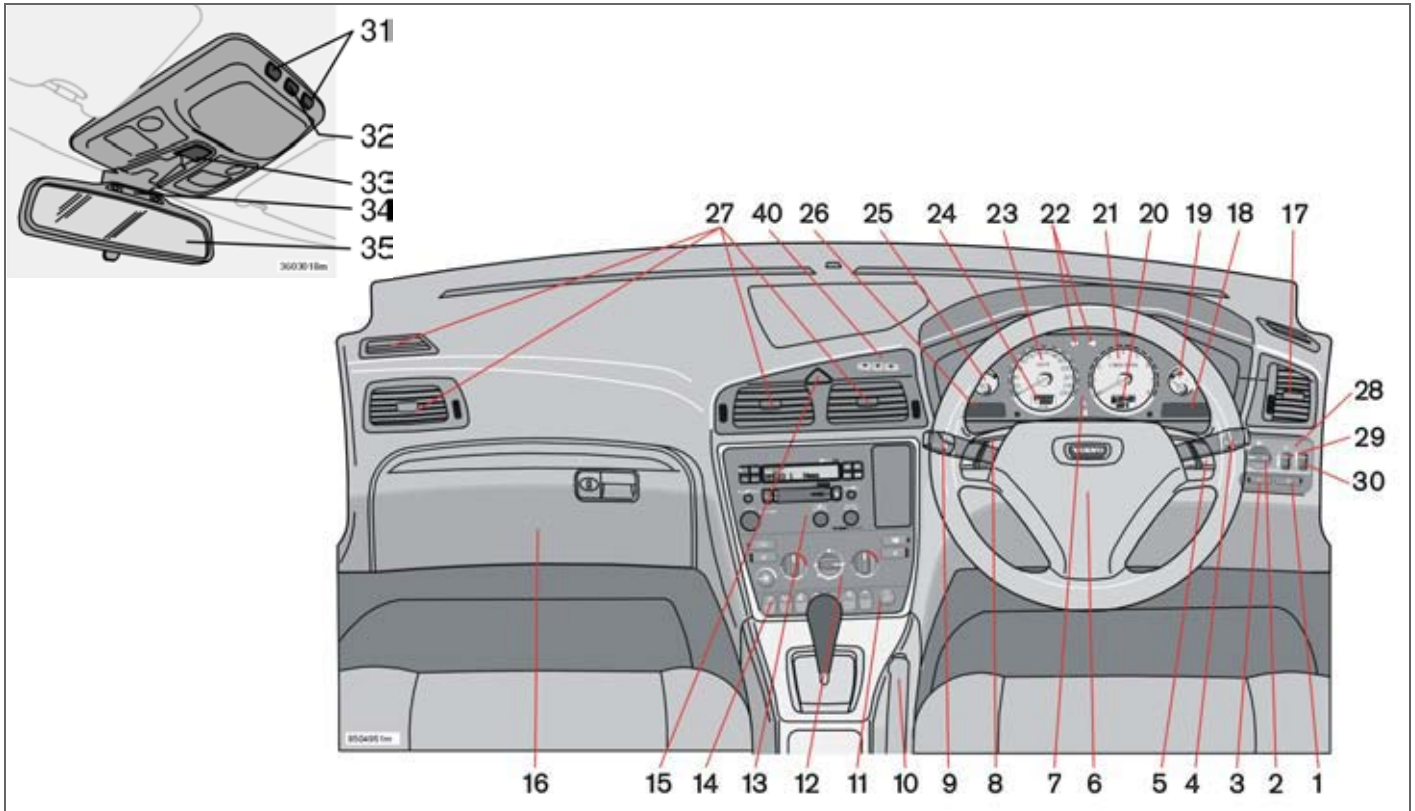



Overview, right-hand drive car

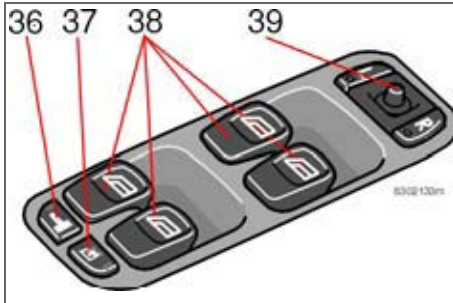

Driver's door control panel

1. Rear fog lamp
2. Headlamps, position/parking lights
3. Fog lamps
4. Windscreen wipers
5. Keypad for phone/audio
6. Horn
7. Combined instrument panel
8. Cruise control
9. Direction indicators, beam selection
10. Parking brake
11. Electric socket, Cigarette lighter
12. Climate control
13. Audio system
14. Switch panel
15. Hazard warning flashers
16. Glovebox
17. Panel vents
18. Indicator and warning symbols
19. Fuel gauge
20. Outside temperature, clock, gear position
21. Tachometer
22. Direction indicators
23. Speedometer
24. Odometer, trip meter/cruise control
25. Temperature gauge
26. Display
27. Panel vents
28. Lighting panel
29. Headlamp levelling
30. Instrument lighting
31. Reading lamps
32. Interior lighting
33. Control, sunroof
34. Seatbelt reminder
35. Rearview mirror
36. Lock button, for all doors
37. Blocking power windows in the rear doors
38. Controls, power windows
39. Controls, power door mirrors
40. Active chassis FOUR-C

Combined instrument panel

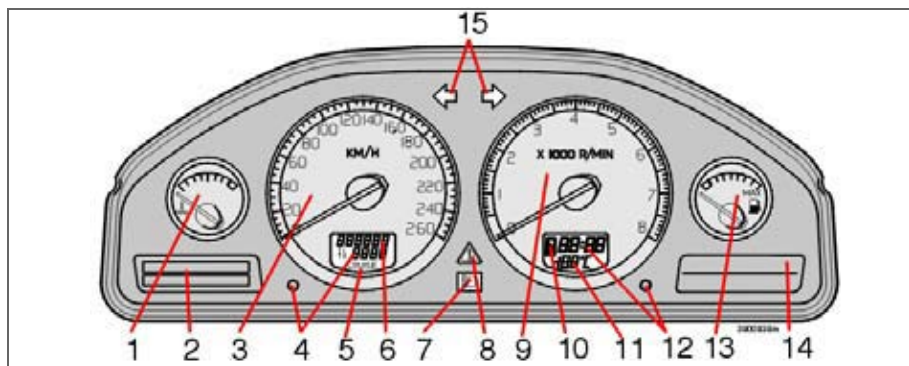

1. Temperature gauge

Displays the temperature of the engine cooling system. If the temperature is abnormally high and the needle enters the red zone, a message is shown in the display. Bear in mind that extra lamps in front of the radiator grille reduce the cooling capacity at high outside temperature and high engine loads.

2. Display

Information and warning messages are shown in the display.

3. Speedometer

Shows the speed of the car.

4. Trip meter, T1 and T2

The trip meters are used for measuring short distances. The right-hand digit displays tenths of a kilometre. Press the button for more than 2 seconds to reset. Switch between trip meters with one quick press of the button.

5. Cruise control indicator

See page 55.

6. Trip meter

The odometer indicates the total distance the car has travelled.

7. Main beam indicator

8. Warning symbol

If a fault arises, the symbol illuminates and a message is shown in the display.

9. Tachometer

Indicates engine speed in thousands of revolutions per minute (RPM). Do not allow the needle of the tachometer to enter the red field.

10. Automatic gearbox indicator

The selected gearshift programme is displayed here. If you have Geartronic auto-

**Combined instrument panel**

matic gearbox and drive using the manual function, the current manual gear is displayed.

11. Outside temperature gauge

Displays outside temperature. When the temperature lies between +2 °C to -5 °C, a snowflake symbol is shown in the display. This symbol serves as a warning for slippery road surfaces. When the car is or was stationary, the outside temperature gauge may display a higher reading than the actual temperature.

12. Clock

Turn the button to set the clock.

13. Fuel gauge

When the lamp in the instrument panel lights, approximately 8 litres of usable fuel remain in the tank.

14. Indicator and warning symbols**15. Direction indicators – left/right.**

Indicator and warning symbols

Indicator and warning symbols

All indicator and warning symbols¹ illuminate when the ignition key is turned to position II before starting. This is to check that the symbols are working. When the engine starts, all the symbols should go out except the handbrake symbol, which extinguishes when the handbrake is released.



If the engine does not start within five seconds, all symbols extinguish except the symbols for a fault in the car's emissions system and for low oil pressure. Certain symbols may have no function, depending on the car's specifications.

Warning symbols in the centre of the instrument panel

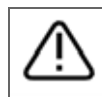
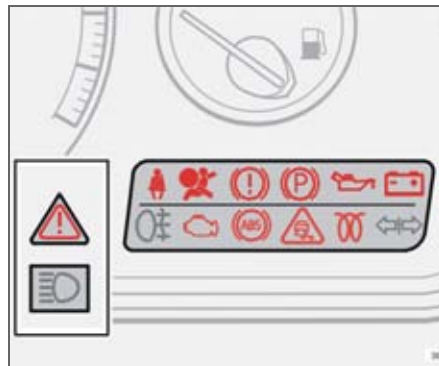

These symbols illuminate with a red or amber glow depending on the severity of the fault.

Red symbol

- Stop the car in a safe place. Do not drive the car further.
- Read the information on the display.
- Rectify the fault as instructed or contact an authorised Volvo workshop.

Symbol and message text are visible until the fault has been rectified.

Yellow symbol

- Read the message on the display.
- Action.

The message text is cleared using the **READ** button, see page 45, or disappears automatically after 2 minutes.

When the message text **TIME FOR REGULAR SERVICE** is shown, the symbol lamp and message text are cleared using the **READ** button, or disappear automatically after 2 minutes.

ABS fault



If this symbol illuminates, the system is not working. The car's regular brake system continues to work, but without the ABS function.

- Stop the car in a safe place and turn off the engine.
- Restart the engine.

If the warning symbol remains illuminated, drive to an authorised Volvo workshop to have the ABS system checked.

Fault in brake system



If this symbol illuminates, the brake fluid level may be too low.

¹ For certain engine variants, the symbol for low oil pressure is not used. Warnings are given via display text, see page 186.



Indicator and warning symbols

- Stop the car in a safe place and check the brake fluid reservoir level.

If the reservoir level is below **MIN**, the car should not be driven further. Have it towed to an authorised Volvo workshop to have the brake system checked.



If the warning symbols for BRAKE and ABS illuminate at the same time, there may be a fault in the brake force distribution system.

– Stop the car in a safe place and switch off the engine. Restart the engine.

- If both symbols go out, it was an indicator error.
- If the warning symbols remain illuminated, check the level in the brake fluid reservoir. See page 189.
- If the reservoir level is below **MIN**, the car should not be driven further. Have it towed to an authorised Volvo workshop to have the brake system checked.
- If the brake fluid level is normal and the symbols remain illuminated, drive the car carefully to the nearest authorised Volvo workshop to have the brake system checked.



WARNING

If the warning symbols for BRAKE and ABS illuminate at the same time, there is a risk that the rear of the car will have a tendency to slide during heavy braking.

Seatbelt reminder



This symbol illuminates until the driver buckles up.

Low oil pressure¹



If this symbol illuminates during driving then the engine's oil pressure is too low. Stop the engine immediately and check the engine oil level. If the symbol illuminates and the oil level is normal, contact an authorised Volvo workshop.

Fault in car's emissions system



Drive to an authorised Volvo workshop to have the system checked.

¹ For certain engine variants, the symbol for low oil pressure is not used. Warnings are given via display text, see page 186.

Fault in SRS



If this symbol remains on or illuminates while driving, it means a fault has been detected in the SRS system (airbags). Drive to an authorised Volvo workshop to have the system checked.

Alternator not charging

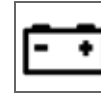

If this symbol illuminates while driving, there is probably a fault in the electrical system. Contact an authorised Volvo workshop.

Engine preheater (diesel)

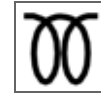

This symbol indicates engine preheating. You can start the car when the symbol switches off. Applies to diesel cars only.

Parking brake applied



The symbol illuminates when the parking brake is applied. Always pull the parking brake lever to the end position.



NOTE

The symbol illuminates irrespective of how hard the parking brake is applied.



Indicator and warning symbols

Rear fog lamp

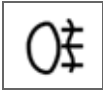

This symbol is illuminated when the fog lamp is on.

Trailer indicator lamp



Flashes when the direction indicators of the car and trailer are used. If the symbol does not flash, one of the direction indicator lamps on the trailer or car is defective.

Stability systems STC/DSTC



The system's different functions and symbols are described on page 124.

02



Information display

Messages in the display

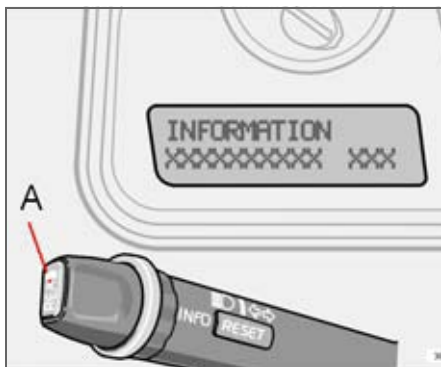

A message appears in the display whenever a warning or indicator symbol illuminates. Once you have read and understood the message, press the **READ** button (A). Read messages are then erased from the display and stored in a memory. Messages regarding faults remain in the memory until the fault has been remedied.

Very serious fault messages cannot be erased from the display. They remain in the display until the fault is remedied.

Messages stored in the memory can be read again. Press the **READ** button (A) to see stored messages. Scroll through the messages stored in the memory by pressing the **READ** button.

Press the **READ** button to return read messages to the memory.

NOTE

If a warning message interrupts when you are in the trip computer menu or wish to use the phone, you must first acknowledge the message by pressing the **READ** button (A).

| Message | Specification |
|-------------------------------|---|
| STOP SAFELY | Stop the car in a safe manner and turn off the engine. Serious risk of damage. |
| STOP ENGINE | Stop the car in a safe manner and turn off the engine. Serious risk of damage. |
| SERVICE URGENT | Have the car checked by an authorised Volvo workshop immediately. |
| SEE MANUAL | Read the owner's manual. |
| SERVICE REQUIRED | Have the car checked by an authorised Volvo workshop as soon as possible. |
| FIX NEXT SERVICE | Have your car checked at the next service interval. |
| TIME FOR REGULAR SERVICE | Time for regular service at an authorised Volvo workshop. The timing is determined by the number of kilometres driven, number of months since the last service and engine running time. |
| SOOT FILTER FULL – SEE MANUAL | Diesel particle filter requires regeneration, see page 114. |
| STC/DSTC SPIN CONTROL OFF | The function of the stability and traction control system is reduced, see page 124 for more variants. |



Switches in the centre console

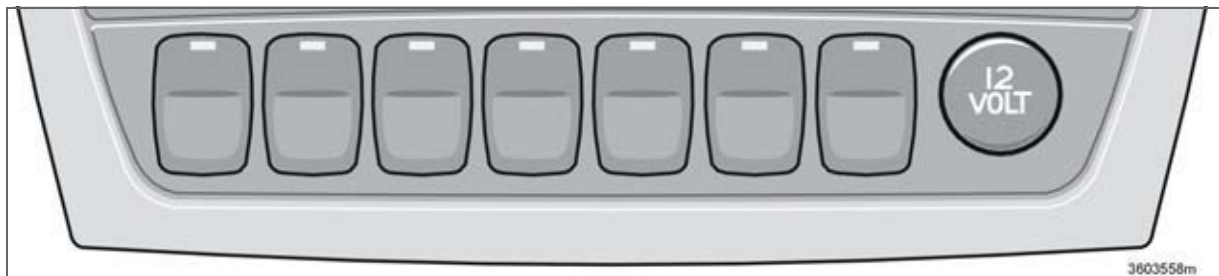

NOTE

The order of the buttons may vary.

Active chassis, **FOUR-C (option)**



Press the button to select the Comfort or Sport chassis setting, see page 126. The display shows the current setting for 10 seconds.

BLIS (Blind Spot Information System) – option



Press the button to deactivate or reactivate the function. For further information, see page 149.

DSTC system



This button is used to reduce or reactivate the functions of the DSTC system.

When the lamp in the button is illuminated, the DSTC

system is activated (assuming there is no fault).

Hold the button depressed for at least half a second to reduce the function of the DSTC system. The lamp in the button goes out and the text **DSTC ANTI-SKID OFF** is shown in the display.

The DSTC system is reactivated when the engine is restarted. For more information, see page 149.

WARNING

Keep in mind that car's driving characteristics may change if you deactivate the DSTC system.

Electric socket/Cigarette lighter (option)



The electric socket can be used for various 12 V accessories, e. g. mobile phone or a cooler box.

The ignition key must be at least in position **I** so that the socket can supply power.

The cigarette lighter is activated by pressing in the button. Once the lighter has been



Switches in the centre console

heated, the button pops out again. Pull out the lighter to use it. For safety reasons, always keep the cover in place when the socket is not in use. Maximum current tap 10 A.

Lowering the outer head restraints in the rear seat (option)



Do not lower the head restraints if there is a passenger in one of the outer seats.

- Turn the ignition key to position **I** or **II**.
- Press the button to tilt the rear head restraints forward for a better rear view.

The head restraints are moved back manually.

The head restraints must be in their upright positions if the rear backrests are to be folded down.

Retractable power door mirrors (option)



This button is used to fold in the door mirrors if they are folded out or to fold them out if they are folded in.

Proceed as follows if a door mirror has been accidentally folded in or out:

- Manually fold the door mirror forward as far as possible.
- Turn the ignition key to position **II**.
- Fold the door mirror inward and then outward using the button.

The door mirrors have now returned to their original fixed positions.

Parking assistance (option)



The system is always activated when the car is started. Press the button to deactivate/reactivate parking assistance. See also page 127.

Locking the boot lid (certain countries)



Press this button in order to lock the boot lid. The boot lid remains locked even if the doors are unlocked manually with the master key, the master key remote control or the service key.

Deactivation of the deadlocks and detectors



Use this button if you wish to switch off the deadlock function (doors cannot be opened from the inside when locked). This button can also be used when deactivating the alarm system's movement and tilt detectors¹ – e.g. when transporting the car by ferry. The lamp illuminates when the functions are deactivated.

Auxiliary lamps (accessory)



Use this button if you want the auxiliary lamps of the car to come on together with the main beam or to deactivate this function. The lamp in the button is illuminated when the function is active.

¹ Option

Switches in the centre console

Active Bi-Xenon Lights, ABL (option)



The ABL headlamps' headlamp pattern follows the movements of the steering wheel during driving. The function is activated automatically when the car is started and can be deactivated/activated by pressing the button. The lamp in the button illuminates when the function is activated.

Shifting headlamp pattern for right/left-hand traffic

Hold the button depressed for at least five seconds. The car must be stationary when the headlamp pattern is shifted.

The message **DIPPED BEAM SETT. F. RIGHT TRAFFIC** or **DIPPED BEAM SETT. F. LEFT TRAFFIC** is shown in the display. For more information and adapting headlamp pattern for halogen or Bi-Xenon headlamps, see page 143.

Hazard warning flashers

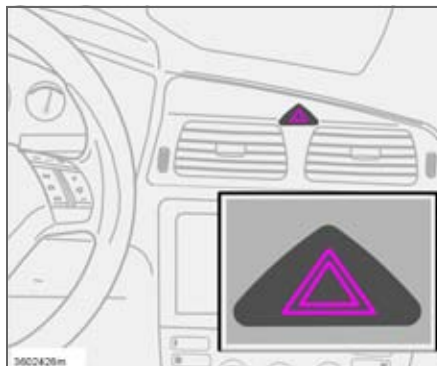

Use the hazard warning flashers (all direction indicators flash) when the car is stopped where it could be a traffic hazard or obstruction. Press the button to activate the function.

NOTE

Regulations regarding the use of hazard warning flashers vary from country to country.

Door mirror and rear window defrosters



Heating is used to quickly remove misting and ice from the rear window and door mirrors.

Press the switch to start defrosting the rear window and door mirrors. The lamp in the switch illuminates.

Defrosting is automatically disconnected after about 12 minutes.

Heated front seats



See page 73 or page 75 for further information.



Lighting panel

Headlamps

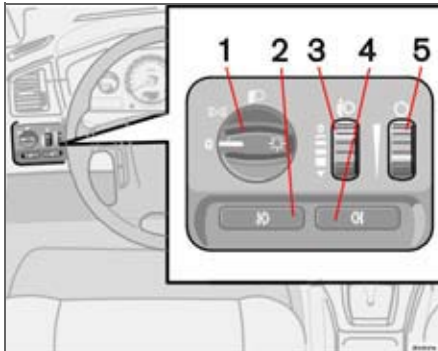

| Position | Specification |
|----------|---|
| 0 | Automatic/deactivated dipped beam. Only main beam flash. |
| | Position/parking lamps |
| | Automatic dipped beam. Main beam and main beam flash work in this position. |



Automatic dipped beam (certain countries)

Dipped beam comes on automatically when the ignition key is turned to position **II**, except when the headlamp control (1) is in the centre position. If necessary the auto-

matic dipped beam can be deactivated by an authorised Volvo workshop.

Automatic dipped beam, main beam

- Turn the ignition key to position **II**.
- Dipped beam is activated by means of turning the headlamp control (1) clockwise to the end position.
- Main beam is activated by means of moving the left-hand stalk switch towards the steering wheel to the end position and releasing it, see page 51.

The lamps are switched off automatically when the ignition key is turned to position **I** or **0**.

Position/parking lamps

Position/parking lamps can be switched on irrespective of ignition key position.

- Turn the headlamp control (1) to the centre position.

When the ignition key is in position **II** the position/parking lamps and number plate lighting are always on.

Headlamp levelling

The load in the car changes the vertical alignment of the headlamp beam, which could dazzle oncoming motorists. Avoid this by adjusting the height of the beam.

- Turn the ignition key to position **II**.
- Turn the headlamp control (1) to one of the end positions.
- Roll the control (3) up or down respectively to raise or lower beam alignment.

Cars with Active Bi-Xenon and Bi-Xenon headlamps¹ have automatic headlamp levelling, so there is no control (3).

Instrument lighting

The instrument lighting is switched on when the ignition key is in position **II** and the headlamp control (1) is in one of the end positions. The lighting is automatically dimmed during the day and can be controlled manually at night.

- Roll the control up or down (5) for brighter or dimmer lighting.

¹ Option.



Lighting panel

Fog lamp

i NOTE

Regulations for use of fog lamps vary from country to country.

2 – Front fog lamps (option)

The front fog lamps can be switched on along with the headlamps or the position lamps/parking lamps.

- Press the button (2).

The light in the button (2) illuminates when the front fog lamps are switched on.

4 – Rear fog lamp

The rear fog lamp can only be switched on with the headlamps or the front fog lamps.

- Press the button (4).

The rear fog lamp indicator symbol on the combined instrument panel and the light in the button (4) illuminate when the rear fog lamp is switched on.

Active Bi-Xenon Lights, ABL (option)

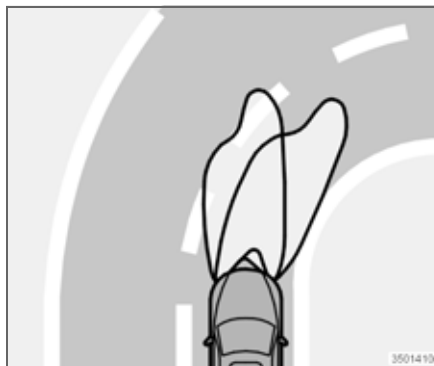

The ABL headlamps' headlamp pattern follows the movements of the steering wheel during driving. The function is activated automatically when the car is started and can be deactivated/activated using the button in the centre console, see page 48.



Left-hand stalk switch

Stalk switch positions

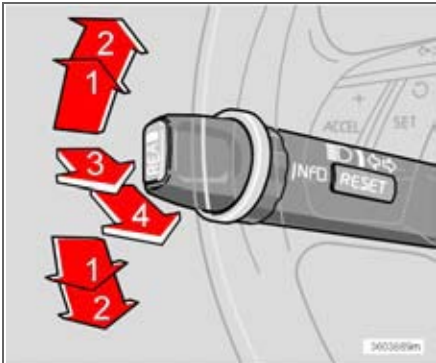

1. Short flash sequence, direction indicators
2. Continuous flash sequence, direction indicators
3. Main beam flash
4. Switching, main and dipped beam, and home safe lighting

Direction indicators

Continuous flash sequence

- Move the stalk switch up or down to end position (2).

The stalk switch remains in its end position and is moved back manually, or automatically by steering wheel movement.

Short flash sequence

- Move the stalk switch up or down to position (1) and release, the stalk switch then returns to its home position, or move the stalk switch to position (2) and move it directly back to the home position.

The direction indicators flash three times.

Short flash sequence interrupted immediately if indicating is started in the opposite direction.

Switching, main and dipped beam

The ignition key must be in position **II** for main beam to be switched on.

- Turn the headlamp control clockwise to the end position, see page 49.
- Move the stalk switch towards the steering wheel to the end position (4) and release.

Main beam flash

- Move the stalk switch gently towards the steering wheel to position (3).
Main beam comes on until the stalk switch is released.

Home safe lighting

Some exterior lights can be kept lit and serve as home safe lighting after the car has been locked. The standard delay is 30 seconds¹, but can be changed to 60 or 90 seconds.

- Remove the key from the ignition switch.
- Move the stalk switch towards the steering wheel to the end position (4) and release.
- Get out of the car and lock the door.

¹ Factory settings.



Trip computer

Trip computer (option)

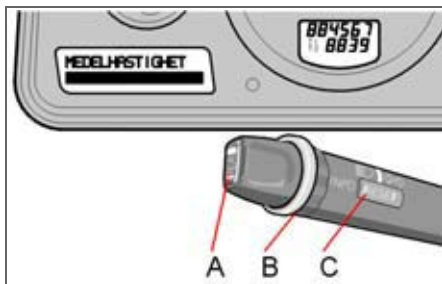

Controls

To scroll through trip computer information, turn the thumbwheel (B) in steps, either upward or downward. Continue turning to return to the starting point.

i NOTE

If a warning message interrupts while you are using the trip computer, this message must be acknowledged. Acknowledge by pressing the **READ** button (A) and revert to the trip computer function.

Functions

The trip computer displays the following information:

- **AVERAGE SPEED**

- **SPEED IN MILES PER HOUR¹**
- **INSTANTANEOUS**
- **AVERAGE**
- **KILOMETRES TO EMPTY TANK**
- **STC/DSTC**, see page 124

Average speed

The average speed since the last reset (RESET). When the ignition is switched off, the average speed is stored and used as the basis of the new value when you continue driving. This can be reset with the RESET button (C) on the stalk switch.

Speed in miles per hour¹

Current speed is displayed in mph if the speedometer is graduated in km/h. If it is graduated in mph then the current speed is shown in mph.

Instantaneous

Continuous information on current fuel consumption, calculated each second. The figure in the display is updated every couple of seconds. When the car is stationary, "----" is shown in the display.

¹ Certain countries.

i NOTE

There may be a slight error in the reading if a fuel-driven heater is used.

Average

The average fuel consumption since the last reset. Reset using RESET.

i NOTE

There may be a slight error in the reading if a fuel-driven parking heater (option/accessory) has been used.

Kilometres to empty tank

The calculation is based on the average fuel consumption over the last 30 km and the remaining driveable fuel quantity. The display shows the approximate distance that can be driven with the fuel quantity remaining in the tank. When fuel for less than 20 km remains then the display shows "----".

i NOTE

There may be a slight error in the reading if a fuel-driven parking heater (option/accessory) has been used or if driving style has been changed.



Right-hand stalk switch

Windscreen wipers

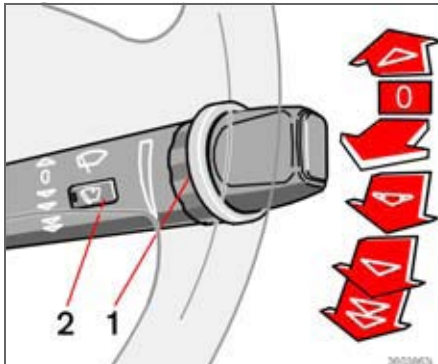

Windscreen wipers off

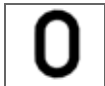

The windscreen wipers are off when the stalk switch is in position **0**.

Single sweep



Raise the stalk switch to make a single sweep.

Intermittent wiping



You can set a suitable delay between the sweeps. Turn the thumbwheel (1) up for a shorter interval between sweeps. Turn it down to increase the delay.

Continuous wiping

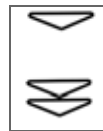

The wipers sweep at normal speed.

The wipers sweep at high speed.

! IMPORTANT

Use plenty of washer fluid when the wipers are cleaning the windscreen. The windscreen must be wet when the windscreen wipers are operating.

Rain sensor (option)

The rain sensor automatically activates the windscreen wipers based on how much water it detects on the windscreen. The sensitivity of the rain sensor can be adjusted using the thumbwheel (1).

Turn the thumbwheel upwards for higher sensitivity and downwards for lower sensitivity. (An extra sweep is made when the thumbwheel is turned upwards.)

On/Off

When activating the rain sensor, the ignition key must be in position **I** or **II** and the windscreen wiper stalk switch must be in position **0** (not activated).

To activate the rain sensor:

- press the button (2). A lamp in the button illuminates to indicate that the rain sensor is active.

To turn the rain sensor off, either:

- press the button (2) or
- press the stalk switch downward to another wiper programme.



If the stalk switch is raised, the rain sensor will remain active, the wipers make an extra sweep and

then return to rain sensor mode when the stalk is released to position **0**.

The rain sensor is automatically deactivated when the key is removed from the ignition switch or five minutes after the ignition is switched off.

! IMPORTANT

In an automatic car wash:

Turn off the rain sensor by pressing the button (2) while the ignition key is in position **I** or **II**. Otherwise, the windscreen wipers may start and be damaged.



Right-hand stalk switch

Windscreen washer

Pull the stalk switch towards the steering wheel to start the windscreen washers. The wipers will make several more sweeps once the stalk switch is released.

Headlamp washers (option certain markets)

Use of the windscreen washer automatically activates the headlamp washer.

High-pressure headlamp washing consumes a large quantity of washer fluid. To save fluid, the headlamps are only washed every fifth wash cycle (within a ten minute period).

When ten minutes have elapsed following the latest windscreen washing, the headlamps are again washed with high-pressure with the first windscreen washing. Turn the stalk switch toward the steering wheel to wash the windscreen only.

Reduced washing

If only approx. one litre of washer fluid remains in the reservoir, the supply to the headlamps is cut off in order to prioritise cleaning of the windscreen.



Cruise control (option)

Activating

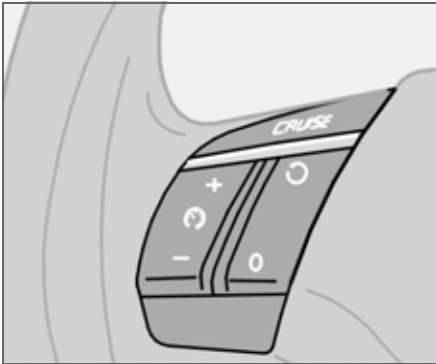

The controls for cruise control are to the left of the steering wheel.

- Setting the desired speed:
- Press the **CRUISE** button. **CRUISE** is shown on the combined instrument panel.
- Touch + or – to lock the vehicle speed. **CRUISE-ON** appears on the combined instrument panel.

Cruise control cannot be engaged at speeds below 30 km/h or above 200 km/h.

Increasing or decreasing speed

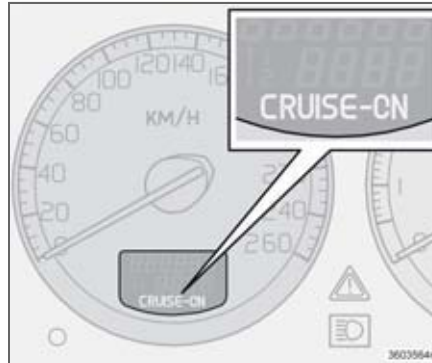

- Increase or decrease the speed by pressing and holding + or –. The speed of the car when the button is released is set as the new speed.

A brief press (less than half a second) on + or – changes the speed by 1 km/h.

i NOTE

A temporary increase in speed (less than one minute) using the accelerator, such as while overtaking, does not affect the cruise control setting. When you release the accelerator, the car will return to the programmed speed.

Temporary disengagement

Press **0** to disengage the cruise control temporarily. **CRUISE** will be shown on the combined instrument panel. The speed set earlier is stored in the memory.

The cruise control is also temporarily disengaged when:

- the brake pedal or clutch pedal is depressed
- speed falls below 25–30 km/h when travelling uphill¹
- the gear selector is moved to position **N**
- wheel spin or wheel lock-up occurs.
- a temporary increase in speed lasts longer than one minute.

Return to the set speed



Press this button to resume the previously set speed. **CRUISE-ON** appears on the combined instrument panel.

Disengaging

Press **CRUISE** to disengage the cruise control. **CRUISE-ON** goes out on the combined instrument panel.

¹ Depending on engine type

Steering wheel adjustment, parking brake

Steering wheel adjustment

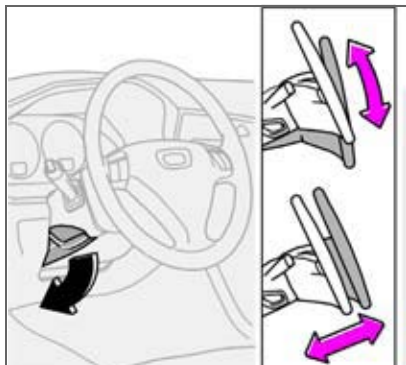

The steering wheel can be adjusted for both height and reach.

- Press down the control on the left-hand side of the steering column.
- Then adjust the steering wheel to the position that suits you best.
- Press the control back into place to lock the steering wheel. If this is difficult, press the steering wheel slightly while pressing the control back.

WARNING

Adjust the steering wheel before driving off, never while driving. Before driving, check that the steering wheel is fixed in position.

Parking brake (handbrake)

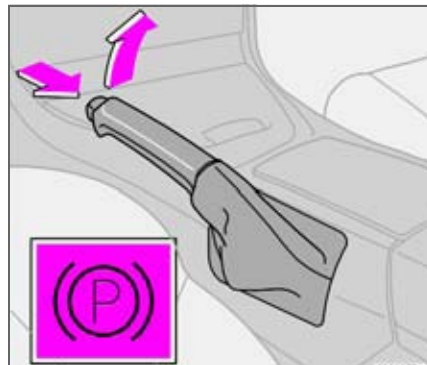

The lever is located between the front seats.

NOTE

The warning lamp symbol in the combined instrument panel comes on irrespective of how hard the parking brake is applied.

How to apply the parking brake

- Press the foot brake down firmly.
- Pull up the parking brake lever up firmly to its full extent.
- Release the foot brake and make sure that the car is stationary.
- If the vehicle rolls, the parking brake lever must be pulled more firmly.

- When parking a vehicle always put the gear selector in position **1** (for manual transmission) or **P** (for automatic transmission).

Parking on a hill

If the car is parked facing uphill; turn the wheels away from the kerb.

If the car is parked facing downhill, turn the wheels towards the kerb.

How to release the parking brake

- Press the foot brake down firmly.
- Pull the parking brake lever up slightly, press the button, release the parking brake lever and release the button.

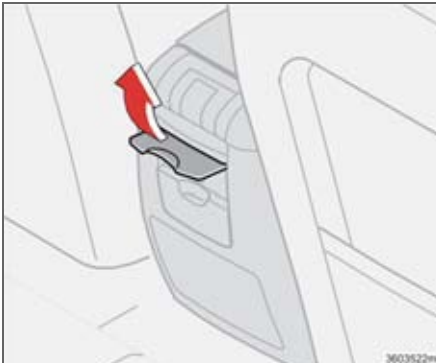
**Electrical socket, cigarette lighter****Electrical socket in rear seat**

The electrical socket can be used for accessories, such as a mobile phone charger or a cooler, and it is designed for 12 V. The maximum current is 10 A.

The ignition key must be at least in position I for the socket to supply power.

**WARNING**

For reasons of safety, always keep the cover in place when the socket is not in use.

Cigarette lighter (option)

- Press in the lighter to activate it.

The button pops out when the lighter is hot. Pull out the lighter and light a cigarette on the heated coils.

Power windows

Operating

The power windows are operated using the controls in the doors. The ignition key must be in position **I** and **II** for the power windows to operate. The windows continue to work when the car is stopped and ignition key removed, provided none of the doors is opened. Operate the windows with caution.

To open a window:

- Depress the front of the control.

To close a window:

- Raise the front of the control.

WARNING

Make sure that children and other passengers cannot be trapped in any way when closing the windows. Pay close attention if the rear door windows are controlled from the driver's door or if the windows are closed with the remote control.

Driver's door

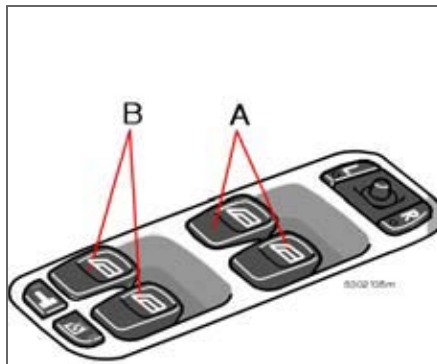

Controls, power windows. A. Front B. Rear.

The driver can operate all power windows from the driver's seat.

The windows can be opened and closed in two ways:

Manual operation

- Depress one of the controls (A) or (B) gently or raise it gently. The power window opens or closes as long as the switch is actuated.

Automatic operation

- Fully depress one of the controls (A) or (B) or raise it fully, then release. The side

window will then open or close automatically. If the window is obstructed by an object, the movement will stop.

WARNING

The function that interrupts the movement of the windows in the event of blocking works only with automatic closing, not with manual.

WARNING

If there are children in the car:

Remember to switch off the supply to the power windows by removing the ignition key if the driver leaves the car.

Make sure that children and other passengers cannot be trapped in any way when closing the windows.



Power windows

Blocking power windows in the rear doors

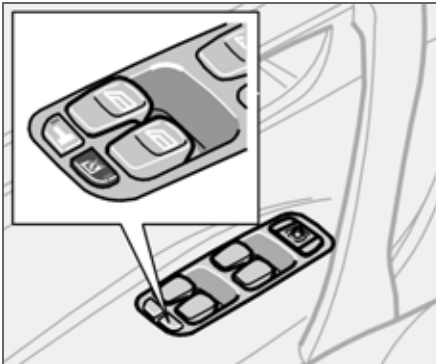

Blocking rear power windows and electric child safety locks¹.

The rear power windows can be blocked using the switch on the driver's door control panel.

The light in the switch is illuminated

The rear door windows can only be operated from the driver's door.

The light in the switch is extinguished

The rear door windows can be operated both with the controls on each rear door and with the controls on the driver's door.

NOTE

If the car has electric child safety locks on the rear doors, the light indicates that these are also activated. The doors then cannot be opened from the inside. A text message is shown on the display when the electric child safety locks are activated.

Front passenger seat



Front passenger seat

The control in the front passenger door operates that window only.

¹ Option.



Power windows

Rear power windows

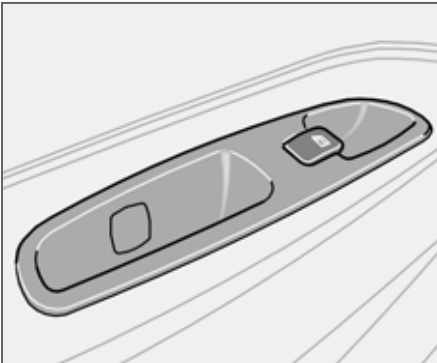

The rear door windows can be operated with the control on each rear door or with the switch on the driver's door.

If the light in the switch for blocking the rear power windows (located in the control panel in the driver's door) is lit, the rear door windows can only be operated from the driver's door.

The windows in the rear doors are operated in the same way as the windows in the front doors.

02



Rearview and door mirrors

Interior rearview mirror

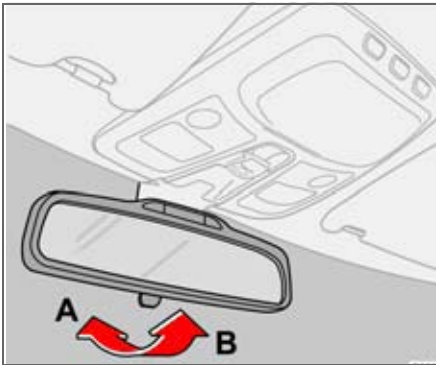

Bright light from behind could be reflected in the rearview mirror and dazzle the driver. Use dimming when disturbed by light from behind.

Dimming

- A. Normal position
- B. Dimmed position.

Automatic dimming (option)

Bright light from behind is automatically dimmed by the rearview mirror.

i NOTE

The control is not available on mirrors with automatic dimming.

Rearview mirror with compass (option in certain markets)

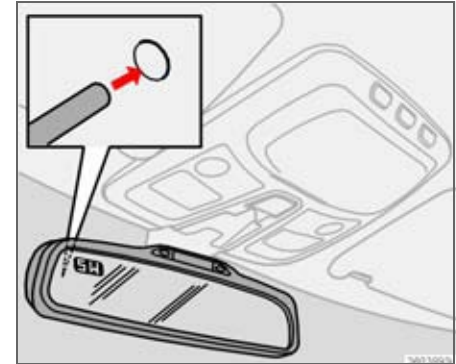

The upper left-hand corner of the rearview mirror has an integrated display that shows the compass direction in which the front of the car is pointing.

Eight different directions are shown with English abbreviations: **N** (north), **NE** (north east), **E** (east), **SE** (south east), **S** (south), **SW** (south west), **W** (west) and **NW** (north west).

If the compass is activated then it starts automatically in ignition position **II** or when the engine is running.



Rearview and door mirrors

Switch the compass on or off by pressing the button set into the rear of the mirror. Use a straightened paper clip for example. The button is countersunk approximately 2.5 cm in the mirror.

Set the correct zone for the compass

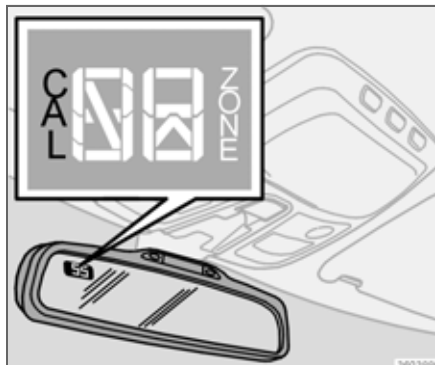

The earth is divided into 15 magnetic zones. The correct zone must be selected for the compass to function correctly.

- Ignition position **II**.
- Press and hold the button on the rear of the mirror for approximately 3 seconds until **ZONE** is shown (use a straightened paper clip for example). The number for the current area is shown.
- Press the button several times until the number for the required geographic area (1 –15) is shown. After several seconds the display returns to show the compass direction, this means that the change of zone is complete.



Rearview and door mirrors

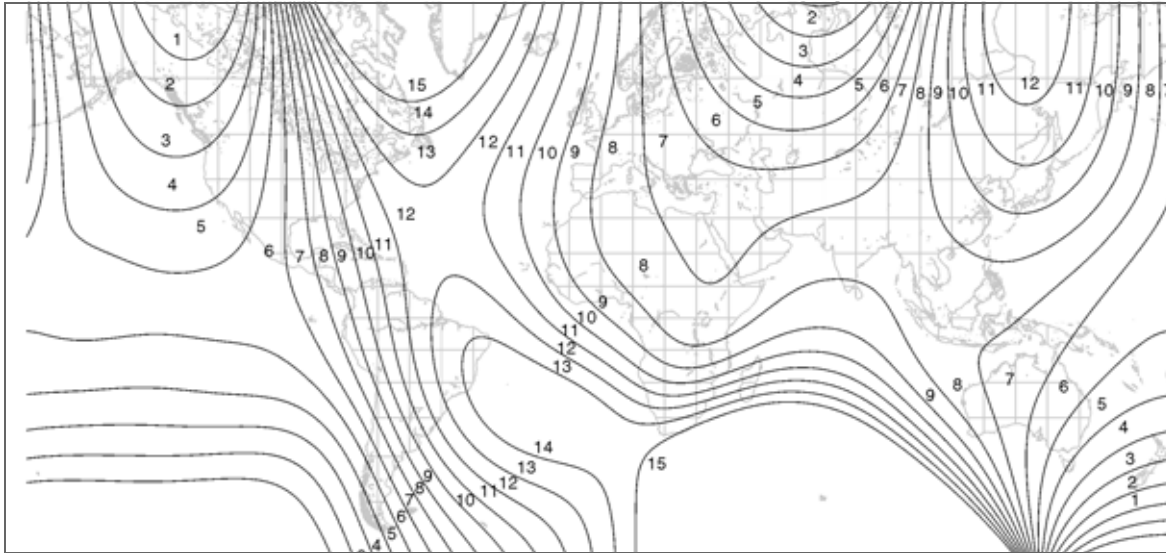

Magnetic zones for the compass

Calibration

The compass may need calibrating to display correctly. For best results, switch off all major power consumers such as interior lighting, ventilation fan, heated rear window etc. and avoid having metal objects and magnetic objects close to the mirror.

- Stop the car in a wide open area with the engine running.
- Press and hold the button on the rear of the mirror (use a paper clip for example) until **CAL** is shown (approx. 6 seconds).
- Drive slowly in a circle at a speed of no more than 8 km/h until **CAL** disappears

from the display, which is when calibration is complete.

Alternative calibration method

Drive off as usual. **CAL** disappears from the display when calibration is complete.

Rearview and door mirrors

Door mirrors

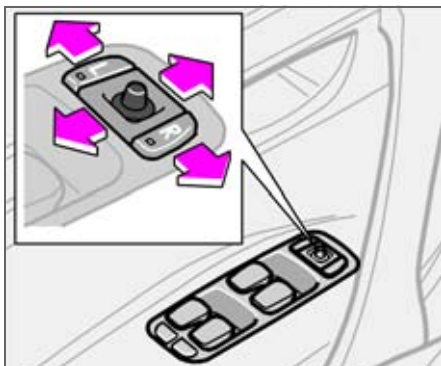

The controls for adjusting the two door mirrors are at the front of the driver's door armrest.

- Press the **L** button for the left-hand door mirror or **R** for the right-hand door mirror. The light in the button illuminates.
- Adjust the position with the joystick in the centre.
- Press the **L** or **R** button again. The lamp goes out.

WARNING

Adjust the mirrors before you begin driving.

Door mirrors with memory function (option)

If the car has door mirrors with memory function, they work together with the memory setting of the seat, see page 83.

WARNING

The driver-side door mirror is wide angled to provide optimal vision. Objects may appear further away than they actually are.

Folding in the door mirrors, see page 47.

Memory function in remote control

When you unlock the car with one of the remote controls and change the setting of the door mirrors, these new settings are saved in the remote control. The next time you unlock the car with the same remote control and open the driver's door within five minutes, the mirrors will assume their stored positions.

Laminated side windows (option)

The laminated windows in the front and rear doors improve sound insulation in the passenger compartment and provide better protection against unauthorised entry.

Water and dirt-repellent coating (option)

The front windows and/or door mirrors are treated with a coating that ensures that the view through the windows or in the mirrors is good even if it is raining.



Side windows and mirrors treated with the water and dirt-repellent coating are marked with a small symbol. For information on glass care, see page 175.

Rearview and door mirrors

In certain weather conditions, the function of the dirt-repellent coating is improved if the door mirror defrosters are used, see page 73 or 75.

Defrost the door mirrors:

- if they are covered with ice or snow.
- in heavy rain and dirty road conditions.
- if they are misted.

IMPORTANT

Do not use a scraper to remove ice from the mirrors as this could scratch the glass and the water and dirt-repellent coating could be damaged.



Power sunroof (option)

Open positions

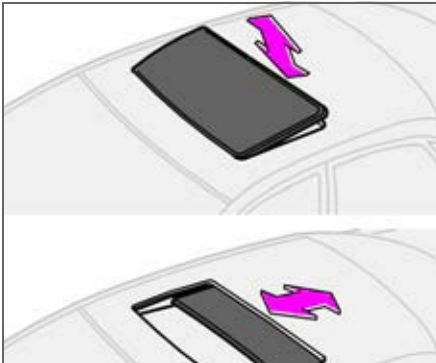

The sunroof controls are located in the roof panel. The sunroof can be opened to two positions:

- Ventilation position, up at the rear edge
- Sliding/comfort position¹, backwards/forwards

The ignition key must be in position I or II.

WARNING

If there are children in the car:

Switch off the supply to the power sunroof by removing the ignition key if the driver leaves the car.

¹ In comfort position, the sunroof is not completely open in order to reduce the level of wind noise.

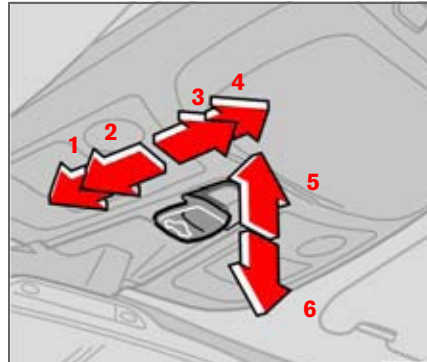

1. Closing, automatic
2. Closing, manual
3. Opening, manual
4. Opening, automatic
5. Opening, ventilation position
6. Closing, ventilation position

Ventilation position

To open:

- Press the rear edge of the control (5) upward.

To close:

- Pull the rear edge of the control (6) downward.

Switch from ventilation position to comfort position; pull the control rearwards to its end position (4) and release.

Sliding position

Automatic operation

- Pull the control past the point of resistance (3) to the rear end position (4) or past the point of resistance (2) to the forward end position (1) and release. The sunroof opens/closes completely.

In order to open from comfort position to maximum opening:

- Pull the control to the rear once more to the end position (4) and release.

Manual operation

To open:

- Pull the control rearward to the point of resistance (3). The sunroof moves toward the fully open position as long as the button is held in this position.

To close:

- Press the control forward to the point of resistance (2). The sunroof moves toward the closed position as long as the button is held in this position.

WARNING

The sunroof's pinch-protection function only operates during automatic closing, not manual.



Power sunroof (option)

Sunscreen

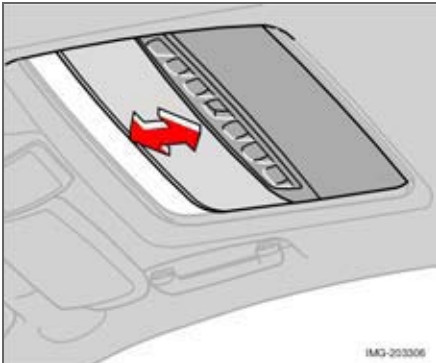

The sunroof features a manual, sliding interior sunscreen. The sunscreen slides back automatically when the sunroof is opened. Grip the handle and slide the screen forwards to close it.

Pinch protection

The sunroof's pinch protection function is activated if the hatch is blocked by an object. If blocked, the sunroof will stop and automatically open to the previous position.



WARNING

The sunroof's pinch protection function only operates during automatic closing, not during manual closing.

Make sure children's hands are clear when closing the sunroof.



02

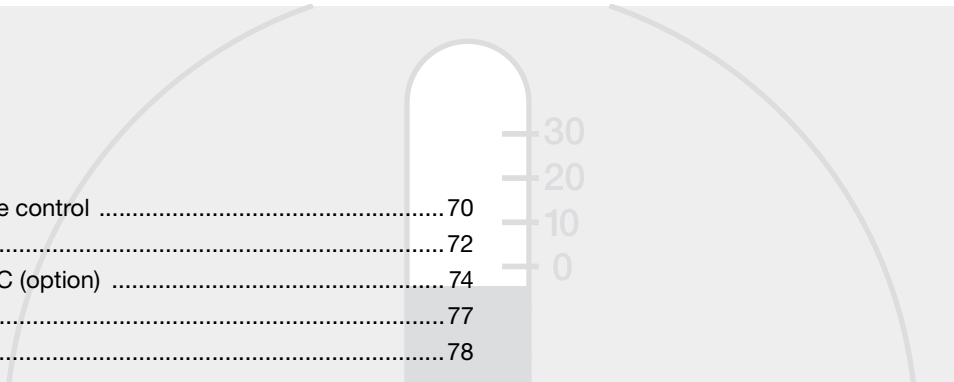

| | |
|--|----|
| General information on climate control | 70 |
| Manual climate control, AC | 72 |
| Electronic climate control, ECC (option) | 74 |
| Air distribution | 77 |
| Fuel-driven heater (option) | 78 |

CLIMATE CONTROL



03





General information on climate control

Air conditioning

The climate control system cools or heats, and dehumidifies the air entering the passenger compartment. The car is equipped with either manual (AC) or electronic climate control (ECC).

i NOTE

The air conditioning can be switched off, but to ensure the best possible air in the passenger compartment and prevent the windows from misting, it should always be on.

Misting windows

Reduce the problem of windows misting up on the inside by cleaning the windows. Use a regular window cleaner.

Particle filter

Make sure that the multifilter/particle filter is replaced regularly. Consult an authorised Volvo workshop.

Ice and snow

Remove ice and snow from the climate control system air intake (the grille between the bonnet and the windscreen).

Fault tracing and repair

Entrust fault tracing and repair of the climate control system to an authorised Volvo workshop only.

Refrigerant

The air conditioning system contains R134a refrigerant. This refrigerant contains no chlorine, which means that it is harmless to the ozone layer. The system must only be charged with R134a refrigerant. Have an authorised Volvo workshop carry out this work.

Cars with ECC

Actual temperature

The temperature you select corresponds to the physical experience with reference to air speed, humidity, exposure to sun, etc. which affect the interior and exterior of the car.

Sensors

The sun sensor is on the upper portion of the instrument panel. Remember not to cover it. Do not cover the passenger compartment temperature sensor on the climate control panel.

Side windows and sunroof

To ensure that the air conditioning works satisfactorily, close all side windows and the sunroof (if fitted). Also, make sure the air ducts in the parcel shelf are not blocked.

Acceleration

The air conditioning system switches off temporarily at full acceleration. You may feel a temporary rise in temperature.

Condensation

In warm weather, condensation from the air conditioning system may drip under the car. This is normal.

Fuel economy

With ECC, the air conditioning system is controlled automatically and is used just enough to cool the passenger compartment and dehumidify the incoming air. This provides better fuel economy compared to conventional systems where the air conditioning cools the air to just above freezing point.



General information on climate control

Air distribution

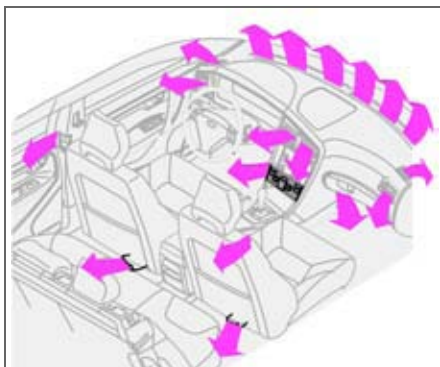

Incoming air is distributed through several different vents located throughout the car.

Panel vents in the instrument panel

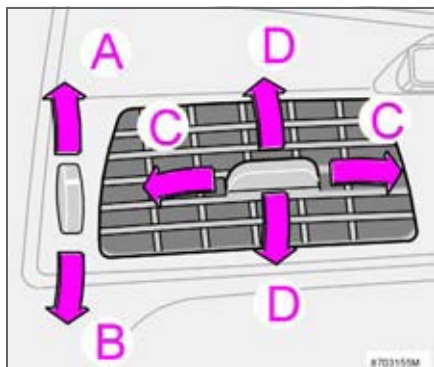

- A. Open
- B. Closed
- C. Lateral airflow
- D. Vertical airflow

Aim the outer vents towards the side windows to remove misting from the front side windows.

Cold weather: Close the centre vents for optimum comfort and best demisting.

Panel vents in the door pillars

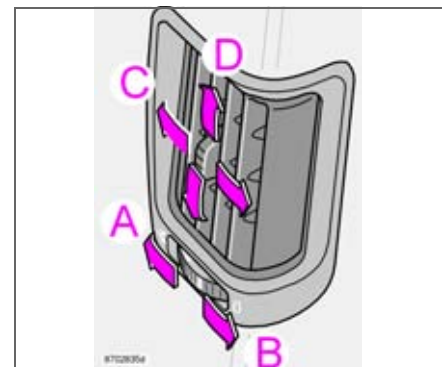

- A. Open
- B. Closed
- C. Lateral airflow
- D. Vertical airflow.

– Aim the vents toward the rear side windows to remove misting.

– Aim the vents inwards in the car for a comfortable climate in the rear seat.

Bear in mind that small children can be sensitive to airflow and draughts.



Manual climate control, AC

Control panel

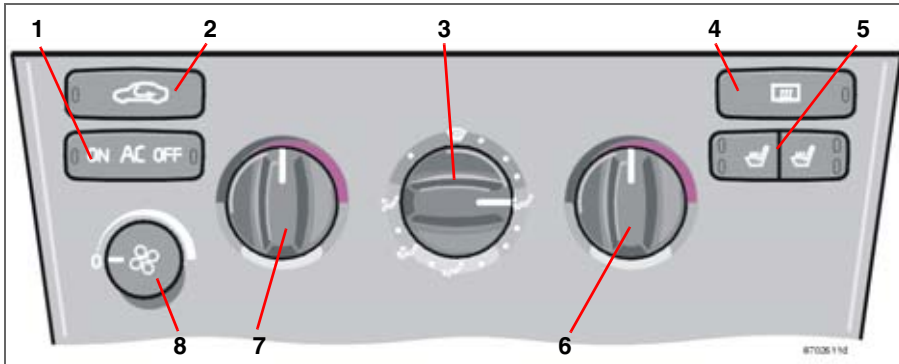

1. AC – ON/OFF
2. Recirculation
3. Air distribution
4. Rear window and door mirror defroster
5. Heated front seats
6. Heating/Cooling – right-hand side
7. Heating/Cooling – left-hand side
8. Fan

You must turn the fan knob (8) from the 0 position to engage the air conditioning.

Use the air conditioning at low temperatures as well (0–15 °C) to dehumidify incoming air.

AC – ON/OFF



ON: The air conditioning is on. It is controlled by the system's AUTO function. This way, incoming air is cooled and dehumidified.

OFF: Off.

When the defroster function is activated the air conditioning is automatically switched on (can be switched off with the A/C button).

Heating/Cooling – left/right-hand side

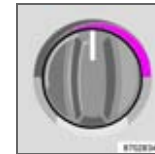

Turn to set how warm or cold the incoming air shall be. For cooler air, the air conditioning must be engaged.



Manual climate control, AC

Heated front seats



Proceed as follows for heated front seat(s):

- Press once: High heat – both lamps in the switch illuminate.
- Press twice: Low heat – one lamp in the switch illuminates.
- Press again: Heating switched off – no lamps in the switch illuminate.

An authorised Volvo workshop can adjust the temperature.

Fan

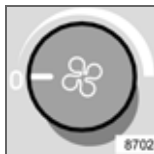

Fan speed can be increased or decreased by turning the knob. If the knob is set to 0 then the air conditioning is not engaged.

Rear window and door mirror defrosters



Use this button to quickly remove misting and ice from the rear window and door mirrors, see page 47 for further information about this

function.

Recirculation





Recirculation can be used to shut out bad air, exhaust, etc. from the passenger compartment. The air in the passenger compartment is

then recirculated, i.e. no air from outside the car is taken into the car when this function is activated. Recirculation (together with the air conditioning system) cools the passenger compartment more quickly in a warm climate.

If you allow the air in the car to recirculate, there is a risk of icing and misting, especially in winter. The timer function minimises the risk of ice, misting and bad air.

Activate the function as follows:

- Press  for more than 3 seconds. The lamp flashes for 5 seconds. The air recirculates in the car for 3–12 minutes depending on the outside temperature.
- The timer function is activated each time you press .

To switch off the timer function:

- Press  again for more than 3 seconds. The lamp illuminates for 5 seconds to confirm your selection.

Air distribution



Use the air distribution control positions (marked with dots) between the different symbols to fine-tune air distribution for maximum comfort.

Defroster



The defroster on the air distribution control is used to quickly remove misting and ice from the windscreen and side windows. Air flows to the windows at high speed.

When the function is selected the following also takes place to provide maximum dehumidification of the air in the passenger compartment:

- the air conditioning (AC) is automatically engaged (can be switched off with the A/C button)
 - recirculation is automatically disengaged.
- When the defroster is switched off, the climate control returns to the previous settings.



Electronic climate control, ECC (option)

Control panel

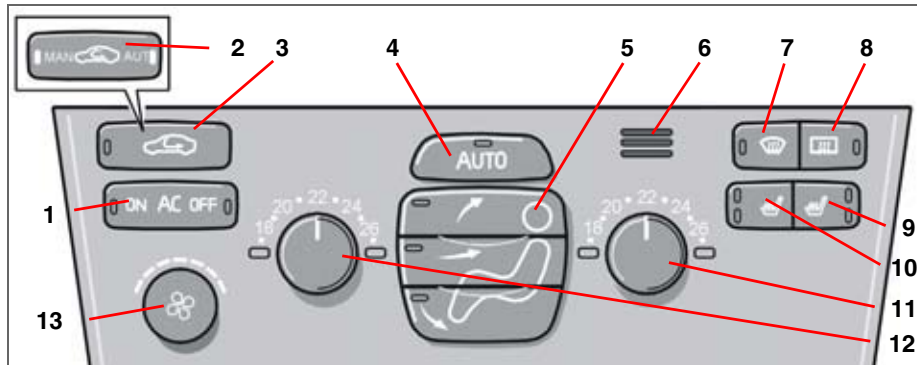

- 1. AC – On/Off
- 2. Recirculation/Multifilter with sensor
- 3. Recirculation
- 4. AUTO
- 5. Air distribution
- 6. Passenger compartment temperature sensor
- 7. Defroster, windscreen and side windows
- 8. Rear window and door mirror defroster
- 9. Seat heater – right-hand side
- 10. Seat heater – left-hand side
- 11. Temperature – right-hand side
- 12. Temperature – left-hand side

13. Fan

AUTO



The AUTO function automatically regulates climate control so that the selected temperature is attained. The automatic function controls heating, air conditioning, air quality sensor, fan speed, recirculation, and air distribution. If you select one or more functions manually, the other functions continue operating automatically. All manual settings are switched off when **AUTO** is pressed.

Temperature



The two knobs can be used to set the temperature for the passenger and driver's sides of the car. Remember that the car does not heat up or cool down any more quickly even if you select a higher or lower temperature than you want in the passenger compartment.



Electronic climate control, ECC (option)

Fan



Fan speed can be increased or decreased by turning the knob. If **AUTO** is selected, fan speed is controlled automatically. The previously set fan speed is disconnected.

NOTE

If the knob for the fan has been turned so far that the left lamp above the knob illuminates with an orange light, the fan and the air conditioning system are switched off.

Rear window and door mirror defrosters



Use this button to quickly remove misting and ice from the rear window and door mirrors, see page 48 for further information

about this function.

Defroster, windscreen and side windows



Used to quickly remove misting and ice from the windscreen and side windows. Air flows to the windows at high speed. The

lamp in the defroster button illuminates when this function is engaged.

When the function is selected, the following also takes place to provide maximum dehumidification of the air in the passenger compartment:

- the air conditioning (AC) is automatically engaged (can be switched off with the **AC** button)
- recirculation is automatically disengaged.

When the defroster  is switched off the climate control returns to the previous settings.

Air distribution



- Air to windows
- Air to head and body
- Air to legs and feet

Press **AUTO** to return to automatic air distribution.

AC – ON/OFF



ON: The air conditioning is on. It is controlled by the system's AUTO function. This way, incoming air is cooled and dehumidified.

OFF: Off.

When the defroster function is activated the air conditioning is automatically switched on (can be switched off with the **AC** button).

Heated front seats



Proceed as follows for heated front seat(s):

- Press once: High heat – both lamps in the switch illuminate.
- Press twice: Low heat – one lamp in the switch illuminates.
- Press again: Heating switched off – no lamps in the switch illuminate.

An authorised Volvo workshop can adjust the temperature.



Electronic climate control, ECC (option)

Recirculation





Recirculation can be used to shut out bad air, exhaust, etc. from the passenger compartment. The air in the passenger compartment is then recirculated, i.e. no air from outside the car is taken into the car when this function is activated.

If you allow the air in the car to recirculate, there is a risk of icing and misting, especially in winter.

The timer function (cars with Multifilter and air quality sensor have no timer function) minimises the risk for ice, misting and bad air.

Activate the function as follows:

- Press  for more than 3 seconds. The lamp flashes for 5 seconds. The air recirculates in the car for 3–12 minutes depending on the outside temperature.
- The timer function is activated each time you press .

To switch off the timer function:

Press  again for more than 3 seconds. The lamp illuminates for 5 seconds to confirm your selection.

Air quality system (option)



The air quality system consists of a multifilter and a sensor. The filter separates gases and particles, thereby reducing the volume of

odours and pollutants entering the passenger compartment. When the sensor detects contaminated outside air, the air intake is closed and the air in the passenger compartment is recirculated.

When the air quality sensor is active, the green **AUTO** lamp illuminates in .

Operation

Press  to activate the air quality sensor (normal setting).

Or:

Select one of the following three functions by pressing  repeatedly.

- The lamp for **AUTO** illuminates. The air quality sensor is now activated.
- No lamp illuminates. Recirculation is not activated unless needed to cool in a warm climate.
- The lamp for **MAN** illuminates. Recirculation is now activated.

Keep the following in mind:





- Make it a rule to have the air quality sensor activated at all times.
- Recirculation is limited in cold weather to avoid misting.
- If misting occurs, you should deactivate the air quality sensor.
- If misting occurs, you can use the defroster functions for the windscreen, side windows and rear window, see page 75.

Follow the Volvo service programme for the recommended replacement interval of the Multifilter. If the car is used in environments where more contaminants are present, it may be necessary to change the Multifilter more often.

03



Air distribution

| Air distribution | Use: | | Air distribution | Use: |
|--|--|---|--|---|
|  <p data-bbox="280 277 539 320">Air through front and rear panel vents.</p> | <p data-bbox="561 277 785 342">When you want good cooling in a warm climate.</p> |  | <p data-bbox="984 277 1235 409">Air to floor. There is a certain amount of airflow to the panel vents and the defroster vents for the windscreen and side windows.</p> | <p data-bbox="1260 277 1484 320">When you want to warm your feet.</p> |
|  <p data-bbox="280 423 539 555">Air to windows Air is not recirculated in this position. Air conditioning is always engaged. There is a certain amount of airflow to the panel vents.</p> | <p data-bbox="561 423 785 510">When you want to remove ice and misting. High fan speed is good for this.</p> |  | <p data-bbox="984 423 1187 465">Air to floor and panel vents.</p> | <p data-bbox="1260 423 1468 488">In sunny weather with cool outside temperatures.</p> |
|  <p data-bbox="280 568 539 656">Air to both floor and windows. There is a certain amount of airflow to the panel vents.</p> | <p data-bbox="561 568 785 678">When you want comfortable conditions and good demisting in a cold climate. Not too low a fan speed.</p> | | | |



Fuel-driven heater (option)

General

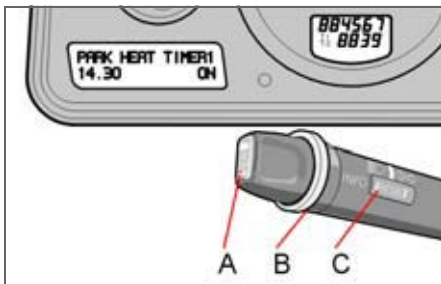

The electrical system must be "awakened" before the parking heater can be programmed.

This is most easily done by:

- pressing the **READ** button or
- activating main beam or
- turning on the ignition.

The parking heater can be started immediately or set with two different start times using **TIMER 1** and **TIMER 2**. Start time refers to the time the car should be heated and ready.

The car's electronic system calculates when heating should be started based on the outside temperature. If the outside temperature exceeds 25 °C, the heater does not switch

on. At temperatures of -10 °C and below, the maximum running time of the parking heater is 60 minutes.

If the parking heater does not start despite repeated attempts, a message is shown in the display. Contact an authorised Volvo workshop.

WARNING

The car must be outdoors when the parking heater is used.

Switch off the parking heater before refuelling. Spilled fuel could be ignited.

Check in the display that the parking heater is off. (When the parking heater is running, **PARK HEAT ON** is shown in the display.)

Messages in the display

Once the settings for **TIMER 1**, **TIMER 2** and **Direct Start** are activated, the amber warning symbol in the combined instrument panel illuminates and explanatory text is shown in the display.

When you leave the car, you will receive a message regarding the current settings of the system. The message disappears when the car is locked from the outside using the remote control.

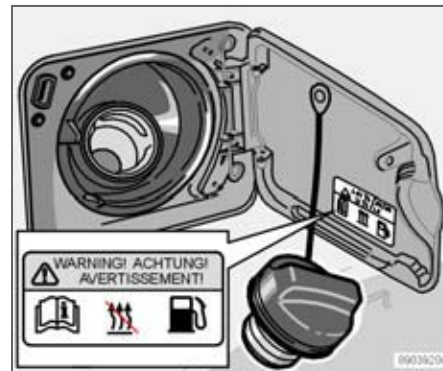

Warning decal on fuel filler flap.

Parking on a hill

If you park your car on a steep incline, the front of the car should be facing up the slope to ensure the supply of fuel to the parking heater.

Car clock/timer

For safety reasons, all timer settings will be cleared if the car clock is reset after timer settings have been made.



Fuel-driven heater (option)

Setting **TIMER 1** and **2**

For reasons of safety, you can only programme times for the following 24 hours, not several days in a row.

- Scroll with the thumbwheel (B) until **TIMER 1** is shown in the display.
- Briefly press the **RESET** button (C) so that the hours setting starts to flash.
- Scroll with the thumbwheel (B) to the desired hour.
- Briefly press the **RESET** button so that the minutes setting starts to flash.
- Scroll with the thumbwheel (B) to the desired minute.
- Briefly press the **RESET** button to confirm your setting.
- Press the **RESET** button to activate the timer.

After setting **TIMER 1**, toggle to **TIMER 2**. Settings are made the same way as for **TIMER 1**.

Deactivating timer-started parking heater

Proceed as follows to manually switch off the parking heater before the set time has elapsed:

- Press the **READ** button (A).

- Scroll with the thumbwheel (B) to the text **PARK HEAT TIMER 1** (or 2). The text **ON** flashes in the display.
- Press the **RESET** button (C). The text **OFF** is shown with a constant glow and the parking heater is switched off.

Direct start of the parking heater

- Scroll with the thumbwheel (B) until **DIRECT START** is shown in the display.
- Press the **RESET** button (C) to make the **ON** and **OFF** options available.
- Select **ON**.

The parking heater will now run for 60 minutes. Heating of the passenger compartment will begin as soon as the engine coolant has reached an adequate temperature.

Deactivating direct-started parking heater

- Scroll with the thumbwheel (B) until **DIRECT START** is shown in the display.
- Press the **RESET** button (C) to make the **ON** and **OFF** options available.
- Select **OFF**.

Battery and fuel

If the battery is not sufficiently charged or the petrol tank is close to empty, the parking heater will be switched off.

If this is the case, a message will appear in the display. Acknowledge the message using the **READ** button (A).

IMPORTANT

Repeated use of the parking heater combined with short journeys may discharge the battery and impair starting. If the parking heater is used regularly, the car must be driven for the same time as the parking heater is used in order to ensure that the alternator has time to charge the battery.

Additional heater (diesel)¹

Extra heat from the additional heater may be required in cold weather to reach the correct temperature in the passenger compartment.

The additional heater starts automatically when extra heat is required if the engine is running. It is switched off automatically when the correct temperature is reached or when the engine is switched off.

¹ Certain countries

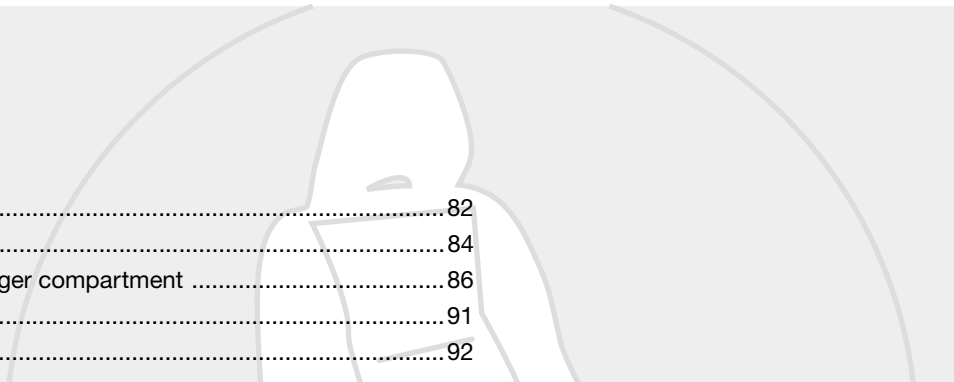

| | |
|---|----|
| Front seats | 82 |
| Interior lighting | 84 |
| Storage spaces in the passenger compartment | 86 |
| Rear seat | 91 |
| Cargo area | 92 |

INTERIOR



04





Front seats

Seating position



The driver's and passenger seats can be adjusted to the optimum sitting and driving positions

1. Forward/backward: lift the handle to adjust the distance to the steering wheel and pedals. Check that the seat is locked after changing position.
2. Raise/lower front edge of seat cushion: pump up/down¹.
3. Raise/lower seat: pump up/down.
4. Lumbar support², turn the wheel.

¹ The control panel (2) is not available with certain upholstery alternatives.

² Also applies to power seat.

5. Backrest rake: turn the wheel.
6. Control panel for power seat.

WARNING

Adjust the position of the driver's seat before setting off, never while driving. Check that the seat is locked in position.

Lowering the front seat backrest (option)

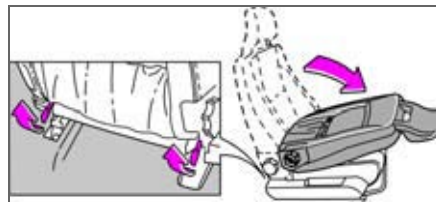

The passenger seat backrest can be folded forward to make room for long loads.

- Move the seat as far back as possible.
- Adjust the backrest to an upright position 90 degrees.
- Lift the catches on the rear of the backrest while folding it forwards.
- Slide the seat forward so that the head restraint is "locked in place" under the glovebox.

Floor mats (option)

Volvo supplies floor mats especially produced for your car.

WARNING

The floor mat at the driver's seat must be firmly fitted and secured in the attachment clips to prevent it from being trapped around and under the pedals.



Front seats

Power seat (option)

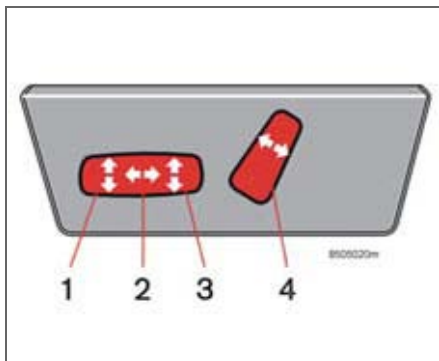

The seats can be adjusted for a certain time after unlocking the door with the remote control without the key being inserted into the ignition switch. The seats can always be set when the ignition is on.

Power seat (option)

1. Front edge of seat cushion up/down
2. Seat forward/rearward
3. Seat up/down
4. Backrest rake

Overload protection is deployed if any seat is blocked. If this occurs, switch off the ignition and wait a short time before operating the

seat again. Only one of the seat's motors can be used at a time.

Seat with memory function (option)

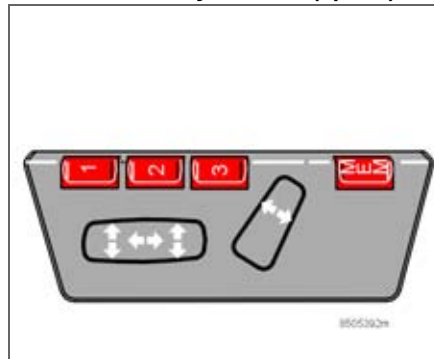

Buttons for memory function

Store setting

- Adjust seat.
- Press and hold button **MEM** while pressing button **1**, **2** or **3** at the same time.

Using a stored setting

Press one of the memory buttons **1** – **3** until the seat stops. If you release the button then the movement of the seat will stop.

Key memory in remote control key

The driver's seat positions are stored in the key memory when the car has been locked with the remote control key. When the car is unlocked with the same remote control key the driver's seat and rearview mirrors adopt the stored positions when the driver's door is opened.

NOTE

The key memory is independent of the seat memory.

Emergency stop

If the seat accidentally begins to move, press one of the buttons to stop the function.

WARNING

Risk of crushing. Make sure that children do not play with the controls. Check that there are no objects in front of, behind or under the seat during adjustment. Ensure that none of the rear seat passengers can be trapped.



Interior lighting

Reading lamps and interior lighting

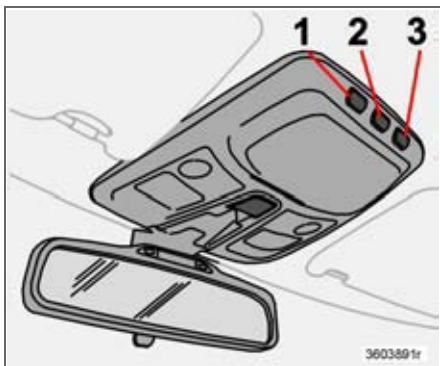

Passenger compartment lighting and reading lamps.

1. Reading lamp left-hand front
2. Interior lighting
3. Reading lamp right-hand front

The front reading lamps are switched on and off using button (1) or (3).

The interior lighting is switched on and off with a short press on button (2).

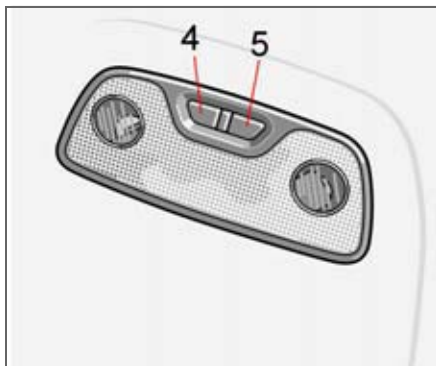

Rear reading lamps

4. Reading lamp left-hand rear
5. Reading lamp right-hand rear

The rear reading lamps are switched on and off using button (4) or (5).

Automatic lighting

All reading lamps and interior lighting are switched off automatically after 10 minutes from when the engine is switched off. Each type of lighting can be switched off manually before this.

The interior lighting is switched on automatically¹ and remains on for 30 seconds when:

- the car is unlocked from the outside using the key or remote control
- the engine is switched off and the key is turned to the 0 position.

The interior lighting is switched on and remains on for 10 minutes when:

- one of the doors is open if the interior lighting is not switched off.

The interior lighting is switched off when:

- the engine is started
- when the car is locked from the outside using the key or remote control.

Automatic lighting can be disengaged by pressing and holding button (2) for more than 3 seconds. A short press on the button re-engages automatic lighting.

The programmed times, 30 seconds and 10 minutes, can be changed by a Volvo workshop.

¹ The function is light-dependent and is only activated when it is dark.



Vanity mirror¹

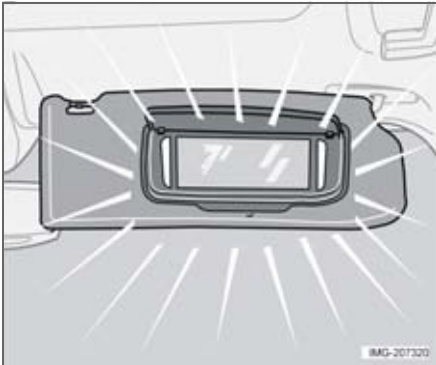

The light illuminates automatically when the cover is lifted.

¹ Option in certain markets.



Storage spaces in the passenger compartment

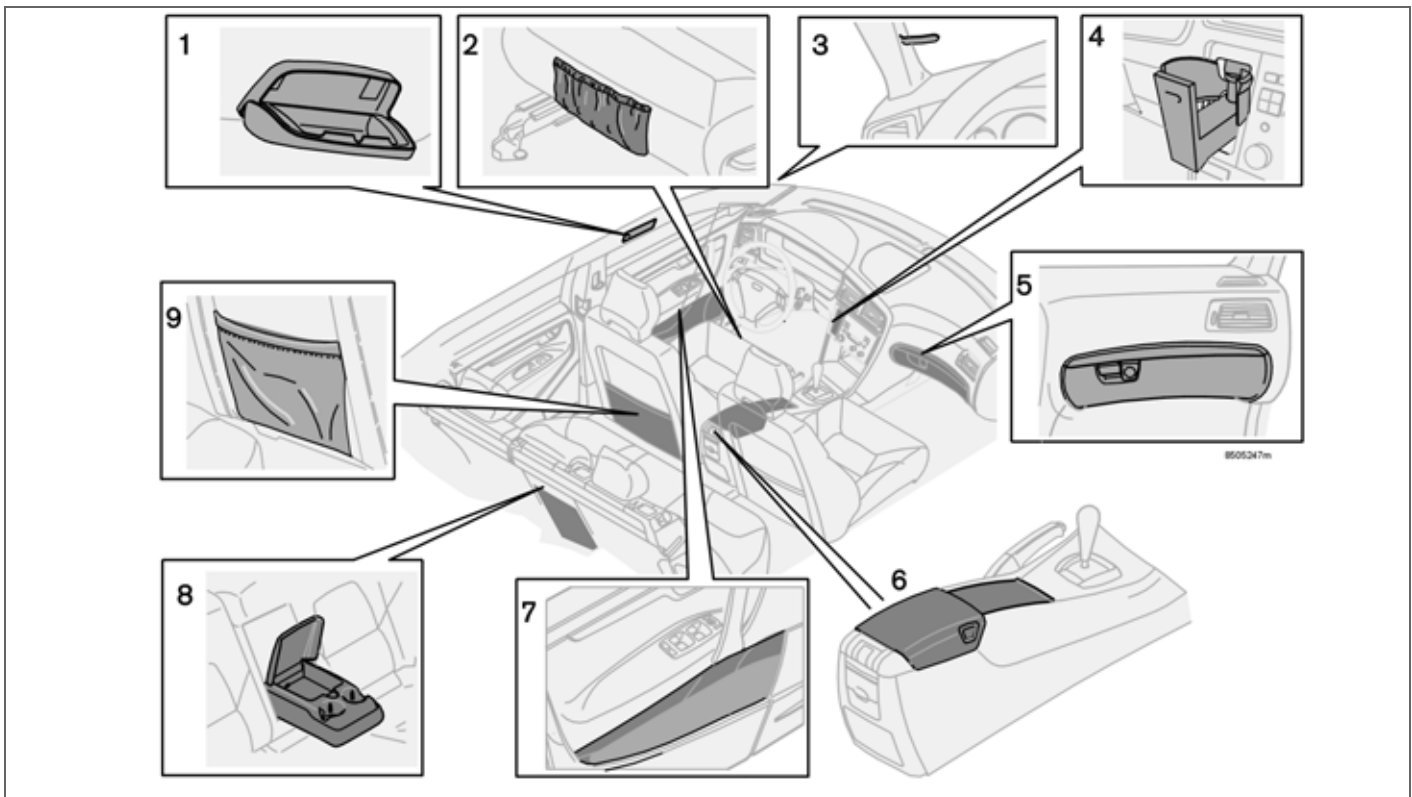



Storage spaces in the passenger compartment

Storage spaces

1. Sunglasses compartment, driver's side (option).
2. Storage pocket.
3. Ticket clip.
4. Cup holder (option).
5. Glovebox.
6. Storage compartment in the centre console.
7. Compartment in door panel.
8. Cup holder in the armrest, rear seat.
9. Storage pocket.



WARNING

Ensure that no hard, sharp or heavy objects lie or protrude in such a way that they could cause injury during heavy braking.

Always secure large and heavy objects with a seatbelt or cargo retaining straps.

Storage compartment in centre console

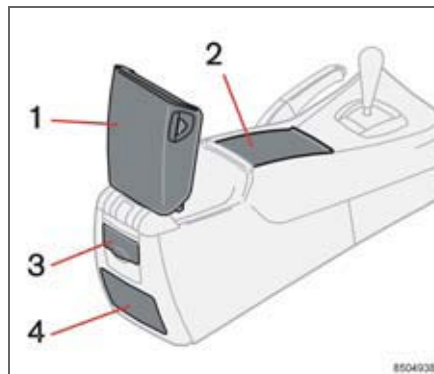

1. Rear storage compartment
The rear storage compartment of the centre console can be used to store CDs and similar. This storage compartment can be equipped with privacy handset + holder (option)
2. Front storage compartment (roller cover)
This storage compartment can be equipped with the following options:
 - Cup holder (option)
 - Ashtray (option)
3. 12 V socket
4. Ashtray (option)

Rear storage compartment cup holder for rear seat passengers

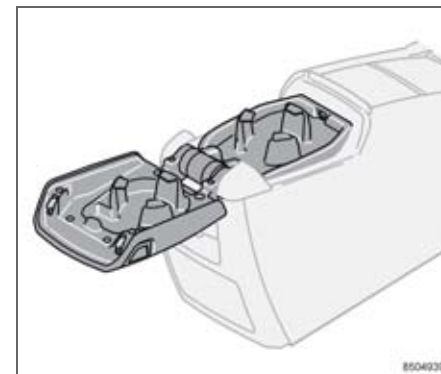

To access the storage compartment/privacy handset, press the button on the left-hand side of the armrest and fold the tunnel compartment cover back.

To use the cup holder, press the button on the right-hand side of the armrest and fold the upper part of the tunnel compartment cover back. The cup holder and cover can be closed separately.



Storage spaces in the passenger compartment

Cup holder in front storage compartment (option)

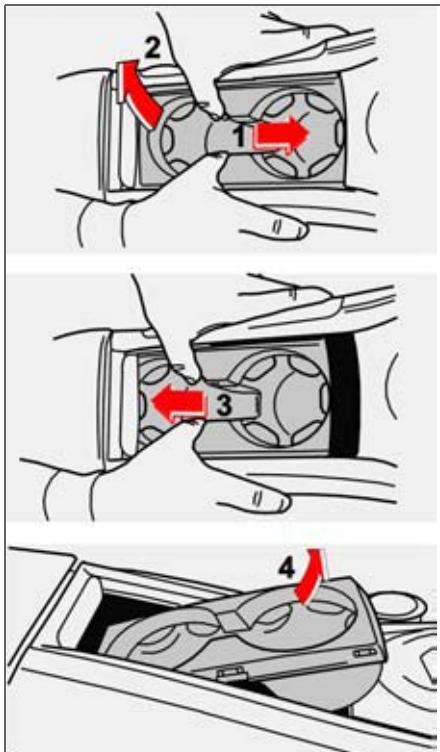

The cup holder can be easily removed:

- Press the cup holder forwards (1), while lifting it at the rear edge (2).
- Push the cup holder back (3), into the cut-out, under the roller cover.
- Angle the front edge (4) of the cup holder up and lift out.

Repeat the procedure in reverse order to refit the cup holder.

Instrument panel cup holder (option)

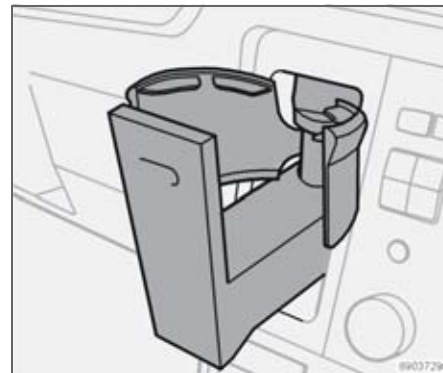

- Press the holder to open.
- Press the holder in after use.

NOTE

Never use glass bottles. Remember also that hot drinks may cause burns.



Storage spaces in the passenger compartment

Glovebox

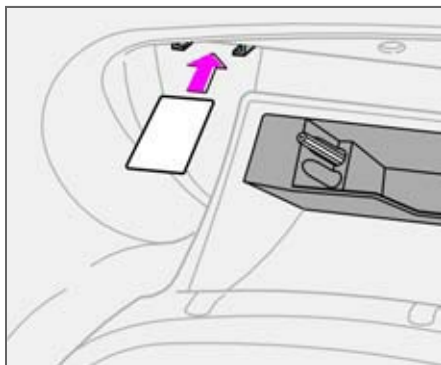

The glovebox can be used to store things such as the owner's manual, maps, pens and petrol cards.

Coat hanger

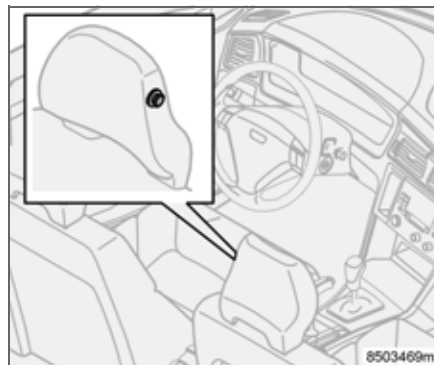

The coat hanger is only intended for light garments.

Bottle holder for rear seat passengers (option)

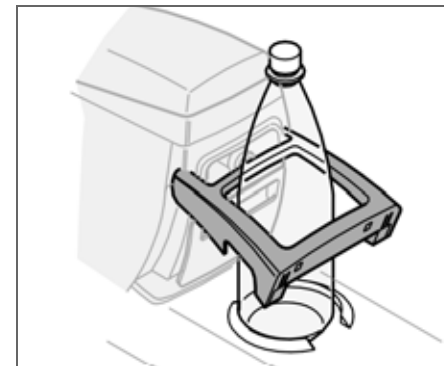

Proceed as follows to use the bottle holder:

- Open the holder.
- Insert the bottle.

The bottle holder can also serve as a waste bin. Insert a bag into the holder and fold it over the edges.

i NOTE

The bin does not require special bags. Use a regular plastic bag.



Storage spaces in the passenger compartment

Cup holder in armrest, rear seat
(option)



04



Head restraints in the rear seat

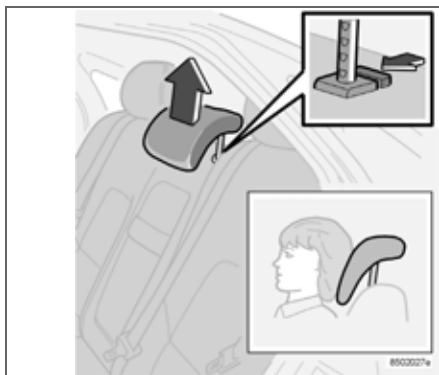

Adjusting the vertical position of the head restraint.

The centre seat head restraint can be adjusted vertically to suit the height of the passenger. Raise the head restraint as needed. The release button on one of the supports must be pressed to push the head restraint down. See the illustration!

Lowering the rear seat backrest

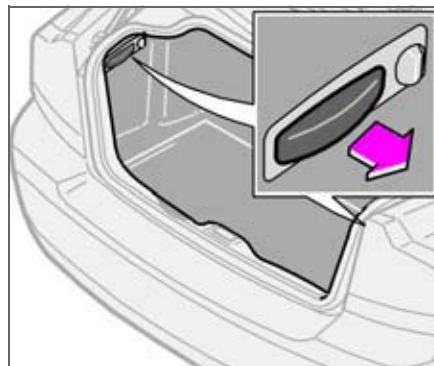

Both rear seat backrests can be tipped forward, together or individually. This makes it easier to transport long objects.

Fold the rear seat backrests as follows:

- First check that the head restraints have not been lowered.
- Pull the handle in the cargo area as shown in the illustration.
- Fold the backrest forward.

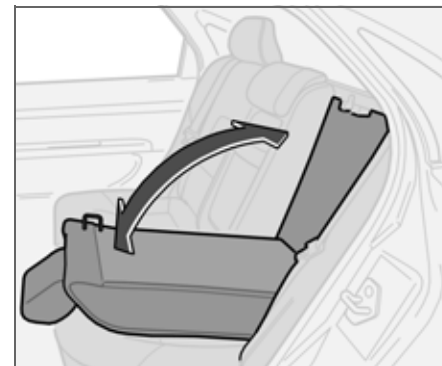

A hatch in the right-hand rear backrest allows you to transport long objects such as skis and planks. Open the hatch as follows:

- Fold the left-hand backrest and centre armrest forwards.
- Release the hatch by pushing the catch upward while folding the hatch forward.
- Tip the backrest back into position with the hatch open.



Cargo area

Hatch for long objects

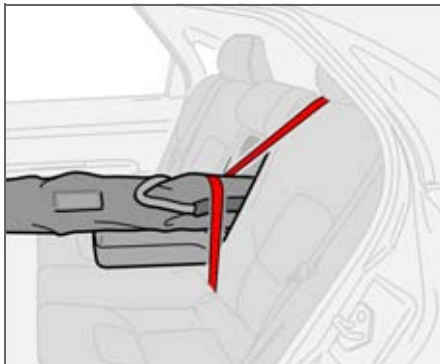

Use the seatbelt to secure the load.

Integrated booster cushion

The cover on the armrest/child seat has no hinge. The cover must be removed before the ski hatch is used.

NOTE

If the car is equipped with integrated booster cushion, fold this out first.

When removing

- Open the cover 30°.
- Pull straight up.

When fitting

- Move the cover back in the grooves behind the upholstery.
- Close the cover.

WARNING

Always secure the load. During heavy braking the load may otherwise shift, causing personal injury.

Cover sharp edges with something soft.

Turn off the engine and apply the parking brake when loading or unloading long objects! Otherwise you may accidentally knock the gear lever or gear selector with the load and cause a gear to engage and the car to move off.

Carrier bag holder (option)

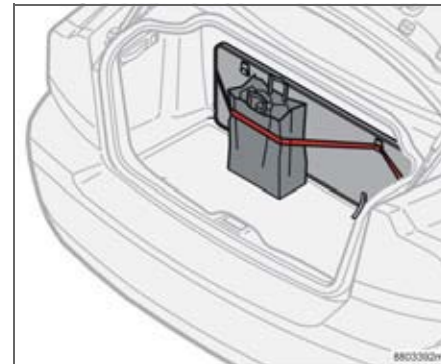

Open the hatch in the cargo area. Hang or secure your grocery bags using the tensioning strap.

General

Payload depends on the car's total kerb weight, including any accessories that are mounted.

Kerb weight includes the driver, the weight of the fuel tank when filled to 90 % and various fluids, such as washer fluid and coolant.

Mounted accessories, i.e. towbar, load carriers, space box, etc., are included in the kerb weight.

**Cargo area**

The load capacity of the car is reduced by the number of passengers and their weight.

**WARNING**

The driving characteristics of the car change based on its kerb weight and how heavily it is loaded.



| | |
|--------------------------------|-----|
| Keys and remote controls | 96 |
| Locking and unlocking | 99 |
| Child safety locks | 103 |
| Alarm (option) | 104 |

LOCKS AND ALARM



05



Keys and remote controls

Keys

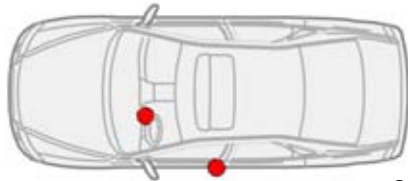
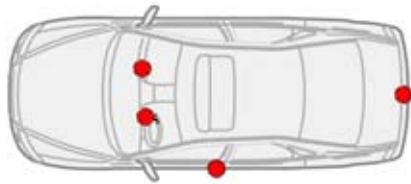

1. Master key
This key opens all locks.
 2. Service key¹
This key is for the front door, ignition switch and steering wheel lock only.
- Your car is delivered with two master keys and one service key¹. One of the master keys is collapsible and equipped with an integrated remote control.

Loss of key

If you should lose one of your keys, bring the remaining keys to an authorised Volvo workshop. As a crime prevention measure, the code for the lost key is erased from the system and the other keys must be re-coded in the system.

The key blades' unique code is available at authorised Volvo workshops, who can order new key blades.

A maximum of six remote controls/key blades can be programmed and used for one single car.

Immobiliser

The keys are equipped with coded chips. This code must match the reader in the ignition switch. The car can only be started if the correct key with the correct code is used.

¹ Certain markets only.



NOTE

The master key blade (1) must be fully extended (as illustrated) when starting the car. Otherwise there is a risk that the immobiliser function will prevent the car from starting.

Ignition keys and electronic immobiliser

The ignition key must not hang with other keys or metal objects on the same key ring. The electronic immobiliser could be activated erroneously and the car will not start.



Keys and remote controls

Remote control functions

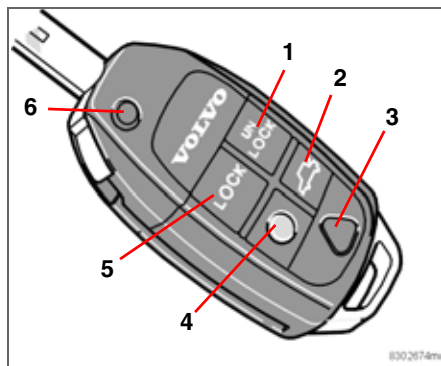

Unlocking

Press the button (1) once to unlock all doors, the boot lid and the fuel filler flap.

Boot lid

Press the button (2) twice to unlock the boot lid only.

Panic alarm function

The panic alarm function can be used to attract attention in an emergency.

Press and hold the red button (3) for at least three seconds or press it twice during the

same time to activate the direction indicators and the horn.

The panic alarm is deactivated automatically after 25 seconds or by pressing any of the buttons on the remote control.

Approach lighting

Do the following when you approach the car:

- Press the yellow button (4) on the remote control.

The interior lighting, position/parking lamps, number plate lighting and door mirror lamps (option) will switch on. These lamps will remain lit for 30, 60 or 90 seconds. An authorised Volvo workshop can select a suitable time setting.

To extinguish the approach lighting:

- Press the yellow button again.

Locking

Lock all doors, boot lid and fuel filler flap with button (5).

There is a delay of approx. 10 minutes for the fuel filler flap.

Folding/opening key

The key can be folded by pressing button (6) while folding the key blade into the keypad.

The folding key will open automatically with one press of the button.



Keys and remote controls

Changing the remote control battery

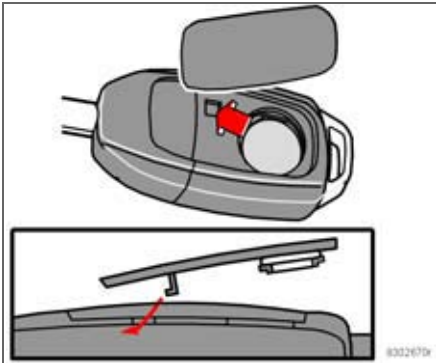

Turn the old battery in to your Volvo workshop so that it can be disposed of in an environmentally friendly manner.

Replace the battery after repeated failure by the locks to respond when remote control signals are transmitted within a normal distance.

- Remove the cover by carefully prising up the rear edge of with a small screwdriver.
- Replace the battery (type CR 2032, 3 V) – with the plus side facing up. Avoid touching the battery and its contact surfaces with your fingers.
- Refit the cover. Make sure the rubber seal is properly fitted and free from damage to prevent water from entering.



Locking and unlocking

Locking/unlocking the car from outside

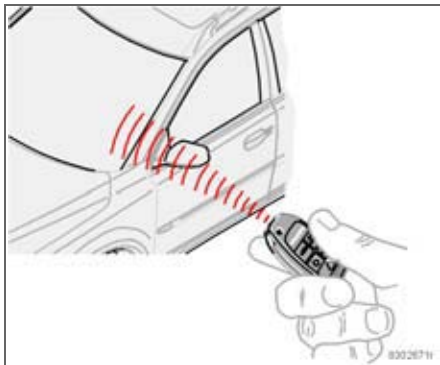

The master key or remote control locks/unlocks all side doors and the boot lid simultaneously. The side door lock buttons and inside handles are disengaged.¹

The fuel filler flap can be opened when the car is unlocked. The flap remains unlocked for 10 minutes after the car has been locked.

The car can be locked¹ even if a door or the boot lid is open. When the door is closed there is a risk that the keys will be locked in.

¹ Applies to certain markets

Automatic relocking

If none of the doors or the boot lid is opened within two minutes of unlocking, all are locked again automatically. This function prevents the car from being left unlocked unintentionally. For cars with alarms, see page 104.

Automatic locking

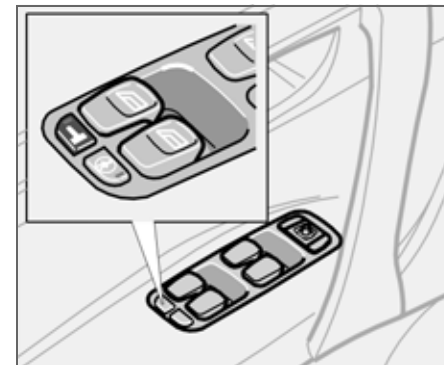

Automatic locking is activated and deactivated from the control panel in the driver's door.

The function operates by locking the doors automatically when the speed of the car exceeds 7 km/h. They remain locked until a door is opened from the inside or when all doors are unlocked from the control panel.

Activating/deactivating automatic locking

- The ignition key must be in position **I** or **II**.
- Press the **READ** button in the left-hand stalk switch to acknowledge any messages in the display.



Locking and unlocking

- Press and hold the button for central locking until a new message for lock status is shown in the display.

The messages **AUTOLOCK ACTIVATED** (the car is also locked when it moves) and **AUTOLOCK DEACTIVATED** respectively are shown in the display.

Locking and unlocking the car from the inside

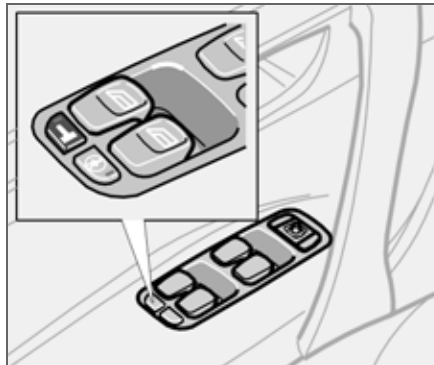

All the doors and the boot lid can be locked or unlocked simultaneously using the control panel in the driver's door (or passenger door).

All doors can be locked using the lock button on the control panel by each respective door.

If the car is not locked from the outside then it can be unlocked by opening the door with the handle.¹

Unlocking/locking the boot lid with the remote control

Proceed as follows in order to unlock the boot lid only:

- Press twice on the remote control button to open the boot lid. The boot lid is unlocked and opened slightly at the same time.

If all doors are locked when the boot lid closes, it locks automatically.

¹ Applies to certain markets



Locking and unlocking

Unlocking the boot lid with the master key



The master key should be used when unlocking the boot lid manually during emergencies only, e.g. if the remote control does not function or the car is without power. Open the boot lid as follows:

- Insert the master key into the upper or lower section of the lid covering the lock.
- Twist up or down in order to prise the lid off.
- Unlock the boot lid.

Service locking, boot lid (certain countries)



This function is beneficial if the car is left for service, with a hotel parking valet or the like. The service key is left with the staff, who can open and drive the car but do not have access to the boot lid (or the glovebox if it is locked with the master key).

To activate service locking

- Turn the master key to position **II**.
- Press the button. A lamp in the button illuminates when the function is activated and a message is shown in the display.

To deactivate service locking

- Turn the master key to position **II** and press the button again.

Locking the glovebox

The glovebox can only be locked/opened using the master key – not with the service key.

Deadlocks¹

Your car has a special deadlock function, which means that the doors cannot be opened from the inside if they are locked.

Deadlocks can only be activated from the outside by the driver's door being locked with the key or remote control. All doors must be closed before deadlocks can be activated. Once activated, the doors cannot be opened from the inside. The car can only be unlocked from the outside via the driver's door or by using the remote control.

Deadlocks are engaged after a 25 second delay once the doors have been closed

¹ Certain countries



Locking and unlocking

Temporary deactivation of the deadlocks and any detectors

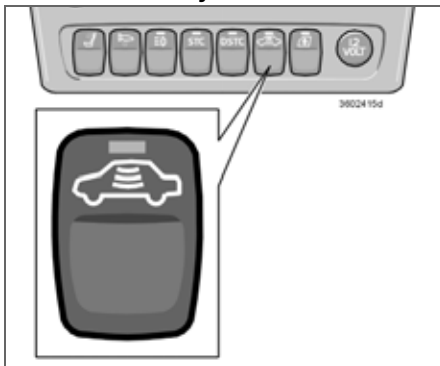

A message is shown in the display as long as the key remains in the ignition switch. The sensors will be reactivated the next time the ignition is switched on.

WARNING

Do not allow anyone to remain in the car without first deactivating the deadlock.

If others prefer to remain seated in the car with the doors locked from the outside – e.g. during transport by ferry – it is possible to deactivate the deadlocks.

- Insert the key into the ignition switch, turn it to position **II** and then back to position **I** or **0**.
- Press the button.

If the car is equipped with an alarm, movement and tilt detectors are also deactivated. See page 105.

The lamp in the button illuminates until the car is locked with the key or remote control.

05



Child safety locks

Mechanical child safety locks – rear doors

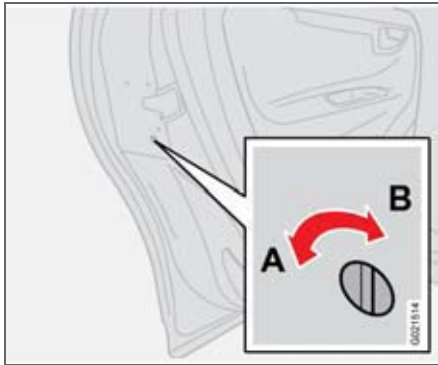

Control for child safety lock – left-hand rear door.

The controls for the child safety locks are in the rear edge of each rear door and are only accessible when the door is open. Use a flat metal object, such as a screwdriver, to turn the control and thus activate or deactivate the child safety lock.

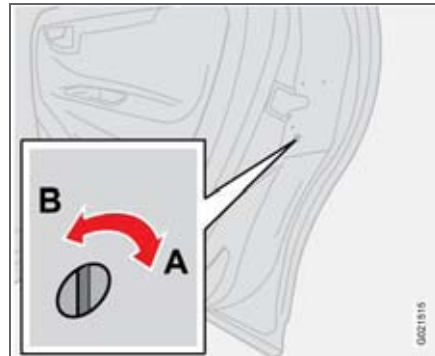

Child safety lock controls – right-hand rear door.

- A. Child-safe position – the doors cannot be opened from inside; turn outwards.
- B. Not child-safe position – the doors can be opened from inside; turn inwards.



WARNING

Remember that in the event of an accident, rear seat passengers cannot open the rear doors from the inside if the child safety locks are activated.

Therefore, keep the doors unlocked while driving. In the event of an accident, rescue personnel will then be able to enter the car from the outside.



Alarm (option)

The alarm system

When the alarm is armed, it continually monitors all alarm inputs. The alarm is triggered if:

- the bonnet is opened.
- the boot lid is opened.
- a side door is opened.
- the ignition switch is turned with a non-approved key or subjected to force.
- movement is detected in the passenger compartment (if a motion sensor is fitted – option for certain markets only).
- the car is raised or towed away (if a tilt sensor is fitted – option for certain markets only).
- a battery cable is disconnected.
- anyone tries to disconnect the siren.

Activating the alarm

Press the **LOCK** button on the remote control. A long flash signal from the direction indicators of the car confirms that the alarm is armed and all doors are closed. In certain markets, the key or the control in the driver's door can be used to arm the alarm.



IMPORTANT

The alarm is fully armed when the car's direction indicators have made one long flash and the light on the instrument panel flashes once every other second.

Deactivating the alarm

Press the **UNLOCK** button on the remote control. Two short flashes from the car's direction indicators confirm that the alarm has been deactivated.

If the remote control batteries are discharged then the alarm can be disarmed by turning the key to ignition position **II**.

Automatic alarm activation

If none of the doors or the boot lid is opened within two minutes of the alarm being disarmed, and the car was unlocked with the remote control, the car re-arms the alarm automatically. The car locks at the same time. This function prevents you from accidentally leaving the car without the alarm on.

In certain countries (e.g. Belgium, Israel) the alarm is reactivated after a certain delay if the driver's door was opened and closed but the car was not re-locked.

Deactivating a triggered alarm

Press the **UNLOCK** button on the remote control if the alarm sounds and you wish to deactivate it. Two short flashes of the direction indicators signal confirmation.

Audio signal – Alarm

The audio signal is given from a siren with a reserve battery. Each alarm signal lasts 25 seconds.

Visual signal – Alarm

When the alarm is triggered, all direction indicators flash for 5 minutes or until the alarm is deactivated as described earlier.

**Alarm (option)****Temporary deactivation of detectors and deadlocks**

To avoid inadvertently triggering of the alarm, for example when leaving a dog in the car or during a ferry crossing, the movement and tilt detectors can be temporarily deactivated:

1. Insert the key in the ignition switch, turn it to position **II** and then back to position **I** or **0**.
2. Press the button.

The lamp in the button is illuminated until you lock the car with the key or remote control.

A message will be shown in the display as long as the key remains in the ignition switch.

The sensors will be reactivated when the ignition is restarted.

If your car has deadlocks, they are reactivated at the same time. See page 101.

Indicator lamp on the instrument panel (certain countries)

An indicator lamp at the top of the instrument panel indicates alarm status:

- Lamp not lit: Alarm is deactivated.
- The lamp flashes once every other second after the car's direction indicators have made one long flash signal: Alarm is armed.
- Lamp flashes quickly, after deactivating the alarm and until the ignition is switched on: The alarm has been triggered.

If there is a fault in the alarm system, a message appears in the display.

If the alarm system does not function correctly, have an authorised Volvo workshop examine the car.

**IMPORTANT**

Do not attempt to repair or modify alarm system components. All such attempts can affect terms of insurance.



Alarm (option)

Testing the alarm system

Testing the passenger compartment motion sensor:

- Open all the windows.
- Activate the alarm. Alarm activation is confirmed with a slow flash of the lamp.
- Wait 30 seconds.
- Test the movement detector in the passenger compartment by lifting a bag or similar from the seat cushion. The alarm will now sound and flash.
- Deactivate the alarm by unlocking the car with the remote control.

Testing the doors

- Arm the alarm.
- Wait 30 seconds.
- Unlock the driver's door with the key blade.
- Open one of the doors. The alarm system will sound and flash.
- Repeat the test for the other doors.
- Deactivate the alarm by unlocking the car with the remote control.

Testing the bonnet

- Get into the car and deactivate the movement detector.
- Arm the alarm (remain in the car and lock the doors with the button on the remote control).
- Wait 30 seconds.
- Open the bonnet with the handle under the instrument panel. The alarm will now sound and flash.
- Deactivate the alarm by unlocking the car with the remote control.

Testing the boot lid:

- Arm the alarm.
- Wait 30 seconds.
- Unlock with the key on the driver's side without opening any of the doors.
- Open the boot lid with the handle. The alarm will now sound and flash.
- Deactivate the alarm by unlocking the car with the remote control.



| | |
|---|-----|
| General | 110 |
| Refuelling | 112 |
| Starting the car | 114 |
| Manual gearbox | 116 |
| Automatic gearbox | 117 |
| All-wheel drive – AWD | 121 |
| Brake system | 122 |
| Stability and traction control system, option | 124 |
| Active chassis – FOUR-C | 126 |
| Parking assistance | 127 |
| Towing and recovery | 129 |
| Start assistance | 131 |
| Driving with a trailer | 132 |
| Towing equipment | 134 |
| Detachable towbar | 136 |
| Load on the roof | 141 |
| Adjusting headlamp pattern | 143 |
| BLIS (Blind Spot Information System) – option | 149 |

STARTING AND DRIVING



06



General

Economical driving

Economical driving results from driving gently with anticipation and adapting your driving style and speed to the situation.

Keep in mind the following:

- Drive the engine to operating temperature as soon as possible! That is to say: do not let the engine idle, but drive with a light load as soon as you can.
- A cold engine consumes more fuel than a warm one.
- Avoid driving short distances where the engine never has time to reach operating temperature.
- Drive gently! Avoid unnecessary quick accelerations and heavy braking.
- Do not drive with unnecessary, heavy loads in the car.
- Do not use winter tyres when the roads are clear and dry.
- Remove the load carrier when it is not in use.
- Do not open side windows unnecessarily.

Do not drive with an open boot lid!

If you drive with the boot lid open, some of the exhaust gases and poisonous carbon monoxide could be sucked into the car through the cargo area. If you must drive a short distance with the boot lid open, proceed as follows:

- Close all windows.
- Distribute the air between the windscreen and floor while running the fan at high speed.

Your new car – slippery road surfaces

Driving on a slippery road may feel different depending on whether you choose a car with a manual or an automatic gearbox. Practice skid driving under controlled conditions so that you know how your new car reacts.

Driving in water

The car can be driven through water at a maximum depth of 25 cm at a maximum speed of 10 km/h. Extra caution should be exercised when passing through flowing water.



IMPORTANT

Engine damage can occur if water enters the air filter.

In greater depths, water can enter the transmission. This reduces the lubricating ability of the oils and shortens the service life of these systems.

When driving in water, maintain a low speed and do not stop the car. When the water has been passed, depress the brake pedal lightly and check that full brake function is achieved. Water and mud for example can make the brake linings wet resulting in delayed brake function.



NOTE

Clean the electric contacts of the electric engine block heater and trailer coupling after driving in water and mud.



IMPORTANT

Do not let the car stand with water over the sills for any long period of time. This could cause electrical malfunctions.

In the event of stalling in water, do not try to restart. Tow the car out of the water.



Do not overload the battery

The electrical functions in the car load the battery to varying degrees. Avoid having the ignition key in position **II** when the engine is turned off. Use position **I** instead, as less power is used. The 12 volt outlet in the cargo area supplies power even when the ignition key is removed.

Examples of functions that use a lot of power:

- ventilation fan
- windscreen wipers
- audio system
- parking lights

Also, be aware of different accessories that load the electrical system. Do not use functions which use a lot of power when the engine is switched off.

A text is shown in the display in the combined instrument panel if battery voltage is low and remains until the engine has started.

The energy-saving function shuts down certain functions or reduces the load on the battery by, for example, slowing the ventilation fan and switching off the audio system.

Charge the battery by starting the engine.

Do not allow the engine and cooling system to overheat

Under certain conditions, e.g. when driving in hilly terrain and with a heavy load, especially in warm weather, there is a risk of the engine and cooling system overheating.

To avoid overheating in the cooling system:

- Drive at low speeds if driving with a trailer up a long incline.
- Switch off the air conditioning temporarily.
- Avoid letting the engine idle.
- Do not turn the engine off immediately you stop, if the car has been driven hard.
- Remove any auxiliary lamps from in front of the grille if driving in extreme high temperatures.

To avoid the engine overheating:

Do not exceed engine speeds of 4500 rpm (diesel engine: 3500 rpm) if driving with a trailer or caravan in hilly terrain. The oil temperature can become too high.



Refuelling

Opening the fuel filler flap

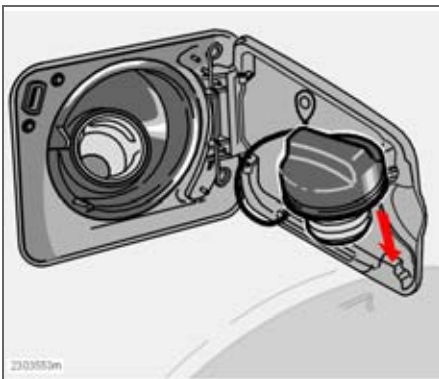

The fuel cap is inside the fuel filler flap on the right-hand rear wing and hangs up on the inside of the fuel filler flap.

The fuel filler flap can be opened when the car is unlocked.

i NOTE

The filler flap remains unlocked for ten minutes after the car has been locked.

Fuel filler flap

High outside temperatures can cause some overpressure in the tank. Open the cap slowly.

i NOTE

After refuelling, replace the fuel cap and turn until one or more clicks is heard.

! WARNING

Never carry an activated mobile phone when refuelling – the ring signal could cause spark build-up and ignite petrol fumes, leading to fire and injury.

Refuelling with petrol

Do not overfill the tank but fill until the pump nozzle cuts out.

i NOTE

Excess fuel in the tank can overflow in hot weather.

Do not add cleaning additives unless specifically recommended by a Volvo workshop.

! IMPORTANT

Petrol-powered cars must always be refuelled with unleaded petrol so as not to damage the catalytic converter.

Refuelling with diesel

At low temperatures (–5 °C till –40 °C), a paraffin precipitate may form in the diesel fuel, which can lead to ignition problems. Make sure you use a special winter grade fuel during cold periods.



Emergency opening of the fuel filler flap

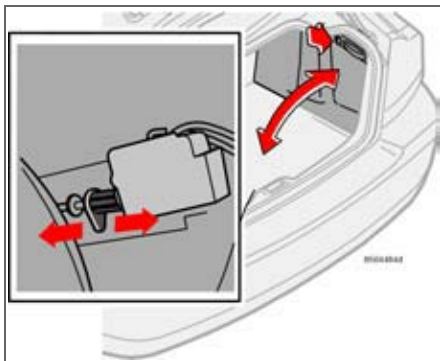

The fuel filler flap can be opened manually when necessary if it cannot be opened normally.

There is a detachable hatch on the right-hand panel of the cargo area. Undo this, insert your hand and locate the flap's electrical lock – location is approximately inside the rear edge of the fuel filler flap. Pull the lock plunger straight back.



WARNING

There are sharp edges behind the panel so move your hands slowly and carefully.



Starting the car

Before starting the engine

- Apply the parking brake.

Automatic gearbox

- Gear selector in position **P** or **N**.

Manual gearbox

Shift the gear lever into neutral and hold the clutch pedal fully depressed. This is particularly important in very cold conditions.

WARNING

Never remove the ignition key from the steering lock while driving or when the car is being towed. The steering lock could otherwise be activated, making it impossible to steer the car.

The ignition key must be in position **II** when the car is being towed.

NOTE

The idling speed can be noticeably higher than normal for certain engine types during cold starting. This is so that the emissions system can reach normal operating temperature as quickly as possible, which minimises exhaust emissions and protects the environment.

The master key blade must be fully extended (as illustrated on page 96) when starting the car. Otherwise there is a risk that the immobiliser function will prevent the car from starting.

Starting the engine

Petrol

Turn the ignition key to the start position. If the engine does not start within 5-10 seconds, release the key and repeat the start attempt.

Diesel

Turn the ignition key to the drive position. An indicator symbol in the combined instrument panel illuminates to show that engine preheating is underway, see page 43.

Turn the ignition key to the start position when the indicator symbol goes out.

Diesel particle filter (DPF)

Diesel cars are equipped with a particle filter, which results in more efficient emission control. The particles in the exhaust gases are collected in the filter during normal driving. So-called "regeneration" is started in order to burn away the particles and empty the filter. This requires the engine to have reached normal operating temperature.

Regeneration of the filter takes place automatically at an interval of approximately 300–900 km depending on driving conditions. Regeneration normally takes between 10 and 20 minutes. During this time fuel consumption may increase slightly.

Regeneration in cold weather

If the car is frequently driven short distances in cold weather then the engine does not reach normal operating temperature. This means that regeneration of the diesel particle filter does not take place and the filter is not emptied.

When the filter has become approximately 80 % full of particles, a yellow warning triangle illuminates on the instrument panel, and the message, **SOOT FILTER FULL** **SEE MANUAL** is shown on the instrument panel display.

Start regeneration of the filter by driving the car until the engine reaches normal operating temperature, preferably on a main road or motorway. The car should then be driven for approximately 20 minutes more. When regeneration is underway the engine power is reduced.

When regeneration is complete the warning message is cleared automatically.

Use the parking heater (option) in cold weather so that the engine reaches normal operating temperature more quickly.

IMPORTANT

If the filter fills up it may be incapable of functioning. Then it can be difficult to start the engine and there is a risk that the filter will have to be replaced.



Starting the car

Ignition keys and electronic immobiliser

The ignition key must not hang with other keys or metal objects on the same key ring. The electronic immobiliser could otherwise be activated accidentally. If this happens, – remove the excess keys and restart the car.

Never rev the engine hard straight after a cold start! If the engine does not start or misfires, contact a Volvo workshop.



WARNING

Never remove the ignition key from the steering wheel lock while driving or when the car is being towed! Never switch off the ignition (key to position 0) or remove the ignition key while the car is in motion. The steering wheel lock could be activated, making the car impossible to steer.

Ignition switch and steering lock

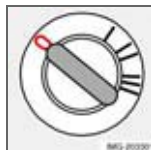

0 – Locked position

The steering wheel locks when the ignition key is removed.

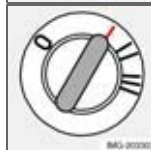

I – Radio position

Certain electrical components can be switched on. The engine's electrical system is not activated.



II – Driving position

The key position when driving. The car's entire electrical system is connected.



III – Start position

Starter motor. The starter motor is connected. Release the key once the engine has started. The key automatically springs back to the driving position. If the

key is hard to turn, the front wheels may be turned in such a way that there is tension in the steering wheel lock. In which case, turn the wheel back and forth to make it easier to turn the key.

Ensuring that the steering wheel is locked when you leave the car minimises the risk of theft.

Speed related power steering¹

If the car is equipped with speed related power steering this means that it is easier to steer at low speeds, which in turn facilitates parking etc.

As speed is increased the steering force is adapted to give the driver enhanced sensitivity.

¹ Option



Manual gearbox

Gear positions, five-speed



Depress the clutch pedal fully with each gear change. Remove your foot from the clutch pedal between gear changes. Follow the appropriate shifting pattern.

For the best possible fuel economy, use the highest gear possible as often as possible.

Reverse gear inhibitor

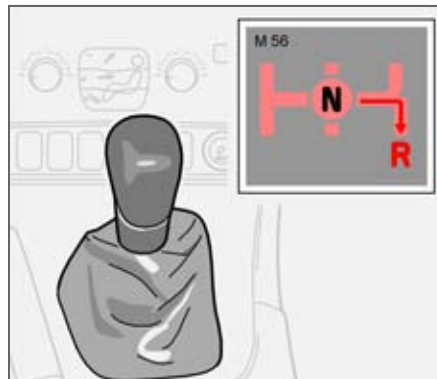

Only engage reverse gear when the car is stationary.

To put the car in reverse, the gear lever must first be moved to neutral (between 3rd and 4th gear). Thus, reverse cannot be directly selected from 5th gear due to the reverse gear inhibitor.

Gear positions, six-speed



Depress the clutch pedal fully with each gear change. Remove your foot from the clutch pedal between gear changes. Follow the appropriate shifting pattern.

For the best possible fuel economy, use the highest gear possible as often as possible.



Automatic gearbox

Cold start

When starting in low temperatures, the gear changes can sometimes feel hard. This is due to the gearbox oil's viscosity at low temperatures. To minimise engine emissions, the gearbox shifts up later than normal when the engine is started at low temperatures.

Turbo engine

When the engine is cold, the transmission shifts gears at higher revs. This allows the catalytic converter to reach normal operating temperature more quickly, with less exhaust emissions.

Adaptive system

The gearbox is controlled by what is known as an adaptive system. The system continually monitors how the gearbox is behaving and senses every gear change for optimum change quality.

Lock-up function

The gears have a lock-up function (locked gears), which gives better engine braking and lower fuel consumption.

Safety systems

Cars with an automatic gearbox have special safety systems:

Keylock

To remove the ignition key, the gear selector must be in the **P** position. The key is locked in all other positions.

Parking position (P)

Stationary car with engine running:

- Hold your foot on the brake pedal when moving the gear selector to another position.

Electric gear inhibitor – Shiftlock

Parking position (P position)

To be able to move the gear selector from the **P** position to other gear positions, the ignition key must be in position **I** or **II** and the brake pedal must be depressed.

Neutral position (N position)

The brake pedal must be depressed to move the gear selector from position **N** to other gear positions when the ignition key is in position **I** or **II**.

Mechanical gear selector inhibitor

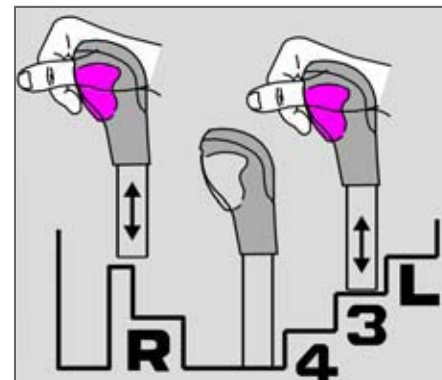

The gear selector can be moved freely between **N** and **D**. Other positions are locked with a latch that is released with the inhibitor button on the gear selector.

Press the inhibitor button to move the lever forward or back between the different gear positions.



Automatic gearbox

Manual positions

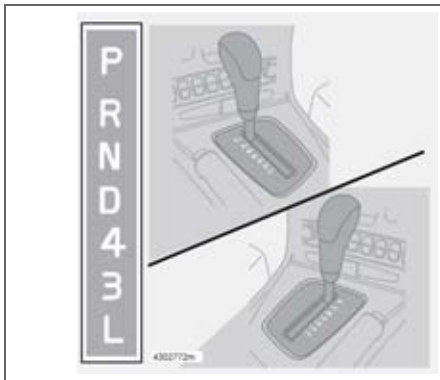

P – Park

Select this position when you wish to start the engine or park the car.

The car should be stationary when you select **P**!

In **P** the gearbox is mechanically locked. Always apply the parking brake when parking the car.

R – Reverse

The car should be stationary when you select **R**.

N – Neutral

N is the neutral position. No gear is engaged and the engine can be started. Apply the parking brake when the car is stationary with the gear selector in position **N**.

D – Drive

D is the normal driving position. The car automatically shifts between the different gears of the gearbox based on the level of acceleration and speed. The car should be stationary when selecting **D** from position **R**.

4 – Low gear

Up and downshifts between 1st, 2nd, 3rd and 4th are automatic. There is no upshift to 5th gear.

Position **4** can be used:

- for mountain driving
- when driving with a trailer
- to increase engine braking

3 – Low gear

Up and downshifts between 1 st, 2 nd, and 3 rd are automatic. There is no upshift to 4 th gear.

Position **3** can be used:

- for mountain driving

- when driving with a trailer
- to increase engine braking

L – Low gear

Select **L** if you wish to drive in 1st or 2nd. Position **L** gives the best engine braking for mountain driving, etc.



Automatic gearbox

Geartronic

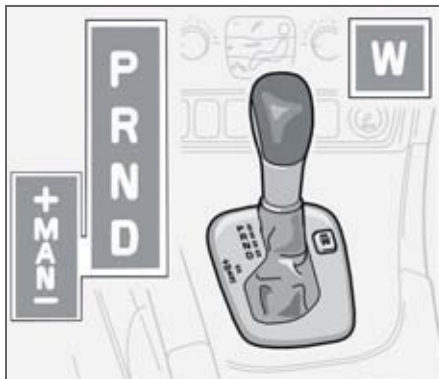

Manual positions

To move from the automatic driving position **D** to a manual position, move the gear selector to the left.

To go from position **MAN** to the automatic driving position **D**, move the selector to the right to position **D**.

W - Winter mode

When the winter programme is selected the gearbox starts in 3rd gear in order to reduce the risk of wheel spin on slippery road surfaces, see also the heading **W - Winter**.

W – Winter



The **W** button by the gear selector engages and disengages the winter programme **W**. The symbol **W** is shown in the combined instrument panel when the winter programme is activated.

The winter programme starts the gearbox in 3rd gear to make it easier to pull off on slippery roads. When the programme is engaged, lower gears are activated only by kick-down.

The **W** programme can only be selected in position **D**.

Manual positions, Geartronic

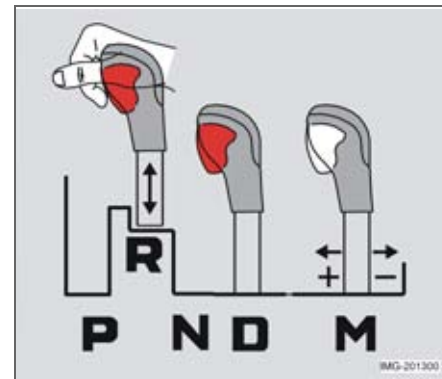

To move from the automatic driving position **D** to a manual position, move the gear selector to the left. To go from the **MAN** position to the automatic driving position, move the selector to position **D**.

While driving

The manual gearshift mode can be selected at any time while driving. The engaged gear is locked until you choose another gear. The car will only shift down automatically if you slow down to a very slow speed.

If the gear selector is moved to – (minus) the car changes down a gear and engine brakes at the same time. If the gear selector is moved to + (plus) the car changes up a gear.



Automatic gearbox

Kick-down

When the accelerator is pressed all the way to the floor, beyond the position normally regarded as full acceleration, a lower gear is immediately engaged. This is known as kick-down.

When maximum speed for this gear is reached, or if the accelerator is released from the kick-down position, the gearbox automatically changes up.

Kick-down is used when maximum acceleration is needed, such as for overtaking.

To prevent overrevving, the gearbox control program has a protective downshift inhibitor.

The kick-down function¹ cannot be used in the manual positions. Return to automatic position **D**.

¹ Applies to Geartronic only.

**All-wheel drive – AWD****All-wheel drive is always engaged**

All-wheel drive means that all four road wheels are driven at the same time. Power is automatically distributed between front and rear wheels. An electronically controlled clutch system distributes the power to the pair of wheels that grips best. This provides the best traction and prevents wheel spin.

Under normal driving conditions, the majority of power is transmitted to the front wheels.

All-wheel drive improves driving safety in rain, snow and icy conditions.



Brake system

Brake servo

If the car is rolling or is being towed with the engine turned off, the brake pedal must be pressed about five times harder than when the engine is running. If the brake pedal is pressed when the engine is started, you will feel the pedal drop. This is normal and due to the brake servo becoming active. This may be more noticeable if the car has emergency brake assistance (EBA).

WARNING

The brake servo only works when the engine is running.

NOTE

If braking with the engine switched off, press the brake pedal sharply once, not repeatedly.

Brake circuits



This symbol illuminates if a brake circuit is not working.

If a fault should occur in one of the circuits, it is still possible to brake the car. The brake pedal will travel further and may feel softer than normal. Harder

pressure on the pedal is needed to produce the normal braking effect.

Dampness can affect braking characteristics

Brake components become wet when the car is driven in heavy rain, through pools of water or when the car is washed. This may alter brake pad friction characteristics so that there is a delay before braking effect is noticed.

Press the brake pedal lightly from time to time if driving for long stretches in rain or slushy snow, as well as after setting off in very damp or cold weather. This warms up the braking surfaces and dries off any water. It is also recommended to do this before parking the car for a long period in such weather conditions.

If the brakes are used heavily

When driving in the Alps or other roads with similar characteristics, the car's brakes are heavily loaded even if the brake pedal is not being depressed especially hard.

Because speed is often low, the brakes are not cooled as effectively as when driving on flat roads at higher speed.

So as not to overload the brakes, shift down when driving downhill instead of using the foot brake. Use the same gear driving downhill as you would use driving uphill. This method uses engine braking more efficiently and requires the foot brake for only brief periods.

Bear in mind that driving with a trailer puts an additional load on the car's brakes.

Anti-lock braking system (ABS)



The ABS system (Anti-lock Braking System) is designed so that the wheels do not lock when braking.

This retains the best possible steering response when braking. This improves your ability to swerve to avoid obstacles. The ABS system does not increase your total braking capacity. However, as the driver you have increased ability to steer and thus better control over the car, which in turn increases safety.

After the engine has started and reached a speed of about 20 km/h, a short self-test can be both heard and felt. When the ABS system functions, you can hear and feel pulses in the brake pedal. This is completely normal.

**Brake system**** NOTE**

You must depress the brake pedal fully to take maximum advantage of the ABS system.

Do not release the pedal when you hear and feel the ABS pulses.

Practice braking with the ABS system at a suitable location such as a skid pan to practice skidding.

The ABS symbol illuminates:

- for approximately two seconds during the system test when the car is started.
- if the ABS system has shut down due to a fault.

 WARNING

If the BRAKE and ABS warning symbols are illuminated at the same time, a fault may have occurred in the brake system. If the level in the brake fluid reservoir is normal, drive carefully to the nearest authorised Volvo workshop to have the brake system checked.

If the brake fluid is under the MIN level in the brake fluid reservoir, do not drive further before topping up the brake fluid.

The reason for the loss of brake fluid must be investigated.

Electronic brake force distribution system – EBD

The Electronic Brakeforce Distribution system (EBD) is an integrated part of the ABS system. The EBD system controls the brake force to the rear wheels so that the best possible braking force is always available. Pulses will be heard and felt through the brake pedal when the system regulates brake force.

Emergency Brake Assistance – EBA

The Emergency Brake Assistance function (EBA) is integrated in the DSTC system and is designed to provide immediate maximum brake force whenever rapid braking is necessary. The system detects the need for heavier braking by registering how quickly the brake pedal is applied.

The EBA function is active at all speeds. For safety reasons, it cannot be switched off.

When the EBA function is activated, the brake pedal sinks while maximum braking force is applied. Continue braking without releasing the brake pedal. The EBA function disengages when the pressure on the brake pedal is released.

 NOTE

When EBA is activated the brake pedal lowers slightly more than usual, depress (hold) the brake pedal as long as necessary. If the brake pedal is released then all braking ceases.



Stability and traction control system, option

General

The Dynamic Stability and Traction Control system (STC/DSTC) improves the car's traction and helps the driver to avoid skidding.

A pulsing sound may be noticed during braking or acceleration when the system is in action. The car may accelerate more slowly than expected.

The car is equipped with either STC or DSTC depending on market. The table shows the integral functions of the respective systems.

| Function/system | STC | DSTC ¹ |
|-------------------------|-----|-------------------|
| Active Yaw Control | | X |
| Spin Control | X | X |
| Traction control system | X | X |

¹Option in certain markets.

Active Yaw Control

The function limits the driving and brake force of the wheels individually in order to stabilise the car.

Spin Control

The function prevents the driving wheels from spinning against the road surface during acceleration.

Traction control system

The function is active at low speed and transfers power from the driving wheel that is spinning to the one that is not.

Reduced operation

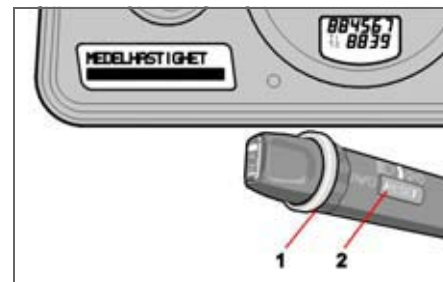

System operation during skidding and acceleration can be partially deactivated.

Operation during skidding is delayed and so allows more skidding which provides greater freedom for dynamic driving.

Traction in deep snow or sand is improved as acceleration is no longer limited.

Operation

- Turn the thumbwheel (1) until the STC/DSTC menu is shown.

DSTC ON means that the system function is unchanged.

DSTC SPIN CONTROL OFF means that system operation is reduced.

- Press and hold **RESET** (2) until the STC/DSTC menu is changed.



Stability and traction control system, option

At the same time the symbol  illuminates as a reminder that the system has been reduced. The system remains reduced until the engine is next started.

WARNING

Suppressing system function may alter the driving characteristics of the car.

NOTE

DSTC ON is shown for several seconds in the display each time the engine is started.

Messages in the display

TRACTION CONTROL TEMPORARILY OFF means that the system has been temporarily reduced due to excessive brake disc temperature.

The function is reactivated automatically when the brakes have cooled.

ANTI-SKID SERVICE REQUIRED means that the system has been disabled due to a fault.

- Stop the car in a safe place and turn off the engine.

If the message remains when the engine is restarted, drive to an authorised Volvo workshop.

Symbols in the combined instrument panel



Symbol for STC/DSTC

The symbol has different meanings depending on how it is shown.

The symbol illuminates and goes out again after approx. two seconds

- Indicates system check when the engine is started.

The symbol flashes

- Indicates that the system is operating.

The symbol illuminates and stays lit
ANTI-SKID SERVICE REQUIRED is shown in the display at the same time.

Fault indicator in STC/DSTC system:

- Stop the car in a safe place and turn off the engine.
- Restart the car.
- If the warning symbol goes out, the fault was temporary and it is not necessary to visit a workshop.
- If the warning symbol remains lit, drive to an authorised Volvo workshop to have the system checked.

The symbol illuminates and stays lit
DSTC SPIN CONTROL OFF is shown in the display at the same time.

- Reminds that the STC/DSTC system has been reduced.



Symbol for Warning

The symbol illuminates with a constant yellow glow.

TRACTION CONTROL TEMPORARILY OFF is shown in the display at the same time.

- Indicates that the system has been temporarily reduced due to excessive brake temperature.
- Automatic reactivation of the function takes place when the brake temperature has returned to normal.

WARNING

Under normal driving conditions, the STC/DSTC system improves the car's road safety, but this should not be taken as a reason to increase speed.

Always follow the usual precautions for safe cornering and driving on slippery road surfaces.



Active chassis – FOUR-C

Active chassis – FOUR-C¹



Switch in centre console for FOUR-C

The car is equipped with an extremely advanced active chassis system – Continuously Controlled Chassis

Concept – that is regulated electronically. The functions of the system are based on a number of sensors that continually monitor the car's movements and reactions, such as vertical and lateral acceleration, vehicle speed and wheel movements.

The FOUR-C control unit analyses data from the sensors and performs the necessary shock absorber setting adjustments up to 500 times per second. This results in extremely fast and accurate individual shock absorber control, which contributes to variations in chassis characteristics.

Chassis characteristics can be modified at any time while driving, when the nature of the road changes or when you desire a change in driving style. This change occurs in a matter of milliseconds.

Comfort

Comfort mode adjusts the chassis setting so that the body is insulated from uneven sections of the road surface, which allows for better "glide". Shock absorption is softer and body movements are minimal. This setting is recommended for long-distance driving or driving on slippery road surfaces.

When the ignition is switched off in **Comfort** setting, the chassis will resume the same mode when the car is re-started.

Sport

In **Sport** mode, steering responses are quicker than in **Comfort** mode. Damping is harder and the body follows the road surface to minimise rolling during quick cornering. The car feels sportier.

When the ignition is switched off in **Sport** setting, the chassis will resume the same mode when the car is re-started.

¹ Option in certain markets.



Parking assistance

General¹

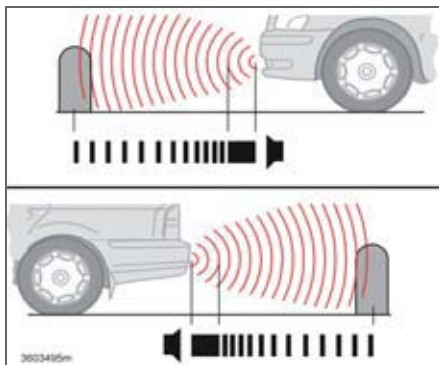

Parking assistance front and rear.

Parking assistance is used as an aid to parking. A signal indicates the distance to a detected object.

WARNING

Parking assistance does not relinquish the driver's own responsibility during parking. The sensors have blind spots where objects cannot be detected. Be aware of children and animals near the car.

Variants

Parking assistance is available in two variants:

- Rear only
- Both front and rear.

Function

The system is switched on automatically when the car is started at which point the lamp in the switch for parking assistance illuminates. The display shows the text message **PARK ASSIST ACTIVE** if reverse gear is engaged or if the front sensors detect an object.

Parking assistance is active at speeds below 15 km/h. The system is deactivated at higher speeds. The system is reactivated when the speed falls below 10 km/h again.

The frequency of the signal increases as you come closer to an object in front of or behind the car. If the volume of another sound source from the audio system is high, this is automatically muted.

The tone becomes constant at a distance of about 30 cm. If there are objects within this distance behind or in front of the car, the signal alternates between left and right-hand speakers.

Rear parking assistance

The distance covered to the rear of the car is about 1.5 m. Rear parking assistance is activated when reverse gear is engaged. The signal comes from the rear loudspeakers.

The system must be deactivated when reversing with a trailer, or bike carrier on the towbar or similar. Otherwise the trailer or bike carrier would trigger the sensors.

Rear parking assistance is deactivated automatically when towing a trailer if a Volvo genuine trailer cable is used.

Front parking assistance

The distance covered to the front of the car is about 0.8 metres. The signal comes from the front loudspeakers.

Front parking assistance cannot be combined with extra lights because the sensors are affected by the extra lights.

¹ Depending on the market, the Parking assistance system may be either Standard, Option or Accessory.



Parking assistance

Fault indicator



If the yellow warning symbol illuminates and the display shows **PARK ASSIST SERVICE REQUIRED** then parking assistance is disengaged.

! IMPORTANT

In certain conditions the parking assistance system may produce incorrect warning signals that are caused by external sound sources that emit the same ultrasonic frequencies that the system works with.

Examples of such sources include horns, wet tyres on asphalt, pneumatic brakes and exhaust noises from motorcycles etc.

Off/On

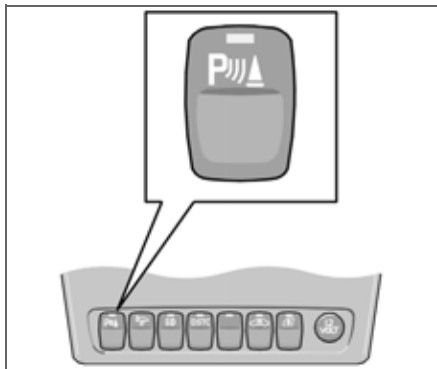

Button position in the row may vary.

Parking assistance can be deactivated with the button in the switch panel. The lamp in the switch goes out. Parking assistance is switched on again with the switch and the lamp illuminates.

Cleaning the sensors

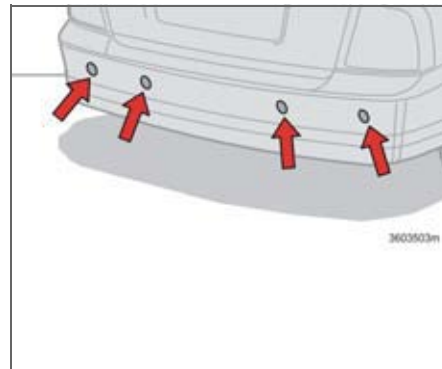

Parking assistance sensors.

The sensors must be cleaned regularly to ensure that they work properly. Clean them with water and car shampoo.

i NOTE

Dirt, ice and snow covering the sensors may cause incorrect warning signals.



Towing and recovery

Do not tow the car to bump start it

If you bump start a car with manual gearbox, the catalytic converter may be damaged. Cars with automatic gearbox cannot be bump started. Use a booster battery if the battery is flat.

If the car must be towed

- Unlock the steering wheel lock so that the car can be steered.
- Keep in mind the highest legally permissible speed.
- Bear in mind that the brake and power steering servos do not function when the engine is off. Approx. five times more pressure must be exerted on the brake pedal and steering requires much more force than usual.
- Drive gently.
- Keep the towline taut in order to avoid unnecessary jerking.

For automatic gearboxes

- The gear selector should be in position **N**.
- The maximum permissible speed when towing a car with automatic gearbox is 80 km/h.
- Longest permitted distance: 80 km.
- The engine cannot be towed to start (bump started). See "Jump starting" on the next page.

Towing eye, rear

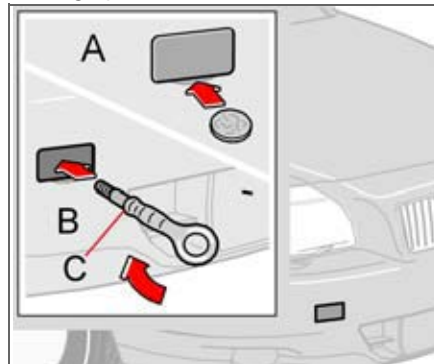

Towing eye, front

The towing eye is located in the tool kit in the cargo area. You must screw the towing eye into place before towing. The sockets and covers for the towing eye are located on the right-hand side of each bumper.

To fit the towing eye

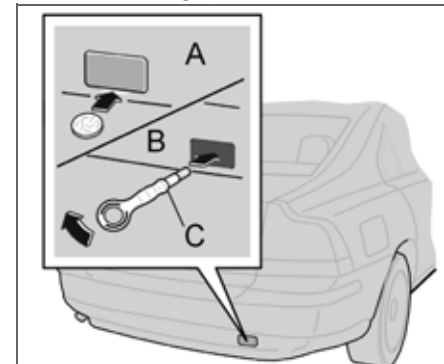

Towing eye, rear

- Release the (A) cover¹ by carefully prizing in the groove with a coin for example.
- Screw the (B) towing eye securely into place up to the flange (C). You can use a wheel wrench.

After use, unscrew the towing eye and refit the cover.

To screw in the rear towing eye, you must first remove a plastic bolt from the bracket for the rear towing eye. Use the wheel wrench from the tool kit to unscrew the plastic bolt. Refit the plastic bolt after use.

¹ The method of opening the cover may vary.



Towing and recovery

NOTE

The towing eye cannot be fitted in the rear bracket on cars with towbar. In which case, secure the tow rope in the towbar. For this reason, it is advisable to always store the detachable towbar in the car.

Recovery

The towing eye may only be used for towing on roads, not for recovery after driving into a ditch or the like. Professional help should be called for recovery.



Start assistance

Starting with a donor battery

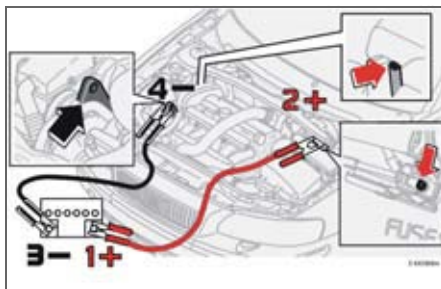

If for some reason the battery in your car is discharged, you can "borrow" current from a spare battery or another car's battery to start the engine. Always check that the clamps are fastened properly to prevent sparking during the start attempt.

To avoid the risk of explosion, we recommend you do exactly as follows.

- Turn the ignition key to position **0**.
- Ensure that the donor battery is 12 volt.
- If the booster battery is in another car, stop the engine of that car and make sure the cars are not touching.
- Connect the red cable between the booster battery positive terminal (1+) and the red connection in the engine compartment (2+). Attach the clamp to the contact

point located beneath a small black cover with a plus sign which is integrated in the fuse box cover.

- Connect one clamp of the black cable to the negative terminal of the booster battery (3-).
- Connect the other clamp of the black cable to the lifting eye on the car's engine (4-).
- Start the engine of the "booster car". Let the engine run a few minutes at a speed slightly higher than idle, 1500 rpm.
- Start the engine of the car with the flat battery.
- Remove the clamps in reverse order.

i NOTE

Do not remove the clamps during the start attempt (risk of spark build-up).

! WARNING

The battery can generate oxyhydrogen gas, which is highly explosive. One spark, which can be generated if you connect the jump leads incorrectly, is sufficient to make the battery explode.

The battery contains sulphuric acid, which can cause serious burns. If the acid comes into contact with eyes, skin or clothing, flush with large quantities of water. If acid splashes into the eyes, seek medical attention immediately.



Driving with a trailer

General

The towing bracket on the car must be approved. Your Volvo dealer can advise you as to which towing bracket to use.

- Distribute the load on the trailer so that the weight on the towing bracket follows the specified maximum towball load.
- Increase tyre pressure so that it corresponds to the pressure for full load. See the tyre pressure table!
- Clean the towing bracket regularly and grease the towball¹ and all moving parts to prevent unnecessary wear.
- Do not drive with a heavy trailer when your car is brand new! Wait until it has driven at least 1000 km.
- The brakes are loaded much more than usual on long and steep downhill slopes. Downshift to a lower gear and adjust your speed.
- If the car is driven with a heavy load in a hot climate, the engine and gearbox may overheat. The temperature gauge in the combined instrument panel goes into the red zone when the car overheats. Stop and let the engine idle a few minutes.
- If the car overheats, the air conditioning system can be temporarily switched off.

¹ Does not apply to ball hitch with vibration damper.

- The gearbox reacts with a built-in protection function if the car overheats. See the message in the display!
- The engine is loaded more heavily than usual when driving with a trailer.
- For reasons of safety, you should not drive faster than 80 km/h, even if the laws of certain countries permit higher speeds.
- If you park with a trailer, apply the parking brake first, and then move the gear selector into position **P** (automatic gearbox) or select a gear (manual gearbox). If you park on a steep hill, put chocks under the wheels.
- Avoid driving on inclines exceeding 12 % if the trailer weight exceeds 1200 kg. Do not drive with a trailer at all on inclines exceeding 15 %.

Trailer weights

See page 250 for permitted trailer weights.



NOTE

The stated maximum permitted trailer weights are those permitted by Volvo. National vehicle regulations can further limit trailer weights and speeds. Towbars can be certified for higher towing weights than the car can actually tow.



WARNING

Follow the stated recommendations for trailer weights. Otherwise, the rig may be difficult to control during evasive manoeuvres and braking.



Driving with trailer – automatic gearbox

- When parking on hills, apply the parking brake before moving the gear selector to **P**. When starting on a hill, first put the gear selector in drive and then release the parking brake.
- Select a low gear in the gearbox when driving on steep inclines or when driving slowly. This prevents the gearbox from upshifting if you have an automatic gearbox. The gearbox oil will be cooler.
- If you have a Geartronic gearbox, do not use a higher manual gear than the engine can "handle". It is not always economical to drive in high gears.

NOTE

Some models require an oil cooler for the automatic gearbox when driving with a trailer. Check with your nearest Volvo dealer as to what applies to your car if you have a retrofitted towbar.

Levelling

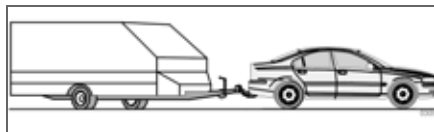

If your car is equipped with automatic levelling, the rear suspension always retains the correct ride height regardless of load. When the car is stationary, the rear suspension sinks. This is completely normal. When starting with a load, the level is pumped up after a certain distance.



Towing equipment

Towbars

The towball must be cleaned and greased regularly. If a towball hitch with vibration damper is used, it is not necessary to grease the towball.

If the car is equipped with a detachable towbar, the towball installation instructions must be followed carefully, see page 136.

WARNING

Be sure to attach the trailer's safety cable to the correct place.

WARNING

If the car is fitted with a Volvo detachable towbar:

Follow the assembly instructions for the towball section carefully.

The towball section must be locked with the key before setting off.

Check that the indicator window shows green.

NOTE

Always remove the towball section after use. Keep it in the cargo area.

Trailer cable

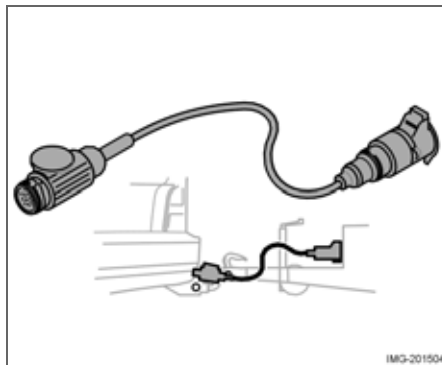

An adapter is required if the car's towbar has 13 pin electrics and the trailer has 7 pin electrics. Use an adapter cable approved by Volvo. Make sure the cable does not drag on the ground.



Towing equipment

Specifications

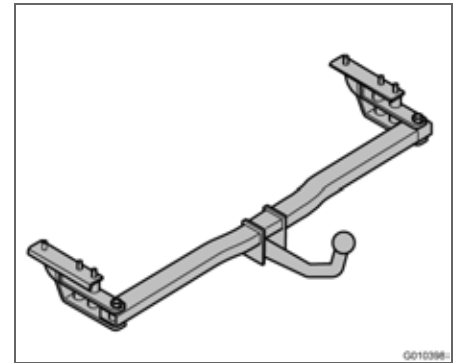
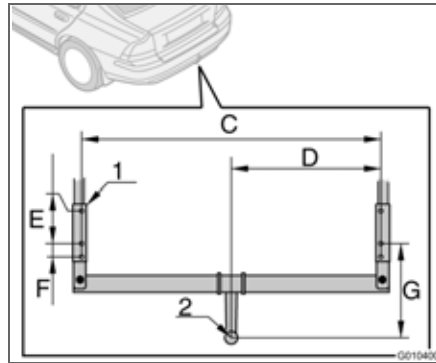
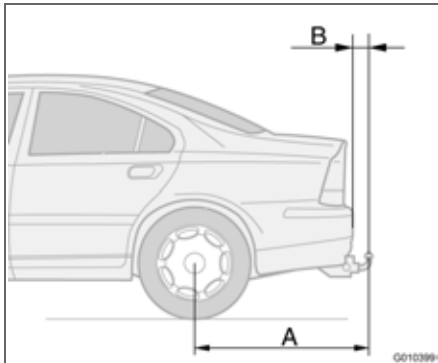

Dimensions for mounting points (mm)

| | A | B | C | D | E | F | G |
|--------------------------------|-------------|-----|------|-----|-----|----|-----|
| Fixed towbar standard | 1058 | 83 | 1083 | 542 | 122 | 50 | 305 |
| Fixed towbar with Nivomat | | 91 | | | | | |
| Detachable towbar standard | 1069 | 94 | | | | | 316 |
| Detachable towbar with Nivomat | | 100 | | | | | |
| 1 | Side member | | | | | | |
| 2 | Ball centre | | | | | | |



Detachable towbar

Fitting the towball

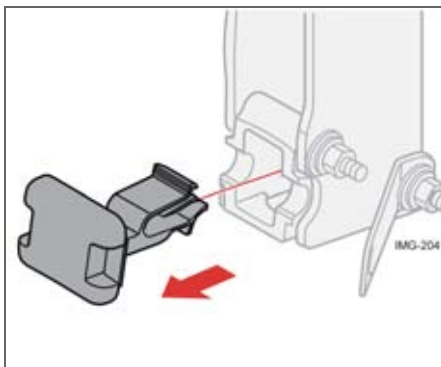

- Remove the guard plug.

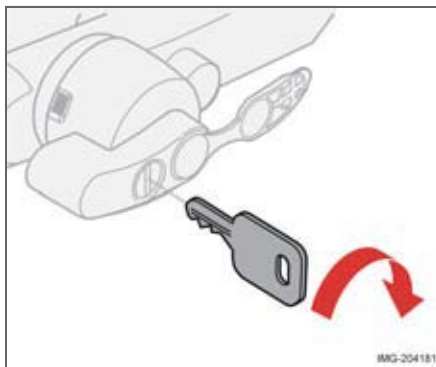

- Ensure that the mechanism is in the unlocked position by turning the key clockwise.

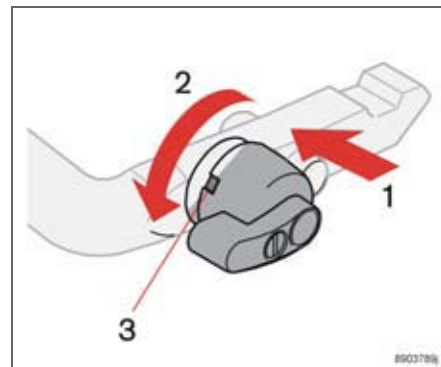

- Check that the indicator window (3) shows red. If the window does not show red, press in (1) and turn the locking wheel anticlockwise (2) until you hear a click.

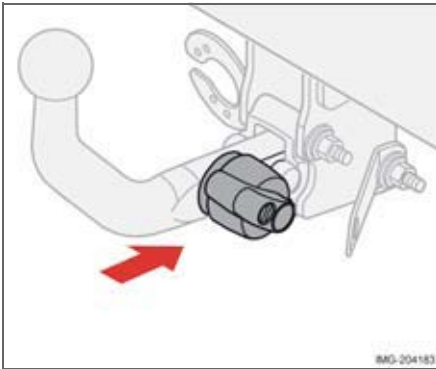
**Detachable towbar**

- Insert the towball section until you hear a click.

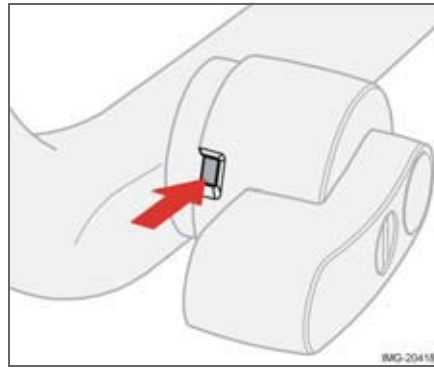

- Check that the indicator window shows green.

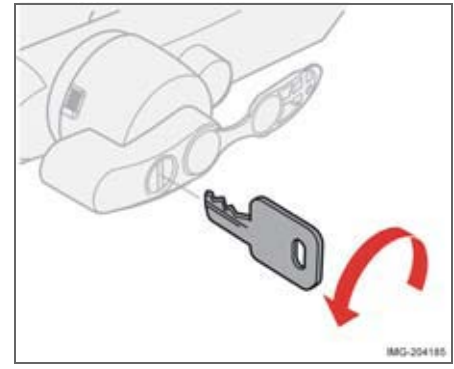

- Turn the key anticlockwise to the locked position. Remove the key from the lock.



Detachable towbar



i NOTE

Check that the towball section is secure by pulling it up, down and back. If the towball section is not fitted correctly then it must be removed and refitted in accordance with the previous steps.

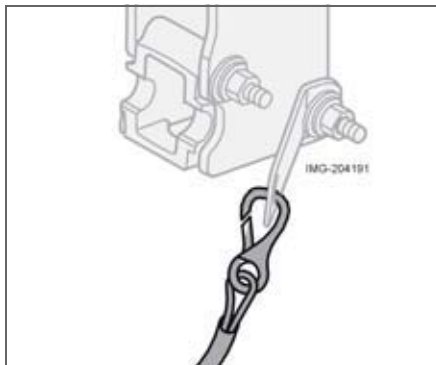

i NOTE

The trailer's safety cable must be attached to the attachment on the towbar.

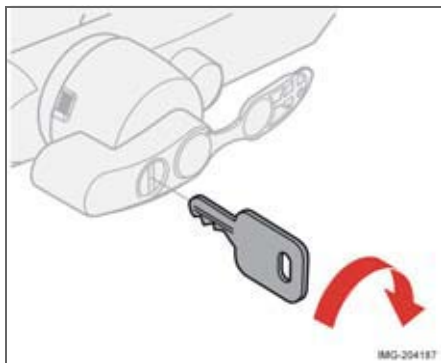
**Detachable towbar****Removing the towball**

- Insert the key and turn it clockwise to the unlocked position.

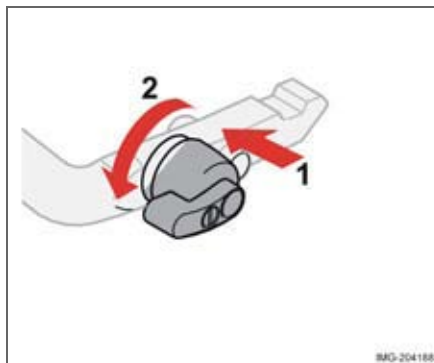

- Push in the locking wheel (1) and turn it anticlockwise (2) until you hear a click.

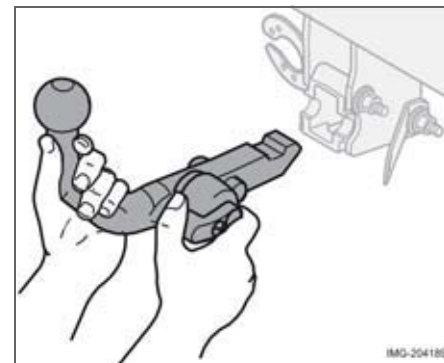

- Turn the locking wheel down fully, until it comes to a stop. Hold it in this position while pulling the towball rearward and upward.



Detachable towbar

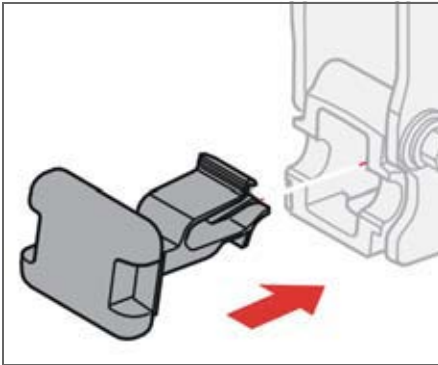

- Insert the guard plug.



Load on the roof

General

The load capacity is affected by extra accessories mounted on the car, such as a towbar, load carriers, space box, the passengers' combined weight etc. as well as towball load. The load capacity of the car is reduced by the number of passengers and their weight. For information on permitted weights, see page 250.

WARNING

The car's driving characteristics change depending on how heavily it is loaded and how the load is distributed.

Using load carriers (accessory)

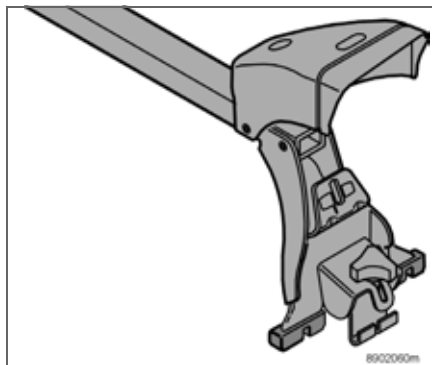

To avoid damaging your car and to achieve the best level of safety when driving, we recommend that you only use load carriers that Volvo has specially designed for your car.

- Check periodically that the load carriers and load are properly secured. Lash the load securely with retaining straps.
- Distribute the load evenly over the load carriers. Do not load lopsidedly. Place the heaviest items at the bottom.
- Remember that the car's centre of gravity and driving characteristics change if you have a load on the roof.

- Keep in mind that the car's wind resistance and fuel consumption increase in proportion to the size of the load.
- Drive gently. Avoid quick accelerations, heavy braking and taking curves hard.
- Remove the load carrier when it is not in use. This reduces wind resistance and fuel consumption.

WARNING

Load no more than 100 kg on the roof, including the load carriers and any space box.

The car's centre of gravity and driving characteristics are altered by roof loads.



Load on the roof

Fitting load carriers

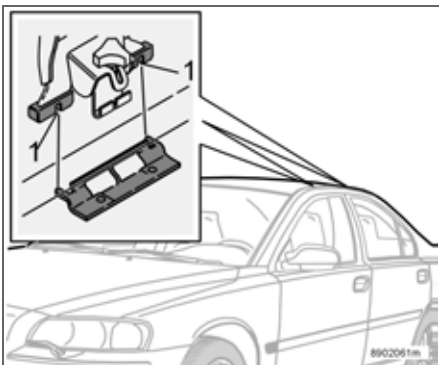

- Make sure that the load carrier is fitted in the right direction (see the marking on the decal under the cover).
- Fit the guide pins into the guide holes (1).
- Carefully lower the bracket on the other side to the roof.
- Screw the knob up a bit.
- Press the knob against the roof bracket and catch the hook in the roof bracket under the roof rail.
- Screw the load carrier in place.
- Fit the guide pins of the other brackets into the guide holes.
- Screw the load carrier in place.

- Check that the hook is properly secured in the roof bracket.
- Tighten the knobs alternately until the carrier feels secure.
- Replace the cover.
- Check that the roof rack is properly secured.



NOTE

Check the knobs regularly to see that they are properly tightened.



Adjusting headlamp pattern

Correct light pattern for right or left-hand traffic

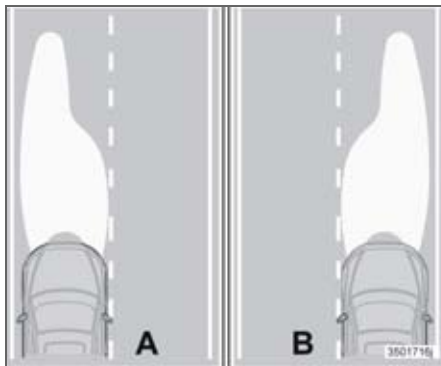

A. Headlamp pattern for left-hand traffic.

B. Headlamp pattern for right-hand traffic.

So as not to dazzle oncoming drivers, the headlamp beam pattern can be altered by masking the headlamps. The quality of the beam pattern may not be as good.

Headlamp masking

Copy the templates and transfer the pattern to a self-adhesive, waterproof material such as opaque tape or the like.

The mask is positioned using the dot (5) in the headlamp lens as a reference point. The reference measurement (X) indicates the dis-

tance from the dot (5) to the corner of the mask, marked with an arrow.

After copying the templates located on the next page, check the measurements so that the reference measurements cover enough of the beam pattern.

Adjusting headlamp pattern for Active Bi-Xenon Lights ABL see page 50.



Adjusting headlamp pattern

Halogen headlamps

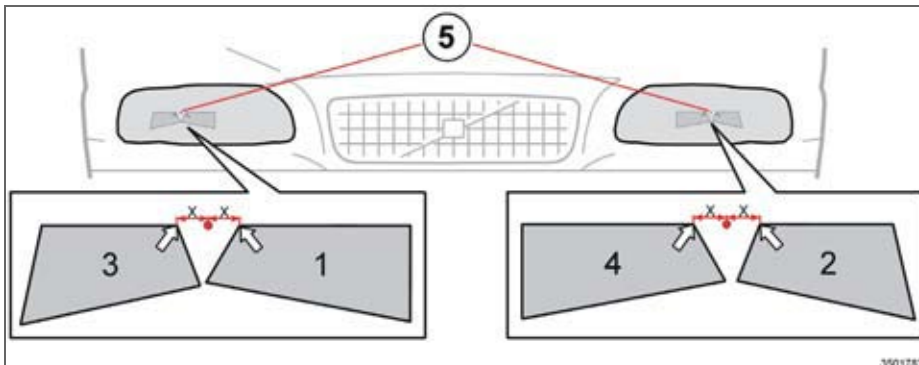

Location of halogen headlamp masks, 1 and 2 = LHD variant, 3 and 4 = RHD variant

LHD variant

Copy templates 1 and 2. Check the measurements to ensure they are correct. Transfer the template to a self-adhesive, waterproof material and cut it out.

Reference measurements

Template 1. (3) = 70 mm, (4) = 40 mm

Distance to dot in headlamp lens:
(5) = 13 mm.

Template 2. (6) = 55 mm, (7) = 40 mm

Distance to dot in headlamp lens:
(8) = 18 mm.

RHD variant

Copy templates 3 and 4. Check the measurements to ensure they are correct. Transfer the template to a self-adhesive, waterproof material and cut it out.

Reference measurements

Template 3. (1) = 55 mm, (2) = 41 mm

Distance to dot in headlamp lens:
(5) = 17 mm.

Template 4. (6) = 70 mm, (7) = 39 mm

Distance to dot in headlamp lens:
(8) = 14 mm.



Adjusting headlamp pattern

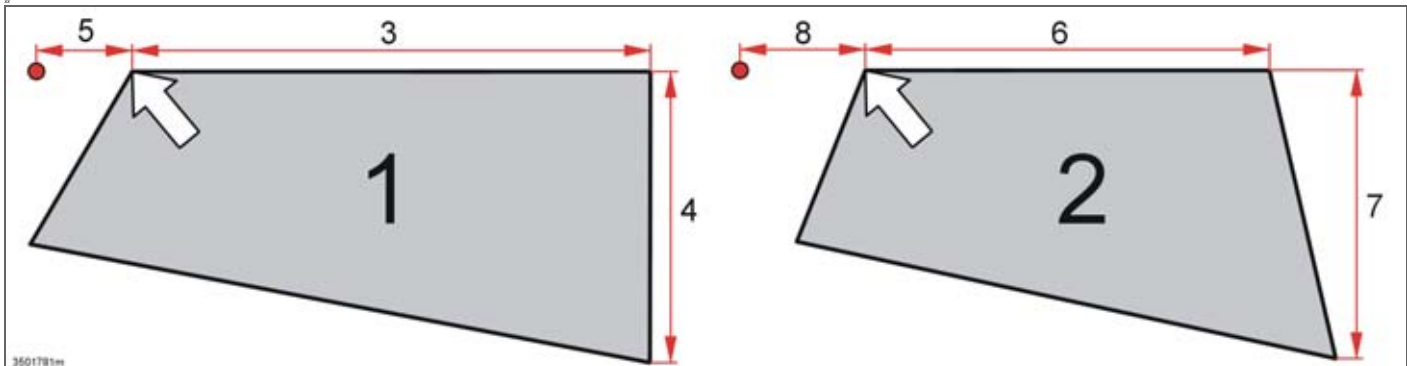

Masking templates for halogen headlamps, LHD variant

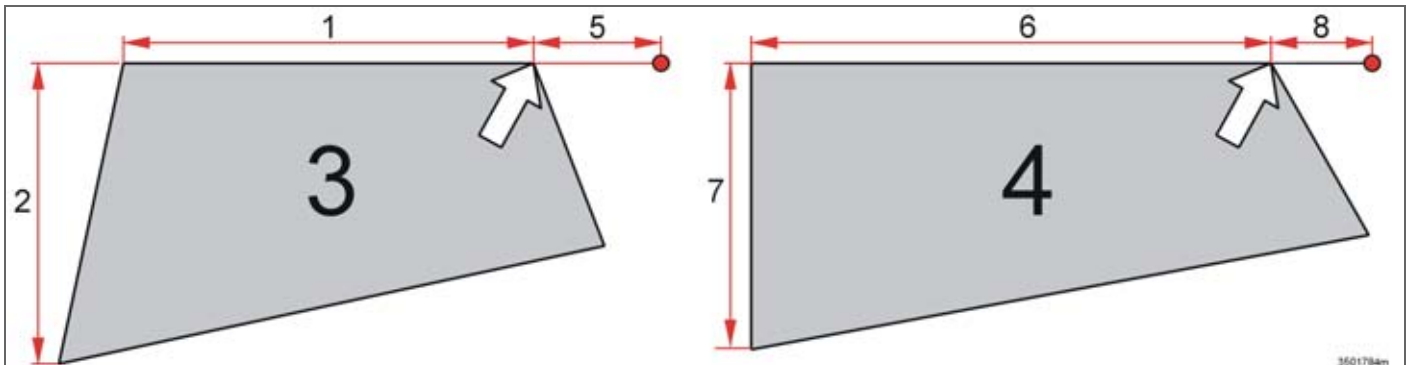

Masking templates for halogen headlamps, RHD variant



Adjusting headlamp pattern

Bi-Xenon headlamps

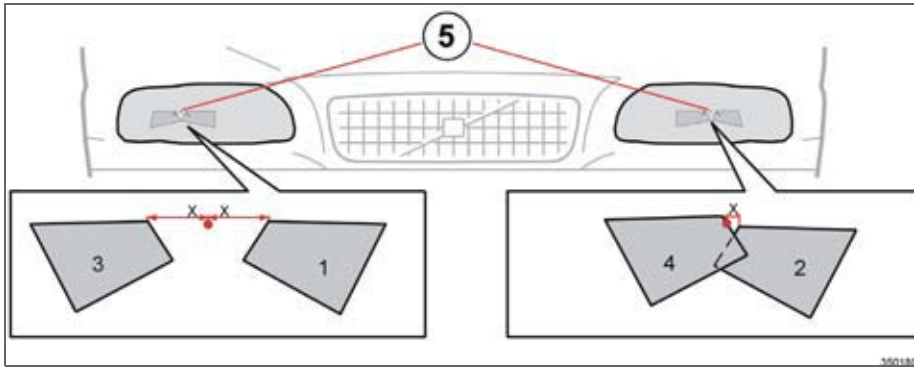

Location of Bi-Xenon headlamp masks, 1 and 2 = LHD variant, 3 and 4 = RHD variant

**Adjusting headlamp pattern****LHD variant**

Copy templates 1 and 2. Check the measurements to ensure they are correct. Transfer the template to a self-adhesive, waterproof material and cut it out.

Reference measurements

Template 1. (3) = 56 mm, (4) = 43 mm

Distance to dot in headlamp lens:
(5) = 29 mm.

Template 2. (6) = 56 mm, (7) = 42 mm

Distance to dot in headlamp lens:
(8) = 6 mm.

RHD variant

Copy templates 3 and 4. Check the measurements to ensure they are correct. Transfer the template to a self-adhesive, waterproof material and cut it out.

Reference measurements

Template 3. (1) = 56 mm, (2) = 42 mm

Distance to dot in headlamp lens:
(5) = 29 mm.

Template 4. (6) = 56 mm, (7) = 41 mm

Distance to dot in headlamp lens:
(8) = 0 mm.



Adjusting headlamp pattern

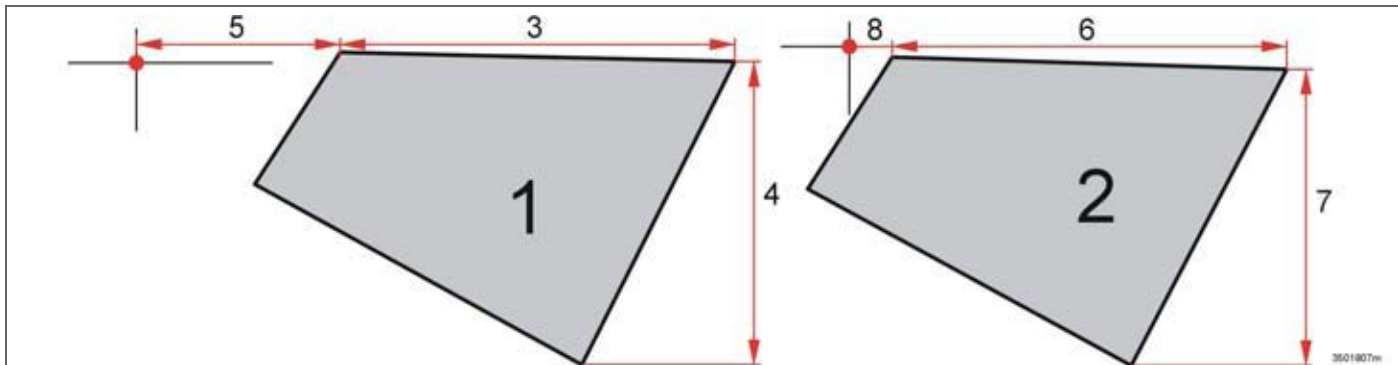

Masking templates for Bi-Xenon headlamps, LHD variant

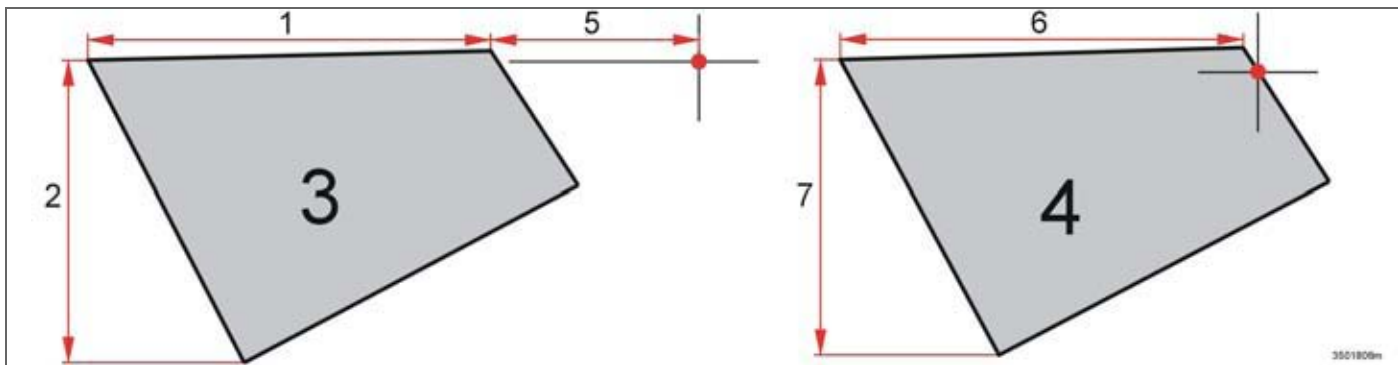

Masking templates for Bi-Xenon headlamps, RHD variant

06



BLIS (Blind Spot Information System) – option

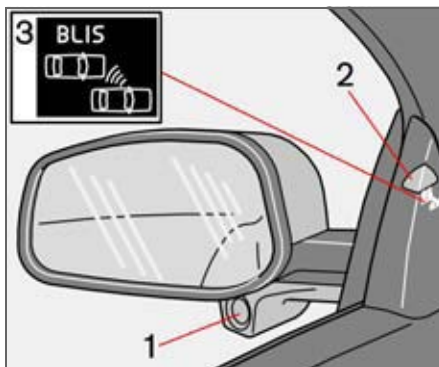

1 – BLIS camera, 2 – Indicator lamp,
3 – BLIS symbol

BLIS is an information system which indicates whether there is another vehicle moving in the same direction in the so-called "blind spot".

WARNING

The system is a supplement to, and not a replacement for, the existing rearview mirrors. It can never replace the awareness and responsibility of the driver. The responsibility for changing lanes safely rests with the driver.

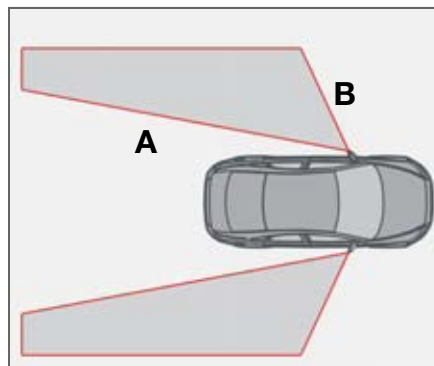

Blind spots covered by BLIS
Distance A = approx. 9.5 m
Distance B = approx. 3 m

The system is designed to work most effectively when driving in dense traffic on multi-lane highways.

BLIS is based on digital camera technology. The cameras (1) are fitted under the door mirrors.

When a camera has detected a vehicle inside the blind spot zone then an indicator lamp is lit in the door panel (2). The light illuminates with a constant glow to draw the driver's attention to a vehicle in the blind spot.

NOTE

The lamp illuminates on the side of the car where the system has detected the vehicle. If the car is overtaken on both sides at the same time then both lamps illuminate.

BLIS also has an integrated function which warns the driver if a fault should arise in the system. If, for example, the system's cameras are obscured then the BLIS indicator lamp flashes and a message is shown in the instrument panel display (see the table on page 151). In such cases, check and clean the lenses. If necessary, the system can be switched off temporarily by pressing the BLIS button (see page 151).

IMPORTANT

Repair of the BLIS system components must only be performed by an authorised Volvo workshop.



BLIS (Blind Spot Information System) – option

When BLIS operates

The system operates when the car is driven at a speed above 10 km/h.

When you overtake another vehicle

The system reacts if you overtake another vehicle at a speed of up to 10 km/h faster than the other vehicle.

When you are overtaken by another vehicle

The system reacts if you are overtaken by a vehicle travelling up to 70 km/h faster than you are travelling.

WARNING

BLIS does not work in sharp bends.
BLIS does not work when the car is reversing.
A wide trailer coupled to the car can conceal other vehicles in adjacent lanes. It can prevent the vehicle in the screened area from being detected by BLIS.

System function in daylight and darkness

Daylight

In daylight the system reacts to the **shape** of the surrounding vehicles. The system is designed to detect motor vehicles such as cars, trucks, buses and motorcycles

Darkness

In darkness the system reacts to the **headlamps** of surrounding vehicles. If its headlamps are not switched on then the system does not detect the vehicle. This means for example that the system does not react to a trailer without headlamps which is towed behind a car or truck.

WARNING

The system does not react to bicycles or mopeds.

The BLIS cameras can be disrupted by intensive light or when driving in the dark when there are no light sources (e.g. street lighting or other vehicles). The system may then interpret the lack of light as if the cameras have been blocked.

In both cases a message is shown on the display.

When driving in such conditions system performance may be temporarily reduced (see the information on the next page).

When the text message disappears the system returns to full functionality.

The BLIS cameras have the same limitations as the human eye, i.e. they "see" worse in heavy snowfall or thick fog for example.

Cleaning

In order to work most effectively the BLIS camera lenses must be clean. The lenses can be cleaned with a soft cloth or damp sponge. Clean the lenses carefully so that they are not scratched.

IMPORTANT

The lenses are electrically heated to melt ice or snow. If necessary, brush snow away from the lenses.



BLIS (Blind Spot Information System) – option

Switching off and reactivating BLIS

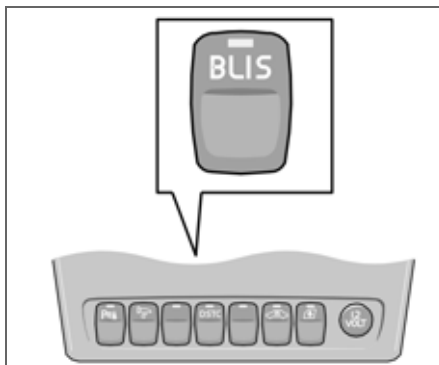

- BLIS is activated automatically each time the ignition is switched on. The indicator lamps in the door panels flash three times when the ignition is switched on.
- The system can be switched off by pressing the **BLIS** button in the switch panel in the centre console (see illustration above). The lamp in the button goes out when the system is switched off and a text message is shown in the display in the instrument panel.
- BLIS can be reactivated by pressing the button. A lamp in the button then illuminates, a new text message is shown in the display and the indicator lamps in the door

panels flash three times. Press the **READ** button, see page 45, to clear the text message.

BLIS system messages

| Specification | Text in the display |
|--|----------------------------------|
| BLIS system on | BLIND-SPOT INFO SYSTEM ON |
| BLIS not functioning | BLIND-SPOT SYST SERVICE REQUIRED |
| Right-hand camera blocked | BLIND-SPOT SYST R CAMERA BLOCKED |
| Left-hand camera blocked | BLIND-SPOT SYST L CAMERA BLOCKED |
| Both cameras blocked | BLIND-SPOT SYST CAMERAS BLOCKED |
| The BLIS camera is disrupted by fog or strong sunlight shining directly into the camera. The camera resets itself when the environment has returned to normal. | BLIS FUNCTION REDUCED |
| BLIS system off | BLIND-SPOT INFO SYSTEM OFF |



BLIS (Blind Spot Information System) – option

The messages above are only shown if the ignition key is in position II (or if the engine is running) and BLIS is active (i.e. if the driver has not switched off the system).

Limitations

In some situations the BLIS indicator lamp may illuminate despite there being no other vehicle within the blind spot.

i NOTE

If the BLIS indicator lamp illuminates on isolated occasions despite there being no other vehicle within the blind spot then this does not mean that a fault has arisen in the system.

In the event of a fault in the BLIS system the display shows the text **BLIS Serv. required.**

Here are several examples of situations where the BLIS indicator lamp may illuminate even if there is no other vehicle within the blind spot.

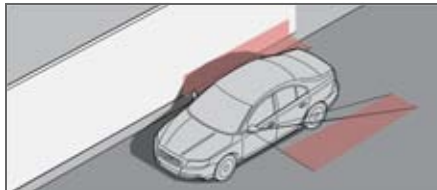

Own shadow on large, light, smooth surface, e.g. noise barrier or concrete road surface.



Low sun in the camera.



Reflection from shiny wet road surface.



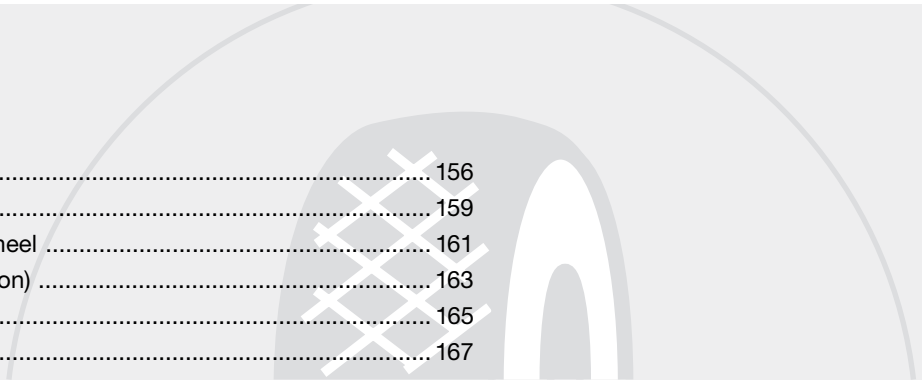

| | |
|---|-----|
| General | 156 |
| Tyre pressure | 159 |
| Warning triangle and spare wheel | 161 |
| Tyre pressure monitoring (option) | 163 |
| Changing wheels | 165 |
| Emergency puncture repair | 167 |

WHEELS AND TYRES



07

General

Driving characteristics and tyres

The tyres greatly affect the car's driving characteristics. The type of tyre, dimensions, tyre pressure and speed rating are important for how the car performs.

When changing tyres, ensure that tyres of the same type and dimensions, and preferably also the same make, are fitted to all four wheels. Follow the recommended tyre pressures specified on the tyre pressure label, see page 159.

Designation of dimensions

The dimensions are stated on all car tyres. Example: 205/55R16 91 W.

| | |
|-----|--|
| 205 | Section width (mm) |
| 55 | Ratio between section height and width (%) |
| R | Radial ply |
| 16 | Rim diameter in inches (") |
| 91 | Tyre load index (in this case 615 kg) |
| W | Speed rating (in this case 270 km/h). |

Speed ratings

The car has "Whole Vehicle Type Approval", which means that dimensions and speed ratings must not differ from those specified on the vehicle's registration document. The only exception to these conditions is winter tyres (both those with studs and those without). If such a tyre is chosen, the car must not be driven faster than the speed rating of the tyre (for example, class Q can be driven at a maximum of 160 km/h).

Remember that traffic regulations determine how fast a car can be driven, not the speed class of the tyres.

Note! Maximum permitted speeds indicated.

| | |
|---|---|
| Q | 160 km/h (used only on winter tyres) |
| T | 190 km/h |
| H | 210 km/h |
| V | 240 km/h |
| W | 270 km/h |
| Y | 300 km/h |

New tyres

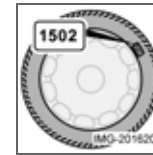

Tyres are perishable. After a few years they begin to harden at the same time as the friction capacity/characteristics gradually deteriorate. Therefore aim to get as fresh tyres as possible

when you replace them. This is especially important with regard to winter tyres. The week and year of manufacture, the tyre's DOT marking (Department of Transportation), are stated with four digits, for example 1502. The tyre in the illustration was manufactured in week 15 of 2002.

Tyre age

All tyres older than six years should be checked by an expert even if they seem undamaged. The reason for this is that tyres age and decompose, even if they are hardly ever or never used. The function can therefore be affected due to the tyre's constituent materials being broken down. In such a case the tyre should then not be used. This also applies to spare tyres, winter tyres and tyres saved for future use. Examples of external signs which indicate that the tyre is unsuitable for use are cracks or discoloration.

The age of the tyre can be determined by the DOT marking, see illustration above.



More even wear and maintenance

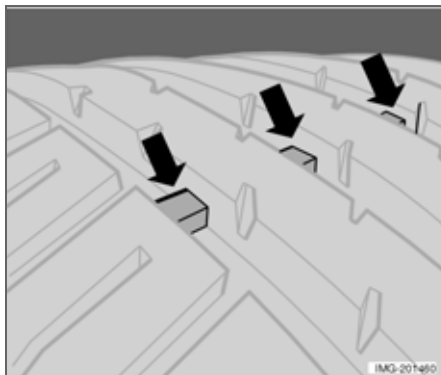

The correct tyre pressure results in more even wear, see page 160. To achieve the best traction and more even wear on the tyres, the regular switching of the front and rear tyres with each other is recommended. The first change should be after 5000 km and then at intervals of 10000 km, this is to avoid differences in tread depth. Tyres with the greatest tread depth should always be fitted to the rear wheels to decrease the risk of skidding. Contact an authorised Volvo workshop if you are uncertain about tread depth.

Wheels should be stored lying down or hanging up, and not standing up.



WARNING

A damaged tyre can lead to loss of control of the car.

Tyres with tread wear indicators

Tread wear indicators are narrow treadless bands across the width of the tread. On the side of the tyre are the letters TWI (Tread Wear Indicator). When the tyre's tread depth is down to 1.6 mm, the tread depth will be level in height with the tread wear indicators. Change to new tyres as soon as possible. Remember that tyres with little tread depth provide very poor grip in rain and snow.

Winter tyres

Volvo recommends winter tyres with particular dimensions. These are stated on the tyre pressure label, see page 159 for its location. The tyre dimensions are dependent on the engine variant. When driving on winter tyres, they must be fitted to all four wheels.



NOTE

Ask a Volvo dealer which rim and tyre types are most suitable.

Studded tyres

Studded winter tyres should be run in gently for 500–1000 km so the studs settle properly into the tyre. This gives the tyre, and especially the studs, a longer lifespan.



NOTE

The legal provisions for the use of studded tyres vary from country to country.

Tread depth

Road conditions with ice, slush and low temperatures place considerably higher demands on tyres than summer conditions. It is therefore not recommended to drive on winter tyres that have a tread depth of less than four mm.

Snow chains

Snow chains may only be used on the front wheels. This also applies to all-wheel-drive cars.

Never drive faster than 50 km/h with snow chains. Avoid driving on bare ground as this wears out both the snow chains and tyres. Never use quick-fit snow chains as the space between the brake discs and the wheels is too small.



General

! IMPORTANT

Use Volvo genuine snow chains or equivalent chains designed for the correct car model, and tyre and rim dimensions. Consult an authorised Volvo workshop

Locking wheel bolts

Locking wheel bolts can be used on both aluminium and steel rims. If steel rims with locking wheel bolts are used in combination with wheel covers then the locking wheel bolts must be fitted furthest from the air valve. Otherwise the wheel cover cannot be fitted on the rim.

Summer and winter wheels

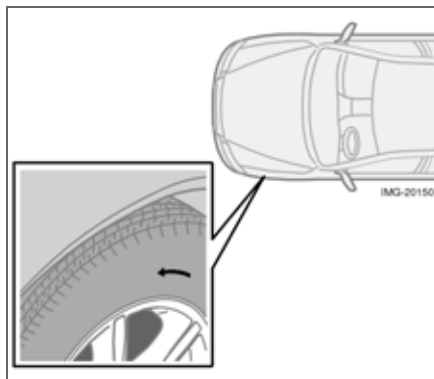

The arrow shows the tyre's direction of rotation

When summer and winter wheels are changed the wheels should be marked with which side of the car they were mounted on, for example **L** for left and **R** for right.

Tyres with tread patterns which are designed to only rotate in one direction have the direction of rotation marked with an arrow on the tyre. The tyre should always rotate in the same direction throughout its lifespan.

Tyres should only be switched between front and rear positions, never between left and right-hand sides, or vice versa. If the tyre is mounted incorrectly, the car's braking char-

acteristics and capacity to force rain, snow and slush out of the way are adversely affected.

Tyres with the greatest tread depth should always be fitted to the rear of the car (to decrease the risk of skidding).

Contact an authorised Volvo workshop if you are uncertain about tread depth.



Recommended tyre pressure

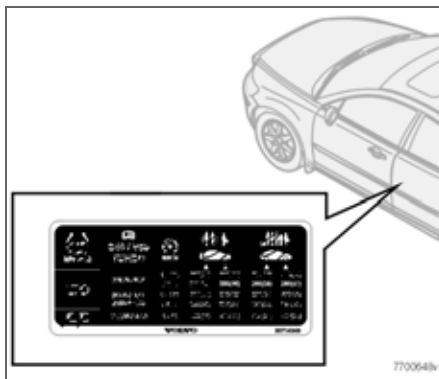

The tyre pressure decal on the driver's side door pillar (between frame and rear door) shows which pressures the tyres should have at different loads and speed conditions.

Stated on the decal:

- Tyre pressure for the car's recommended wheel size
- ECO pressure
- Spare wheel pressure (Temporary Spare).

Checking the tyre pressure

Check the tyre pressure regularly.

i NOTE

Tyre pressure decreases over time, this is a natural phenomenon. Tyre pressure also varies depending on ambient temperature.

The correct tyre pressure is specified in the tyre pressure table on page 160. The specified tyre pressures refer to "cold tyres". ("Cold tyres" means the tyres are the same temperature as the ambient temperature.)

Even after several kilometres of driving the tyres warm up and the pressure increases, so air must not be released if the pressure is checked when the tyres are warm, while the pressure must be increased if it is too low.

Inadequately inflated tyres increase fuel consumption, shorten tyre lifespan and impair the car's roadholding. Driving on tyres with tyre pressure that is too low can also result in the tyres overheating and disintegrating. For information on the correct tyre pressure, refer to the tyre pressure table.

Fuel economy, ECO pressure

At speeds under 160 km/h, the general tyre pressure for full load is recommended in order to obtain optimum fuel economy.

Tyre pressure affects travelling comfort, road noise and steering characteristics.



07 Wheels and tyres

Tyre pressure

Tyre pressure table

| Variant | Tyre size | Speed (km/h) | Load, 1-3 persons | | Max. load | |
|-----------------------------|-------------------------------------|--------------|---------------------------|------------------|------------------|------------------|
| | | | Front (kPa ¹) | Rear (kPa) | Front (kPa) | Rear (kPa) |
| T5 | 205/55R16 | 0 – 160 | 220 | 220 | 260 | 260 |
| | 215/55R16 | 160 + | 260 | 260 | 280 | 280 |
| | 225/45R17 235/40R18 | 0 – 160 | 260 ² | 260 ² | 260 ² | 260 ² |
| Others | 195/65R15 | 0 – 160 | 220 | 220 | 260 | 260 |
| | 205/55R16 | 160 + | 250 | 250 | 280 | 280 |
| | 215/55R16 225/45R17 235/40R18 | 0 – 160 | 260 ² | 260 ² | 260 ² | 260 ² |
| Spare wheel, Temp. spare | T125/80R17 | 0 – 80 | 420 | 420 | 420 | 420 |

¹In certain countries there is the "bar" unit beside the SI unit "Pascal": 1 bar = 100 kPa (260 kPa = 2.60 bar)

²ECO pressure, see page 159



Warning triangle and spare wheel

Warning triangle (certain countries)

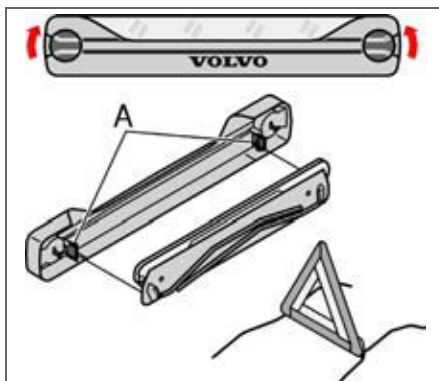

Follow the warning triangle regulations of the country you are in.

Use the warning triangle as follows:

- Turn both attachment screws to the vertical position.
- Carefully remove the warning triangle case.
- Remove the warning triangle from its case (A).
- Fold out the four support legs on the warning triangle.
- Fold out both red sides of the warning triangle. Place the warning triangle in a

location that is appropriate for the traffic situation.

After use

Pack everything in reverse order.

Make sure the warning triangle and its case are properly secured in the boot lid.

Spare wheel, tools and jack

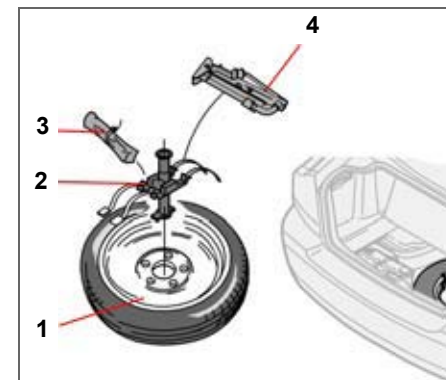

1. Spare wheel¹
2. Mounting
3. Tool kit¹ with towing eye
4. Jack¹

The spare wheel and jack and tool kit are located under the floor of the cargo area. Remove the spare wheel as follows:

- Fold the rear edge of the floor mat forward.
- Remove the jack and tool kit.
- Unscrew the spare wheel and lift it out.

¹ Option for certain variants and markets



Warning triangle and spare wheel

If the car is equipped with a carrier bag holder:

- Turn the two clips located at the rear corner of the mat 90 degrees.
- Pull the front of the floor mat back towards the boot lid opening.
- Lift the mat slightly and turn 90 degrees to lift it out.
- Lift the mat out of the cargo area.
- Unscrew the spare wheel and lift it out.

Return and secure everything in reverse order. Make sure that the spare wheel is securely in place and that the jack and tool kit are properly secured.

Spare wheel, "Temporary spare"

The spare wheel¹ "Temporary Spare" should only be used for the short time it takes to repair or replace the normal tyre.

By law, it is only legal to use the spare wheel/tyre temporarily in connection with damage to a tyre. A wheel/tyre of this type should be replaced with a normal wheel/tyre as soon as possible.

Remember also that this tyre combined with the normal tyres will affect driving characteristics. The maximum speed with the "Temporary Spare" - spare wheel is therefore 80 km/h.



IMPORTANT

Only use the car's own genuine spare wheel! Tyres with other dimensions may cause damage to your car. Only one spare wheel may be used at a time.

¹ Option for certain variants and markets



Tyre pressure monitoring (option)

Tyre pressure monitoring TPMS

The Tyre Pressure Monitoring System warns the driver when the pressure is too low in one or more of the car's tyres. It uses sensors located inside the air valve in each wheel. When the car is driven at approximately 40 km/h the system detects the tyre pressure. If the pressure is too low then a warning lamp on the instrument panel illuminates and a message is shown in the display.

Always check the system after changing a wheel in order to ensure that replacement wheels work with the system.

For information on correct tyre pressure, see page 159–160.

The system does not replace normal tyre maintenance.

IMPORTANT

If a fault should arise in the tyre pressure system a warning lamp on the instrument panel will illuminate. The message **TYRE PRESS. SYST SERVICE REQUIRED** will be shown. This can be for various reasons, e.g. fitting a wheel not equipped with a sensor adapted for Volvo's tyre pressure monitoring system.

Adjusting tyre pressure monitoring

Tyre pressure monitoring can be adjusted in order to follow Volvo's tyre pressure recommendations, when driving with a heavy load for example.

NOTE

The engine must not be running.

- Inflate the tyres to the required pressure.
- Select key position **I** or **II**.
- Turn the thumbwheel on the left-hand stalk switch until the text **TYRE PRESSURE CALIBRATION** is shown in the display.
- Press and hold the **RESET** button until the text **TYRE PRESSURE CALIBRATED** is shown.

Rectifying low tyre pressure

When the message **LOW TYRE PRESS. CHECK TYRES** is shown in the display:

- Check the tyre pressure in all four tyres.
- Inflate the tyre(s) to the correct pressure.
- Drive the car for at least 1 minute in total at a minimum of 40 km/h and check that the message disappears.

Deactivating tyre pressure monitoring

NOTE

The engine must not be running.

- Key position **I** or **II**.
- Turn the thumbwheel on the left-hand stalk switch until the text **TYRE PRESS. SYST ON** is shown in the display.
- Press and hold the **RESET** button until the text **TYRE PRESS. SYST OFF** is shown.

To reactivate the system repeat the same steps 1–3, so that **TYRE PRESS. SYST ON** is shown in the display.

Recommendations

Only factory fitted wheels are equipped with TPMS sensors in the valves.

- The temporary spare wheel does not have this sensor.
- If wheels without TPMS sensors are used then **TYRE PRESS. SYST SERVICE REQUIRED** will be shown every time the car is driven faster than 40 km/h for more than 10 minutes.
- Volvo recommends that TPMS sensors are fitted to all wheels on the car (summer and winter wheels).
- Volvo recommends that sensors are not moved between different wheels.



Tyre pressure monitoring (option)



WARNING

When inflating a tyre equipped with TPMS, hold the nozzle of the pump directly against the valve to avoid damaging the valve.

Driveable punctured tyres (option)

If Self Supporting run flat Tyres (SST) have been selected then the car is also equipped with TPMS.

This type of tyre has a specially reinforced side wall that makes continued driving possible despite the tyre losing some air. These tyres are fitted on a special rim. (Normal tyres can also be fitted to this rim).

If an SST tyre loses tyre pressure then the yellow TPMS lamp on the instrument panel illuminates and a message is shown in the text panel. If this occurs, reduce speed to max. 80 km/h. The tyre must be replaced as soon as possible.

Drive carefully, in some cases it can be difficult to see which tyre is faulty. In order to establish which tyre needs attention, check all four tyres.



WARNING

SST tyres should only be fitted by individuals with expertise on SST tyres.

SST tyres must only be fitted together with TPMS.

After a fault message on low tyre pressure has been shown, do not drive faster than 80 km/h.

Maximum driving distance to tyre change is 80 km.

Avoid hard driving.

SST tyres must be replaced if they are damaged or punctured.



Changing wheels

Removing wheels

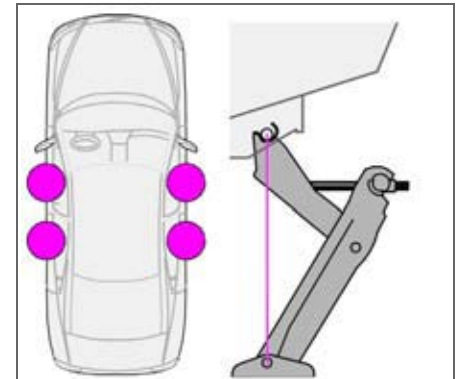
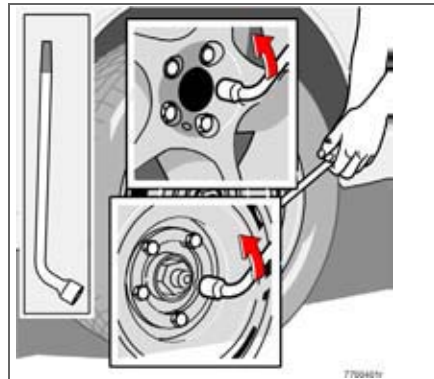
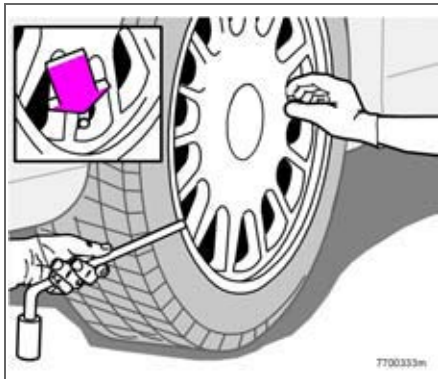

Remember to set out the warning triangle if you must change a wheel in a trafficked area. The spare wheel is under the plastic trough in the cargo area.

- Apply the parking brake and engage 1st gear on cars with manual gearbox – position P on cars with automatic gearbox.
 - Place chocks in front of and behind the wheels which will remain on the ground. Use heavy wooden blocks or large stones.
- Cars with steel wheel rims have removable wheel covers. Prise off the wheel cover with a thick screwdriver or the like. If tools are not available, the wheel cover can be prised off by hand. Use protective gloves. When refitting the wheel cover, make sure the cover is properly aligned over the air valve.
 - Loosen the wheel bolts 1/2-1 with the socket wrench. Loosen the nuts by turning them anticlockwise.
- There are two jacking points on each side of the car. Hold the jack against the pin in the jacking point as illustrated and crank the foot of the jack down so it is pressed squarely on the ground. Check that the jack sits in the anchorage as illustrated and that the foot is positioned vertically under the anchorage.
 - Lift the car so that the wheel is free.
 - Remove the wheel bolts and lift off the wheel.



Changing wheels

Fitting the wheel

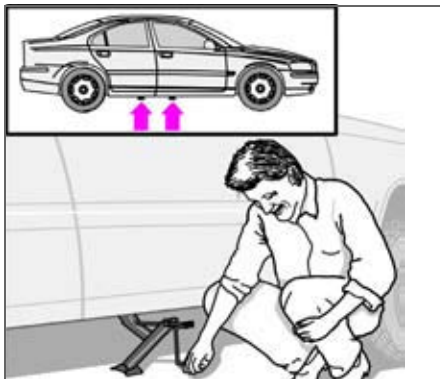

- Clean the contact surfaces on the wheel and hub.
- Fit the wheel. Screw the wheel nuts.
- Lower the car so that the wheel cannot rotate.
- Tighten the wheel nuts crosswise. It is important that the wheel nuts are tightened properly. Tighten to 140 Nm. Check the torque with a torque wrench.
- Put on the wheel cover (steel rim).

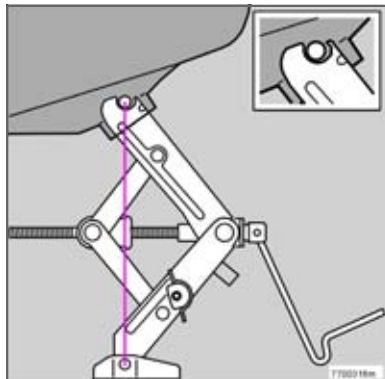

Certain variants



WARNING

- Never crawl under the car when it is raised on the jack.
- Passengers must leave the car when it is raised on the jack.
- Ensure that passengers wait with the car - or preferably a crash barrier - between them and the road.



IMPORTANT

If TPMS is specified then the tyres must be calibrated after fitting. Read "Adjusting tyre pressure", see page 163.



Emergency puncture repair

General

The emergency puncture repair kit¹ is used to seal the puncture and to check and adjust the tyre pressure. It consists of a compressor and a bottle with sealing fluid. The kit works as a temporary repair. The sealing fluid bottle must be replaced before its expiration date and after use.

The sealing fluid effectively seals tyres punctured in the tread.

NOTE

The emergency puncture repair kit is only intended for sealing tyres with a puncture in the tread.

NOTE

The jack is an option on cars equipped with emergency puncture repair kit.

The emergency puncture repair kit has limited abilities to seal tyres which have punctures in the wall of the tyre. Do not seal tyres with the emergency puncture repair kit if they have larger slits, cracks or similar damage.

12 V sockets for the compressor are located by the centre console in the front, by the rear seat and in the cargo area. Choose the electrical socket that is nearest the punctured tyre.

WARNING

You must not drive faster than 80 km/h after the emergency tyre repair kit has been used. Contact an authorised Volvo workshop for inspection of the sealed tyre (maximum driving distance is 200 km). The staff there can determine whether or not the tyre can be repaired or if it needs to be replaced..

Taking out the emergency puncture repair kit

The emergency puncture repair kit with compressor and tools are found under the floor in the cargo area.

- Fold away the rear edge of the floor mat, forward from the back.
- Lift up the emergency puncture repair kit.

¹ Certain variants and markets.

Emergency puncture repair

Overview

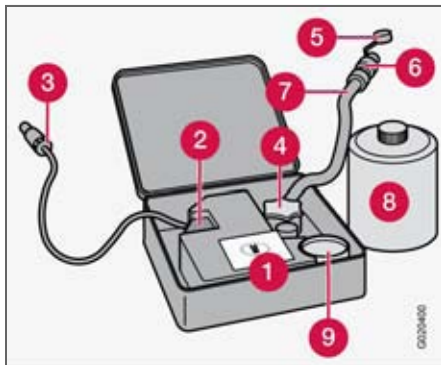

1. Decal, maximum permitted speed
2. Switch
3. Cable
4. Bottle holder (orange cap)
5. Protective cap
6. Pressure reducing valve
7. Air hose
8. Sealing fluid bottle
9. Pressure gauge

Inflating the tyres

The car's original tyres can be inflated by the compressor.

- The compressor must be switched off. Make sure that the switch is in position **0** and locate the cable and air hose.
- Unscrew the wheel's dust cap and screw in the air hose valve connection to the bottom of the thread on the tyre's air valve.
- Connect the cable to one of the car's 12 V sockets and start the car.

**WARNING**

Inhaling car exhaust fumes can result in danger to life. Never leave the engine running in enclosed areas or areas that lack sufficient ventilation.

- Start the compressor by flicking the switch to position **I**.
- Inflate the tyre to the pressure specified on the tyre pressure decal. (Release air using the pressure reducing valve if the tyre pressure is too high.)

**IMPORTANT**

Risk of overheating. The compressor must not run for more than 10 minutes.

- Switch off the compressor. Detach the air hose and cable.
- Refit the dust cap.



Emergency puncture repair

Sealing punctured tyres

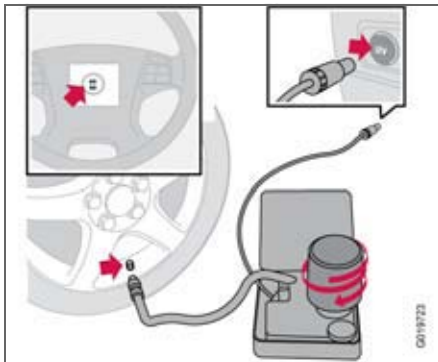

For information on the function of the parts, see the illustration on page 168.

- Open the lid of the emergency puncture repair kit.
- Detach the decal for maximum permitted speed and affix it to the steering wheel.
- Check that the switch is in position **0** and locate the cable and the air hose.

WARNING

The sealing fluid can irritate the skin. In the case of contact with skin, wash away the fluid with soap and water.

- Unscrew the orange cap and unscrew the bottle's stopper.

NOTE

Do not break the bottle seal. The seal is broken when the bottle is screwed in.

- Screw the bottle into its holder.

WARNING

Do not unscrew the bottle, it is equipped with a reverse catch to prevent leakage.

- Unscrew the wheel's dust cap and screw in the air hose valve connection to the bottom of the thread on the tyre's air valve.
- Plug the cable into the 12 V socket and start the car.
- Flick the switch to position **I**.

WARNING

Never stand next to the tyre when the compressor is running. If cracks or unevenness arise then the compressor must be switched off immediately. The journey should not be continued. Contact an authorised tyre centre.

NOTE

When the compressor starts, the pressure can increase up to 6 bar but the pressure drops after approximately 30 seconds.

- Inflate the tyre for 7 minutes.

IMPORTANT

Risk of overheating. The compressor must not run for more than 10 minutes.

- Switch off the compressor to check the pressure on the pressure gauge. Minimum pressure is 1.8 bar and maximum is 3.5 bar.

WARNING

If the pressure is below 1.8 bar then the hole in the tyre is too big. The journey should not be continued. Contact an authorised tyre centre.

- Switch off the compressor and unplug the cable from the 12 V socket.
- Detach the hose from the tyre valve and fit the valve cap.
- As soon as possible, drive approximately 3 km at a maximum speed of 80 km/h so that the sealing fluid can seal the tyre.



Emergency puncture repair

Rechecking the repair and pressure

- Reconnect the equipment.
- Read the tyre pressure on the pressure gauge.
- If it is below 1.3 bar then the tyre is insufficiently sealed. The journey should not be continued. Contact a tyre centre.
- If the tyre pressure is higher than 1.3 bar, the tyre must be inflated to the pressure specified on the tyre pressure decal. Release air using the pressure reducing valve if the tyre pressure is too high.
- Switch off the compressor. Detach the air hose and cable. Refit the dust cap.

WARNING

Do not unscrew the bottle, it is equipped with a reverse catch to prevent leakage.

- Return the emergency puncture repair kit to the cargo area.

NOTE

The sealing fluid bottle and hose must be replaced after use. Replacement must be performed by an authorised Volvo workshop.

WARNING

Check the tyre pressure regularly.

- Drive to the nearest authorised Volvo workshop for the replacement/repair of the damaged tyre. Advise the workshop that the tyre contains sealing fluid.

WARNING

You must not drive faster than 80 km/h after the emergency tyre repair kit has been used. Contact an authorised Volvo workshop for inspection of the sealed tyre (maximum driving distance is 200 km). The staff there can determine whether or not the tyre can be repaired or if it needs to be replaced.

Changing the sealing fluid canister

Replace the bottle when the expiration date has passed. Treat the old bottle as environmentally hazardous waste.

IMPORTANT

Read the safety instructions on the bottom of the bottle.





| | |
|-----------------------------|-----|
| Cleaning | 174 |
| Touching up paintwork | 177 |
| Rustproofing | 178 |

CAR CARE



08





Cleaning

Washing the car

Wash the car as soon as it becomes dirty. Use car shampoo. Dirt and road salt can lead to corrosion.

- Do not park the car in direct sunshine. Washing a car with hot paintwork can cause permanent paintwork damage. Wash the car in a car wash with waste water separator.
- Thoroughly rinse dirt off the underbody of the car.
- Rinse the entire car to remove loose dirt. When using a pressure washer: Make sure that the nozzle of the pressure washer is not closer than 30 cm to the bodywork. Do not spray directly at the locks.
- Wash using a sponge, car shampoo and plenty of lukewarm water.
- If the dirt is difficult to dislodge, wash the car using a cold degreasing agent.
- Dry the car using a clean, soft chamois or a water scraper.
- Clean the wiper blades with a lukewarm soap solution or car shampoo.



WARNING

Always have the engine cleaned by a workshop. There is a risk of fire if the engine is hot.



NOTE

Outside lighting such as headlamps, fog lamps and rear lamps may temporarily have condensation on the inside of the lens. This is a natural phenomenon, all outside lighting is designed to withstand this. Condensation is normally vented out of the lamp when it has been switched on for a time.

Removing bird droppings

Wash bird droppings off the paintwork as soon as possible. Bird droppings contain chemicals that affect and discolour paintwork very quickly. This discoloration can only be removed by a specialist.

Chromed wheels



IMPORTANT

Rim cleaning agents can cause stains on chrome-plated wheels. Wash using a sponge, car shampoo and plenty of lukewarm water.

Automatic car washes

An automatic car wash is a simple and quick way of washing the car, but it can never replace a proper handwashing. The brushes of an automatic car wash cannot reach everywhere.



WARNING

Always test the brakes after washing the car, including the parking brake, to ensure that moisture and corrosion do not attack the brake pads and reduce braking performance.



IMPORTANT

Washing by hand is gentler to the paintwork than an automatic car wash. Paintwork is also more sensitive when it is new. For this reason, handwashing is recommended during the first few months with a new car.

Press the brake pedal lightly from time to time if driving for long periods in rain or slush. This heats and dries the brake pads. You should also do this when you begin driving in extremely damp or cold weather.

Exterior plastic, rubber and trim components

A special cleaning agent available from Volvo dealers is recommended for cleaning coloured plastic parts, rubber and trim components, such as glossy trim mouldings. When using such a cleaning agent the instructions must be followed carefully.

**Cleaning****! IMPORTANT**

Avoid waxing and polishing on plastic and rubber.

Polishing glossy trim mouldings could wear away or damage the glossy surface.

Polishing agent that contains abrasive must not be used.

Polishing and waxing

Polish and wax the car if the paintwork is dull or to give the paintwork extra protection.

The car does not need to be polished until it is at least one year old. However, the car can be waxed during this time. Do not polish or wax the car in direct sunlight.

Wash and dry the car thoroughly before you begin polishing or waxing. Clean off asphalt and tar stains using Volvo tar remover or white spirit. More stubborn stains can be removed using fine rubbing paste designed for car paintwork.

Polish first with a polish and then wax with liquid or solid wax. Follow the instructions on the packaging carefully. Many preparations contain both polish and wax.

! IMPORTANT

Paint treatment such as preserving, sealing, protection, lustre sealing or similar could damage the paintwork. Paintwork damage caused by such treatment is not covered by Volvo warranty.

Cleaning door mirrors with water-repellent surface (option)

Never use products such as car wax, degreaser or similar on mirror surfaces as this could ruin their water-repellent properties.

Take care when cleaning so as not to damage the glass surface.

To avoid damaging glass surfaces when removing ice – only use plastic ice scrapers.

There is natural wear of the water-repellent coating.

Treatment with a special finishing agent available from Volvo dealers is recommended in order to maintain the water-repellent properties. This should first be used after three years and then each year.



Cleaning

Cleaning the interior

Treating stains on fabric upholstery

A special cleaning agent, available from Volvo dealers, is recommended for cleaning the fabric upholstery. Other chemicals can impair the fire retardant qualities of the upholstery.

! IMPORTANT

Sharp objects and Velcro may damage the fabric upholstery.

Treating stains on leather upholstery

Volvo leather upholstery is chromium-free and approved in accordance with the Öko-TEX 100 standard.

The leather is refined and processed so that it retains its natural characteristics. It is given a protective coating, but regular cleaning is required in order to maintain both characteristics and appearance. Volvo offers a comprehensive product for the cleaning and treatment of leather upholstery which, when used in accordance with the instructions, preserves the leather's protective coating.

After a period of use the natural appearance of the leather will nevertheless emerge, depending more or less on the surface tex-

ture of the leather. This is a natural maturing of the leather and shows that it is a natural product.

To achieve best results Volvo recommends cleaning and application of the protective cream once to four times per year (or more if required). Ask a Volvo dealer about Volvo's Leather care product.

! IMPORTANT

Never use strong solvents. Such products may damage fabric, vinyl and leather upholstery.

! IMPORTANT

Note that materials with colour that runs when dry (new jeans, suede garments etc.) may discolour the upholstery material.

Washing instructions for leather upholstery

- Pour the leather cleaner on the dampened sponge and squeeze out a strong foam.
- Work the dirt away with gentle circular movements.
- Dab the sponge accurately on the stains. Allow the sponge to absorb the stain. Do not rub.

- Wipe off with soft paper or a cloth and allow the leather to dry completely.

Protective treatment of leather upholstery

- Pour a small amount of the protective cream on the felted cloth and massage in a thin layer of cream with gentle circular movements on the leather.
- Allow the leather to dry for 20 minutes before use.

The leather has now been given improved protection against stains and improved UV protection.

Treating stains on interior plastic, metal and wood parts

A special cleaning agent, available from Volvo dealers, is recommended for cleaning interior plastic parts and surfaces. Do not scrape or rub stains. Never use strong stain removers.

Cleaning seatbelts

Use water and a synthetic detergent. A special textile cleaning agent is available from you Volvo dealer. Make sure the seatbelt is dry before allowing it to retract.



Touching up paintwork

Paintwork

Paint is an important part of the car's rust-proofing and should therefore be checked regularly. To avoid the onset of rust, damaged paintwork must be rectified immediately. The most common types of paintwork damage are stone chips, scratches, and marks on the edges of wings and doors.

Colour code



Data plate

It is important that the correct colour is used. The colour code number (1) is shown on the data plate, see page 248.

Stone chips and scratches

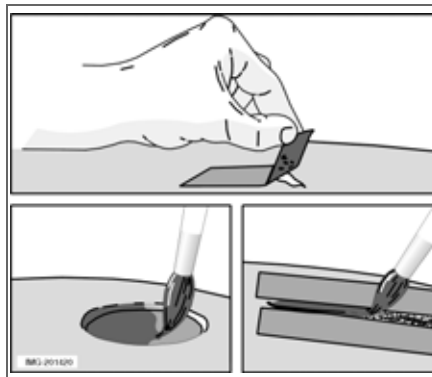

Before touching up paintwork, the car must be clean and dry and at a temperature above 15 °C.

Materials

- Primer in a can
- Paint in a can or touch-up pen
- Brush
- Masking tape

Minor stone chips and scratches

If the stone chip has not penetrated to the bare metal and there is an undamaged colour coat, you can paint straight after cleaning the damaged area.

If the stone chip has penetrated to the bare metal

- Fasten a piece of masking tape over the damaged surface. Then remove the tape, removing any paint residue.
- Stir the primer well and apply using a fine brush or matchstick. Apply paint using a brush once the primer is dry.
- For scratches, proceed as above, but mask around the damaged area to protect the undamaged paintwork.
- After a few days, polish the touched-up areas. Use a soft rag and a small amount of lapping paste.



Rustproofing

Inspection and maintenance

Your car received a thorough and complete rustproofing at the factory. Parts of the body are made of galvanised sheet metal. The underbody is protected by a wear-resistant anti-corrosion compound. And, a thin, penetrating rustproofing fluid was sprayed into the members, cavities and closed sections.

Maintaining the car's rustproofing.

- Keep the car clean. Hose down the underbody. If using a pressure washer, keep the nozzle at least 30 cm from the painted surfaces.
- Regularly check and touch-up the rustproofing treatment as necessary.

The car's rustproofing does not normally require treatment for approximately 12 years. After that time, it should be treated at three year intervals. If the car requires treatment, consult an authorised Volvo workshop.



[Empty rectangular box for text input]

| | |
|-------------------------------------|-----|
| Volvo service | 182 |
| Self-maintenance | 183 |
| Bonnet and engine compartment | 184 |
| Diesel | 185 |
| Oils and fluids | 186 |
| Wiper blades | 190 |
| Battery | 191 |
| Replacing bulbs | 193 |
| Fuses | 201 |

MAINTENANCE AND SERVICE

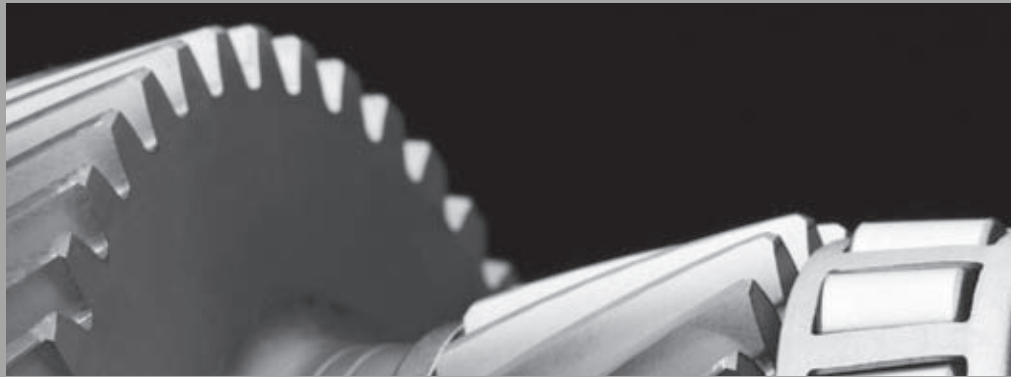

09



Volvo service

Volvo service programme

Before the car left the factory, it was thoroughly test driven. It was checked again in accordance with Volvo Car Corporation regulations before it was handed over to you.

To keep your Volvo as safe and reliable as possible, follow the Volvo service programme specified in the Service and Warranty Booklet. Have an authorised Volvo workshop carry out service and maintenance work. Volvo workshops have the personnel, special tools and service literature to guarantee the highest quality of service.

IMPORTANT

For the Volvo warranty to apply, check and follow the instructions in the Service and Warranty Booklet.

Special service measures

Certain service measures, which affect the car's electrical system, can only be performed using electronic equipment specially developed for your car. Always contact an authorised Volvo workshop before beginning or performing service work that affects the electrical system.

Installing accessories

The incorrect connection and installation of accessories can negatively affect the car's electrical system. Certain accessories only function when the appropriate software has been programmed into the car's electrical system. Always contact an authorised Volvo workshop before installing accessories which are connected to or affect the electrical system.

Recording vehicle data

One or more of the computers in your Volvo are capable of recording detailed information. This information is intended for use in research to enhance safety and for diagnosing faults in some of the in-car systems. The data may include details regarding seatbelt use by the driver and passengers, the functions of various vehicle systems and modules, and status information about the engine, throttle, steering, brakes and other systems. This data can also include details of the way the car is driven. This type of information can include, without being limited to, specific details such as vehicle speed, the use of the brake and accelerator pedals and steering wheel position. This latter type of data can be stored for a limited period while the car is being driven and subsequently during a collision or a near-collision. Volvo Car

Corporation will not disclose the stored information without consent. However, Volvo Car Corporation may be forced to disclose the information due to national legislation. Volvo Car Corporation and authorised Volvo workshops may also read and use the information.



Before starting work on the car

Battery

Check that the battery cables are correctly connected and tightened.

Never disconnect the battery when the engine is running (e.g. if replacing the battery).

Never use a quick charger to charge the battery. The battery cables must be disconnected when charging the battery.

The battery contains acid that is both corrosive and toxic. Handle the battery in an environmentally-suitable way. Let your Volvo dealer assist you.



WARNING

The car ignition system has very high voltage!

The voltage in the ignition system is dangerous!

Do not touch spark plugs, ignition cables or the ignition coil when the engine is running or the ignition is switched on!

The ignition should be switched off when:

- Conducting engine tests.
- Replacing parts in the ignition system, such as spark plugs, ignition coil, distributor, ignition cables, etc.

Lifting the car

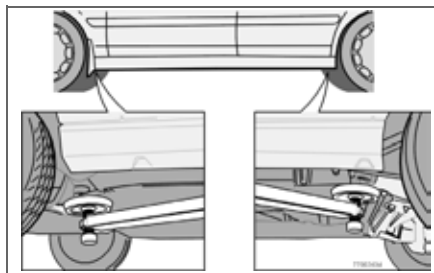

If the car is lifted with a workshop jack, it should sit with the front edge on the engine support arm. Do not damage the splash-guard under the engine. Ensure that the jack is positioned so that the car cannot slide off the jack. Always use axle stands or the like.

If you raise the car using a two pillar workshop lift, ensure that the front and rear lift arms are fixed under the lifting points on the door sill. See the illustration.

Check regularly

Check the following at regular intervals, for example, when refuelling:

- Coolant – The level must be between the **MIN** and **MAX** marks on the expansion tank.
- Engine oil – The level must be between the **MIN** and **MAX** marks.
- Power steering fluid – The level must be between the **MIN** and **MAX** marks.
- Washer fluid – The reservoir should be well filled. Use washer antifreeze at temperatures around freezing.
- Brake and clutch fluid – The level must be between the **MIN** and **MAX** marks.



WARNING

Bear in mind that the radiator fan may start automatically some time after the engine has been switched off.

Always have the engine cleaned by a workshop. There is a risk of fire if the engine is hot.



Bonnet and engine compartment

Opening the bonnet

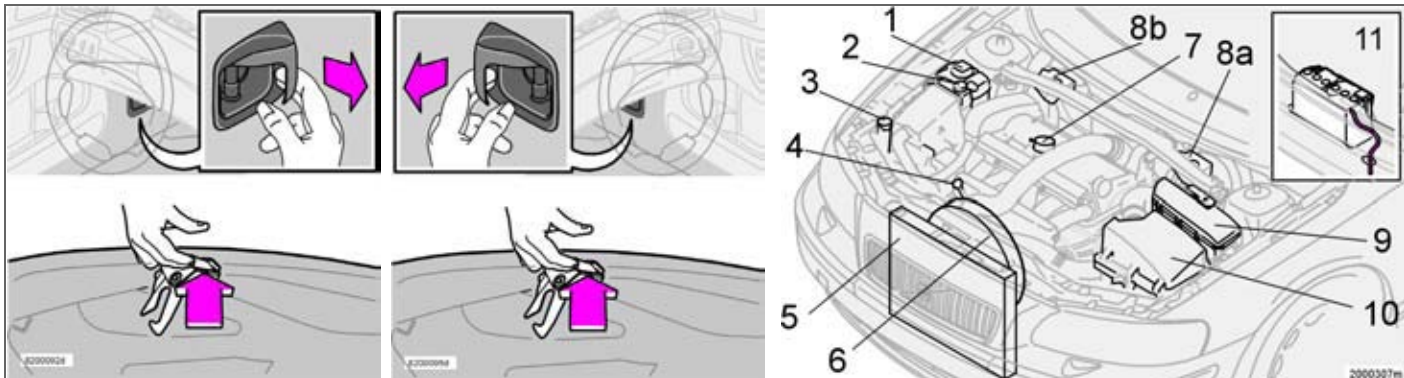

Left and right-hand drive cars.

To open the bonnet:

- Pull the handle on the far left under the instrument panel. You will hear when the catch releases.
- Insert your hand under the centre of the front edge of the bonnet and press the safety catch to the right.
- Open the bonnet.



WARNING

Check that the bonnet locks properly when closed.

Engine compartment

The appearance of the engine compartment may vary slightly due to engine variant. However, the components listed are in the same positions.

1. Expansion tank, cooling system
2. Power steering fluid reservoir.
3. Washer fluid reservoir
4. Engine oil dipstick
5. Radiator
6. Radiator fan

7. Engine oil filler pipe
8. a) Clutch/brake fluid reservoir (left-hand drive car).
b) Clutch/brake fluid reservoir (right-hand drive car).
9. Relay/fuse box.
10. Air filter. (The cover has a different design depending on engine variant.)
11. Battery (in cargo area)



Fuel system

Diesel must fulfil the EN 590 or JIS K2204 standards. Diesel engines are sensitive to contaminants such as high volumes of sulphur particles for example. Only use diesel fuel from a well-known producers. Never use diesel of dubious quality.

At low temperatures (−40 °C to −6 °C), a paraffin precipitate may form in the diesel fuel, which can lead to ignition problems. Special diesel fuel designed for low temperatures around freezing point is available from the major oil companies. This fuel is less viscous at low temperatures and reduces the risk of paraffin precipitate.

The risk of condensation in the fuel tank is reduced if the tank is kept well filled. When refuelling, check that the area around the fuel filler pipe is clean. Avoid spilling fuel onto the paintwork. Wash off any spillage with detergent and water.

IMPORTANT

Only ever use fuel that fulfils the European diesel standard, see page 259.

IMPORTANT

Diesel type fuels which must not be used: special additives, Marine Diesel Fuel, fuel oil, RME¹ (Rape Methyl Ester) and vegetable oil. These fuels do not fulfil the requirements in accordance with Volvo recommendations and they generate increased wear and engine damage not covered by the Volvo warranty.

¹ Diesel fuel may contain a certain amount of RME, but further amounts must not be added.

IMPORTANT

For model year 2006 or later the sulphur content must be a maximum of 50 ppm.

Empty tank

No special procedures are required if the tank is run dry. The fuel system is bled automatically if the ignition switch is kept in position **II** for approx. 60 seconds before the start attempt.

Draining condensation from the fuel filter

The fuel filter separates condensation from the fuel. Condensation can disrupt engine operation.

The fuel filter must be drained at the intervals specified in the Service and Warranty Booklet or if you suspect that the car has been filled with contaminated fuel.

IMPORTANT

Certain special additives remove the water separation in the fuel filter.



Oils and fluids

Engine compartment decal for oil grade

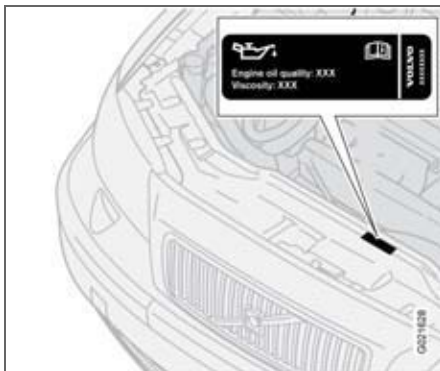

! IMPORTANT

Always use oil of the prescribed grade, see the engine compartment decal.

Check the oil level frequently and change the oil regularly.

The engine will be damaged if lower grade oil is used or if the car is driven with the oil level too low.

Volvo recommends Castrol oil products.

Using oil of a higher than specified grade is permitted. Volvo recommends using an oil of a higher grade than that specified on the

decal for adverse driving conditions. See page 255.

Adverse driving conditions

Check the oil level more frequently for long journeys:

- towing a caravan or trailer.
- in mountainous regions.
- at high speeds.
- in temperatures colder than $-30\text{ }^{\circ}\text{C}$ or hotter than $+40\text{ }^{\circ}\text{C}$.
- shorter driving distances (shorter than 10 km) at low temperatures (under $5\text{ }^{\circ}\text{C}$)

This may result in abnormally high oil temperature or oil consumption.

Checking and changing the engine oil and oil filter

Change the oil and oil filter in accordance with the intervals specified in the Service and Warranty Booklet.

! IMPORTANT

When filling oil to top up a low oil level, the oil being filled must be of the same grade and viscosity as the oil in the engine.

! IMPORTANT

In order to fulfil the requirements for the engine's service intervals all engines are filled with a specially adapted synthetic engine oil at the factory. The choice of oil has been made very carefully with regard to service life, starting characteristics, fuel consumption and environmental impact.

An approved engine oil must be used in order that the recommended service intervals can be applied.

Only use a prescribed grade of oil (see the engine compartment decal) for both filling and oil change, otherwise you will risk affecting service life, starting characteristics, fuel consumption and environmental impact.

Volvo Car Corporation disclaims all warranty liability if engine oil of the prescribed grade and viscosity is not used.

Volvo uses different systems for warning of low oil level or low oil pressure. Certain variants have an oil pressure sensor, and then a lamp is used for oil pressure. Other variants have an oil level sensor, and then the driver is informed via the warning symbol in the centre of the instrument unit as well as by display texts.



Certain models have both variants. Contact an authorised Volvo dealer for more information.

Checking the oil level in a new car is especially important before the first scheduled oil change. The Service and Warranty Booklet specifies the odometer readings for oil changes.

Volvo recommends checking the oil level every 2500 km. The most accurate measurements are made on a cold engine before starting. The measurement will be inaccurate if taken immediately after the engine is switched off. The dipstick will indicate that the level is too low because the oil has not had time to flow down into the oil sump.

Checking the oil

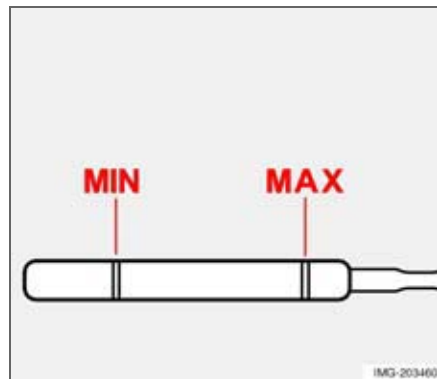

The oil level must be within the area marked on the dipstick.

Checking the oil in a cold engine:

- Wipe the dipstick clean before checking the level.
- Check the oil level using the dipstick. The oil level must be between the **MIN** and **MAX** marks.

If the level is close to the **MIN** mark, start by topping up with 0.5 litres of oil. Top up until the oil level is nearer the **MAX** than the **MIN** mark on the dipstick. See page 254–255 for capacities.

Checking the oil in a warm engine:

- Park the car on a level surface, switch off the engine and wait 10–15 minutes to allow the oil time to run back to the sump.
- Wipe the dipstick clean before checking the level.
- Check the oil level using the dipstick. The oil level must be between the **MIN** and **MAX** marks.

If the level is close to the **MIN** mark, start by topping up with 0.5 litres of oil. Top up until the oil level is nearer the **MAX** than the **MIN** mark on the dipstick. See page 254–255 for capacities.



WARNING

Do not spill oil onto the hot exhaust manifold due to the risk of fire.



IMPORTANT

Never fill above the **MAX** mark. Oil consumption may increase if too much oil is poured into the engine.



Oils and fluids

Washer fluid reservoir

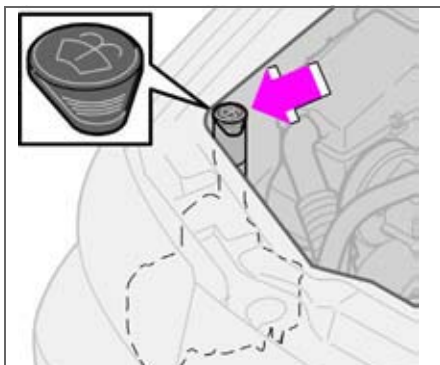

Washer fluid reservoir.

The windscreen and headlamp washers have the same fluid reservoir. See capacities and recommended grade for fluids on page 256.

Use washer fluid during the winter so that the fluid does not freeze in the pump, reservoir and hoses.

Tip: clean the wiper blades when topping up washer fluid. Mix the washer antifreeze with water before filling the reservoir.

Coolant

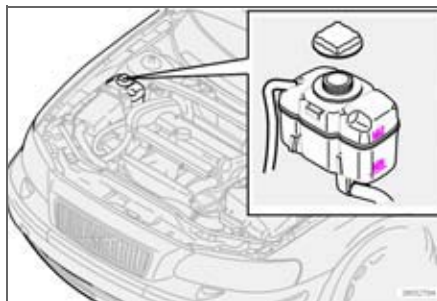

Coolant reservoir.

Check the coolant regularly. The level should lie between the MIN and MAX marks on the expansion tank. Top up with fluid when the level has fallen to the MIN mark.

See capacities and recommended grade for fluids and oils on page 256.

When topping up the coolant, follow the instructions on the packaging. It is important that the mixture of coolant concentrate and water is correct for the prevailing weather conditions. Never top up with water only. The risk of freezing increases with both too little and too much coolant concentrate.



WARNING

The coolant may be very hot. If the coolant requires topping up when the engine is at operating temperature, unscrew the expansion tank cap slowly to gently release the overpressure.



IMPORTANT

Always use coolant with anti-corrosion agent as recommended by Volvo. New cars are filled with coolant that can withstand temperatures down to approximately -35°C .

The engine must only be run with a well-filled cooling system. High temperatures can occur, causing a risk of damage (cracks) to the cylinder head.



Clutch and brake fluid reservoir

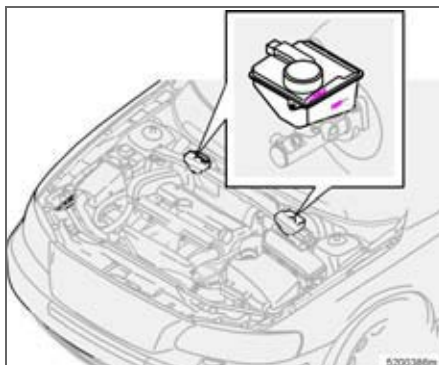

Location dependent on whether car is left or right-hand drive.

The brake and clutch fluid have a common reservoir¹. The fluid level must be between the MIN and MAX marks. Check the level regularly. Change the brake fluid every other year or at every other regular service.

See capacities and recommended grade for fluids and oils on page 256.

¹ Location dependent on whether car is left or right-hand drive.

WARNING

If the brake fluid is under the **MIN** level in the brake fluid reservoir, do not drive further before topping up the brake fluid.

The reason for the loss of brake fluid must be investigated.

NOTE

The fluid should be changed annually on cars driven in conditions requiring hard, frequent braking, such as driving in mountains or tropical climates with high humidity.

Power steering fluid reservoir

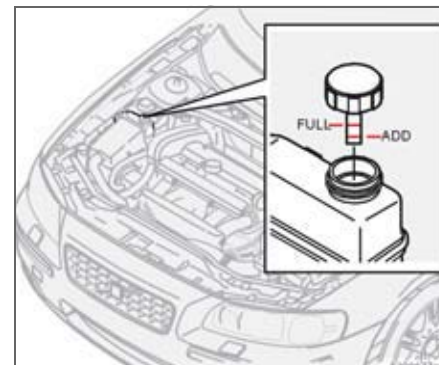

Check the level at every service. It is not necessary to change the fluid. The level should lie between the **ADD** and **FULL** marks.

See capacities and recommended grade for fluids and oils on page 256.

NOTE

It is possible to steer if a fault should occur in the power steering system or if the car loses electrical power and requires towing. Bear in mind that steering will be more difficult than normal and more force will be required to turn the steering wheel.



Wiper blades

Replacing windscreen wiper blades

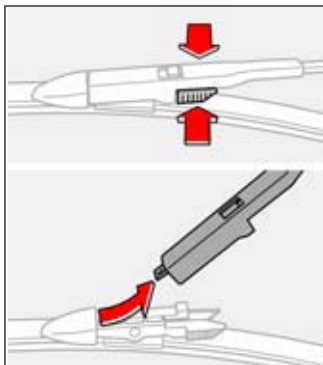

TIP! Clean the wiper blades when topping up washer fluid. Mix the washer antifreeze with water before filling the reservoir.

NOTE

Bear in mind that the wiper blade on the driver's side is longer than the one on the passenger side.

- Fold out the wiper arm and grasp the wiper blade.
- Press in the ribbed spring catch on the wiper blade while lifting it off at the arm extension.
- Fit the new blade in reverse order and check that it is properly secured.



Battery care

The service life and function of the battery is influenced by factors such as the number of starts, discharging, driving style, driving conditions and climatic conditions.

NOTE

An expended battery must be recycled in an environmentally responsible manner as it contains lead.

WARNING

Batteries can generate oxyhydrogen gas, which is highly explosive. One spark, which can be generated if you connect the jump leads incorrectly, is sufficient to make the battery explode.

The battery contains sulphuric acid, which can cause serious burns. If the acid comes into contact with eyes, skin or clothing, flush with large quantities of water. If acid splashes into the eyes, seek medical attention immediately.

NOTE

The life of the battery is shortened if it becomes discharged repeatedly.

Symbols on the battery

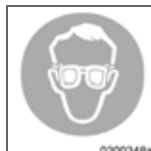

Use protective goggles.



Further information in the owner's manual.



Store the battery out of the reach of children.



The battery contains corrosive acid.



Avoid sparks and naked flames.



Risk of explosion.



Battery

Changing the battery

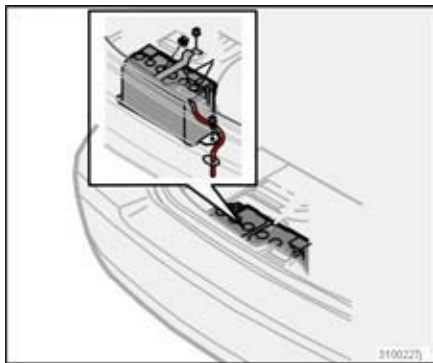

Removing the battery

- Switch off the ignition and remove the key.
- Wait at least 5 minutes before touching any electrical terminals. This allows time for the information in the car's electrical system to be stored in the control modules.
- Undo the screws from the lock brace over the battery and remove the brace.
- Bend up the plastic cover over the negative battery terminal or unscrew the cover from the battery.
- Disconnect the negative battery lead.

- Detach the lower console holding the battery.
- Bend aside the plastic cover and disconnect the positive cable.
- Undo the evacuation hose.
- Remove the battery.

Fitting the battery

- Fit the battery into position.
- Position the lower console and screw it in place.
- Connect the positive cable, press in and fold down the plastic cover.
- Connect the negative cable, fold down the plastic cover.
- Fit the plastic cover or the cover over the battery.
- Make sure the evacuation hose is correctly connected to both the battery and the outlet in the bodywork.
- Fit the lock brace over the battery and tighten the screws.



Replacing bulbs

General

All bulb specifications are given on page 262.

The following list contains bulbs and point-source lamps that are specialised or unsuitable for changing except at a workshop:

- Active Bi-Xenon and Bi-Xenon lamp
- General interior lighting in the roof
- Reading lamps
- Glovebox lighting
- Direction indicators in the door mirrors
- Approach lighting in the door mirrors
- High-level brake light
- LED lights in rear lamp cluster.

**WARNING**

On cars with Bi-Xenon and Active Bi-Xenon headlamps the replacement of the Xenon lamp must be carried out by an authorised Volvo workshop. The headlamps must be handled with extreme care due to the high-voltage unit in the Xenon lamp.

**IMPORTANT**

Never touch the bulbs' glass with your fingers. Grease and oils from your fingers are vaporised by the heat, coating and damaging the reflector.

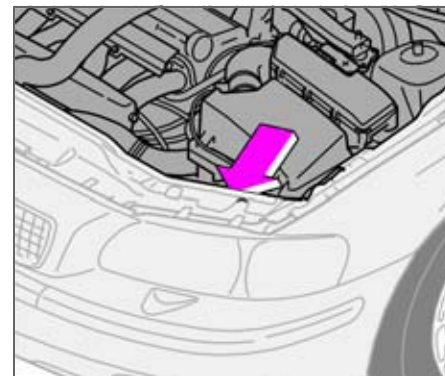
Changing front bulbs

All front bulbs (except for fog lamps) are changed by first removing the lamp housing from the engine compartment.

**NOTE**

If you experience difficulty when replacing a bulb then we recommend that you contact an authorised Volvo workshop.



Replacing bulbs

Location of the bulbs in the headlamp

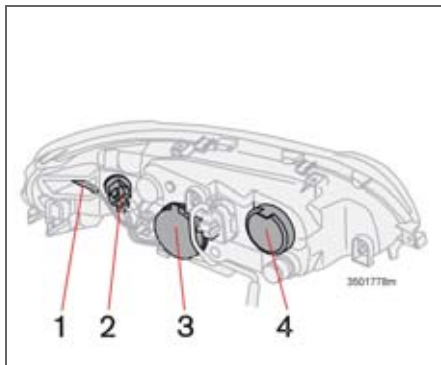

1. Side marker lamp
2. Direction indicator
3. Dipped beam lamp, position lamp (halogen and Bi-Xenon)
4. Main beam lamp, position lamp (Active Bi-Xenon)

On certain variants, a white plastic sleeve may impede bulb replacement. This can be broken off and discarded.

Dipped beam, halogen

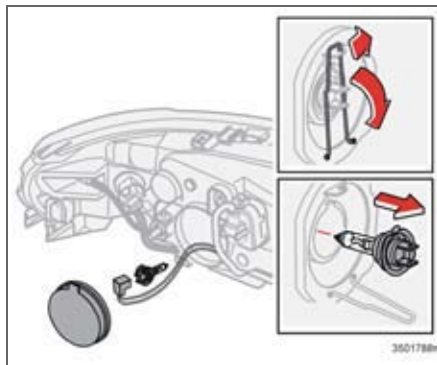

To remove the bulb

- Switch off all lights and turn the ignition key to position 0.
- Remove the cover.
- Unplug the connector.
- Disconnect the spring clamp. First push to the right so that the spring disconnects and then out and down.
- Pull out and remove the bulb.

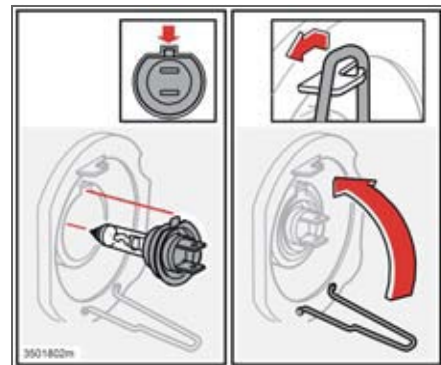

To fit

- Fit the new bulb. It can only be positioned one way.
- Press the clamp spring upwards and a little to the left so that it secures in its catch.
- Plug in the connector.
- Refit the cover.



Replacing bulbs

Main beam

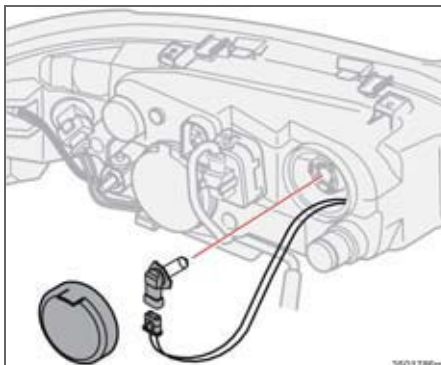
**To remove the bulb**

- Switch off all lights and turn the ignition key to position **0**.
- Remove the cover.
- Turn the bulb anticlockwise and pull it out.
- Undo the connector by pressing the catch out and then pulling.

To fit

- Plug the connector into the bulb, a click is heard.
- Refit the bulb, turn it in position.
- Refit the cover.

Position/parking lamps

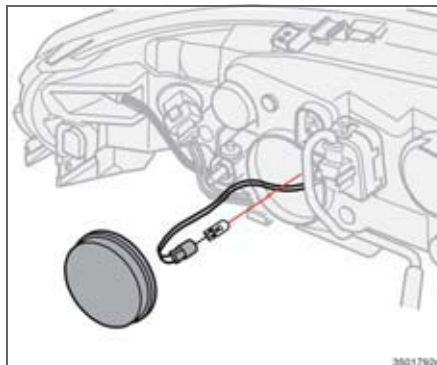
*Halogen and Bi-Xenon headlamps***To remove the bulb**

- Switch off all lights and turn the ignition key to position **0**.
- Remove the cover (same cover as for dipped beam).
- Pull out the lamp.
- Unplug the connector.

To fit

- Fit the new bulb.
- Plug in the connector.
- Refit the cover.

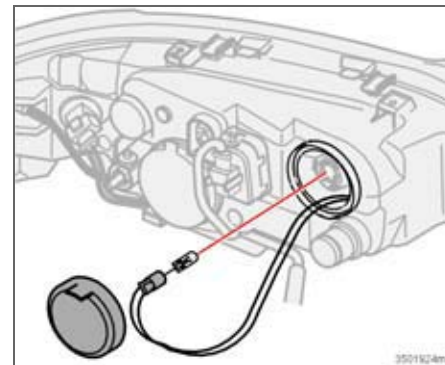
*Active Bi-Xenon headlamps***To remove the bulb**

- Switch off all lights and turn the ignition key to position **0**.
- Remove the cover (same cover as for dipped beam).
- Pull out the lamp.
- Unplug the connector.

To fit

- Fit the new bulb.
- Plug in the connector.
- Refit the cover.



Replacing bulbs

Direction indicator, left-hand side

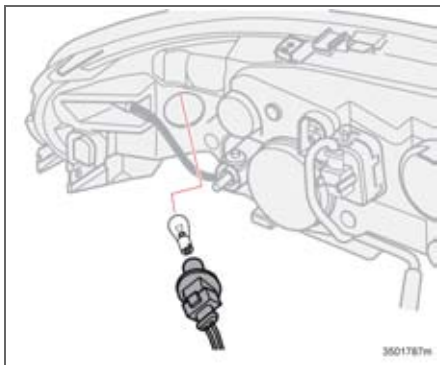

To remove the bulb

- Switch off all lights and turn the ignition key to position **0**.
- Twist the bulb holder anticlockwise and remove it.
- Press the bulb inwards, turn it anticlockwise and remove it from the bulb holder.

To fit

- Fit the new bulb by pressing it in and turning it clockwise.
- Refit the bulb holder in the lamp housing and turn it clockwise.

Direction indicator, right-hand side

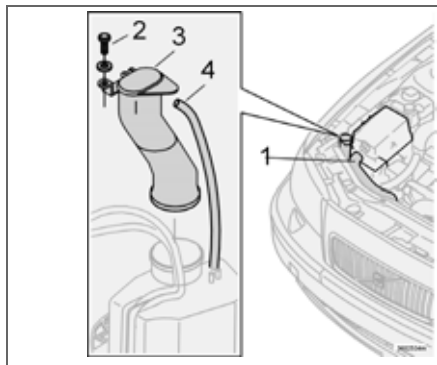

- Switch off all lights and turn the ignition key to position **0**.
- Remove the radiator hose (1) from the radiator.
- Remove the screw (2) to the filler pipe.
- Pull the pipe (3) straight up.
- Remove the ventilation hose (4) from the pipe.
- Replace the bulb.
- Check that the washer fluid reservoir gasket between the filler pipe and the holder is properly secured.
- Put the filler pipe (3) back into place.

- Refit the ventilation hose onto the filler pipe (4).
- Screw in the screw (2) to the filler pipe and refit the radiator hose to the radiator (1).



Replacing bulbs

Side marker lamps

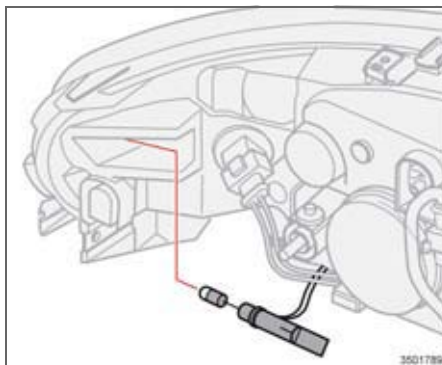

- Turn the bulb holder clockwise and pull it out.
- Replace the bulb.
- Refit the bulb holder by turning it anti-clockwise.

Front fog lamps (option)

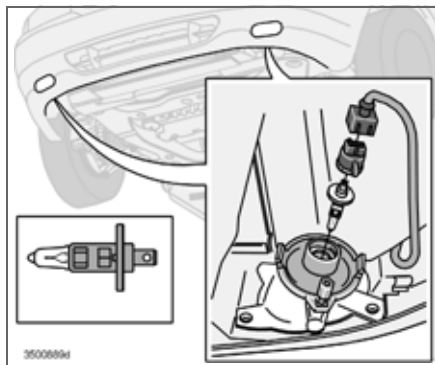
**To remove the bulb**

- Switch off all lights and turn the ignition key to position **0**.
- Turn the bulb holder slightly anticlockwise.
- Pull out and remove the bulb.

To fit

- Fit the new bulb. In can only be positioned one way.
- Refit the bulb holder, turn it clockwise slightly. The "**TOP**" mark must be upward.

Cargo area

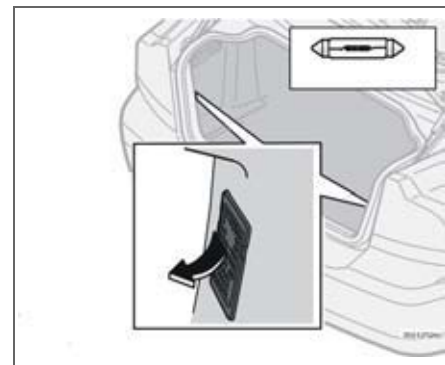

- Insert a screwdriver and gently turn so that the lamp housing comes loose.
- Remove the bulb.
- Fit a new bulb.
- Refit the lamp housing.



Replacing bulbs

Number plate lighting

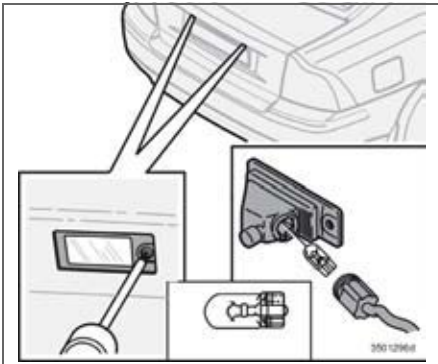

- Switch off all lights and turn the ignition key to position **0**.
- Remove the screw with a screwdriver.
- Carefully remove the entire lamp housing and pull it out. Turn the contact anticlockwise and pull out the bulb.
- Fit the new bulb.
- Plug in the connector and turn it clockwise in the lamp housing.
- Refit the entire lamp housing and screw it into place.



Replacing bulbs

Rear light cluster

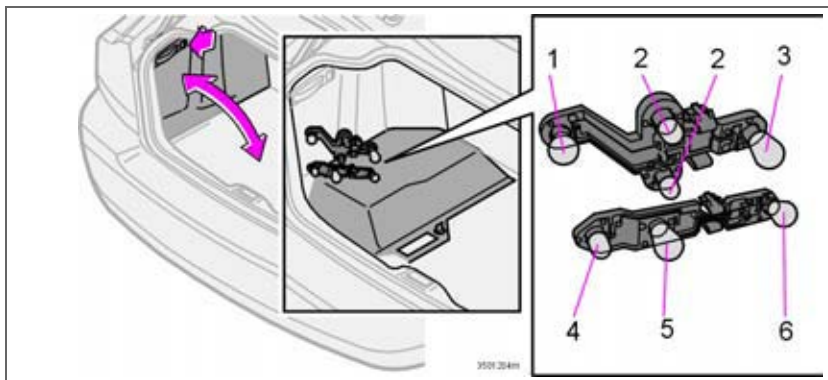

Location of bulbs

1. Brake light
2. Position/parking lamps
3. Rear fog lamp (one side)
4. Side marker lamps
5. Direction indicators
6. Reversing lamp

Removing

All bulbs in the rear lamp cluster can be replaced from inside the cargo area.

Bulb specifications can be found on page 262.

- Switch off all lights and turn the ignition key to position **0**.
- Unlock and fold down the side panel to access the bulbs.

The bulbs are located in two separate bulb holders, an upper and a lower. Each bulb holder has a locking pin.

To replace the bulb

- Detach the connector from the bulb holder.

- Press the catches together and pull out the holder.
- Remove the bulb.
- Fit the new bulb in the holder.
- Plug in the connector.
- Close and secure the side panel.

i NOTE

If the message **BULB FAILURE/CHECK STOP LAMP** remains after a faulty bulb has been replaced then an authorised Volvo workshop must be consulted.



Replacing bulbs

Courtesy lighting

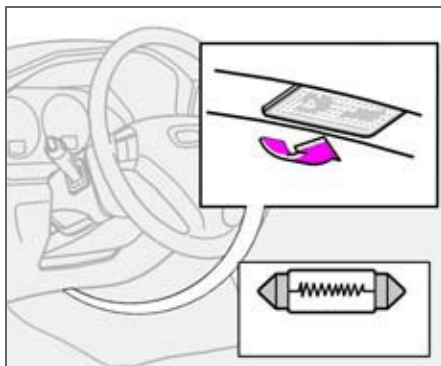

There is courtesy lighting under the instrument panel on the driver and passenger sides.

- Insert a screwdriver and gently turn so that the lamp housing comes loose.
- Remove the bulb.
- Fit a new bulb.
- Refit the lamp housing.

Vanity mirror lighting

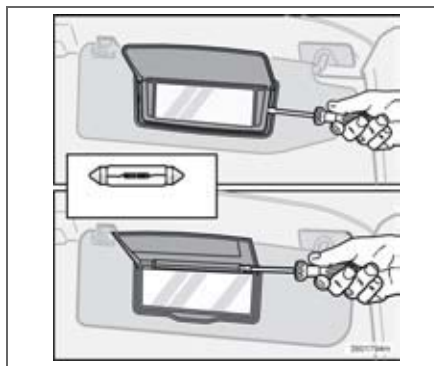

Vanity mirror, different versions

- Insert a screwdriver and turn so that the lamp lens releases.
- Remove the bulb.
- Fit a new bulb.
- First press the bottom of the lamp glass back into place above the four hooks. Then press the top in place.



General

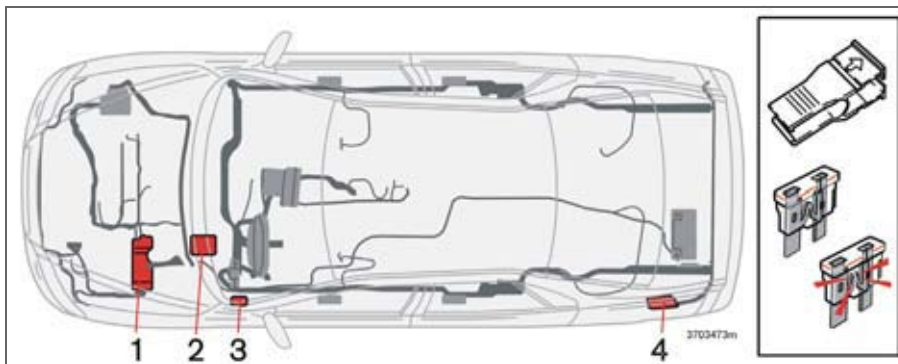

Cable routing may vary slightly due to engine variant. However, the components listed are in the same positions.

All electrical functions and components are fused to protect your car's electrical system from damage by short circuiting and overloading.

Fuses are housed in four different locations in the car:

1. Relay/fuse box in the engine compartment.
2. Fuse box in the passenger compartment within the sound barrier on the driver's side.

3. Fuse box in the passenger compartment at dashboard end on driver's side.
4. Fuse box in cargo area.

Changing

If an electrical component or function does not work, this may be because the component's fuse was temporarily overloaded and blew.

- Look in the fuse diagram to locate the fuse.

- Pull out the fuse and check from the side to see whether the curved wire has blown.
- If this is the case, replace it with a new fuse of the same colour and amperage.

There are a number of spare fuses in the cover on the end of the dashboard. There are also pliers which facilitate the removal and fitting of fuses.

If the same fuse blows repeatedly, there is a fault in the component, and you should contact an authorised Volvo workshop to have it checked.



Fuses

Relay/fuse box in the engine compartment

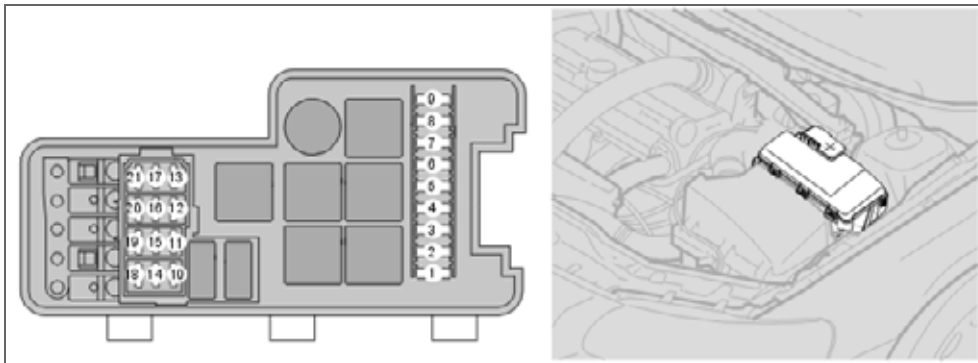

Press in the plastic catches on the short sides of the box and pull the cover upward.

- | | | | |
|--|------|--|------|
| 1. ABS..... | 30 A | 11. Accelerator pedal sensor (APM), AC compressor, fan electronics box | 10 A |
| 2. ABS | 30 A | 12. Engine control module (ECM) (petrol) injection valves (petrol), ... mass air flow sensor (petrol)..... | 15 A |
| 3. High-pressure washer, headlamps..... | 35 A | mass air flow sensor (diesel) | 5 A |
| 4. Parking heater (option)..... | 25 A | 13. Electronic throttle module (ETM), (petrol)..... | 10 A |
| 5. Auxiliary lamps (option)..... | 20 A | Electronic throttle module (ETM), air mixing valve, fuel pressure regulator, solenoid valve, (diesel) | 15 A |
| 6. Starter motor relay..... | 35 A | 14. Lambda-sond (petrol)..... | 20 A |
| 7. Windscreen wipers | 25 A | Lambda-sond (diesel) | 10 A |
| 8. Fuel pump | 15 A | 15. Crankcase ventilation heater, solenoid valves (petrol)..... | 10 A |
| 9. Transmission control module (TCM), diesel..... | 15 A | solenoid valves, glow plugs (diesel)..... | 15 A |
| 10. Ignition coils (petrol), engine control module (ECM), injection valves (diesel) | 20 A | 16. Dipped beam, left | 20 A |



Fuses

09

- 17. Dipped beam, right 20 A
- 18. - -
- 19. Engine control module (ECM) supply, engine relay 5 A
- 20. Position lamps 15 A
- 21. -



Fuses

Fuses in the passenger compartment at instrument panel end face on driver's side

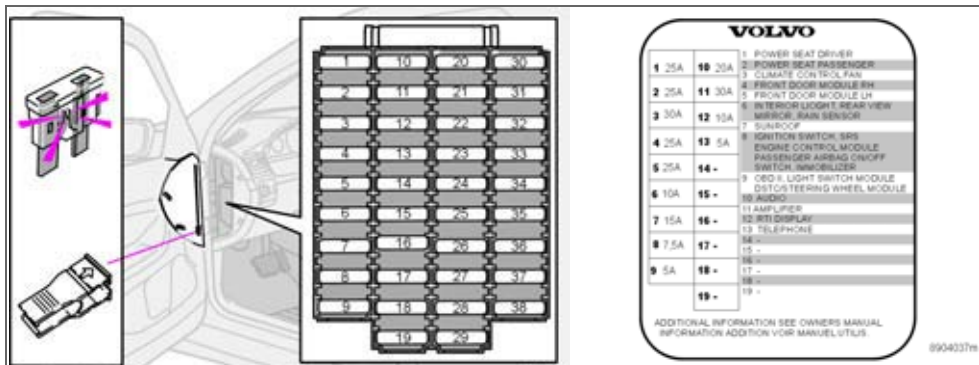

A decal which indicates the positions and amperages of the fuses is located in the end box cover.

- | | |
|---|--|
| 1. Power driver's seat 25 A | 9. OBDII, light switch (LSM), Steering Angle Sensor (SAS), Steering Wheel Module (SWM) 5 A |
| 2. Power passenger seat 25 A | 10. Audio 20 A |
| 3. Climate control system fan 30 A | 11. Amplifier 30 A |
| 4. Control module, right front door 25 A | 12. RTI display 10 A |
| 5. Control module, left front door 25 A | 13. Phone 5 A |
| 6. General lighting, ceiling (RCM) Upper electronic module (UEM) 10 A | 14. - 38 - |
| 7. Sunroof 15 A | |
| 8. Ignition switch, SRS system, engine control module (ECM) deactivating SRS passenger side, (PACOS), electronic immobiliser (IMMO), transmission control module (TCM), diesel, 7.5 A | |



Fuses in the passenger compartment within the sound barrier on the driver's side

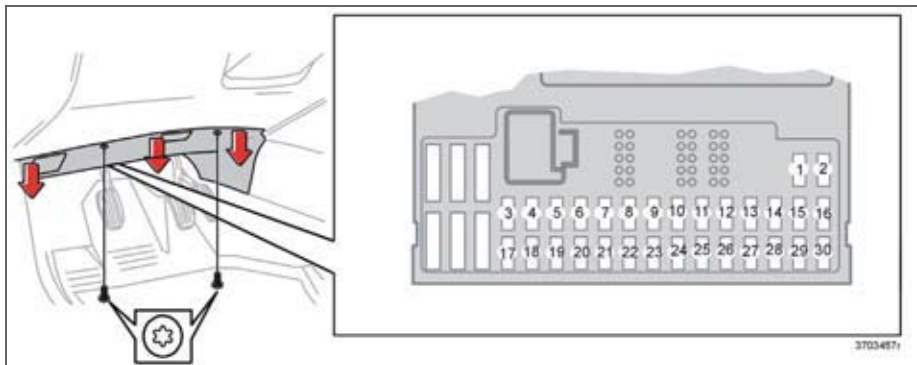

| | | | |
|--|------|--|-------|
| 1. Seat heating, right side | 15 A | 11. Front and rear seat socket | 15 A |
| 2. Seat heating, left side | 15 A | 12. - | - |
| 3. Horn | 15 A | 13. Reserve | - |
| 4. - | - | 14. - | - |
| 5. - | - | 15. ABS, STC/DSTC | 5 A |
| 6. Reserve | - | 16. Electronic power steering (ECPS), Active Bi-Xenon (HCM), headlamp levelling | 10 A |
| 7. Reserve | - | 17. Fog lamp, front left | 7.5 A |
| 8. Siren | 5 A | 18. Fog lamp, front right | 7.5 A |
| 9. Brake lamp switch feed | 5 A | 19. Reserve | - |
| 10. Combined instrument panel (DIM), climate control (CCM), parking heater, power driver's seat | 10 A | 20. Reserve | - |



Fuses

| | |
|--|-------|
| 21. Transmission Control Module (TCM), reverse gear inhibitor (M66) | 10 A |
| 22. Main beam, left | 10 A |
| 23. Main beam, right | 10 A |
| 24. - | - |
| 25. - | - |
| 26. Reserve | - |
| 27. Reserve | - |
| 28. Power passenger seat, audio | 5 A |
| 29. BiFuel, fuel pump | 7,5 A |
| 30. BLIS | 5 A |
| 31. Reserve | - |
| 32. Reserve | - |
| 33. Vacuum pump | 20 A |
| 34. - | - |
| 35. - | - |
| 36. - | - |



Fuses

Fuses in the cargo area

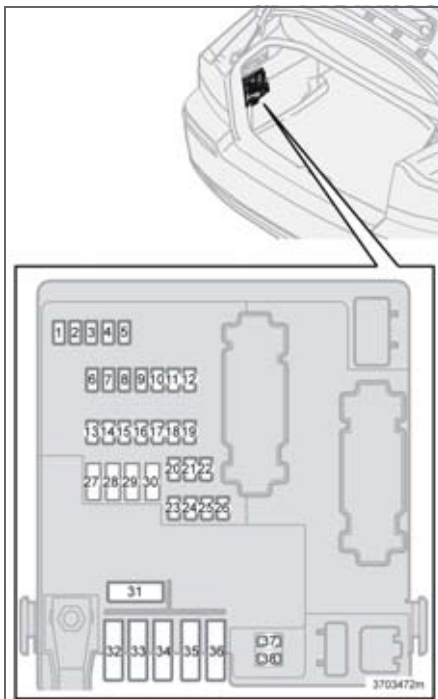

- | | |
|--|-------|
| 1. Reversing lamp..... | 10 A |
| 2. Position lamps, fog lamps, cargo area lighting, number plate lighting, lamps in brake lighting | 20 A |
| 3. Accessories (AEM) | 15 A |
| 4. Reserve | - |
| 5. REM electronics..... | 10 A |
| 6. CD changer, TV, RTI..... | 7.5 A |
| 7. Towing bracket wiring (30-feed) | 15 A |
| 8. Cargo area socket..... | 15 A |
| 9. Rear right door: power window, power window lock..... | 20 A |
| 10. Rear left door: power window, power window lock..... | 20 A |
| 11. Reserve | - |
| 12. Reserve | - |
| 13. Diesel filter heater | 15 A |
| 14. -..... | - |
| 15. Reserve | - |
| 16. Reserve | - |
| 17. Audio accessories..... | 5 A |
| 18. Reserve | - |
| 19. Foldable head restraint | 15 A |
| 20. Towing bracket wiring (15-feed) | 20 A |
| 21. Reserve | - |
| 22. -..... | - |
| 23. AWD | 7.5 A |
| 24. Four-C SUM..... | 15 A |
| 25. -..... | - |



Fuses

| | |
|--|------|
| 26. Parking assistance | 5 A |
| 27. Main fuse: Towing bracket wiring, Four-C, Parking assistance, AWD | 30 A |
| 28. Central locking system (PCL) | 15 A |
| 29. Trailer lighting, left: position lamps, direction indicator | 25 A |
| 30. Trailer lighting, right: brake lamp, rear fog lamp, direction indicator | 25 A |
| 31. Main fuse: Fuse 37, 38 | 40 A |
| 32. - | - |
| 33. - | - |
| 34. - | - |
| 35. - | - |
| 36. - | - |
| 37. Heated rear window | 20 A |
| 38. Heated rear window | 20 A |



[Empty rectangular box]

09

| | |
|---|-----|
| Overview HU-450 | 212 |
| Overview HU-650 | 213 |
| Overview HU-850 | 214 |
| Audio functions HU-450/650/850 | 215 |
| Audio functions HU-450 | 216 |
| Audio functions HU-650/850 | 217 |
| Radio functions HU-450/650/850 | 218 |
| Radio functions HU-450 | 219 |
| Radio functions HU-650/850 | 220 |
| Radio functions HU-450/650/850 | 221 |
| Cassette player HU-450 | 226 |
| CD player HU-650 | 227 |
| Internal CD changer HU-850 | 228 |
| External CD changer HU-450/650/850 (option) | 229 |
| Dolby Surround Pro Logic II HU-850 | 230 |
| Technical data | 231 |
| Phone functions (option) | 232 |
| Call options | 235 |
| Memory functions | 238 |
| Menu functions | 239 |
| Miscellaneous information | 244 |

INFOTAINMENT SYSTEM



10



10 Infotainment system

Overview HU-450

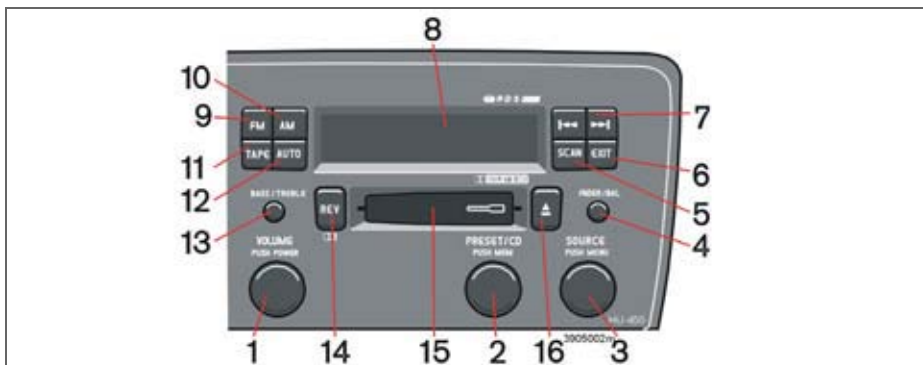

- 1. POWER (On/Off)** – Press
VOLUME – Turn
- 2. PRESET/CD PUSH MENU** –
Stored radio stations
CD changer (option)
- 3. SOURCE PUSH MENU** –
Opens main menu – Press
Turn to select:
Radio – FM, AM
Cassette
CD changer (option)
- 4. FADER** – Press out and turn
BAL – Press out, pull and turn
- 5. SCAN** – Automatic station search
- 6. EXIT** – Scroll back in the menu
- 7. Navigation buttons** –
CD/radio – seek/change station or
track
Cassette – Fast forward/rewind/select
next/previous track
- 8. Display**
- 9. FM** – Shortcut between FM1, FM2, FM3
- 10. AM** – Shortcut between AM1, AM2
- 11. TAPE** – Shortcut
- 12. AUTO** – Automatic station preset
- 13. BASS** – Press out and turn
TREBLE – Press out, pull and turn
- 14. REV** – Cassette – Direction select–
CD changer (option) – Random
- 15. Cassette opening**
- 16. Cassette eject**

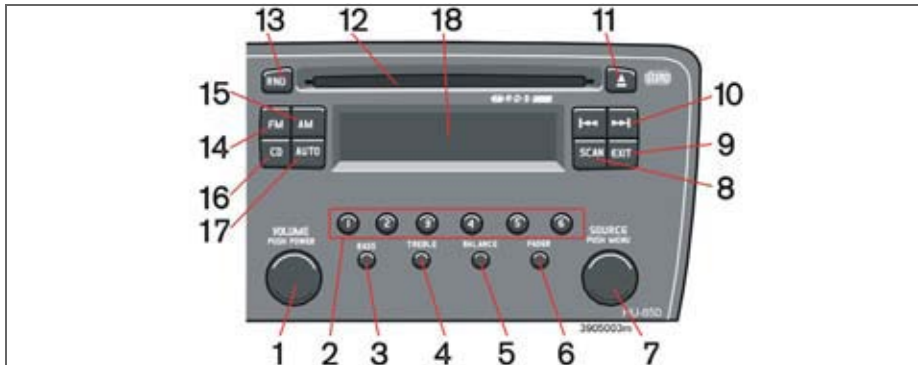

- | | | |
|---|---|--|
| 1. POWER (on/off) – Press | CD | 17. AUTO – Automatic station preset |
| VOLUME – Turn | CD changer (option) | 18. Display |
| 2. 1-6 – Station setting buttons/selecting CD changer position | 8. SCAN – Automatic station search | |
| 3. BASS – Press out and turn | 9. EXIT – Scroll back in the menu | |
| 4. TREBLE – Press out and turn | 10. Navigation buttons – seek/change station or track | |
| 5. BALANCE – Press out and turn | 11. CD eject | |
| 6. FADER – Press out and turn | 12. CD slot | |
| 7. SOURCE | 13. RND – CD random | |
| PUSH MENU – | 14. FM – Shortcut between FM1, FM2, FM3 | |
| Opens main menu – Press | 15. AM – Shortcut between AM1, AM2 | |
| Turn to select: | 16. CD – Shortcut | |
| Radio – FM, AM | | |



10 Infotainment system

Overview HU-850

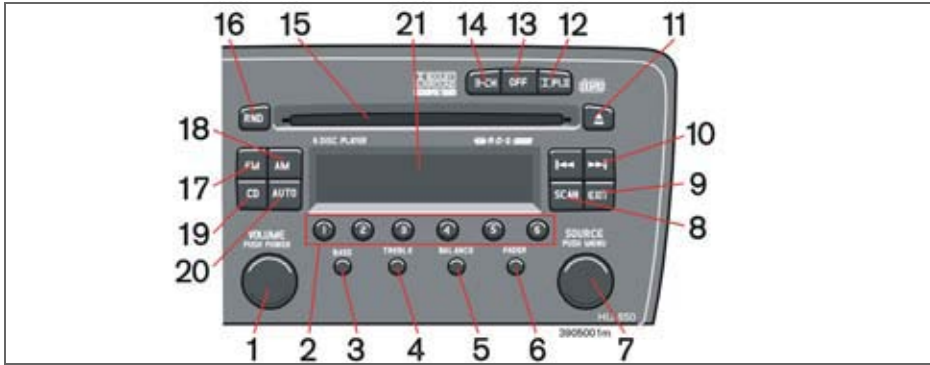

- | | | |
|--|--|--|
| <ul style="list-style-type: none"> 1. POWER (On/Off) – Press VOLUME – Turn 2. 1-6 – Station setting buttons/selecting CD changer position 3. BASS – Press out and turn 4. TREBLE – Press out and turn 5. BALANCE – Press out and turn 6. FADER – Press out and turn 7. SOURCE PUSH MENU– Opens main menu – Press Turn to select: Radio – FM, AM | <ul style="list-style-type: none"> CD CD changer (option) 8. SCAN – Automatic station search 9. EXIT – Scroll back in the menu 10. Navigation buttons – seek/change station or track 11. CD eject 12. Dolby Surround Pro Logic II 13. OFF – 2-channel stereo 14. 3-CH – 3-channel stereo 15. CD slot 16. RND – CD random | <ul style="list-style-type: none"> 17. FM – Shortcut between FM1, FM2, FM3 18. AM – Shortcut between AM1, AM2 19. CD – Shortcut 20. AUTO – Automatic station preset 21. Display |
|--|--|--|



Audio functions HU-450/650/850

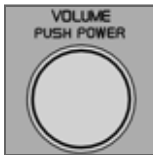

On/Off switch

Press the knob to turn on or switch off the radio.

Volume control

Turn the knob clockwise to increase volume. Volume control is electronic and lacks an end stop. If you have a steering wheel keypad, increase or decrease volume with (+) or (-) buttons.

Low battery voltage

If battery voltage is low, a text appears in the combined instrument unit display. The energy economy function of the car may switch off the radio. Charge the battery by starting the engine.

Volume control – TP/PTY/NEWS

If a cassette or CD is playing when the radio receives a traffic bulletin, news or selected programme type, the function is interrupted and the bulletin or message is broadcast with the volume selected for traffic information, news or programme type.

When the bulletin or message is finished, the unit immediately returns to the previously set volume and resumes playing the cassette or CD.

The audio system can be equipped with different options and different versions. There are three audio system versions:

- Performance
- High Performance
- Premium Sound.

FM and AM radio with RDS and CD player is however included in each version.

AUX

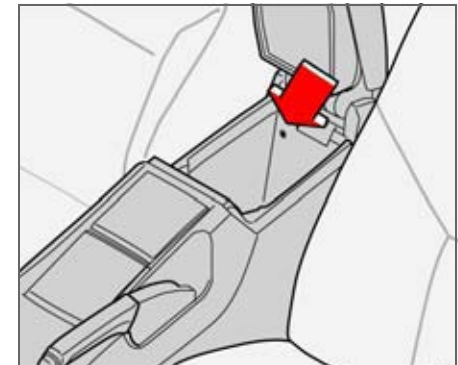

Input for external audio source (AUX) 3.5 mm

The AUX input can be used for connecting an MP3 player for example.

Sometimes the AUX external audio source can be heard at a different volume to the internal audio sources, e.g. the CD player. If the audio volume of the external audio source is too high then the sound quality may be impaired. Prevent this by adjusting the input volume of the AUX input.



Audio functions HU-450

Volume control – AUX

- Press **SOURCE**, turn to **ADVANCED MENU** and select by pressing **SOURCE**.
- Press **SOURCE**, turn to **AUDIO SETTINGS** and select by pressing **SOURCE**.
- Press **SOURCE**, turn to **AUX INPUT LEVEL** and select by pressing **SOURCE**.

In this mode the volume can be adjusted by turning **SOURCE**.

Optimum sound reproduction

The audio system is calibrated for optimum sound reproduction by means of digital signal processing.

This calibration takes into account loudspeakers, amplifiers, passenger compartment acoustics, listener position etc. for each combination of car model and audio system.

There is also a dynamic calibration that takes into account the level set for the volume control, radio reception and vehicle speed.

The controls explained in these operating instructions, e.g. Bass, Treble and Equalizer, are only intended for the user to be able to adapt the sound reproduction according to personal taste.

Bass



Adjust the bass by pressing out the knob and turning it to the left or right.

The bass is "normalised" in the centre position. Press the knob back into its original position after adjustment.

Treble



Adjust the treble by pressing the knob, pulling it out farther and turning it to the left or right. The treble is "normalised" in the centre position. Press the knob back into its original position after adjustment.

Fader – Balance front/rear



Set a suitable balance between the front and rear speakers by pressing the knob and turning it right (more sound from front pair) or left (more sound from rear pair). The balance is

"normalised" in the centre position. Press the knob back into its original position after adjustment.



Audio functions HU-650/850

Balance – right/left



Adjust balance by pressing and pulling out the knob and turning it left or right. The balance is "normalised" in the centre position. Press the knob back into its original position after

adjustment.

Selecting the sound source

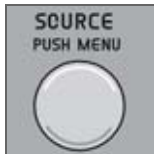

There are two ways to select sound source:

Either with the shortcut keys **AM**, **FM**, **TAPE** or with the **SOURCE** knob. Turn the **SOURCE** knob to select

between radio settings (FM1, FM2, FM3 and AM1, AM2). If a cassette player or CD changer (option) is connected, it can also be selected with the knob.



Press the **AM** and **FM** button repeatedly to toggle between FM1, FM2, FM3 and AM1, AM2.

The selected sound source is shown in the display.

Bass

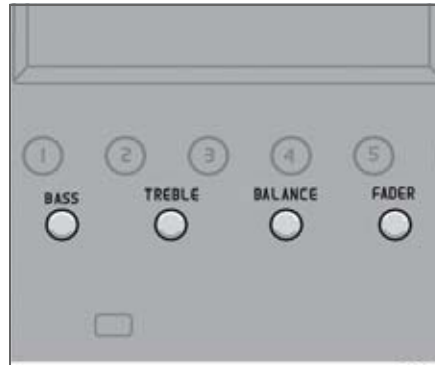

Adjust the bass by pressing out the knob and turning it to the left or right.

The bass is "normalised" in the centre position. Press the knob back into its original position after adjustment.

Treble

Adjust the treble by pressing the knob and turning it to the left or right. The treble is "normalised" in the centre position. Press the knob back into its original position after adjustment.

Balance – right/left

Adjust balance by pressing the knob and turning it left or right. The balance is "normalised" in the centre position. Press the knob back into its original position after adjustment.

Fader – Balance front/rear

Set a suitable balance between the front and rear speakers by pressing the knob and turning it right (more sound from front pair) or left (more sound from rear pair). The balance is "normalised" in the centre position. Press the knob back into its original position after adjustment.



Radio functions HU-450/650/850

Selecting the sound source



There are two ways to select sound source:

Either with the shortcut keys **AM**, **FM**, **TAPE** or with the **SOURCE** knob.

Turn the **SOURCE** knob to select between radio settings (FM1, FM2, FM3 and AM1, AM2). If a cassette player or CD changer (option) is connected, it can also be selected with the knob.



Press the **AM** and **FM** button repeatedly to toggle between FM1, FM2, FM3 and AM1, AM2.

The selected sound source is shown in the display.

Scanning

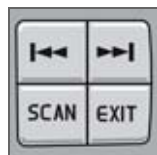

Press the **SCAN** button to start the search. When the radio finds a station, it stops there for about 10 seconds and then continues its search. To listen to the station, press the

SCAN or **EXIT** button.

Tuning

Press or to seek lower or higher frequencies. The radio searches for the next audible station and then stops. Press the button again to continue the search.

Manual tuning

Press and hold or . **MAN** is shown in the display. The radio slowly scrolls in the desired direction, increasing its tempo after a few seconds. Release the button when the desired frequency appears in the display.

The frequency can then be adjusted by briefly pressing one of the arrow keys or . Manual adjusting mode remains available for five seconds after the last press.

Steering wheel keypad



If you have a keypad in the steering wheel, press the right or left arrow to select preset stations.

NOTE

If the car is equipped with an integrated phone, the steering wheel keypad cannot be used for radio functions while the phone is in active mode. Phone information is continuously displayed while the phone is in active mode.

Switch off the phone by pressing . If there is no SIM card in the phone, switch it off, see page 212.



Programming stations

- Set the desired frequency.
- Briefly press the **PRESET/CD** knob.
- Select a number by turning forward or back.

Press again to store the desired frequency and station.

Preset



To select a preset radio programme, turn the **PRESET/CD** knob to the stored number. The preset programme is shown in the display.

Autostoring stations



This function automatically seeks and stores up to 10 strong AM or FM stations in a separate memory. The function is especially useful in areas in which you are unfamiliar with the radio stations or their frequencies.

- Select radio mode using the **FM** or **AM** button.

- Start the search by pressing and holding **AUTO** (more than 2 seconds).
- **AUTO** is shown in the display and a number of strong stations (max. 10) from the set frequency band are saved in the autostore memory. If there are no stations with sufficient signal strength, **NO STATION** is displayed.
- Briefly press the **AUTO** button or one of the arrows of the steering wheel keypad to scroll to another of the automatically preset stations.

AUTO is shown in the display when the radio is in Autostore mode. The text disappears when you return to normal Radio mode.

Returning to normal Radio mode

- Press **FM**, **AM** or **EXIT** or turn the **PRESET/CD** knob.

Returning to Autostore mode

- Briefly press **AUTO**.



Radio functions HU-650/850

Storing stations

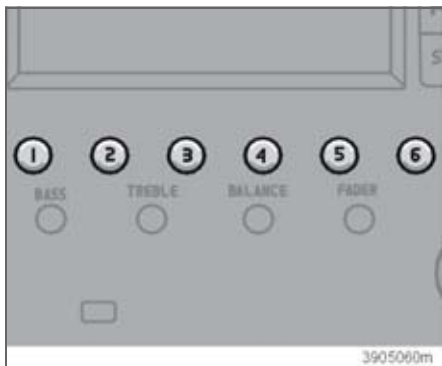

To store stations on the preset buttons 1-6:

- Set the desired station.
- Press and hold the desired station storage button.

The sound mutes a few seconds.

STATION STORED is shown in the display.

Up to 6 stations each can be stored under AM1, AM2, FM1, FM2 and FM3, a total of 30 stations.

Autostoring stations



AUTO seeks and stores up to ten strong AM or FM stations in a separate memory. If more than ten stations are found, the ten strongest are selected. This function is particularly useful

in areas in which you are unfamiliar with the radio stations and their frequencies.

- Select radio mode using the **AM** or **FM** button.

Start the search by pressing and holding **AUTO** (more than 2 seconds).

AUTO is shown in the display and a number of strong stations (max. 10) from the set frequency band are saved in the Autostore memory. If there are no stations with sufficient signal strength, then **NO STATION** is displayed.

- Briefly press the **AUTO** button or one of the arrows of the steering wheel keypad to scroll to another of the automatically preset stations.

AUTO is shown in the display when the radio is in Autostore mode. The text disappears when you return to normal Radio mode.

Returning to normal Radio mode

- Press the **FM**, **AM** or **EXIT** button.

Returning to Autostore mode

- Briefly press **AUTO**.



Radio functions HU-450/650/850

Radio Data System – RDS

RDS is a system that links together specific network transmitters. It is used, for example, to tune the correct frequency of a station irrespective of the transmitter or the active audio source (e.g. CD). The system can also be used for receiving traffic information and for finding broadcasts of a specific type. Radio text is also a component of RDS. A radio station can, for example, transmit information about the radio programme currently being broadcast.

Some radio stations do not use RDS or only use a limited range of its features.

PI seek (automatic search for stations)

When listening to an RDS transmitter, various information, such as traffic information, is stored in the radio.

When a preset RDS transmitter is later selected, the radio updates the transmitter's RDS information. If the radio is at the boundary or just outside of the transmitter's range, the radio automatically seeks the strongest possible transmitter of that channel.

If there is no audible transmitter, the radio quiets and the **PI SEEK** appears in the display until the station is found.

Traffic information – TP station

Traffic information from RDS stations interrupts other sound sources. The message is heard at the volume set for this specific feature. As soon as the message ends, the audio system returns to the previous sound source and volume setting.

Activating traffic information

- Select radio mode using the **FM** button and press **SOURCE**.
- Select **TP** and press **SOURCE**.
- Turn **SOURCE**, select **TP ON** (flashing text) and press **SOURCE**.
- Press **EXIT**.

Deactivate TP

- Select radio mode using the **FM** button and press **SOURCE**.
- Select **TP** and press **SOURCE**.
- Turn **SOURCE**, select **TP OFF** (flashing text) and press **SOURCE**.
- Press **EXIT**.

TP is shown in the display when this function is active.

Press **EXIT** if you do not wish to listen to a traffic bulletin. However, the TP function remains active and the radio waits for the next traffic bulletin.

Activate traffic information from a special channel

- Select radio mode using the **FM** button.
- Activate the station from which traffic information is to be received.
- Press **SOURCE**.
- Turn **SOURCE**, select **ADVANCED MENU** and press **SOURCE**.
- Turn **SOURCE**, select **RADIO SETTINGS** and press **SOURCE**.
- Turn **SOURCE**, select **TP STATION** and press **SOURCE**.
- Turn **SOURCE**, select **SET CURRENT** and press **SOURCE**.
- Press **EXIT**.

Deactivating TP Station

- Select radio mode using the **FM** button and press **SOURCE**.
- Turn **SOURCE**, select **ADVANCED MENU** and press **SOURCE**.
- Turn **SOURCE**, select **RADIO SETTINGS** and press **SOURCE**.
- Turn **SOURCE**, select **TP STATION** and press **SOURCE**.
- Turn **SOURCE**, select **TP STATION OFF** and press **SOURCE**.
- Press **EXIT**.



Radio functions HU-450/650/850

Alarm

"Alarm!" is shown in the radio display when an alarm message is broadcast. This function is used to warn motorists of major accidents and catastrophes, such as a bridge collapse or an accident at a nuclear plant.

TP search

This function allows you to listen to traffic information when travelling between different areas and countries without selecting a station.

- Select radio mode using the **FM** button and press **SOURCE**.
- Turn **SOURCE**, select **ADVANCED MENU** and press **SOURCE**.
- Turn **SOURCE**, select **RADIO SETTINGS** and press **SOURCE**.
- Turn **SOURCE**, select **TP SEARCH** and press **SOURCE**.
- Turn **SOURCE**, select **TP SEARCH ON** or **TP SEARCH OFF** (flashing text) and press **SOURCE**.
- Press **EXIT**.

News

Messages with a programme code (such as news from RDS stations) will interrupt other sound sources at the volume set for this specific feature. As soon as the news broadcast

is finished, the audio system returns to the previous sound source and volume setting.

Activating News

- Select radio mode using the **FM** button and press **SOURCE**.
- Turn **SOURCE**, select **NEWS** and press **SOURCE**.
- Turn **SOURCE**, select **NEWS ON** (flashing text) and press **SOURCE**.
- Press **EXIT**.

NEWS appears in the display.

Deactivating News

- Select radio mode using the **FM** button and press **SOURCE**.
- Turn **SOURCE**, select **NEWS** and press **SOURCE**.
- Turn **SOURCE**, select **NEWS OFF** (flashing text) and press **SOURCE**.
- Press **EXIT**.

NEWS disappears from the display.

Press **EXIT** if you do not wish to listen to a news broadcast. However, the **News** function remains active and the radio waits for the next news programme.

Interruptions for news from the current station

- Select radio mode using the **FM** button.
- Activate the station from which traffic information is to be received.
- Press **SOURCE**.
- Turn **SOURCE**, select **ADVANCED MENU** and press **SOURCE**.
- Turn **SOURCE**, select **RADIO SETTINGS** and press **SOURCE**.
- Turn **SOURCE**, select **NEWS STATION** and press **SOURCE**.
- Turn **SOURCE**, select **SET CURRENT** and press **SOURCE**.
- Press **EXIT**.

Deactivating News Station

- Select radio mode using the **FM** button and press **SOURCE**.
- Turn **SOURCE**, select **ADVANCED MENU** and press **SOURCE**.
- Turn **SOURCE**, select **RADIO SETTINGS** and press **SOURCE**.
- Turn **SOURCE**, select **NEWS STATION** and press **SOURCE**.
- Turn **SOURCE**, select **NEWS STN OFF** and press **SOURCE**.
- Press **EXIT**.



Radio functions HU-450/650/850

Programme type – PTY

Use the PTY function to select between the various programme types.

- Select radio mode using the **FM** button and press **SOURCE**.
- Turn **SOURCE**, select **PTY** and press **SOURCE**.
- Turn **SOURCE**, select **PTY** in the menu and press **SOURCE**.

The radio begins seeking the selected programme type.

If you do not wish to listen to the station found by the radio, continue the search using the left or right arrow key.

If the radio does not find a station with the selected programme type, it returns to the previous frequency.

Not all radio stations have a PTY designation.

| Programme type | Display shows |
|-------------------|---------------|
| OFF | PTY OFF |
| Current affairs | Current |
| Religion | Spiritual |
| Country music | Country |
| Documentary | Document |
| Finance | Finance |
| Folk music | Folk |
| Leisure and hobby | Leisure |

| Programme type | Display shows |
|--------------------|------------------|
| Children's progs | Children's progs |
| Oldies music | "Oldies" |
| Information | Info |
| Jazz music | Jazz |
| Serious classic | Classical |
| Culture and Art | Culture |
| Light classic | L Class |
| Easy listening | Easy list |
| National music | Nation M |
| News | News |
| Pop music | Pop |
| Travel and holiday | Travel |
| Rock music | Rock |
| Social affairs | Social |
| Sport | Sport |
| Drama | Drama |
| Phone In | Phone |
| Entertainment | Enterta |
| Education | Educ |
| Science | Science |
| Weather & Metro | Weather & Metro |
| Other music | Other M |

PTY standby

PTY mode is then in standby until the selected programme type is broadcast. When this happens, the radio automatically

switches to the station broadcasting the selected programme type.

Deactivating

- Select radio mode using the **FM** button and press **SOURCE**.
- Turn **SOURCE**, select **PTY** and press **SOURCE**.
- Turn **SOURCE**, select **PTY OFF** and press **SOURCE**.
- Press **EXIT**. The symbol **PTY** goes out and the radio returns to normal mode.

PTY language

Select the language for the radio display (English, German, French or Swedish).

- Select radio mode using the **FM** button and press **SOURCE**.
- Turn **SOURCE**, select **ADVANCED MENU** and press **SOURCE**.
- Turn **SOURCE**, select **RADIO SETTINGS** and press **SOURCE**.
- Turn **SOURCE**, select **PTY LANGUAGE** and press **SOURCE**.
- Turn **SOURCE**, select language and press **SOURCE**.
- Press **EXIT**.



Radio functions HU-450/650/850

Automatic frequency updating

The AF function is normally activate and ensures that the radio tunes to the strongest available transmitter.

Activating AF

- Select radio mode using the **FM** button and press **SOURCE**.
- Turn **SOURCE**, select **ADVANCED MENU** and press **SOURCE**.
- Turn **SOURCE**, select **RADIO SETTINGS MENU** and press **SOURCE**.
- Turn **SOURCE**, select **AF ON** (flashing text) and press **SOURCE**.
- Press **EXIT**.

Deactivating AF

- Select radio mode using the **FM** button and press **SOURCE**.
- Turn **SOURCE**, select **ADVANCED MENU** and press **SOURCE**.
- Turn **SOURCE**, select **RADIO SETTINGS MENU** and press **SOURCE**.
- Turn **SOURCE**, select **AF OFF** (flashing text) and press **SOURCE**.
- Press **EXIT**.

Regional radio programmes

The regional function is normally deactivated. When the function is activated you can continue to listen to a regional broadcasts even if the signal is weak.

Activating REG

- Select radio mode using the **FM** button and press **SOURCE**.
- Turn **SOURCE**, select **ADVANCED MENU** and press **SOURCE**.
- Turn **SOURCE**, select **RADIO SETTINGS MENU** and press **SOURCE**.
- Turn **SOURCE**, select **REG ON** (flashing text) and press **SOURCE**.
- Press **EXIT**.

Deactivating REG

- Select radio mode using the **FM** button and press **SOURCE**.
- Turn **SOURCE**, select **ADVANCED MENU** and press **SOURCE**.
- Turn **SOURCE**, select **RADIO SETTINGS MENU** and press **SOURCE**.
- Turn **SOURCE**, select **REG OFF** (flashing text) and press **SOURCE**.
- Press **EXIT**.

EON – Local/Distant (Enhanced Other Networks)

When EON is activated, the radio programme is interrupted for traffic bulletins, news broadcasts or the like from other channels.

The function has two levels

Local – only interrupts if the signal is strong.

Distant – also interrupts with weaker signals.

- Select radio mode using the **FM** button and press **SOURCE**.
- Turn **SOURCE**, select **ADVANCED MENU** and press **SOURCE**.
- Turn **SOURCE**, select **RADIO SETTINGS MENU** and press **SOURCE**.
- Turn **SOURCE**, select **EON** (flashing text) and press **SOURCE**.
- Turn **SOURCE**, select **Local** or **Distant** and press **SOURCE**.
- Press **EXIT**.

Resetting RDS functions

Resets all radio settings to the original factory settings.

- Select radio mode using the **FM** button and press **SOURCE**.
- Turn **SOURCE**, select **ADVANCED MENU** and press **SOURCE**.

**Radio functions HU-450/650/850**

- Turn **SOURCE**, select **RESET TO DEFAULT** and press **SOURCE**.
- Press **EXIT**.

ASC (Active Sound Control)

The ASC function automatically adapts the volume of the radio to vehicle speed.

Activating ASC:

- Select radio mode using the **FM** button and press **SOURCE**.
- Turn **SOURCE**, select **ADVANCED MENU** and press **SOURCE**.
- Turn **SOURCE**, select **AUDIO SETTINGS MENU** and press **SOURCE**.
- Turn **SOURCE**, select **ASC LEVEL** and press **SOURCE**.
- Turn **SOURCE** select **LOW**, **MEDIUM**, **HIGH** or **Off** and press **SOURCE**.

Radio text

Some RDS stations broadcast information, such as about programme content and artists.

Hold the **FM** button depressed a few seconds to access any transmitted radio text, which then appears in the display.

After the text is shown twice, the radio once again displays the station/frequency.

A brief press on **EXIT** ends the radio text display.



10 Infotainment system

Cassette player HU-450

Cassette opening

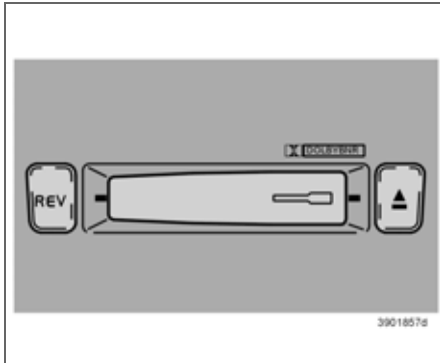

Insert the cassette in the slot with the wider part to the right. **TAPE Side A** appears in the display.

When one side is finished, the cassette player automatically plays back the other side (auto reverse).

To play a cassette that is already in the cassette player, turn the **SOURCE** knob or press the **TAPE** shortcut key.

Changing tape direction

Press the **REV** button in order to play the other side of the cassette; the side being played will be shown in the display.

Cassette eject



If you press the button, the tape stops and the cassette is ejected. Turn the **SOURCE** knob to select a new programme source. The cassette can be inserted or ejected even if the system is switched off.

Dolby B Noise Reduction

This is a preset function which can be switched off as follows: press and hold the **REV** button until the Dolby symbol disappears from the  display. Press the same button again in order to reactivate the Dolby function.

Dolby Noise Reduction is manufactured under license of Dolby Laboratories Licensing Corporation. Dolby and the double D symbol  are trademarks of Dolby Laboratories Licensing Corporation.

Scanning

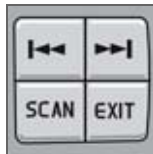



Scan plays the first ten seconds of each track.

Press the **SCAN** or **EXIT** button when you find a track you wish to listen to.

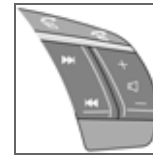
Fast forward/reverse



The tape is fast forwarded by pressing and holding  and is rewound with . "FF" (fast forward) or "REW" (rewind) is shown in the display during this time. Press the button again to

stop fast forwarding/rewinding.

Next track – Previous track

Pressing  automatically fast forwards the tape to the next track.

Pressing  automatically rewinds the tape to the previous track. For this function to be operational, there must be a five second pause between tracks.

If the car is equipped with a steering wheel keypad, the arrows can also be used.



CD player HU-650

CD player

Insert a CD. If there is already a CD in the player, activate it by turning the **SOURCE** knob or pressing the **CD** shortcut key.

CD eject

If you press the button shown in the illustration, the CD player stops playing and the disc is ejected.

NOTE

For reasons of traffic safety, you have twelve seconds to handle the ejected disc. Otherwise, the CD is drawn back into the player and resumes with the most recently played track.

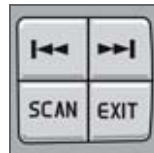
Fast forward/reverse and change track

Press and hold down the right or left-hand arrow key to fast forward/reverse a track or the whole disc. Fast forward/reversing cannot be done using the steering wheel keypad.

Briefly press the left or right-hand arrow key to go to the previous or next track. The steering wheel keypad can also be used for this. Track numbers are shown in the display.

Scanning

Scan plays the first ten seconds of each track.

Press the **SCAN** or **EXIT** button when you find a track you wish to listen to.

Random

Press **RND** (random) to connect the random function. The system plays tracks from the disc in random order. "RND" is displayed as long as this function is activated.

CD discs

Using CD discs burned at home could result in poor or non-existent sound. Music CD discs complying with the ISO 60908 standard provide the best sound quality.

IMPORTANT

Only use standard discs (12 cm in diameter). Do not use CDs with that have disc labels. The heat from the CD player could cause the label to come loose from the disc. The CD player could then be damaged.



10 Infotainment system

Internal CD changer HU-850

Internal CD changer

HU-850 contains an internal 6-disc CD changer. Press the **CD** shortcut key or turn the **SOURCE** knob to activate the CD player. The CD player resumes with the most recently played CD.

Up to 6 discs can be inserted in the CD player. An empty slot in the player must be selected when inserting a disc. This is done by selecting from buttons 1-6. An available position is shown in the display. Make sure "**LOAD DISC**" is shown before inserting a new disc.

CD eject



If you press the button shown in the illustration, the CD player stops playing and the disc is ejected.

NOTE

For reasons of traffic safety, you have twelve seconds to handle the ejected disc. Otherwise, the CD is drawn back into the player and resumes with the most recently played track.

Selecting disc number

Use buttons 1-6 to select which disc is to be played. The disc and track numbers are shown in the display.

Fast forward/reverse and change track

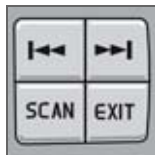

Press and hold down the right or left-hand arrow key to fast forward/reverse a track or the whole disc. Fast forward/reversing cannot be done using the steering wheel keypad.

Briefly press the left or right-hand arrow key to go to the previous or next track. The steering wheel keypad can also be used for this. Track numbers are shown in the display.

Scanning

Scan plays the first ten seconds of each track.

Press the **SCAN** or **EXIT** button when you find a track you wish to listen to.

Random



Press **RND** (random) to connect the random function. A randomly selected disc plays a randomly selected track. A new disc and track are then chosen the same way. "**RND**" is

displayed as long as this function is activated.

CD discs

Using CD discs burned at home could result in poor or non-existent sound. Music CD discs complying with the ISO 60908 standard provide the best sound quality.

IMPORTANT

Only use standard discs (12 cm in diameter). Do not use CDs with that have disc labels. The heat from the CD player could cause the label to come loose from the disc. The CD player could then be damaged.



External CD changer HU-450/650/850 (option)

CD changer

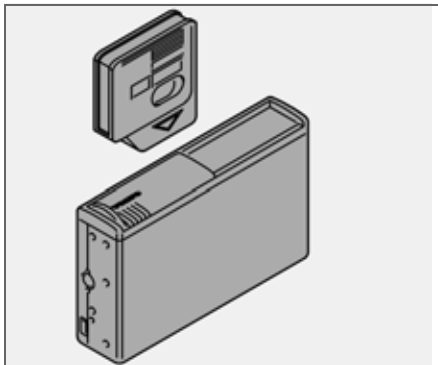

The external CD changer is mounted behind the panel on the rear left-hand side of the cargo area.

Activate the CD changer mode by turning the **SOURCE** knob; the CD changer resumes playing the most recently played disc and track. If the CD player cartridge* is empty, "**LOAD CARTRIDGE**" will be shown in the display.

Loading discs in the CD changer

- Slide open the CD changer cover
- Press the cartridge eject button on the changer.

- Pull out the CD cartridge and insert the discs.
- Reinsert the cartridge in the CD changer.

Selecting discs

Select which disc is to be played by turning the **PRESET/CD** knob (HU-450) or using buttons 1-6 (HU-650/850). The disc and track numbers are shown in the display.

Some CD changers take 10 discs. Press and hold button 6 for a couple of seconds to select discs 7-10.

Fast forward/reverse and change track

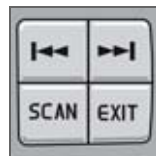

Press and hold down the right or left-hand arrow key to fast forward/reverse a track or the whole disc. Fast forward/reversing cannot be done using the steering wheel keypad.

Briefly press the left or right-hand arrow key to go to the previous or next track. The steering wheel keypad can also be used for this. Track numbers are shown in the display.

Scanning

Scan plays the first ten seconds of each track.

Press the **SCAN** or **EXIT** button when you find a track you wish to listen to.

Random

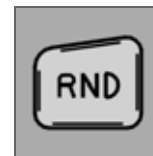

Press **RND** (HU-650 and 850) to activate the Random function. For radio HU-450, it is activated with the REV button.

A randomly selected track is played from a randomly selected disc. A new track or disc is then selected the same way. "RND" is displayed while this function is active.

CD discs

Using CD discs burned at home could result in poor or non-existent sound. Music CD discs complying with the ISO 60908 standard provide the best sound quality.



IMPORTANT

Only use standard discs (12 cm in diameter). Do not use CDs with that have disc labels. The heat from the CD player could cause the label to come loose from the disc. The CD player could then be damaged.



Dolby Surround Pro Logic II HU-850

General

Dolby Surround Pro Logic II is a further refinement of the previous system and provides a significantly improved sound experience. This improvement is especially noticeable to rear seat passengers.

Dolby Surround Pro Logic II together with a centre speaker in the instrument panel offers a sound experience very close to being there.

The normal left-right stereo channels are divided into left-centre-right. In addition, surround sound is produced by the rear speakers. Dolby Surround Pro Logic II works in CD mode.

3-channel stereo (3-CH) is recommended for AM and FM radio transmissions.

Dolby Surround Pro Logic II is a registered trademark of Dolby Laboratories Licensing Corporation. Dolby Pro Logic II Surround System is licensed from Dolby Laboratories Licensing Corporation.

Dolby Surround Pro Logic II Mode

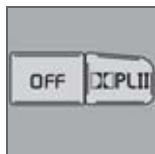

To select Dolby Surround Pro Logic II Mode, press "DOLBY PL II". "DOLBY PL II" is shown in the display. Press **OFF** to return to 2-channel stereo.

3-channel stereo

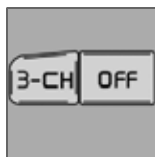

Select 3-channel stereo by pressing **3-CH**. "3 ch" will be shown in the display. Resume 2-channel stereo function by pressing **OFF**.

Centre Level

This function is used to set the level of the centre channel.

- Press **SOURCE**.
- Turn **SOURCE**, select **ADVANCED MENU** and press **SOURCE**.
- Turn **SOURCE**, select **AUDIO SETTINGS** and press **SOURCE**.
- Turn **SOURCE**, select **CENTRE LEVEL** and press **SOURCE**.
- Turn **SOURCE**, select level and press **SOURCE**.
- Press **EXIT**.

Surround Level

This function is used to set the output level of the rear channels.

- Press **SOURCE**.
- Turn **SOURCE**, select **ADVANCED MENU** and press **SOURCE**.
- Turn **SOURCE**, select **AUDIO SETTINGS** and press **SOURCE**.
- Turn **SOURCE**, select **SURROUND LEVEL** and press **SOURCE**.
- Turn **SOURCE**, select level and press **SOURCE**.
- Press **EXIT**.

Mid EQ Level

This function is used to fine-tune the sound from the speakers.

- Press **SOURCE**.
- Turn **SOURCE**, select **ADVANCED MENU** and press **SOURCE**.
- Turn **SOURCE**, select **AUDIO SETTINGS** and press **SOURCE**.
- Turn **SOURCE**, select **MID EQ LEVEL** and press **SOURCE**.
- Turn **SOURCE**, select level and press **SOURCE**.
- Press **EXIT**.



| |
|-----------------------|
| Technical data |
|-----------------------|

| | HU-450 | HU-650 | HU-850 |
|--------------------|-----------------------|-------------------------------|-----------------------------------|
| Output | 4 x 25 W | 4 x 25 W | 1 x 25 W (centre loudspeaker) |
| Impedance | 4 Ohm | | |
| Operating voltage | 12 V, negative ground | | |
| External amplifier | – | 4 x 50 W or 4 x 75 W (option) | 4 x 50 W or 4 x 75 W ¹ |
| Radio | | | |
| Frequency | | | |
| U (FM) | 87.5 – 108 MHz | | |
| M (AM) | 522 – 1611 kHz | | |
| L (AM) | 153 – 279 kHz | | |

¹HU-850 must be connected to an external amplifier.



10 Infotainment system

Phone functions (option)

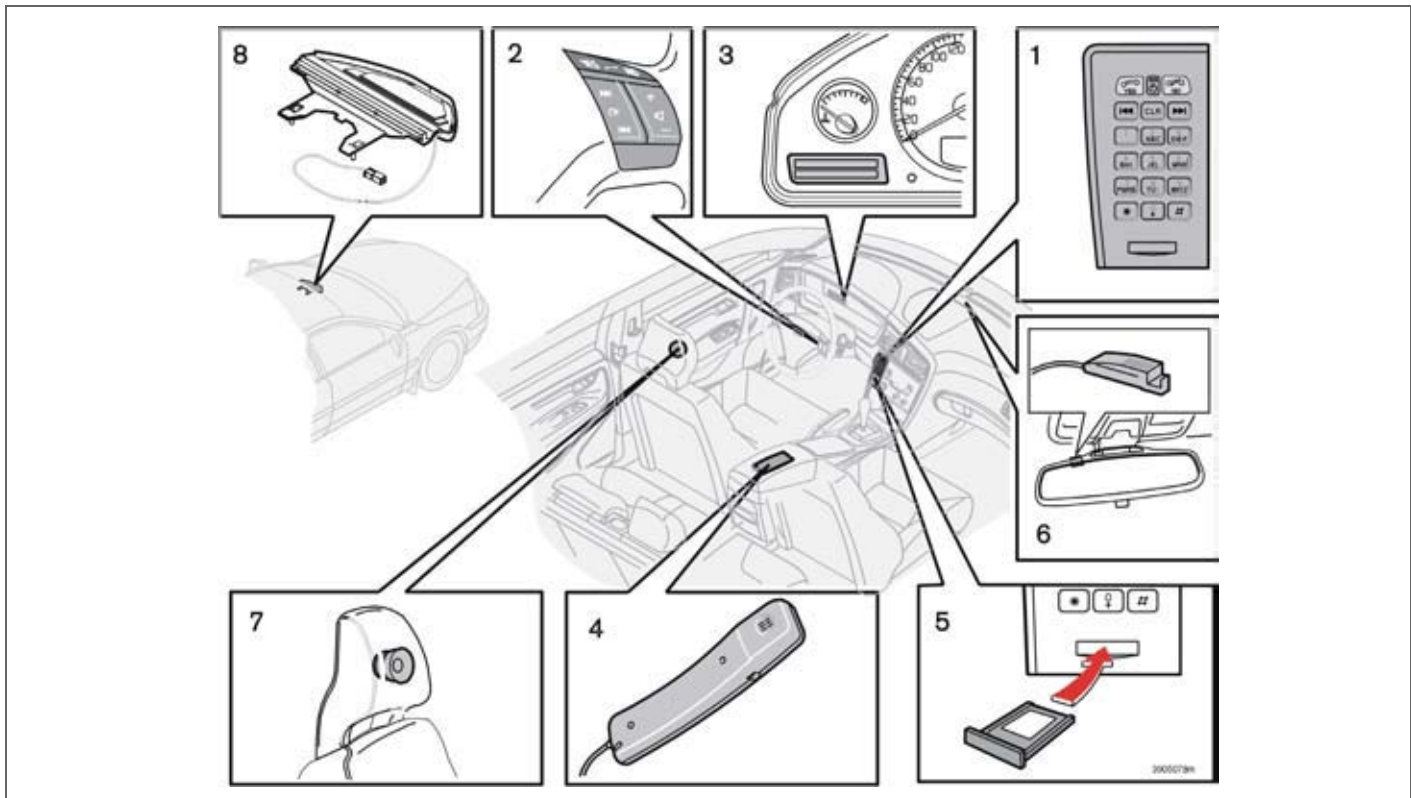

Phone system components



Phone functions (option)

General rules

- Put traffic safety first! If when driving you require to use the privacy handset in the armrest, park the car in a safe place first.
- Switch off the phone when refuelling.
- Switch off the phone in areas where blasting work is being carried out.
- Only allow authorised personnel service your phone.

Emergency calls

Emergency calls to emergency services can be made without the ignition key or the SIM card.

- Press the **On/Off** button.
- Ring the emergency number that applies to your region (within EU: 112).
- Press the green button .

Phone system components

1. Keypad on centre console

All phone functions can be controlled via the keypad in the centre console.

2. Steering wheel keypad

The majority of phone functions can be controlled via the steering wheel keypad.

When the phone is active, the keypad can only be used for phone functions. Phone information is always shown in the display when the phone is activated. The phone must be deactivated in order to use the buttons for radio settings, see page 234.

3. Display

The display will show menu functions, messages, phone numbers, etc.

4. Privacy handset

The privacy handset can be used for private conversations when you do not wish to be disturbed.

5. SIM card

The SIM card is inserted below the keypad in the centre console.

Switch off the phone whenever a SIM card is not in use. Otherwise, messages from other functions cannot be shown in the display.

6. Microphone

The microphone is integrated in the rearview mirror.

7. Loudspeaker

The speaker is integrated in the driver's seat head restraint.

8. Antenna

The antenna is mounted against the windscreen in front of the rearview mirror.



Phone functions (option)

SIM card

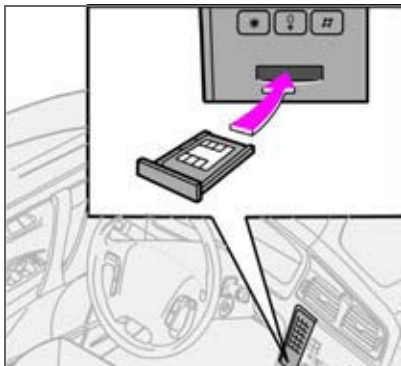

The phone can only be used with a valid SIM card (Subscriber Identity Module). Your network operator supplies this card.

Always use the SIM card during phone use; the name of your network operator will be displayed.

Switch off the phone whenever a SIM card is not in use. Otherwise, messages from other functions cannot be displayed and the radio controls in the steering wheel keypad cannot be used.

Switching the phone on and off



To switch the phone on

- Turn the ignition key to position I.
- Press the button marked in the illustration.

To switch the phone off

- Press the same button for three seconds.

If you switch off the car's ignition while the phone is switched on, it will be on the next time you switch on the ignition.

Phone calls cannot be received if the phone is switched off.

Active mode

The phone must be in active mode for its functions to be available for use (does not apply to receiving calls). Activate the phone by pressing  in the keypad in the centre console or in the steering wheel keypad.

Phone information is shown continuously in the display when the phone is activated.

Press  to deactivate the phone.



Call options

Display

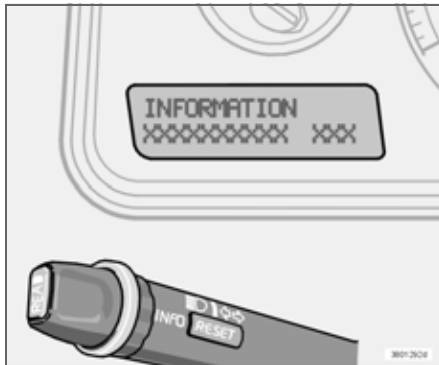

The display will show the function in use, for example menu selections, messages, phone numbers or settings.

Making and receiving calls

To dial

Dial the number and press on the steering wheel or centre console keypad (or lift the handset).

To receive an incoming call

Press (or lift the handset). You can also use Automatic Answer. See menu function 4.3.

The car audio system will be muted automatically while a phone conversation is in progress. Refer to menu function 5.6.5 on page 243 for information about audio system volume levels.

Ending a call

To end a call, press on one of the keypads or hang up the handset. The audio system resumes its previous mode.

Last dialled numbers

The phone automatically stores the last phone numbers/names called.

- Press on the steering wheel or centre console keypad.
- Use the arrows to scroll forward or backward through the last numbers dialled.
- Press (or lift the privacy handset) to make the call.

Privacy handset

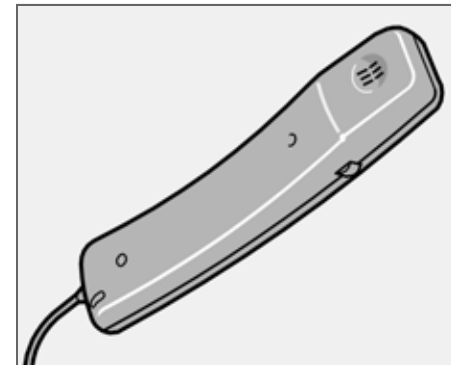

If you wish to talk undisturbed, use the privacy handset.

- Lift the handset.
- Dial the number on the centre console keypad.
- Press to dial.

Adjust the volume with the dial on the side of the handset. The call is ended when you replace the handset in its holder.

If you wish to switch to handsfree without ending the call

- Press and select **Handsfree**.
- Press and put the handset down, see page 235.



Call options

Speed dial

Storing speed dial numbers

A number stored in the phone book can be linked to a speed dial button (1-9) as follows:

- Scroll with to **Edit memory** (menu 3) and press .
- Scroll to **Speed dial** (Menu 3.4) and press .
- Choose the digit that is to be the speed dial number. Press to confirm.
- Find the desired name or phone number in the memory and press to select it.

Using speed dial

Press the desired speed dial button for about two seconds to make a call.



NOTE

Once you switch on the phone, wait a moment before using speed dial. If you wish to use a speed dial number, Menu 4.5 must be activated, see page 217.

Functions during a call

The following functions are available **during a call**:

- Scroll with the arrows and press **YES** to make a selection.

| Secret mode/ Secret mode off | Secret mode |
|---------------------------------|---|
| Hold/Don't hold | Choose whether or not the call is to be put on hold |
| Handset/Handsfree | Use the handset or handsfree |
| Memory | Show stored numbers |

The following functions are available when you have a **current call** and a **parked call**:

- Scroll with the arrows and press **YES** to make a selection.

| Secret mode/ Secret mode off | Secret mode |
|---------------------------------|--|
| Handset/Handsfree | Use the handset or handsfree |
| Memory | Show stored numbers |
| Three-way calling | Speak with both parties simultaneously (conference call) |
| Switch | Switch between the two calls |

The following functions are available when you have selected **Three-way calling** and have **two calls in progress**:



- Scroll with the arrows and press **YES** to make a selection.

| Secret mode/ Secret mode off | Secret mode |
|---------------------------------|------------------------------|
| Handset/Handsfree | Use the handset or handsfree |
| Memory | Show stored numbers |



Call waiting

If you hear a tone in the speaker when the phone is engaged followed by a two-tone signal, another party is placing a call to your phone. The two-tone signal will repeat until you answer the call or ringing ceases. When this occurs, you may accept or decline the call.

If you do not wish to take the call, press  or do nothing. If you do wish to take the call, press . Your current call will be put in "park mode". If you press , both calls will be terminated.

SMS

A single two-tone signal indicates that you have received an SMS message.

Volume

Raise the volume with the (+) button in the steering wheel keypad. Lower the volume with the (-) button.

When the phone is activated, the steering wheel keypad only controls the phone functions.

If you wish to adjust radio settings using these buttons you must first deactivate the phone, see page 234.



Memory functions

Storing in the memory

Phone numbers and names can be stored in either the phone memory or the SIM card memory.

When you accept a phone call from a party whose number is stored in the memory, their name will be shown in the display.

The phone memory can store up to 255 names.

Storing phone numbers with names

- Press and toggle to **Edit memory** (Menu 3). Press .
- Scroll to **Add** (Menu 3.1) and press .
- Enter a number and press .
- Enter a name and press .
- Choose in which memory to save with and press .

Enter a name (or message)

Press the button with the desired character: once for the first character, twice for the second, etc. Press 1 to enter a space.

| | |
|--|--|
| | space 1 - ? ! , . : ' () |
| | a b c 2 ä å à á â ã æ ç |
| | d e f 3 è é ê ë |
| | g h i 4 ì í î ï |
| | j k l 5 |
| | m n o 6 ñ ò ó ô õ |
| | p q r s 7 ß |
| | t u v 8 ü ú û ü |
| | w x y z 9 |
| | if you enter two letters in a row from the same button, press * between them or wait a few seconds |
| | + 0 @ * # & \$ £ / % |
| | change between upper and lower case letters |
| | delete the last letter or number entered. If you press for a long time, the enter number or text is deleted. |

Dialling from the memory





- Press in the centre console or in the steering wheel keypad.
- Choose from the following alternatives:
- Press in the centre console or in the steering wheel keypad and browse with the arrows until you locate the required name.
 - Press the key of the first letter in the name (or enter the name) and press .
 - Press to dial the selected number.

**Menu functions****General**

Use the menu function when checking functions, changing settings and programming new functions in your system. The various menu selections will be shown in the display.

Press  to access the menu function.

The following applies in the menu function:

- A long press on  means you exit the menu function.
- A short press on  means that you retract, cancel or reject an alternative.
- A press on  means that you confirm or select, or that you scroll from a submenu to the next submenu.
- The right arrow  leads to the next side menu.
- The left arrow  leads to the previous side menu.

Shortcuts

The menu options are numbered and can be selected directly using the number keys

and . The numbers are shown in the display together with the menu option.

Traffic safety

For reasons of safety, the menu system cannot be accessed at speeds in excess of 8 km/h. You may only complete activities in the menu system that have already been started.

The speed limiter can be disconnected using menu function 5.7.

Main menus/submenus**1. Call register**

- 1.1. Missed calls
- 1.2. Received calls
- 1.3. Dialed calls
- 1.4. Erase list
 - 1.4.1. All
 - 1.4.2. Missed
 - 1.4.3. Received
 - 1.4.4. Dialed
- 1.5. Call duration
 - 1.5.1. Last call
 - 1.5.2. Number of calls
 - 1.5.3. Total time
 - 1.5.4. Clear

2. Messages

- 2.1. Read
- 2.2. Write
- 2.3. Voice message
- 2.4. Settings
 - 2.4.1. SMSC number
 - 2.4.2. Validity
 - 2.4.3. Type



Menu functions

3. Edit memory

- 3.1. Enter item
- 3.2. Search
 - 3.2.1. Edit
 - 3.2.2. Erase
 - 3.2.3. Copy
 - 3.2.4. Move
- 3.3. Copy all
 - 3.3.1. SIM to phone
 - 3.3.2. Phone to SIM
- 3.4. Speed dial
- 3.5. Empty SIM
- 3.6. Empty memory
- 3.7. Status

4. Call options

- 4.1. Transmit number
- 4.2. Call waiting
- 4.3. Automatic answer
- 4.4. Automatic redial
- 4.5. Speed dial
- 4.6. Call divert service
 - 4.6.1. All calls
 - 4.6.2. When busy
 - 4.6.3. When not answered
 - 4.6.4. Not available
 - 4.6.5. Fax calls
 - 4.6.6. Data calls
 - 4.6.7. Cancel all diverts

5. Settings

- 5.1. Factory settings
- 5.2. Network selection
- 5.3. Language
 - 5.3.1. English UK
 - 5.3.2. English US
 - 5.3.3. Svenska
 - 5.3.4. Dansk
 - 5.3.5. Suomi
 - 5.3.6. Deutsch
 - 5.3.7. Nederlands
 - 5.3.8. Français FR
 - 5.3.9. Français CAN
 - 5.3.10. Italiano
 - 5.3.11. Español
 - 5.3.12. Português P
 - 5.3.13. Português BR
- 5.4. SIM security
 - 5.4.1. On
 - 5.4.2. Off
 - 5.4.3. AUTO
- 5.5. Change codes
 - 5.5.1. PIN code
 - 5.5.2. Phone code
- 5.6. Volume
 - 5.6.1. Ringer volume
 - 5.6.2. Ring signal
 - 5.6.3. Button click

- 5.6.4. Speed volume
- 5.6.5. Radio Auto Suppression
- 5.6.6. New SMS
- 5.7. Traffic safety



Menu functions

Menu options, description

1. Call register

1.1. Missed calls

A list of missed calls is shown here. You can choose to call, erase or store the number in the phone or SIM card memory for later use.

1.2. Received calls

A list of received calls is shown here. You can choose to call, erase or store the number in the phone or SIM card memory for later use.

1.3. Dialed calls

A list of dialed numbers is shown here. You can choose to call, erase or store the number in the phone or SIM card memory for later use.

1.4. Erase list

This option can be used to erase the list of menus 1.1, 1.2 and 1.3 as follows.

- 1.4.1. All
- 1.4.2. Missed
- 1.4.3. Received
- 1.4.4. Dialed

1.5. Call duration

Here you can see the duration of all your calls or the most recent. You can also see the number of calls and clear the call timer.

- 1.5.1. Last call

1.5.2. Number of calls

1.5.3. Total time

1.5.4. Clear

Resetting the call timer requires the phone code (see Menu 5.5).

2. Messages

2.1. Read

Here you can read received text messages. You can then choose to erase the message, forward it, change or save the entire message or parts of it.

2.2. Write

You can write a text message using the keypad. Then choose to save or send it.

2.3. Voice message

Listen to received messages.

2.4. Settings

Enter the number (SMSC number) of the message centre to which you want your messages transferred. Specify how the message is to reach the addressee and how long it is to be stored in the message centre.

2.4.1. SMSC number

2.4.2. Validity

2.4.3. Type

Contact your service provider for information on these settings and for an SMSC number.

3. Edit memory

3.1. Enter item

You can store names and phone numbers in the phone or SIM card memory. See the section on memory functions for more information.

3.2. Search

Changes in the memory can be made here.

3.2.1. Edit: Change data in the different memories.

3.2.2. Erase: Remove a saved name.

3.2.3. Copy: Copy a saved name.

3.2.4. Move: Transfer information between the memory of the phone and the SIM card.

3.3. Copy all:

Copy phone numbers and names from the SIM card to the phone memory.

3.3.1. From SIM to phone memory

3.3.2. From phone to SIM memory

3.4. Speed dial

A number stored in the phone book can be stored as a speed dial number.



Menu functions

3.5. Empty SIM

The entire memory of the SIM card can be erased.

3.6. Empty memory

The entire memory of the phone can be erased.

3.7. Status

See how many places in the SIM card or phone memory are occupied by names and numbers.

4. Call options

4.1. Transmit number

Select whether or not your own number should be displayed to the person you call. Contact your network operator regarding permanently withheld numbers.

4.2. Call waiting

Choose whether or not you want to be alerted during a phone call that there is another call coming in.

4.3. Automatic answer

Chose to answer without using the keypad.

4.4. Automatic redial

Choose to call a previously dialled number that was busy.

4.5. Speed dial

Here you set whether or not speed dial is to be active. The function must be activated if you wish to dial using speed dial numbers.

4.6. Diversions

Here you can choose when and what type of calls are to be diverted to a specified phone number.

- 4.6.1. All calls (this setting only applies during the call in progress).
- 4.6.2. When busy
- 4.6.3. When not answered
- 4.6.4. Not available
- 4.6.5. Fax calls
- 4.6.6. Data calls
- 4.6.7. Cancel all diverts

5. Settings

5.1. Factory settings

Function to return to the system's factory settings.

5.2. Network selection

Choose a network automatically or manually.

- 5.2.1. AUTO
- 5.2.2. Manual

5.3. Language

Here you can choose which language the phone is to display.

- 5.3.1. English UK
- 5.3.2. English US
- 5.3.3. Svenska
- 5.3.4. Dansk
- 5.3.5. Suomi
- 5.3.6. Deutsch
- 5.3.7. Nederlands
- 5.3.8. Français FR
- 5.3.9. Français CAN
- 5.3.10. Italiano
- 5.3.11. Español
- 5.3.12. Português P
- 5.3.13. Português BR

5.4. SIM security

Choose if the PIN code is to be on, off, or automatic.

- 5.4.1. On
- 5.4.2. Off
- 5.4.3. AUTO

5.5. Change codes

Change the PIN code or phone code.

- 5.5.1. PIN code

**Menu functions**

- 5.5.2. Phone code (use 1234 until you change to your own code). The phone code is used to reset the call timer.

i NOTE

Make a note of your code as save it in a safe place.

5.6. Volume

- 5.6.1. Ringer volume: Here you can choose the volume of the ringer for incoming calls.
- 5.6.2. Ring signal: You have eight different types of ring signals to choose from.
- 5.6.3. Button click: On or Off.
- 5.6.4. Speed volume: Choose whether the volume should be adjusted according to speed.
- 5.6.5. Radio Auto Suppression: Here you choose whether or not the volume of the radio should remain the same during phone calls.
- 5.6.6. New SMS: Select whether or not you wish the phone

to notify of new SMS messages with an audible signal.

5.7. Traffic safety

Here you can choose to disengage the speed limiter for the menu system, i.e. choose to use the menu system even while driving.



Miscellaneous information

Radio/Phone

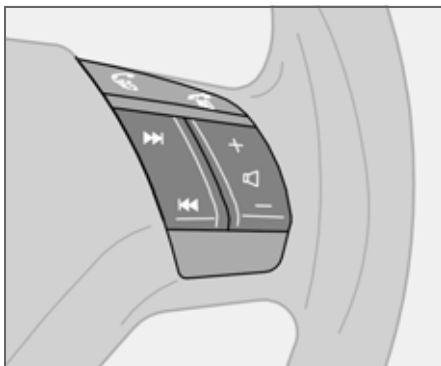

The four lower buttons on the steering wheel keypad are common to the audio system and phone.

The phone must be in active mode in order to adjust the phone functions with these buttons, see page 234.

If you wish to adjust radio settings using these buttons you must first deactivate the phone.

- Press .

Double SIM cards¹

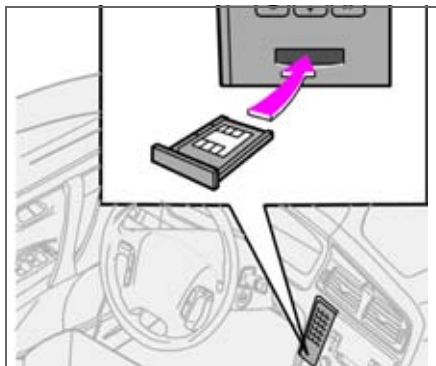

Many network operators offer double SIM cards - one for your car and one for another phone. A double SIM card allows you to have the same number for two different phones.

Ask your network operator about the options available and the use of double SIM cards.

Specifications

| | |
|-----------------------------|------------------|
| Output | 2 W |
| SIM card | Small |
| Memory entries | 255 ¹ |
| SMS (Short Message Service) | Yes |
| Data/Fax | No |
| Dualband | Yes (900/1800) |

¹The phone memory contains 255 positions. The number of SIM card memory positions varies depending on your subscription.

IMEI number

To block the phone, you must provide your network operator with the phone's IMEI number. This is a 15-digit serial number that is programmed in the phone.

- Dial *#06# to show this number in the display.

Make a note of this number and keep it in a safe place.

¹Certain markets



| | |
|------------------------------|-----|
| Type designation | 248 |
| Dimensions and weights | 249 |
| Engine specifications | 251 |
| Engine oil | 253 |
| Fluids and lubricants | 256 |
| Fuel | 257 |
| Catalytic converter | 260 |
| Electrical system | 261 |

01 10

SPECIFICATIONS



11

11 Specifications

Type designation

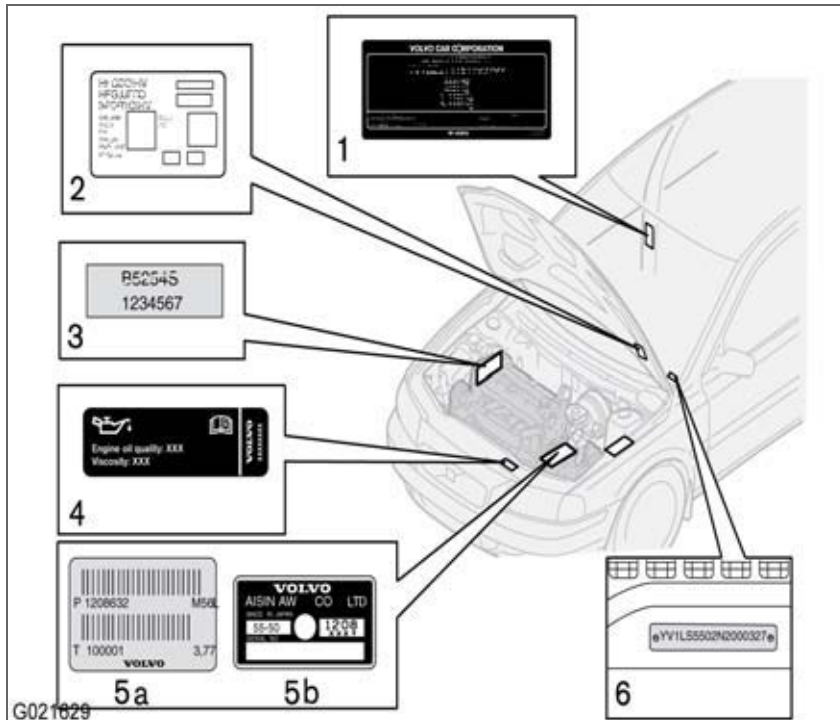

Knowing the car's type designation, vehicle identification and engine numbers can facilitate all contact with a Volvo dealer regarding the car and when ordering spare parts and accessories.

1. Type designation, vehicle identification number, maximum permissible weights, codes for colour and upholstery and type approval number.
2. Decal for parking heater.
3. Engine type designation, component and serial number.
4. The engine oil decal (certain engine variants) specifies oil grade and viscosity.
5. Gearbox type designation and serial number.
 - a: Manual gearbox.
 - b: Automatic gearbox AW.
6. VIN number (type and model year designation plus chassis number).

Further information on the car is presented in the registration document.

G021629

Dimensions and weights

Dimensions

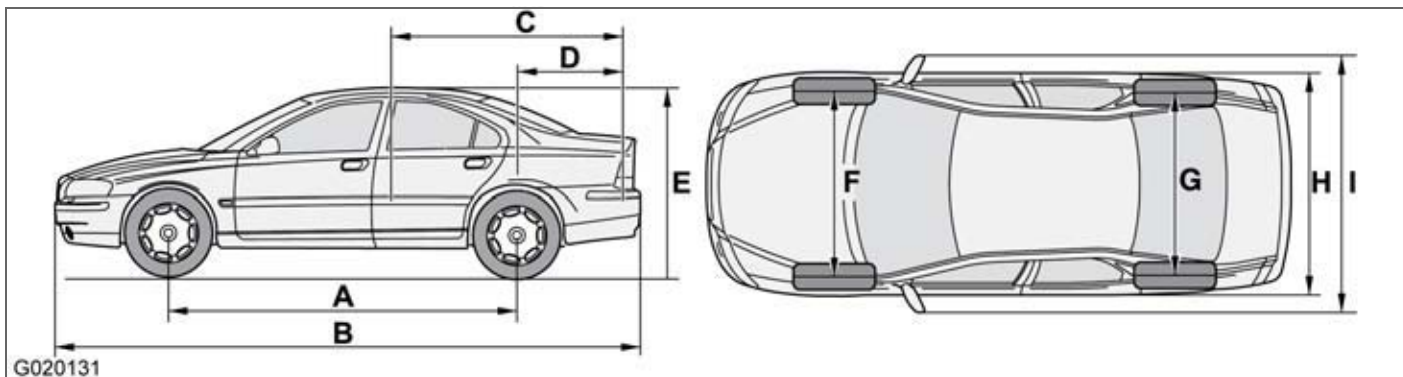

| Position in illustration | Dimensions | mm |
|--------------------------|---------------------------------|------|
| A | Wheelbase | 2715 |
| B | Length | 4603 |
| C | Load length, floor, folded seat | 1661 |
| D | Load length, floor | 824 |
| E | Height | 1428 |
| F | Front track | 1561 |
| G | Rear track | 1542 |
| H | Width | 1804 |
| I | Width including door mirrors | 2071 |

Dimensions and weights

Weights

Kerb weight includes the driver, the weight of the fuel tank when filled to 90 % and various fluids, such as washer fluid and coolant etc.

The weight of passengers and accessories, such as a towbar, load carriers, space box etc. and towball load (when a trailer is hitched, see table), influences the payload and must not be included in the kerb weight.

Permitted weight (in addition to driver) =
Gross vehicle weight – Kerb weight.



WARNING

The car's driving characteristics change depending on how heavily it is loaded and how the load is distributed.

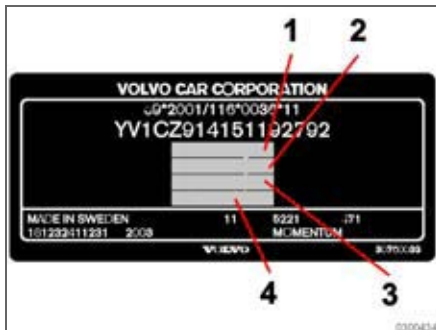

1. Max. total weight
2. Max. train weight (car+trailer)
3. Max. front axle load
4. Max. rear axle load

Maximum load: See registration document.

Maximum roof load: 100 kg

Trailer with brakes

| Maximum trailer weight (kg) | Maximum towball load (kg) |
|-----------------------------|---------------------------|
| 0-1200 | 50 |
| 1201-1600 | 75 |

Trailer without brakes

| Maximum trailer weight kg | Maximum towball load kg |
|---------------------------|-------------------------|
| 750 | 50 |

Engine specifications

| | 2.4 | BIFUEL (CNG) | 2.4 | 2.0T | 2.5T | 2.4T |
|---------------------------------|----------|--------------|----------|---------------|---------------|-----------------------|
| Engine designation ¹ | B5244S2 | B5244SG | B5244S | B5204T5 | B5254T2 | B52 44T4 ² |
| Output (kW/rpm) | 103/4500 | 103/5800 | 125/6000 | 132/5500 | 154/5000 | 162/5500 |
| (hp/rpm) | 140/4500 | 140/5800 | 170/6000 | 180/5500 | 210/5000 | 220/5500 |
| Torque (Nm/rpm) | 220/3300 | 192/4500 | 225/4500 | 240/2600-5000 | 320/1500-4500 | 350/2100-4000 |
| No. of cylinders | 5 | 5 | 5 | 5 | 5 | 5 |
| Bore (mm) | 83 | 83 | 83 | 81 | 83 | 81 |
| Stroke (mm) | 90 | 90 | 90 | 77 | 93.2 | 93.2 |
| Swept volume (litres) | 2.44 | 2.44 | 2.44 | 1.98 | 2.52 | 2.4 |
| Compression ratio | 10.3:1 | 10.3:1 | 10.3:1 | 9.5:1 | 9.0:1 | 8.5:1 |

¹Engine type designation, component and serial number can be read on the engine, see page 248.

²Thailand, Malaysia

Engine specifications

| | T5 | D | 2.4D | D5 |
|---------------------------------|---------------|---------------|---------------|---------------|
| Engine designation ¹ | B5244T5 | D5244T7 | D5244T5 | D5244T4 |
| Output (kW/rpm) | 191/5500 | 92/4000 | 120/5500 | 136/4000 |
| (hp/rpm) | 260/5500 | 126/4000 | 163/5500 | 185/4000 |
| Torque (Nm/rpm) | 350/2100-5000 | 300/1750-2250 | 340/1750-2750 | 400/2000-2750 |
| No. of cylinders | 5 | 5 | 5 | 5 |
| Bore (mm) | 81 | 81 | 81 | 81 |
| Stroke (mm) | 93.2 | 93.2 | 93.2 | 93.2 |
| Swept volume (litres) | 2.40 | 2.40 | 2.40 | 2.40 |
| Compression ratio | 8.5:1 | 17.0:1 | 17.0:1 | 17.0:1 |

¹Engine type designation, component and serial number can be read on the engine, see page 248.

Engine oil

Adverse driving conditions

Check the oil level more frequently for long journeys:

- towing a caravan or trailer.
- in mountainous regions.
- at high speeds.
- in temperatures colder than $-30\text{ }^{\circ}\text{C}$ or hotter than $+40\text{ }^{\circ}\text{C}$.

This can produce abnormally high oil temperature or oil consumption.

Also check the oil level more often if the car is often driven short distances (less than 10 km) when temperatures are low (below $+5\text{ }^{\circ}\text{C}$).

Choose a fully synthetic engine oil for adverse driving conditions. It provides extra protection for the engine.

Volvo recommends Castrol oil products.

**IMPORTANT**

In order to fulfil the requirements for the engine's service intervals all engines are filled with a specially adapted synthetic engine oil at the factory. The choice of oil has been made very carefully with regard to service life, starting characteristics, fuel consumption and environmental impact.

An approved engine oil must be used in order that the recommended service intervals can be applied. Only use a prescribed grade of oil (see the engine compartment decal) for both filling and oil change, otherwise you will risk affecting service life, starting characteristics, fuel consumption and environmental impact.

Volvo Car Corporation disclaims all warranty liability if engine oil of the prescribed grade and viscosity is not used.

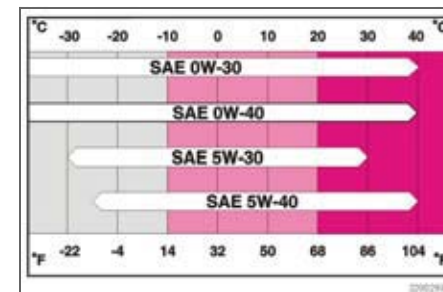
Viscosity chart

11 Specifications

Engine oil

Oil decal



When the oil decal shown alongside here is in the car's engine compartment, the following applies. See location on page 248.

Oil grade: ACEA A3/B3/B4

Viscosity: SAE 0W-30

When driving under adverse conditions, use ACEA A5/B5 SAE 0W-30.

| Engine variant | | Volume between MIN-MAX (litres) | Volume ¹ (litres) |
|----------------|---------|---------------------------------|------------------------------|
| Bi-fuel | B5244SG | 1.2 | 5.8 |

¹Including filter change.

Engine oil

Oil decal



When the oil decal shown alongside here is in the car's engine compartment, the following applies. See location on page 248.

Oil grade: ACEA A5/B5

Viscosity: SAE 0W-30

| Engine variant | | Volume between MIN-MAX (litres) | Volume ¹ (litres) |
|----------------|----------------------|---------------------------------|------------------------------|
| 2.0T | B5204T5 | 1.2 | 5.5 |
| 2.4 | B5244S | | |
| | B5244S2 | | |
| 2.4T | B5244T4 ² | | |
| T5 | B5244T5 | | |
| 2.5T | B5254T2 | | |
| D5 | D5244T4 | 2.0 | 6.2 |
| 2.4D | D5244T5 | | |
| D | D5244T7 | | |

¹ Including filter change.

² Thailand, Malaysia

11 Specifications

Fluids and lubricants

| Fluid | System | Volume (litres) | Recommended oil grade |
|-------------------------------|--------------------------------------|-----------------|---|
| Gearbox oil | Manual 5 speed (M56/M58) | 2.1 | Transmission fluid MTF 97309 |
| | Manual 6-speed (M66) | 2.0 | |
| | Automatic gearbox (AW55-50, AW55-51) | 7.2 | Transmission fluid JWS 3309 |
| | Automatic gearbox (TF-80SC) | 7.0 | |
| Coolant | Petrol engine without turbo | 8.0 | Coolant with corrosion inhibitor mixed with water, see packaging. The thermostat starts opening at: 90 °C in petrol engines and at 82 °C in diesel engines. |
| | Petrol engine with turbo | 9.0 | |
| | Diesel | 12.5 | |
| Air conditioning ¹ | | | Oil: PAG Refrigerant R134a (HFC134a) |
| Brake fluid | | 0.6 | DOT 4+ |
| Power steering | System: of which reservoir | 0.9 | Power steering fluid: WSS M2C204-A or equivalent product. |
| | | 0.2 | |
| Washer fluid | without high-pressure washing | 4.5 | Use a washer antifreeze recommended by Volvo, mixed with water for temperatures below freezing. |
| | with high-pressure washing | 6.4 | |

¹ Weights can vary depending on the engine variant. Contact an authorised Volvo workshop for the exact information.

IMPORTANT

The recommended transmission fluid must be used to prevent damage to the gearbox. Do not mix with any other transmission fluid. If the transmission is topped up with a different fluid, contact an authorised Volvo workshop for servicing.

NOTE

Under normal driving conditions the gearbox oil does not need changing during its service life. However, it may be necessary under adverse driving conditions, see page 253.

Fuel

Consumption, emissions and volume

| Engine | | Gearbox | Consumption litre/100 km | Emissions of CO ₂ (g/km) | Tank volume (litres) |
|---------|----------------------|-----------------------------|-----------------------------|--|-------------------------|
| 2.4 | B5244S2 | Manual 5 speed (M56) | 8.8 | 209 | 70 |
| | | Automatic gearbox (AW55-51) | 9.5 | 226 | |
| Bi-fuel | B5244SG | Manual 5 speed (M56) | 8.7 | 208 | 30 |
| | | Automatic gearbox (AW55-50) | 9.5 | 228 | |
| 2.4 | B5244S | Manual 5 speed (M56) | 8.9 | 212 | 70 |
| | | Automatic gearbox (AW55-51) | 9.5 | 226 | |
| 2.0T | B5204T5 | Manual 5 speed (M56) | 8.9 | 212 | 70 |
| | | Automatic gearbox (AW55-51) | 9.5 | 227 | |
| 2.5T | B5254T2 | Manual 5 speed (M56) | 9.1 | 217 | 70 |
| | | Automatic gearbox (AW55-51) | 9.8 | 234 | |
| | AWD | Manual 5-speed (M58) | 9.7 | 232 | 72 |
| | | Automatic gearbox (AW55-51) | 10.2 | 244 | |
| 2.4T | B5244T4 ¹ | – | – | 70 | |
| T5 | B5244T5 | Manual 6-speed (M66) | 9.3 | 220 | 70 |
| | | Automatic gearbox (AW55-51) | 9.8 | 234 | |

¹ Certain countries

11 Specifications

Fuel

| Engine | | Gearbox | Consumption litre/100 km | Emissions of CO2 (g/km) | Tank volume (litres) |
|--------|---------|-----------------------------|-----------------------------|----------------------------|-------------------------|
| D5 | D5244T4 | Automatic gearbox (TF-80SC) | 7.5 | 199 | 70 |
| | | Manual 6-speed (M66) | 6.6 | 174 | |
| 2.4D | D5244T5 | Automatic gearbox (TF-80SC) | 7.5 | 199 | |
| | | Manual 6-speed (M66) | 6.6 | 174 | |
| | | Manual 5 speed (M56) | 6.4 | 169 | |
| D | D5244T7 | Manual 5 speed (M56) | 6.4 | 169 | |

Fuel consumption and emissions of carbon dioxide

Official fuel consumption figures are based on a standard driving cycle in accordance with EU Directive 80/1268 comb. Fuel consumption figures may change if the car is equipped with extra equipment that affects the car's weight. The manner in which the car is driven and other non-technical factors can also affect fuel consumption. Consumption is higher and power output lower for fuel with an octane rating of 91 RON.

NOTE

Extreme weather conditions, towing a trailer or driving at high altitudes in combination with fuel grade are factors that could affect the car's performance.

Petrol

Most engines can be run with octane ratings of 91, 95 and 98 RON.

- 91 RON must not be used for 4-cylinder engines and should only be used in exceptional cases with other engines.
- 95 RON can be used for normal driving.
- 98 RON is recommended for optimum performance and minimum fuel consumption.

When driving in temperatures above +38 °C, it is recommended to use fuel with the highest possible octane rating for optimum performance and fuel economy.

Petrol – Norm EN 228

IMPORTANT

Use only unleaded petrol to avoid damaging the catalytic converter. In order for the Volvo warranty to apply, never mix alcohol with petrol, the fuel system could be damaged.

Diesel

The diesel engine's fuel system is sensitive to contaminants. Only use diesel from well-known oil companies, see page 185.

Diesel – Norm EN 590 or JIS K2204

Catalytic converter

General

The purpose of the catalytic converter is to purify exhaust gases. It is located in the flow of exhaust gases close to the engine so that it quickly reaches operating temperature. The catalytic converter consists of a monolith (ceramic or metal) with channels. The channel walls are lined with a thin layer of platinum, rhodium and palladium. These metals act as catalysts, i.e. they participate in and accelerate a chemical reaction without being used up themselves.

Lambda-sond™ oxygen sensor

The Lambda-sond is part of a control system intended to reduce emissions and improve fuel economy.

An oxygen sensor monitors the oxygen content of the exhaust gases leaving the engine. This value is fed into an electronic system that continuously controls the injection valves. The ratio of air to fuel is continuously adjusted. These adjustments create optimal conditions for efficient combustion, and together with the three-way catalytic converter reduce harmful emissions (hydrocarbons, carbon monoxide and nitrous oxides).

General

12 V system with a voltage-regulated alternator. Single pole system in which the chassis and engine block are used as conductors.

Battery

| Voltage | 12 V | 12 V | 12 V |
|---------------------------|---------|--------------------|--------------------|
| Cold start capacity (CCA) | 590 A | 600 A ¹ | 700 A ² |
| Reserve capacity (RC) | 100 min | 120 min | 135 min |
| Capacity (Ah) | 60 | 70 | 80 |

¹ Cars equipped with High Performance audio system.

² Cars equipped with diesel, keyless drive, audio system Premium Sound, fuel-driven heater or RTI.

If the battery is changed, replace it with a battery of the same cold start capacity and reserve capacity as the original (see the decal on the battery).

Electrical system

Bulbs

| Lighting | Output W | Socket |
|---|----------|-----------|
| Dipped beam | 55 | H7 |
| Bi-Xenon | 35 | D2S |
| Main beam | 55 | HB3 |
| Brake lights, reversing lamps, rear fog lamp | 21 | BA15s |
| Direction indicators, rear/front (yellow) | 21 | BAU15s |
| Rear position/parking lamps, rear side marker lamps | 5 | BAY15d |
| Courtesy lighting, cargo area lighting, number plate lighting | 5 | SV8.5 |
| Vanity mirror | 1.2 | SV5.5 |
| Front position/parking lamps, front side marker lamps | 5 | W2.1x9.5d |
| Direction indicators in door mirrors (yellow) | 5 | W2.1x9.5d |
| Fog lamps | 55 | H11 |
| Glovebox lighting | 3 | BA9 |



A

- ABS 122
 - ABS fault 42
 - AC 72, 75
 - Active Bi-Xenon Lights, ABL 48
 - Active chassis 46
 - Active chassis –FOUR-C 126
 - Active Yaw Control 124
 - Adaptive system 117
 - Additional heater 79
 - Air conditioning 72, 75
 - ECC 74
 - general 70
 - Air distribution 77
 - ECC 75
 - Air distribution, A/C 73
 - Airbag
 - driver's and front passenger side 15
 - Alarm
 - arming 104
 - automatic alarm activation 104
 - deactivating a triggered alarm 104
 - disarming 104
 - general 104
 - indicator lamp 105
 - Alarm detectors 47
 - All-wheel drive 121
 - Audio functions
 - HU-450/650/850 215
 - Audio HU-450, overview 212
 - Audio HU-850, overview 214
 - AUTO CLIMATE 74
 - Automatic car wash 174
 - Automatic dimming 61
 - Automatic gearbox 117
 - safety systems 117
 - towing and recovery 129
 - trailer 132
 - W button 119
 - Automatic locking 99
 - Auxiliary lamps 47
 - Average fuel consumption 52
 - AWD 121
- ## B
- Backrest rear seat, tipping 91
 - Battery
 - care 191
 - jump starting 131
 - overload 111
 - replacement 192
 - replacing the battery in the remote control 98
 - symbols on the battery 191
 - Blind spot (BLIS) 149
 - BLIS 46, 149
 - Bonnet 184
 - Booster cushion
 - lowering 31
 - raising 30
 - Booster cushion, integrated 30
 - Boot lid
 - automatic locking 99
 - driving with open boot lid 110
 - locking/unlocking 96
 - Bottle holder for rear seat passengers 89
 - Brake fluid, checking and topping up 189
 - Brake system 122, 189
 - Brakes, handbrake 56
 - Bulb holder
 - location of the bulbs 199
 - number plate lighting 198
 - removal 199
 - Bulbs
 - replacement 193
 - specifications 262
- ## C
- Car care, leather upholstery 176
 - Car upholstery 176
 - Car wash 174
 - Cargo area
 - bag holder 92
 - loading 141
 - locking 47

| | | | | | |
|---|-----|--|---------|---|-----|
| Cassette player, HU-450 | 226 | Coat hanger | 89 | Display, messages | 45 |
| Catalytic converter | 260 | Collision | | Door mirrors | 64 |
| recovery | 129 | collision sensors | 22 | defrosting | 64 |
| CD changer, external | 229 | inflatable curtain | 22 | Driveable punctured tyres | 164 |
| CD player, HU-650 | 227 | Collision, see Collision | 22 | Driver's door control panel | 58 |
| Checks | | Colour code, paint | 177 | Driving | |
| fluids and oils | 186 | Combined instrument panel | 40 | adverse driving conditions | 186 |
| Child | | Compass | 61 | cooling system | 111 |
| child seats and airbags | 26 | calibration | 63 | economical | 110 |
| Children | | setting the zone | 62 | in water | 110 |
| child safety locks | 103 | Condensation | 185 | slippery driving conditions | 110 |
| child seats and side airbags | 20 | Coolant, checking and topping up | 188 | with open boot lid | 110 |
| location in car, table | 29 | Coolant, filling | 188 | with trailer | 132 |
| safety | 30 | Cooling system | 111 | DSTC, see also stabiliser system | 46 |
| safety equipment | 26 | Cruise control | 55 | symbol | 44 |
| Cigarette lighter | 46 | D | | DSTC, see also Stability control system ... | 124 |
| Cigarette lighter socket, rear seat | 57 | <hr/> | | DSTC, see also Stability system | |
| Clean inside and out | 8 | Deadlocks | 47, 101 | deactivating/activating | 124 |
| Cleaning | | temporary deactivation | 102 | symbol | 44 |
| automatic car wash | 174 | Defroster | 73 | <hr/> | |
| car wash | 174 | rear window | 73 | ECC, electronic climate control | 70 |
| seatbelts | 176 | Defroster, door mirrors | 73 | ECO pressure | |
| upholstery | 176 | Designation of dimensions | 156 | fuel economy | 159 |
| water-repellent surface | 175 | Diesel | 185 | table | 160 |
| Climate control settings | | Diesel filter | 185 | Economical driving | 110 |
| AUTO | 74 | Diesel particle filter | 114 | Electrical socket | |
| Climate control, general | 70 | Dipped beam | 49 | centre console | 46 |
| Clock, setting | 41 | Direction indicators | 51 | rear seat | 57 |
| Clutch fluid, checking and topping up | 189 | | | | |

- Electronic immobiliser96
- Emergency puncture repair 167
- Emissions257
- carbon dioxide259
- Emissions system, fault indicator43
- Engine184
- Engine compartment184
- Engine oil186
- adverse driving conditions253
 - capacities254
 - changing186
 - filter186
 - oil grade253
 - oil pressure43
- Engine specifications251
- Expectant mothers, safety13
-
- F**
-
- Fan
- AC73
 - ECC75
- Floor mats82
- Fluids and oils
- checks186
- Fluids, capacities256
- FOUR-C –Active chassis126
- Front seats, heated48
- Fuel
- consumption257
 - fuel consumption, display52
 - fuel economy159
 - fuel filter185
 - fuel system185
 - parking heater79
 - refuelling112
- Fuel filler flap, emergency opening113
- Fuel gauge40
- Functions during a call236
- Fuses
- box in cargo area207
 - box in engine compartment202
 - box in passenger compartment .. 204, 205
 - changing201
 - general201
-
- G**
-
- Gearbox
- automatic117
 - manual116
- Glovebox89
- locking101
- Gross vehicle weight250
-
- H**
-
- Handbrake43, 56
- Head restraint
- centre seat, rear91
- Head restraints
- lowering47
- Headlamp pattern143
- Headlamps194
- headlamp washers54
 - off/on49
- Heating
- front seats73, 75
- Home safe lighting51
- HU-450, overview212
- HU-850, overview214
-
- I**
-
- Ignition keys115
- IMEI number244
- Immobiliser96, 115
- "Important!" texts6
- Indicator lamp105
- Instrument lighting49
- Instrument overview
- left-hand drive car36
 - right-hand drive car38
- Integrated booster cushion30
- Interior lighting84
- Interior rearview mirror61
- Intermittent wiping53
- ISOFIX, fixture system32

J

| | |
|---------------------|-----|
| Jack | 161 |
| Jump starting | 131 |

K

| | |
|------------------------------------|-----|
| Kerb weight | 250 |
| Key | 96 |
| remote control | 96 |
| Kick-down, automatic gearbox | 120 |

L

| | |
|--|-----|
| Lambda-sond | 260 |
| Leather upholstery, washing instructions | 176 |
| Levelling | 133 |
| Lighting | |

| | |
|---------------------------------------|-----|
| Active Bi-Xenon Lights | 48 |
| automatic lighting | 84 |
| automatic lighting, dipped beam | 49 |
| bulb replacement, general | 193 |
| bulbs, specifications | 262 |
| dipped beam | 49 |
| exterior | 49 |
| headlamp levelling | 49 |
| home safe lighting | 51 |
| in the passenger compartment | 84 |
| lighting panel | 49 |
| main/dipped beam | 51 |
| position/parking lamps | 49 |
| reading lamps | 84 |

| | |
|------------------------------------|----|
| rear fog lamp | 50 |
| switching headlamp pattern | |
| right/left-hand traffic, ABL | 48 |

Lighting, bulb replacement

| | |
|--|-----|
| cargo area | 197 |
| courtesy lighting | 200 |
| dipped beam | 194 |
| direction indicators | 196 |
| fog lamp | 197 |
| front | 193 |
| location of the bulbs in the bulb holder | 199 |
| main beam | 195 |
| parking lamps | 195 |
| position lamps | 195 |
| rear lamp | 199 |
| side marker lamps | 197 |
| vanity mirror lighting | 200 |

Loading

| | |
|---------------------|-----|
| general | 141 |
| load capacity | 141 |

Locking

| | |
|--------------------|-----|
| from inside | 100 |
| from outside | 99 |
| unlocking | 99 |

Lock-up function

| | |
|-------|-----|
| | 117 |
|-------|-----|

Lubricants, capacities

| | |
|-------|-----|
| | 256 |
|-------|-----|

M

| | |
|------------------------------|----|
| Main beam | 51 |
| off/on | 49 |
| switching and flashing | 51 |

| | |
|-------------------------|----|
| Main beam "flash" | 51 |
|-------------------------|----|

| | |
|---------------------------------|-----|
| Maintenance, rustproofing | 178 |
|---------------------------------|-----|

| | |
|----------------------|-----|
| Manual gearbox | 116 |
|----------------------|-----|

Misting

| | |
|--|--------|
| attending to the windows | 70 |
| rear window | 73 |
| removing with defroster function | 73, 75 |
| timer function, ECC | 76 |

N

| | |
|--------------------|---|
| "Note" texts | 6 |
|--------------------|---|

O

| | |
|---|----|
| Oil pressure, see also Engine oil | 43 |
|---|----|

| | |
|---------------------------------|--------|
| Outside temperature gauge | 40, 41 |
|---------------------------------|--------|

| | |
|-----------------------|-----|
| Oxyhydrogen gas | 131 |
|-----------------------|-----|

P

| | |
|-------------|----|
| PACOS | 18 |
|-------------|----|

Paint

| | |
|--|-----|
| paintwork damage and touching up | 177 |
|--|-----|

Paintwork

| | |
|-------------------|-----|
| colour code | 177 |
|-------------------|-----|

| | |
|-------------------|----|
| Panel vents | 71 |
|-------------------|----|

| | |
|--------------------------|---------|
| Parking assistance | 47, 127 |
|--------------------------|---------|

| | |
|--------------------------------------|-----|
| sensors for parking assistance | 128 |
|--------------------------------------|-----|

| | |
|---------------------|--------|
| Parking brake | 43, 56 |
|---------------------|--------|

Parking heater

| | |
|------------------------|----|
| battery and fuel | 79 |
|------------------------|----|

| | | | | | |
|------------------------------------|-----|--|----------|---|---------|
| general | 78 | Rearview mirrors | 61 | Seatbelt | 12 |
| parking on a hill | 78 | defrosting | 48 | pregnancy | 13 |
| time setting | 79 | door | 47, 64 | seatbelt tensioner | 14 |
| Parking lamps | 49 | interior | 61 | Seatbelt reminder | 13 |
| Petrol grade | 259 | Recirculation | | Seatbelt tensioner | 14 |
| Phone system | 232 | A/C | 73 | Seats | |
| PI seek | 221 | ECC | 76 | manual setting | 82 |
| Pinch protection, sunroof | 66 | Recommended child seats, table | 29 | Service locking | 101 |
| Polishing | 175 | Recovery | 129 | Service programme | 182 |
| Position lamps | 49 | Refrigerant | 70 | Side airbags | 20 |
| Power seat | 83 | Refuelling | | SIM card | 234 |
| Power steering | 115 | fuel cap | 112 | SIM cards, double | 244 |
| Power steering fluid, checking and | | refuelling | 112 | SIPS bags | 20 |
| topping up | 189 | Relay/fuse box | | Soot filter | 45, 114 |
| Power windows | 58 | in cargo area | 207 | SOOT FILTER FULL | 114 |
| blocking | 59 | in engine compartment | 202 | Spare wheel | 161 |
| passenger seat | 59 | in passenger compartment | 204, 205 | Temporary spare | 162 |
| rear seat | 60 | Remote control | 96 | Speed classes, tyres | 156 |
| Privacy handset | 235 | functions | 96 | Speed dial | 236 |
| | | replacing the battery | 98 | Speed related power steering | 115 |
| R | | Remote control functions | 97 | Speedometer | 40 |
| Radio functions | | Reverse gear inhibitor, five-speed | 116 | Spin Control | 124 |
| general | 218 | Rustproofing | 178 | SRS system | |
| HU-450 | 219 | S | | general | 16 |
| HU-650/850 | 220 | Safety | 12 | SST –Self Supporting run flat Tyres | 164 |
| Rain sensor | 53 | safety systems, table | 25 | Stability control system | 124 |
| Reading lamps | 84 | Seat | | Stains | 176 |
| Rear window, defrosting | 48 | power seat | 83 | | |

Standby mode, phone234

Starting from cold, automatic gearbox 117

Starting the engine 114

STC124

Steering lock 115

Steering wheel

- cruise control55
- keypad left-hand side55
- steering wheel adjustment56

Stone chips and scratches 177

Storage compartment86

Storage spaces in the passenger compartment86, 87

Storing radio stations219

Sunroof65

- pinch protection66
- sunscreen66

Sunscreen, sunroof66

Symbols125

- warning symbols42

T

Tachometer40

Tank volume257

Temperature

- actual temperature70
- passenger compartment, electronic
- climate control74

- passenger compartment, manual climate control 72

Tools 161

Towbar, see Towing equipment 134

Towing 129

Towing equipment

- general 134
- installation 136
- removing 139
- specifications 135

Towing eye 129

TPMS –Tyre Pressure Monitoring System 163

Traction control 124

Traction control system 124

Trailer

- cable 134
- driving with a trailer 132
- trailer weight 250

Trip computer 52

Trip meter 40

Tuning, radio 218

Type designation 248

Tyre

- pressure 159

Tyres

- designation of dimensions 156
- direction of rotation 158
- driving characteristics 156

ECO pressure 160

- general 156
- puncture repair 167
- speed classes 156
- summer and winter wheels 158
- tread wear indicators 157
- tyre pressure monitoring 163
- winter tyres 157

U

Unlocking

- from inside 100
- from outside 99
- keyless 99

V

Vehicle data 182

Ventilation 71

Volume, phone237

W

Warning lamp

- Stability and traction control system ... 124

Warning symbol, AIRBAG system 14

"Warning!" texts 6

Warning triangle 161

Washer fluid, topping up 188

Washers

- for headlamps54
- for windscreen54

| | |
|-------------------------------------|-----|
| Washing the car | 174 |
| Waxing | 175 |
| Wheels | |
| fitting | 166 |
| removing | 165 |
| Whiplash injury WHIPS | 23 |
| WHIPS | 23 |
| child seat/booster cushion | 23 |
| Windscreen wipers | |
| rain sensor | 53 |
| washers | 54 |
| Windscreen wipers and washers | 53 |
| Winter driving | 114 |
| Winter tyres | 157 |
| Wiper blades | |
| replacing, windscreen | 190 |

Volvo. for life

VOLVO

Volvo Car Corporation TP 9489 (English), AT 0720 Printed in Sweden, Göteborg 2007, Copyright © 2000-2007 Volvo Car Corporation